

Abbreviations

The following abbreviations may be used in this manual. They stand for;

Assy	Assembly
R	Right (Right side viewed from rear side)
L	Left (Left side viewed from rear side)
IN	Intake side/Inside
EX	Exhaust side/Exterior side
STD	Standard
OP	Optional
OS	Oversized
L (100L)	Number of links (100 links)
C2	Countershaft 2nd gear (Number indicates the stage of gear)
M5	Mainshaft 5th gear (Number indicates the stage of gear)
rpm	Revolutions per minute
BTDC	Before Top Dead Center
ATDC	After Top Dead Center
BBDC	Before Bottom Dead Center
ABDC	After Bottom Dead Center
AC	Alternating current
DC	Direct current
CDI	Capacitive discharge ignition
4P	Number of connector pins

The following letters or marks stamped on parts indicates the installation direction.

IN	Install with "IN" toward inside/exhaust side.
TOP	Install with "TOP" toward up. (Do not install with the letter upside down.)
UP	Install with the "UP" toward up. (Do not install with the letter upside down.)
UP Δ	Install with the triangular mark facing/pointing up. (Some parts might be stamped with an arrow.)
F \leftarrow	Install with the arrow toward front. (Some parts might be stamped with a triangular mark.)
R (RH)	Install on the right side, viewed from rear side. If an arrow or triangular mark is stamped, install with the mark toward right.
L (LH)	Install on the left side, viewed from rear side. If an arrow or triangular mark is stamped, install with the mark toward left.
F (FR)	Indicates the front side of the vehicle.
R (RR)	Indicates the rear side of the vehicle.
OUT (OUTSIDE)	...	Install with the letter toward out.
LOWER	Indicates lower level.
UPPER (FULL)	Indicates upper level.
\leftarrow	Indicates the rotating direction, if stamped on a rotating part.

If a punch mark (+) is stamped on a part, it indicates the installation direction or an alignment point. Pay attention to the mark when assembling.

1. GENERAL INFORMATION

1

GENERAL SAFETY	1-1	FASTENERS	1-6
SERVICE RULES	1-3	BALL BEARING REPLACEMENT	1-16

GENERAL SAFETY

Carbon Monoxide

If the engine must be running to do some work, make sure the area is well ventilated. Never run the engine in an enclosed area.

▲ WARNING

- The exhaust contains poisonous carbon monoxide gas that can cause loss of consciousness and may lead to death.

Run the engine only in an open area or with an exhaust evacuation system in an enclosed area.

Gasoline

Work in a well ventilated area. Keep cigarettes, flames or sparks away from the work area or where gasoline is stored.

▲ WARNING

- Gasoline is extremely flammable and is explosive under certain conditions. **KEEP OUT OF REACH OF CHILDREN.**

Battery Hydrogen Gas & Electrolyte

▲ WARNING

- The battery gives off explosive gases; keep sparks, flames and cigarettes away. Provide adequate ventilation when charging.
- The battery contains sulfuric acid (electrolyte). Contact with skin or eyes may cause severe burns. Wear protective clothing and a face shield.
 - If electrolyte gets on your skin, flush with water.
 - If electrolyte gets in your eyes, flush with water for at least 15 minutes and call a physician.
- Electrolyte is poisonous.
 - If swallowed, drink large quantities of water or milk and follow with milk of magnesia or vegetable oil and call a physician. **KEEP OUT OF REACH OF CHILDREN.**

Coolant

Under some conditions, the ethylene glycol in engine coolant is combustible and its flame is not visible. If the ethylene glycol does ignite, you will not see any flame, but you can be burned.

▲ WARNING

- Avoid spilling engine coolant on the exhaust system or engine parts. They may be hot enough to cause the coolant to ignite and burn without a visible flame.
- Coolant (ethylene glycol) can cause some skin irritation and is poisonous if swallowed. **KEEP OUT OF REACH OF CHILDREN.**
- Do not remove the radiator cap when the engine is hot. The coolant is under pressure and could scald you.
- Keep hands and clothing away from the cooling fan, as it starts automatically.

If coolant contacts your skin, wash the affected areas immediately with soap and water. If coolant contacts your eyes, flush them thoroughly with fresh water and get immediate medical attention. If coolant is swallowed, the victim must be forced to vomit then rinse mouth and throat with fresh water before obtaining medical attention. Because of these dangers, always store coolant in a safe place, away from the reach of children.

Brake Fluid

CAUTION

- Spilling fluid on painted, plastic or rubber parts will damage them. Place a clean shop towel over these parts whenever the system is serviced. **KEEP OUT OF REACH OF CHILDREN.**

Brake Dust

Never use an air hose or dry brush to clean brake assemblies. Use an OSHA-approved vacuum cleaner or alternate method approved by OSHA, designed to minimize the hazard caused by airborne asbestos fibers.

▲ WARNING

- Inhaled asbestos fibers have been found to cause respiratory disease and cancer.

GENERAL INFORMATION

Nitrogen Pressure

For shock absorbers with a gas-filled reservoir:

⚠ WARNING

- Use only nitrogen to pressurize the shock absorber. The use of an unstable gas can cause a fire or explosion resulting in serious injury.
- The shock absorber contains nitrogen under high pressure. Allowing fire or heat near the shock absorber could lead to an explosion that could result in serious injury.
- Failure to release the pressure from a shock absorber before disposing of it may lead to a possible explosion and serious injury if it is heated or pierced.

To prevent the possibility of an explosion, release the nitrogen by pressing the valve core. Then remove the valve stem from the shock absorber reservoir. Dispose of the oil in a manner acceptable to the Environment Protection Agency (EPA).

Before disposal of the shock absorber, release the nitrogen by pressing the valve core. Then remove the valve stem from the shock absorber.

Hot Components

⚠ WARNING

- Engine and exhaust system parts become very hot and remain hot for some time after the engine is run. Wear insulated gloves or wait until the engine and exhaust system have cooled before handling these parts.

Used Engine/Transmission Oil

⚠ WARNING

- Used engine oil (or transmission oil in two-strokes) may cause skin cancer if repeatedly left in contact with the skin for prolonged periods. Although this is unlikely unless you handle used oil on a daily basis, it is still advisable to thoroughly wash your hands with soap and water as soon as possible after handling used oil. **KEEP OUT OF REACH OF CHILDREN.**

SERVICE RULES

Use **only metric tools** when servicing this motorcycle, scooter, ATV or pilot. Metric bolts, nuts and screws are not interchangeable with English fasteners. The use of incorrect tools and fasteners may damage the motorcycle, or scooter, ATV or pilot.

Special tools are designed to remove or replace a specific part or assemblies without damage. The use of other procedures, without using the specified special tools, may damage the parts.

Clean the outside of a part or assembly before removing it from the motorcycle or opening its cover for service. Dirt that has accumulated on the outside could fall into the engine, chassis or brake system and cause damage later.

Clean the parts after disassembly but before measuring them for wear. Parts should be washed in high-flash point solvent and dried with compressed air. Beware of parts containing O-rings or oil seals since these are adversely affected by most cleaning solvents.



Control cables must not be bent or distorted. This will lead to stiff operation and premature cable failure.

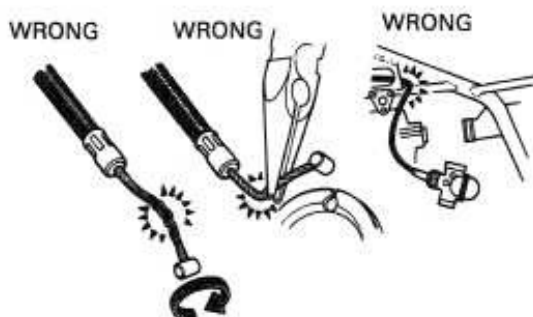

Rubber parts can deteriorate with age and are highly-susceptible to damage from solvents and oils. Check these parts before reassembly and replace as necessary.

Loosening a part with multiple fasteners should be done from the outside-to-inside in a crisscross pattern, loosening the small fasteners first. Loosening the big fasteners first will place an excessive force on the smaller fasteners.

Complex assemblies, such as transmission parts, should be stored in the proper assembly order and held securely with wire. This will simplify reassembly later.

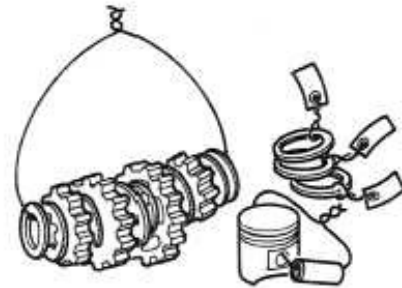

Reassembly position of critical parts should be noted before the parts are disassembled. This will allow those dimensions (depth, distance, or position) to be correctly duplicated upon reassembly.

Non-reuseable parts are always replaced whenever something is disassembled. These include the gaskets, metal sealing washers, O-rings, oil seals, snap rings, and cotter pins.



CAUTION

- Coolant or brake fluid will damage the appearance of painted parts. In addition, these fluids can damage the structural integrity of plastic or rubber parts.

GENERAL INFORMATION

Ball bearings are removed using tools which apply force against one or both (inner and outer) bearing races. If the force is applied against only one race (either inner or outer), the bearing will be damaged during removal and must be replaced. If the force is applied against both races equally, the bearing will not be damaged during removal.

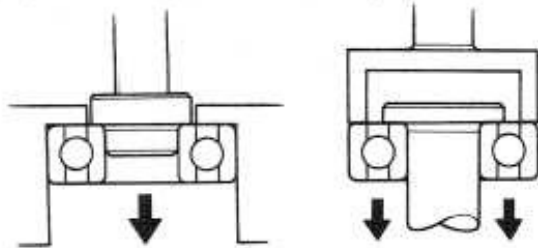

Both examples ruin the bearing

Ball bearings are cleaned in high flash-point solvent then dried with compressed air. Air dry the bearing while holding both races to prevent it from spinning. If the bearing is allowed to spin, the high speed generated by the air jet can overspeed the bearing and cause permanent damage.

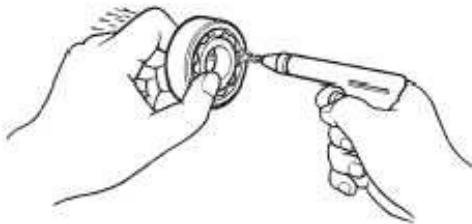

Ball bearings are checked (after cleaning) by slowly rotating the inner race while holding the outer race stationary. If any radial play or roughness is felt, it must be replaced. The bearing should have no axial play; if it has noticeable axial play, it must be replaced.

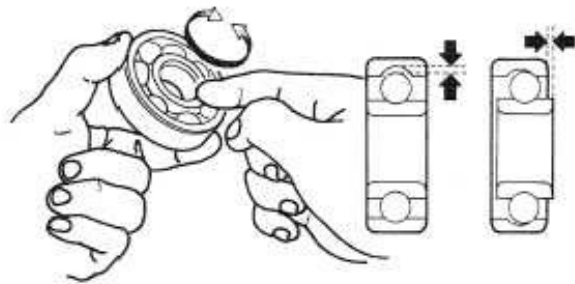

Ball bearings are always installed with the manufacturer's name and size code facing out. (Facing out meaning—the name and sizing code should be visible from the side the bearing is installed from.) This is true for open, single-sealed and double-sealed bearings. Apply the proper grease to open and single sealed bearings before reassembly.

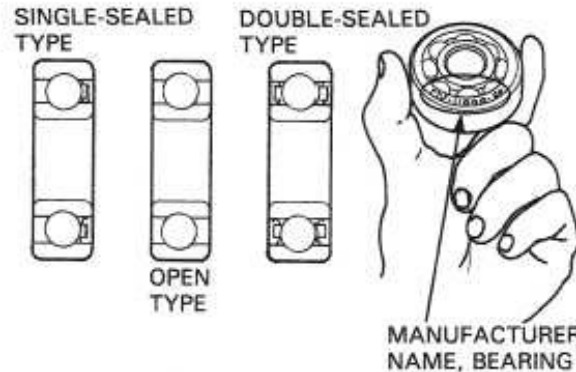

MANUFACTURER'S NAME, BEARING No.

Snap rings are always installed with the chamfered (rolled) edge facing away from the thrust of the mating part. This way, pressure against the snap ring presses against the areas in the snap ring groove with the most parallel contact area against one another. Installed incorrectly, pressure against the rolled or chamfered edge could compress the snap ring with the possibility of dislodging it. Never reuse snap rings since they are often used to control end play and become worn with normal use. Wear is especially critical on snap rings which retain spinning parts such as gears. After installing a snap ring, always rotate it in its groove to be sure it is fully-seated.

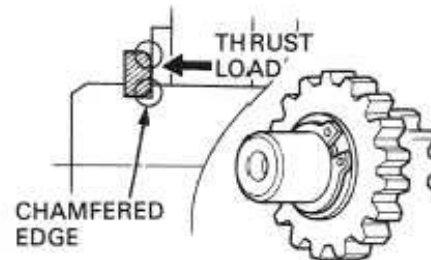

Grease or oil sliding or turning parts with the recommended lubricant before reassembly.

Replacement parts and fluids must be genuine Honda or recommended by Honda. The use of non-Honda parts and non-recommended fluids can have an adverse affect on performance and durability.

Reassembly operation should be tested, whenever possible, before the part is installed onto the motorcycle.

Bolt or screw lengths can vary for an assembly, cover, or case. These different lengths must be installed into the correct locations. If you become confused, place the bolts into their holes and compare the exposed lengths; each should be exposed by the same amount.

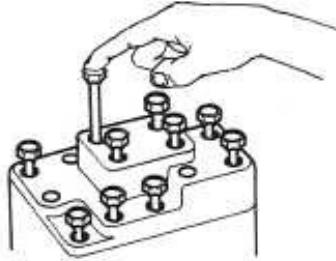

To prevent warping important components and ensure proper gasket sealing, multiple sized fasteners should be torqued as follows: tighten all to hand-tight, then torque big fasteners before little fasteners. Torque pattern should be crisscross from inner-to-outer. To minimize distortion, critical fasteners should be torqued in two or three increments. Unless specified otherwise, bolts and fasteners are installed clean and dry; do not use oil on the threads.

Oil seals are always installed with grease packed into the seal cavity and the manufacturer's name facing the outside (dry side). When installing seals, always check that the shaft over which the seal fits is smooth and free of burrs which could damage the seal.

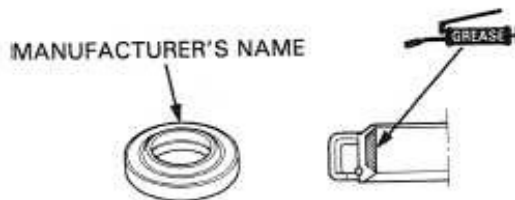

Old gasket material or sealant must be removed before reassembly. If the gasket surface is damaged slightly, it may be possible to smooth that area with an oil stone.

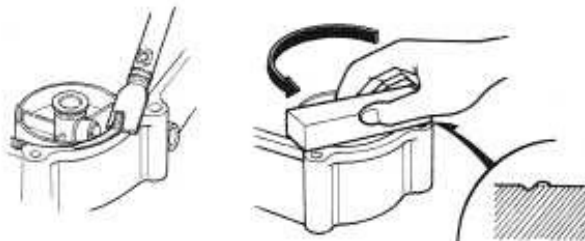

Rubber hoses (fuel, vacuum, or coolant) should be installed so the end is bottomed onto its fitting. This allows adequate area for the hose clip to grip the hose beneath the flared end of the fitting.

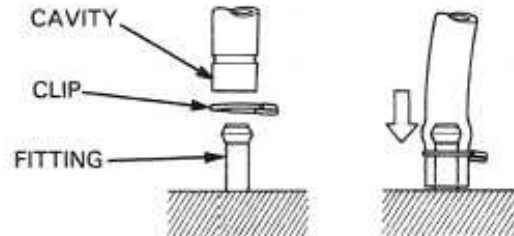

Rubber or Plastic Dust/Dirt Boots should be replaced securely in the exact positions they were designed for.

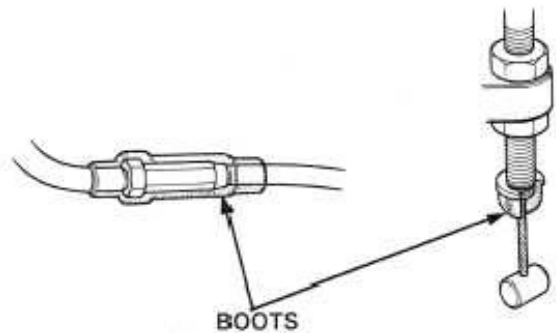

GENERAL INFORMATION

FASTENERS

A motorcycle is composed of a number of connected parts. A variety of fasteners are used to connect these parts. Unlike permanent connection methods like welding, riveting and glueing, threaded fasteners are essential as a means of non-permanent connection which can be disconnected whenever necessary.

Roughly estimated, the thread diameter is the O.D. of the male thread or the I.D. across the full width of the "valleys" of the female thread.

The pitch is the thread-to-thread distance that a male/female bolt moves in one complete turn.

TYPES OF THREADS

Metric threads, as specified by the International Standards Organization (ISO), are used on HONDA motorcycles.

The typical ISO threads found on Honda products are the following threads and pitches.

Diameter (mm)	Pitch (mm)	Diameter (mm)	Pitch (mm)
3	0.5	12	1.25
4	0.7	14	1.5
5	0.8	16	1.5
6	1.0	18	1.5
8	1.25	20	1.5
10	1.25		

The few parts which do not have conventional (ISO) metric threads are listed below.

The threads are NOT INTERCHANGEABLE with conventional (ISO) metric threads.

Description	*Symbols (typical examples)	Example of application
Parallel threads for tubes	PF 1/8	Oil pressure switch
Tapered threads for tubes	PT 1/8	Thermostatic units
Thread type used on bicycles	BC 3.2	Spokes and nipples
Spark plug threads	M 12S	Spark plugs
Automobile tire valve stem	TV8	Tire valve stem

* The figures given above represent screw sizes. An example is given for each type of screw or thread type.

THREAD SIZES

Thread sizes are represented by male thread diameters. Widths across flats represent applicable tool sizes. Note that these widths are not related to thread sizes.

On Honda motorcycles, scooters and ATVs, the size of the bolt, nut or screw is considered to be the thread diameter.

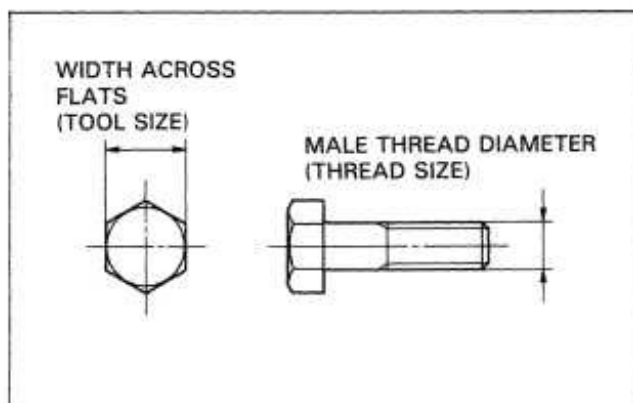
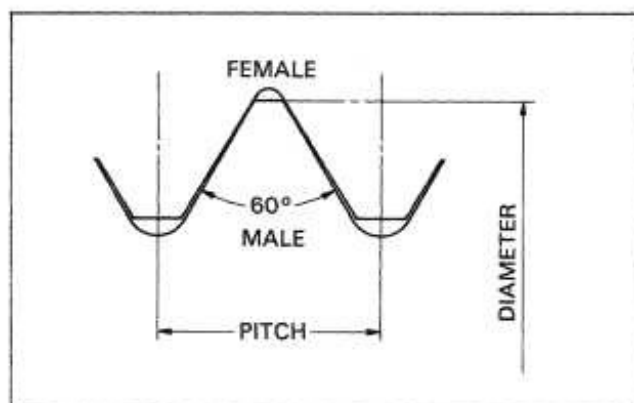

WIDTH ACROSS FLATS

The width across flats is the portion where tools such as a wrench or a socket are applied. Applicable tool sizes are represented by these widths. The denomination of a "10 mm wrench," for example, represents a wrench to be used on hex-heads with widths across flats of 10 mm.

On the right is a table to show representative widths across flats and thread sizes often used for Honda motorcycles. Not all widths across the flats are shown.

Some other common widths across the flats are 22, 24, 27, 30, 32 mm, etc. Spark plugs have particular width across flats; they should be removed with special spark plug wrenches (16, 18 and 20.6 mm).

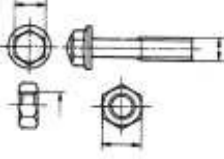
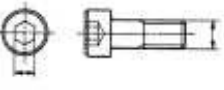
Hexagon portion	Width across flats	(Thread diameter) x (pitch)
	8	5 x 0.8
	8	6 x 1.0
	10	6 x 1.0
	12	8 x 1.25
	14	10 x 1.25
	17	12 x 1.25
	19	14 x 1.5
	5	6 x 1.0
	6	8 x 1.25
	8	10 x 1.25
	10	12 x 1.25

HEX-HEAD BOLT STRENGTH MARKINGS

Strength marks, indicating material type, are visible on the head of some hex-headed bolts. Bolts are classified into standard bolts and high-tension bolts by material types. During assembly, take care not to install any high-tension bolts in the wrong place. Note that while standard bolts are tightened to a standard torque unless otherwise specified, high-tension bolts always have their own specified torque values. 6 mm SH bolts without strength marks (small-headed flange bolts with a width across flats of 8 mm and a thread size of 6 mm) are all considered standard bolts.

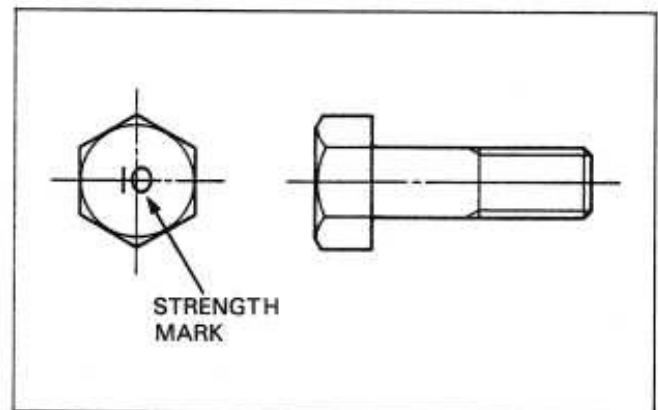

Mark	No mark	⊖ or ⊕	10	12
Strength Class.	5.8	8.8	10.9	12.9
Tension strength	50-70 kg/mm ²	80-100 kg/mm ²	100-120 kg/mm ²	120-140 kg/mm ²
Class.	Standard Bolts		High tension	

DR-type (or dished-headed) bolts without strength markings (flange bolts with hex-heads and weight reduction holes in them) are classified by outer flange diameters. Be careful about the installation points and the torques of high-tension bolts having the same hexagon dimensions as standard bolts, but having larger flanges.

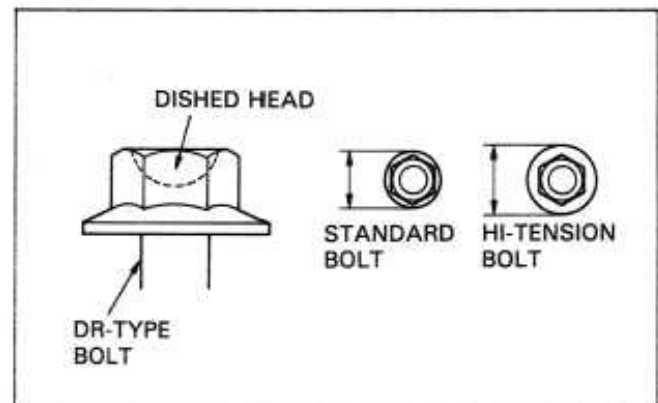

GENERAL INFORMATION

UBS bolts are in the high-tension category. They can be recognized by undercuts under their bolt necks. UBS bolts are marked either with or without strength marks. Furthermore, these bolts are so structured so they will not easily loosen, by the provision of a slight slope of 5 to 60° on the bottom of the flange.

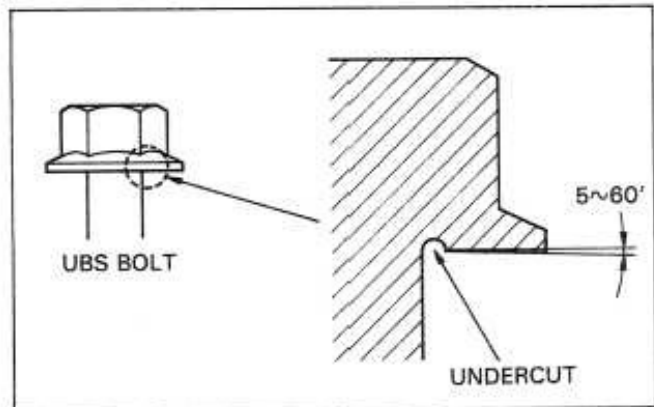

"TORX" BOLT

"TORX" was developed by CAMCAR/TEXTRON INC., Rockford, Illinois, U.S.A.. Its portion which transfers the tightening torque has hex-globe shape as shown in the figure. The inside TORX is classified as "T" type, and the outside TORX is as "E" type.

Drive size represent the sizes of "T" or "E" portion and also applicable tool sizes.

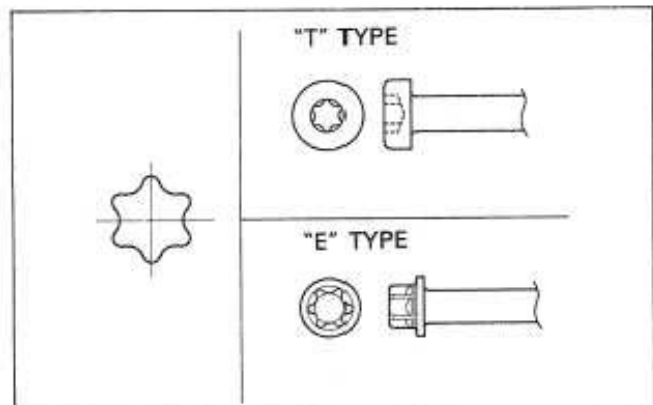

On the right is a table to show representative drive sizes and thread sizes often used for Honda motorcycles.

Thread diameter (mm)	Drive size	
	T type	E type
4	T20	E8 (nut) ———
4.5	T20	—————
5	T25 or T27	E6 (bolt) E10 (nut)
6	T30	E8 (bolt) E12 (nut)
8	T40 or T45	E10 (bolt) E16 (nut)
10	T50	E12 (bolt) E18 (nut)

"T" type TORX has a special type which has a projection at the bottom of its hollow.

This type of TORX bolt is used for the parts not to be disassembled. (ex: throttle sensor installation and etc.)

To remove and install, specific type (with a recess for the projection) of TORX wrench is required.

Be careful that the parts using "T" type TORX bolt basically should not be removed or the adjustment is required when reinstalled.

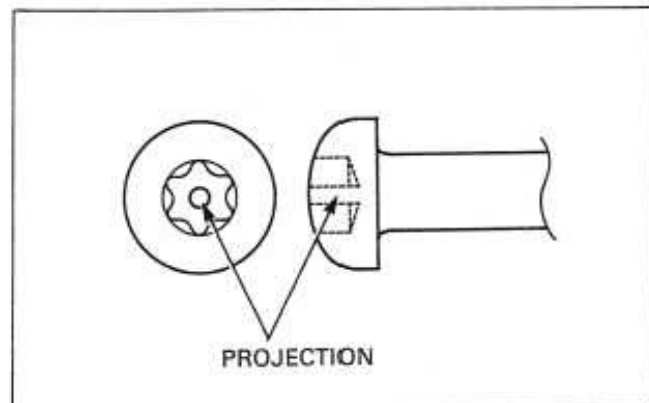

CT BOLT

CT (Combination bolt) makes the female threads when they screw into the unthreaded pilot hole.

The lower half of the CT bolt features the combination of the standard threads and the low threads.

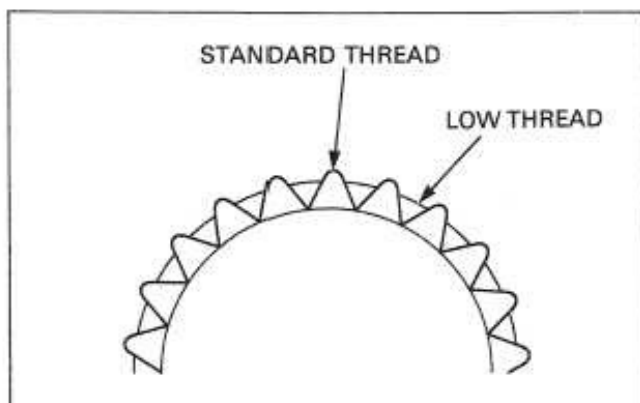

When the CT bolt is screwed into the unthreaded pilot hole, the bolt makes the female threads in the pilot hole by deforming the wall of the hole. Few chips and shavings are produced this time, which is different from threading by a machine.

The threads remain in the part after the CT bolt is removed.

NOTE

- When the CT bolt is reused, tighten the bolt with care not to ruin the female threads that were made when the bolt was tightened first time.
- A standard bolt can be used in the female threads that were made by the CT bolt.
- The service replacement parts already have the threads.

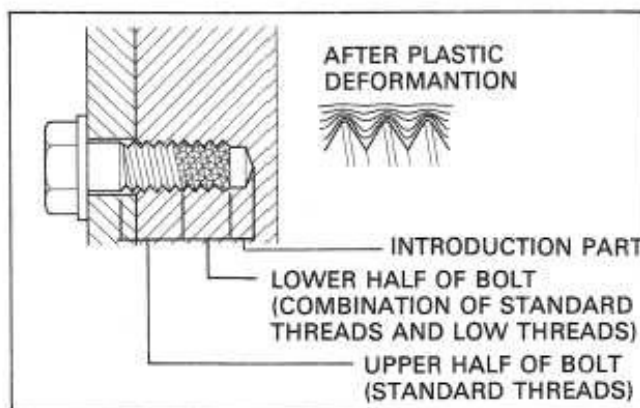

When the CT bolt replacement is required, use a new CT bolt or Honda genuine standard bolt (length l). Do not use the length l' standard bolt.

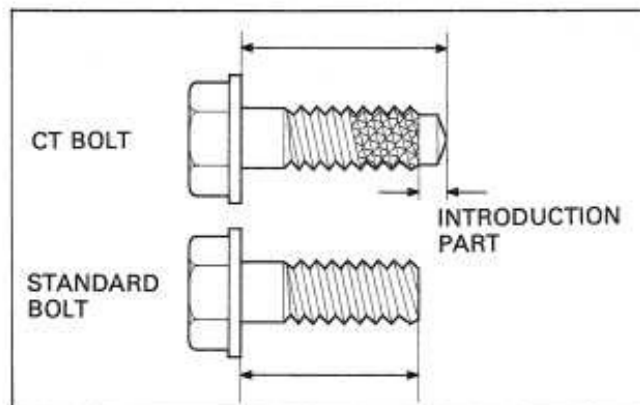

GENERAL INFORMATION

TORQUE VALUES (Tightening Force)

When two or more parts are connected by a fastener, their connection should not be affected by external forces; i.e. there should be no gap between the parts which are fastened together. The first priority of threaded fastener connected parts is the state of being tightened with a sufficient force. When any tightening force is sufficient for the intended function, it is called "proper tightening force".

The tightening force of one bolt is equal to bolt axial tensile strength. Bolt tightening force is, therefore, often called "bolt axial force".

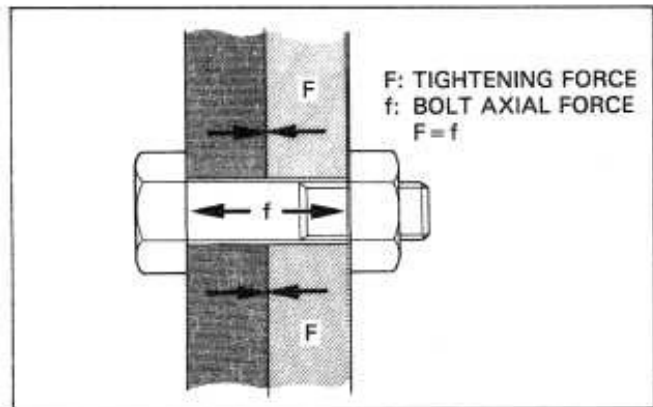

A decrease in tightening force (initial tightening force) due to the passage of time, external forces, or vibration applied during use is called "fastener loosening". Even when the initial tightening force was correct, loosening may cause it to decrease in later use, finally damaging some parts. As a countermeasure against fastener loosening, retightening is carried out after a certain period of time. Periodically tightening wheel spokes is an example of this operation.

Proper tightening forces are specified according to fastener strength, strength of fastened parts and intensity of external forces. Tightening must be carried out in strict accordance with this specification, especially at important points. Tightening a connecting rod bearing cap with a stronger force than is proper, for example, will deform the tightened part (bearing cap) slightly and cause the oil clearance for the bearing to become smaller than specified, which may lead to the bearing seizing. An insufficient tightening force, on the other hand, may allow the nuts or bearing caps to loosen and fall off during engine operation, leading to serious engine trouble.

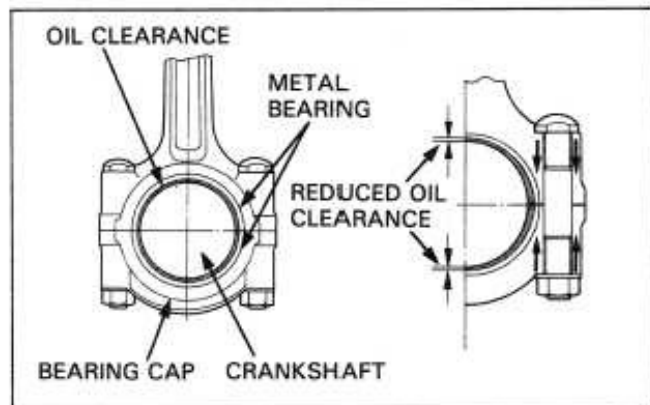

As mentioned earlier, the most important point in fastener tightening is the tightening force. The problem is that this tightening force (axial tension) is difficult to measure. Using a predetermined tightening torque is, therefore, the most common method of controlling fastener tension.

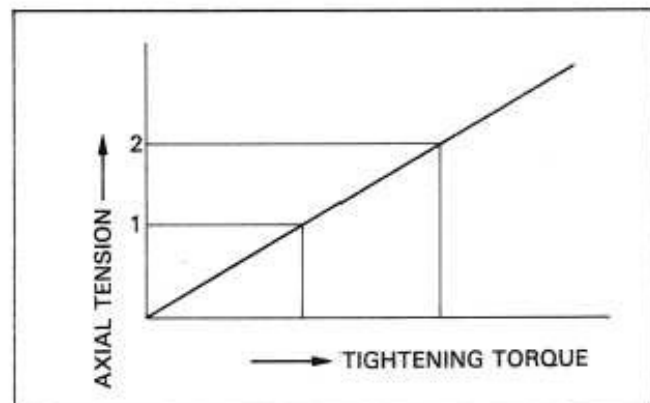

It must be noted that, in this control method using torque values, the axial tension is proportional to the torque under certain conditions. Under other conditions, this important axial tension varies even when the fastener is tightened to the same torque.

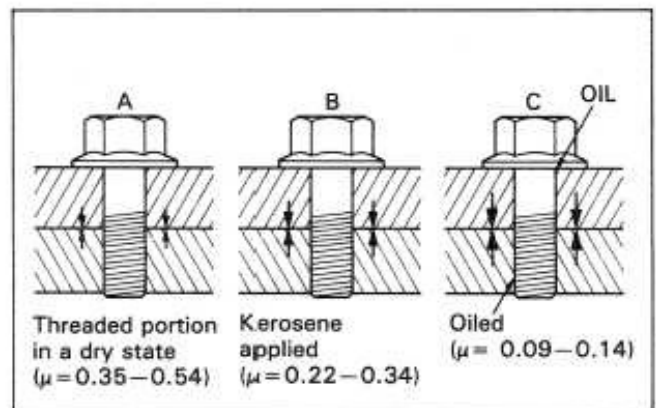

The table on the right gives some examples of friction coefficient $\langle \mu \rangle$ when oil has adhered to the threaded portion. Under the same conditions from the viewpoint of the tightening torque and the material of the parts that are fastened together, $\langle \mu \rangle$ varies largely. Of the tightening torque applied on an unlubricated fastener, 88 to 92 percent is consumed by the friction of flanges and thread surfaces and only 8 to 12 percent is effectively transformed into axial tension. This percentage of transformation into axial tension increases as the above-mentioned friction decreases: i.e. as the value $\langle \mu \rangle$ decreases, the axial tension increases. Axial tension varies when the same tightening torque value is obtained. Furthermore, in a dry (unlubricated) state, the value $\langle \mu \rangle$ varies in a wider range and has a tendency to increase as the tightening/loosening procedure is repeated.

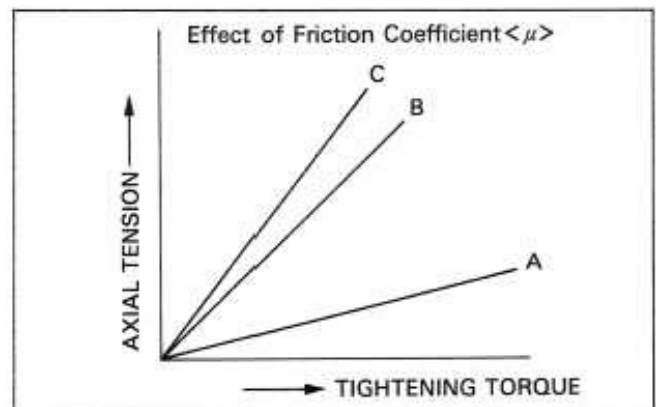

It is important to oil the threads of specific fasteners when instructed to do so in the Model Specific manual. Oiling the threads of these fasteners ensures stable fastening tension in critical areas. No other bolts besides those specifically pointed out in the Model Specific service manual text require oil on their threads.

Lubrication of the threaded portion or of the bottom of the flange reduces friction and the anti-loosening effect. However, this lubrication also increases fastener axial tension and results in a sufficient tightening strength, so that the fastener is less likely to loosen.

Torque values are determined according to fastener size and strength, and the strength of the parts that are fastened together. In many of our previous service manuals, torque values are specified within a certain range. Due to slight variation in torque wrench precision and fastener friction coefficient, the target torque value should be the middle of the range of the torque value specified. The Model Specific manuals provide only the simplified, middle-range torque values. Kg-m is used as a tightening torque unit.

Example; A torque of 1 kg-m refers to the moment of force obtained when a 1-meter long wrench is loaded with 1 kilogram. At the same moment, a heavier load is needed as the effective wrench length is shorter.

$$1 \text{ kg-m} = 10 \text{ N}\cdot\text{m}$$

$$1 \text{ kg-m} = 7 \text{ ft}\cdot\text{lb}$$

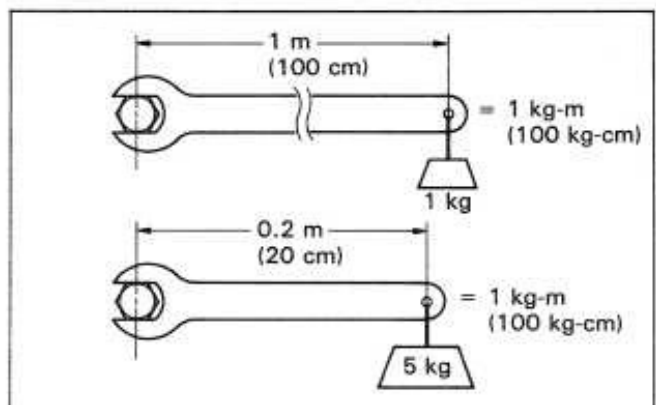

GENERAL INFORMATION

FASTENER LOOSENING

In most of the cases, fastener loosening is due to external forces repeatedly applied to, or working against, the fastener (such as vibration), thus reducing screw axial tension.

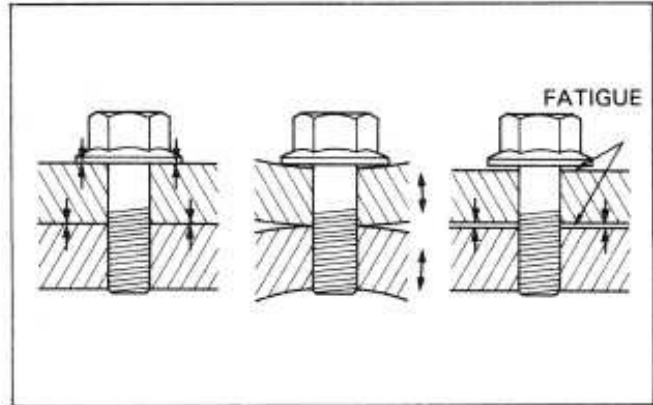

Certain areas of a motorcycle or scooter are subject to repeated and severe external forces. Special bolts with a high percentage of elastic deformation capability are used in these areas.

Installing common bolts in these areas with special requirements may lead to loosening or shearing of the fastener. Therefore it is important to identify both these specially designed bolts and the positions where they are required. Follow any special bolt instructions given in the Model Specific manuals.

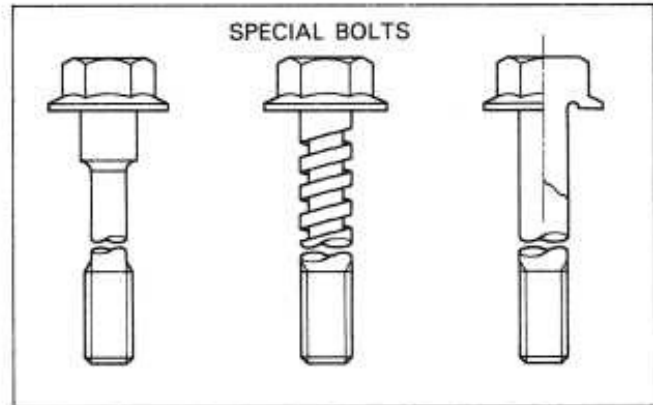

Always clean fasteners thoroughly if there is any dirt present anywhere on the fastener.



Installing fasteners with dirt or other foreign matter on their threads or on the bolt or nut bearing surfaces will result in improper axial tension, despite the use of the proper torque specification.

As the dirt or foreign matter breaks down due to vibration and the attached parts working against each other, the fastener will soon work its way loose.

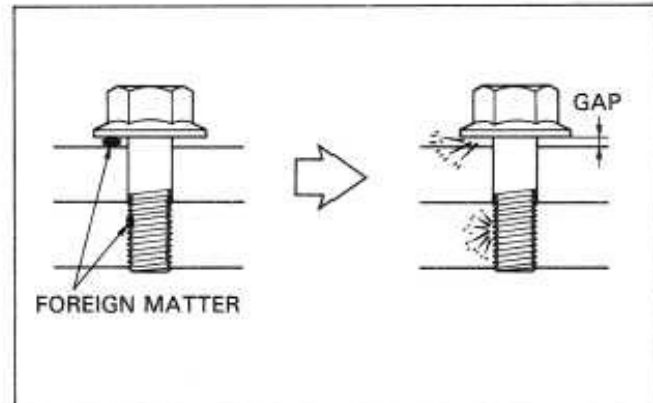

There are several methods of preventing the various types of fasteners from loosening. Some representative examples are presented on the next page, together with the necessary instructions for proper use.

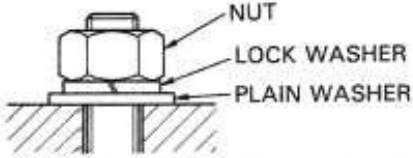
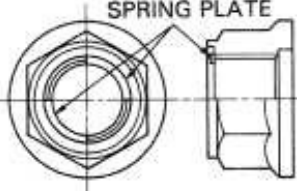
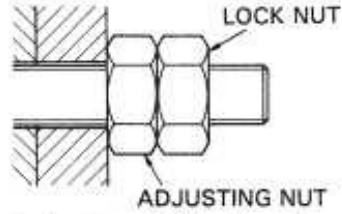
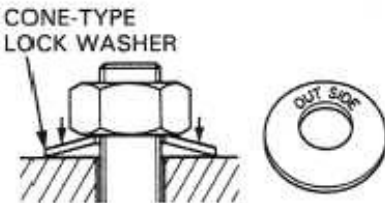

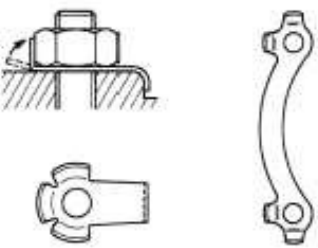
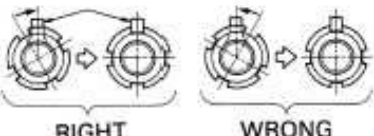
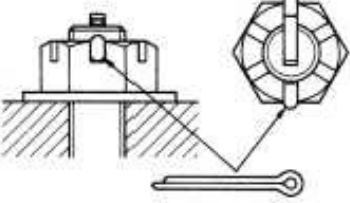
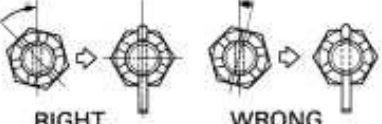

Locking

TYPES OF FASTENERS	APPLICATIONS	CAUTION
<p>1. Lock washer (Conventional splitting type)</p>  <p>LOCK WASHER</p> <p>When the washer is compressed under the bearing surface pressure, the elasticity of the spring and the edges of the ring ends prevent loosening.</p>	<ul style="list-style-type: none"> • Various points on frame (Bolts-incorporating washers are also available.) 	<ul style="list-style-type: none"> • Do not use lock washers which have lost their elasticity or are deformed or eccentric. • Excessive torque will open or deform the washer and render it useless. • Use an appropriate size for thread dia. or hex point. • When using with a plain washer, always put the lock washer between the nut and plain washer.  <p>NUT LOCK WASHER PLAIN WASHER</p>
<p>2. Self-locking nut</p>  <p>SPRING PLATE</p> <p>This is a nut with a spring plate on top. This spring plate presses against the thread, making it difficult for the nut to loosen. After removal, this type of nut can be used again.</p>	<ul style="list-style-type: none"> • Important points on the frame <ul style="list-style-type: none"> – PRO-Link pivot point nuts – Axle nuts 	<ul style="list-style-type: none"> • Avoid using spring plate nuts with deformed or damaged spring plates. • The bolt head must be held during nut installation and removal due to the resistance of the nut spring plate against the bolt. • If the bolt length is too short, the spring plate portion of the lock nut will not engage with the thread fully.
<p>3. Double nut</p>  <p>LOCK NUT ADJUSTING NUT</p> <p>The lock nut, applied to the adjusting nut from outside, presses against the latter thus preventing loosening.</p>	<ul style="list-style-type: none"> • Chain adjusters • Cable adjusters (Also used for removing or installing stud bolts) 	<ul style="list-style-type: none"> • Hold the adjusting nut securely and tighten the lock nut. • Any attempt to loosen both nuts (adjusting and lock nuts) simultaneously will damage the bolt threads.
<p>4. Cone spring lock washer</p>  <p>CONE-TYPE LOCK WASHER</p> <p>The bearing surface presses on the cone spring washer and the spring reaction presses against the nut to prevent it from loosening.</p>	<ul style="list-style-type: none"> • Important points inside the engine <ul style="list-style-type: none"> – Clutch lock nut – Primary gear lock nut • Drive sprocket center bolt 	<ul style="list-style-type: none"> • Installing in the opposite direction prevents effective locking. Always install cone washers with their "OUTSIDE" mark facing out. If unmarked, install cone spring washers as shown in the column at left. • Do not use if damaged or deformed. • When using a lock nut chamfered on one side, install the nut with chamfered side facing the lock washer as shown below.  <p>LOCK NUT CHAMFERED EDGE</p>

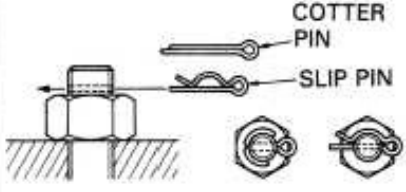
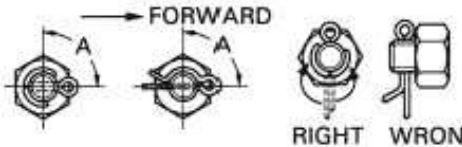
GENERAL INFORMATION

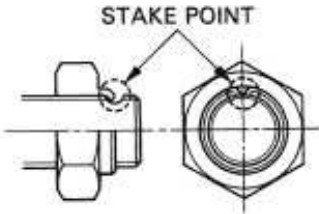
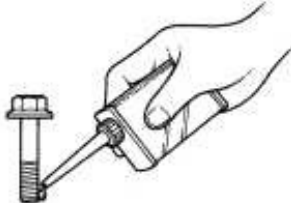
TYPES OF FASTENERS	APPLICATIONS	CAUTION
<p>5. Tongued lock plate</p>  <p>Bend the tongue (claw) to the flat face of nut or into the groove of the nut to lock the nut or bolt head.</p>	<ul style="list-style-type: none"> • Important points inside engine <ul style="list-style-type: none"> – Clutch lock nut • Important safety points on the frame <ul style="list-style-type: none"> – Steering head bearing top nut – Driven sprocket nuts 	<ul style="list-style-type: none"> • Ensure that a tongue (claw) has locked the nut properly. • Since repeated bending/straightening damages the tongue, replace the lock plate with a new one whenever the lock plate is removed. • Align the tongue to the nut in such a manner that the nut aligns perfectly when proper nut torque is reached, or so that the nut must be tightened further to align the tongue. • Do not align the nut in a position where the locking tongue aligns, but the nut torque is less than specified.  <p style="text-align: center;">RIGHT WRONG</p>
<p>6. Castle-headed nut</p>  <p>Inserting a cotter pin through a nut and bolt prevents loosening.</p>	<ul style="list-style-type: none"> • Important safety points on the frame <ul style="list-style-type: none"> – Axle nut – Brake torque rod 	<ul style="list-style-type: none"> • Since repeated bending/straightening damages cotter pins, always use new cotter pins during assembly. • Tighten the nut to the specified torque. Then align the next possible pin hole while tightening the nut just beyond the specified torque. • Do not align the holes in a position where the nut torque is less than the specified torque.  <p style="text-align: center;">RIGHT WRONG</p> <ul style="list-style-type: none"> • Bend the cotter pin as shown below.  <p style="text-align: center;">RIGHT WRONG</p>
<p>7. Slip pin/cotter pin</p>  <p>Inserting a slip pin or cotter pin through a bolt prevents the nut from loosening.</p>	<ul style="list-style-type: none"> • Frame important safety points <ul style="list-style-type: none"> – Brake rod 	<ul style="list-style-type: none"> • Since repeated bending /straightening damages cotter pins, always use new cotter pins during assembly. Although slip pins can be used again, replace slip pins with new ones if they are deformed or fatigued. • When using a cotter pin or slip pin on suspension and wheel components, install the pin with the head facing forward. If installed in the opposite direction, these pins may be bent and eventually broken and knocked out due to hitting stationary objects or from thrown stones on off-road bikes. Be sure to bend cotter pins properly as shown below.  <p style="text-align: center;">FORWARD</p> <p style="text-align: center;">RIGHT WRONG</p> <ul style="list-style-type: none"> • Set the pin head in any position within the range A shown above.

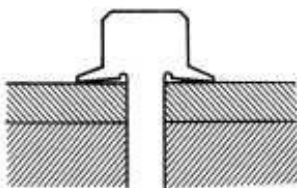
TYPES OF FASTENERS	APPLICATIONS	CAUTION
<p>8. Stake-type lock nut</p>  <p>STAKE POINT</p> <p>Stake (or indent) the collar of the nut to make it match the groove in the shaft.</p>	<ul style="list-style-type: none"> • Important points inside the engine <ul style="list-style-type: none"> – Clutch center lock nut • Wheel bearing retainer • Shift drum stopper plate 	<ul style="list-style-type: none"> • During disassembly, eliminate the staking point to loosen the nut. • Replace the nut, if the old staked area of the nut aligns with the groove of the shaft after tightening the nut to specified torque. • After tightening the nut to the specified torque, stake the nut collar by striking it with a drift punch in such a way that the staking point matches the shaft groove. Ensure that the staking point has entered into the groove at least 2/3 of the groove depth.
<p>9. Thread locking agent</p>  <p>Apply a thread locking agent to the thread to prevent loosening.</p>	<ul style="list-style-type: none"> • Rotating points inside the engine, points which if loosened, may contact rotating parts. <ul style="list-style-type: none"> – Stator coil bolt – Bearing retainer bolts – Shift drum stopper plate bolt • Frame <ul style="list-style-type: none"> – Fork socket bolts – Brake disc bolts 	<ul style="list-style-type: none"> • Application of a locking agent increases loosening torque. Take care not to damage the bolt during removal. • Before applying a locking agent clean off all oil and/or residual adhesive remaining on the threads and dry them completely. • Application of an excessive amount of adhesive may, during loosening, damage the thread or cause the bolt to be broken. Applying a small amount of adhesive to the end of the bolt threads distributes the adhesive throughout when the bolt is threaded in. <p style="text-align: center;">APPLY LOCKING AGENT</p>  <ul style="list-style-type: none"> • Locking agent may cause plastic parts to crack. Don't let locking agent touch plastic parts.
<p>10. UBS bolt</p>  <p>The threads are pressed by the reaction on the inclined bolt flange.</p>	<ul style="list-style-type: none"> • Used on critical areas of the engine/frame where a nut cannot be used to tighten. <ul style="list-style-type: none"> Engine; <ul style="list-style-type: none"> – cylinder – cylinder head Frame; <ul style="list-style-type: none"> – foot peg – bracket 	<ul style="list-style-type: none"> • The tightening surface where the bolt flange seats should be level and smooth.

BALL BEARING REPLACEMENT

Removing Ball Bearings

Ball bearings are removed using tools which apply force against one or both (inner and outer) races. If the force is applied against only one race (either inner or outer), the bearing will be damaged during removal and must be replaced. If the force is applied against both races (equally), the bearing can be reused.

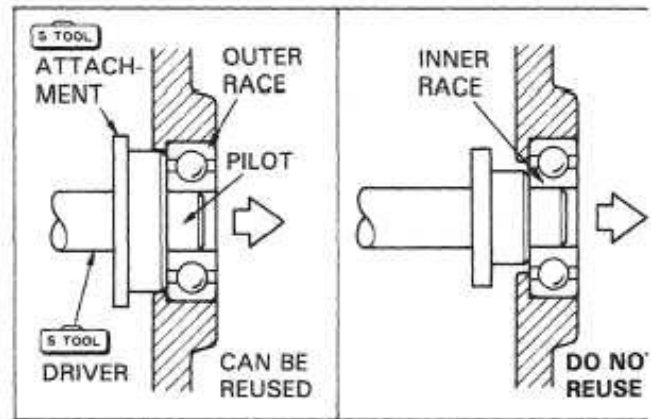

If the bearing is in a blind hole in the crankcase and cannot be removed by hammering on the opposite side, remove it with a bearing remover. For recommended bearing removers, refer to the Tool Compatibility Table on page 1-18 and Chart on page 1-19.

CAUTION

- Operate the bearing remover with the shaft threads properly engaged. A poor fit may lead to damage to the threads.
- Replace the remover if it is worn or damaged.

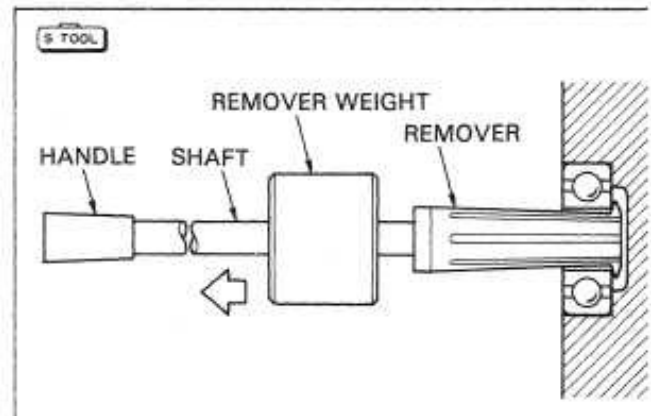

Do not reuse bearings that have been removed.

If the use of a bearing remover is not possible, remove the bearing by thermally expanding the case; slowly and uniformly heating the case with a heat gun (industrial dryer), or a hot plate.

WARNING

- To avoid burns, wear insulated gloves when handling the heated case.

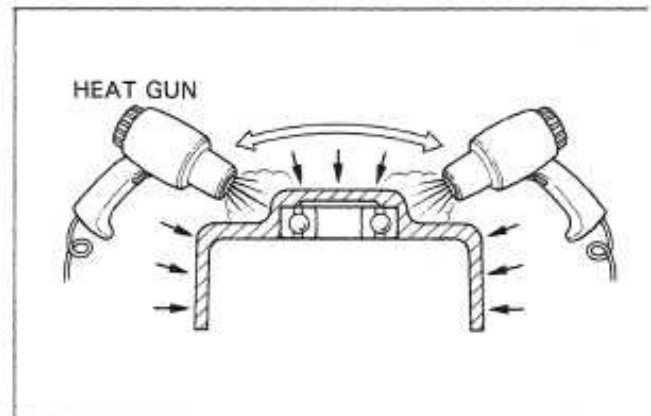

CAUTION

- Using a torch to heat the case may cause warping.

Remove the bearing from the shaft using a bearing puller. Avoid using a bearing that has been removed by pulling on the outer race with a bearing puller.

5 TOOL

Universal Bearing Puller

07631-0010000 or its equivalent should be used.

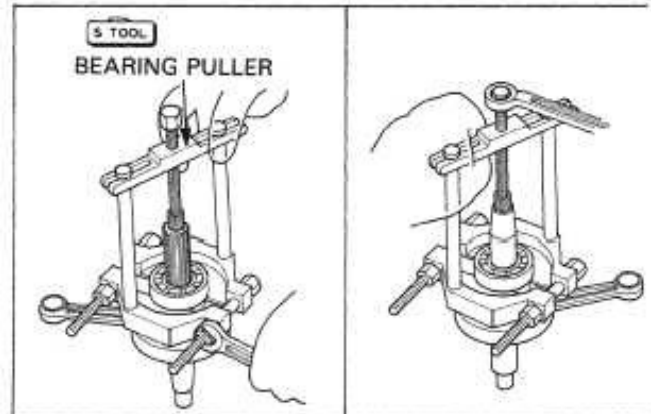

Remove the wheel bearing using a bearing remover shaft and remover head.

Do not reuse the removed bearing.

For recommended bearing remover shafts and remover heads, refer to the Tool Compatibility Charts on the following pages.

Installing Ball Bearings

Clean the bearing recess before the bearing is installed to ensure that it is free from dust or debris and that the bearing seats fully in its recess.

Caution should be taken regarding the direction in which the bearing is installed. Ball bearings are always installed with the manufacturer's name and size code facing out.

This is true for open, single sealed and double sealed bearings.

Apply the proper grease to the bearing before reassembly. The outer race should be installed with a driver, attachment and pilot.

The bearing must be installed in a parallel manner.

CAUTION

- Dust in the bearing recess or failure to install the bearing parallel to the case may result in bearing failure.

If a new bearing fails to fit tightly in the bearing recess, replace the case.

NOTE

- If there is an oil guide plate, the pilot must not be used.

CAUTION

- If the pilot contacts the oil guide plate when installing the bearing, the oil guide plate may be damaged.
- Before removing the bearing, make sure whether or not a pilot can be used.

When the bearing is installed onto a shaft, the inner race should be set by using an inner driver handle and inner driver.

Clean the bearing recesses thoroughly before installing the new bearing.

The bearing must be installed in a parallel manner.

CAUTION

- Dust in the bearing recess or improper fit may result in bearing failure.

If a new bearing fails to fit tightly onto the shaft, replace the shaft.

CAUTION

- An improper fit between the bearing and shaft may cause bearing damage when in use.

For adaptability between drivers, attachments and pilots, refer to the Tool Compatibility Charts on the following pages.

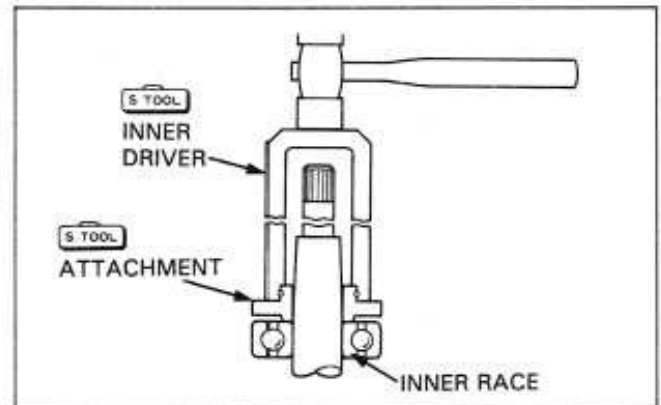
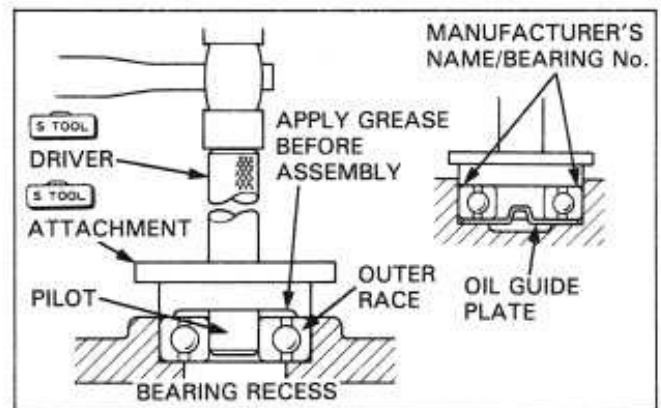
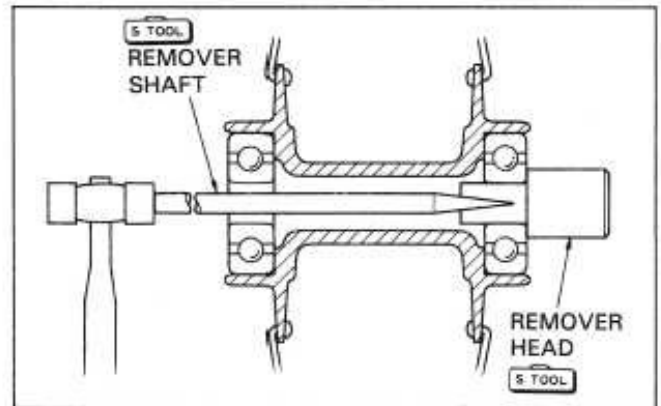

GENERAL INFORMATION

TOOL COMPATIBILITY CHART FOR STANDARD BEARINGS

Bearing Size

Select the bearing tool according to the size stamped on the bearing race.

A "U" or "Z" indicates a bearing with a metal shield or rubber seal respectively. These letters have no connection with bearing size and can be ignored.

- U: Single-sealed type
- Z: Single-sealed type
- UU: Double metal sealed type
- ZZ: Double rubber sealed type

Bearing Remover Compatibility for Wheel Bearing

Use the remover heads listed below in combination with shaft (07746-0050100).

There is a kit comprising of 10-20 mm remover heads and shafts.

S TOOL

Wheel Bearing Remover Kit:

07746-0050001
equivalent commercially
available in U.S.A.
Refer to Service Tool
Catalog, General Tool
STN-#38 in U.S.A.

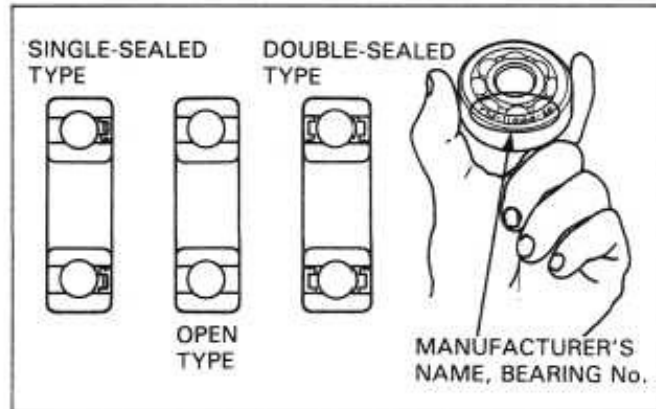

BEARING NUMBER	ID (mm)	BEARING REMOVER HEAD TOOL NUMBER
6000 6200 6300	10	07746-0050200
6001 6201 6301	12	07746-0050300
6002 6202 6302	15	07746-0050400
6003 6203 6303	17	07746-0050500
6004 6204 6304	20	07746-0050600

Bearing Remover Compatibility Table

*Not available in U.S.A. **07936-3710100 U.S.A. only ***07936-3710200 U.S.A. only

BEARING NUMBER	ID	OD	TOOL NUMBER				
			BEARING REMOVER	SHAFT	HANDLE	WEIGHT	REMOVER SET
6000 6200 6300	10	26 30 35	*07936-GE00200	07936-GE00100	Included with shaft	07741-0010201 ***	*07936-GE00000
6001 6201 6301	12	28 32 37	07936-1660110	*07936-1660120	**Included with shaft	07741-0010201 ***	*07936-1660001
6002 6202 6302	15	32 35 42	*07936-KC10200	*07936-KC10100	**Included with shaft	07741-0010201 ***	*07936-KC10000, 07936-KC10500 (Does not include weight)
6003 6203 6303	17	35 40 47	07936-3710300	Included with remover	07936-3710100	07741-0010201 ***	—
6004 6204 6304	20	42 47 52	07936-3710600	Included with remover	07936-3710100	07741-0010201 ***	*07936-3710001
6005 6205 6305	25	47 52 62	*07936-4250100	Included with remover	07936-3710100	07741-0010201 ***	—
6006 6206 6306	30	55 62 72	*07936-8890200	Included with remover	07936-3710100	07741-0010201 ***	*07936-8890101 07936-8890300 (Does not include weight)
6007 6207 6307	35	62 72 80	07936-3710400	Included with remover	07936-3710100	07741-0010201 ***	—

Tool Compatibility Chart

FITTING POINT			OUTER RACE														INNER RACE																	
			ATTACHMENT							PILOT							DRIVER	ATTACHMENT	INNER DRIVER B	ATTACHMENT	INNER DRIVER C													
TOOL NAME	TOOL NUMBER	BEARING OD (mm) ID (mm) SIZE (mm)	07746-0010700	07946-1870100	07746-0010100	07746-0010200	07746-0010300	07746-0010400	07746-0010600	07746-0010800	075AD-SD4010T	07746-0040100	07746-0040200	07746-0040300	07746-0040400	07746-0040500	07746-0041000	07746-0040600	07746-0040700	07746-0040800	07746-0040900	07746-0010001	07746-0020200	07746-0020300	07746-0020400	07746-0020100	07746-0030200	07746-0030300	07746-0030400	07746-0030100				
			24 x 28	28 x 30	32 x 35	37 x 40	42 x 47	52 x 55	62 x 68	72 x 75	78 x 90	10	12	15	17	20	22	25	30	35	40	-	15	17	20	(22)	25	30	35	1401				
6000	10	26	•																			•												
6001	12	28		•									•										•											
6002	15	32			•									•									•				•							
6003	17	35				•									•								•					•						
6004	20	42						•								•							•											
6005	25	47							•								•						•											
6006	30	55								•								•					•											•
6007	35	62									•								•				•											•
6008	40	68																		•			•											•
6009	45	75																					•											•
6200	10	30			•								•										•											
6201	12	32				•								•									•											
6202	15	35					•								•								•											
6203	17	40						•								•							•											
6204	20	47							•								•						•											
6205	25	52								•								•					•											
6206	30	62									•								•				•											
6207	35	72																					•											
6208	40	80																					•											
6210	50	90																						•										
6300	10	35				•								•									•											
6301	12	37					•								•								•											
6302	15	42						•								•							•											
6303	17	47							•								•						•											
6304	20	52								•								•					•											
6305	25	62									•								•				•											
6306	30	72																					•											
6307	35	80																					•											
6308	40	90																					•											
62/22	22	50																					•											
63/22	22	56																					•											
16002	15	32				•																	•											
16003	17	35					•																•											
16004	20	42						•															•											
16005	25	47							•														•											
16006	30	55								•													•											
16007	35	62									•												•											
16008	40	68										•											•											

MEMO

2. MAINTENANCE

2

FUEL LINE	2-2	DRIVE CHAIN	2-21
FUEL STRAINER SCREEN	2-2	DRIVE CHAIN SLIDER, CHAIN GUIDE, GUIDE SLIDER AND ROLLERS	2-27
THROTTLE OPERATION	2-3	DRIVE BELT	2-27
OIL PUMP AND OIL LINE (2-stroke separate oil supply motorcycles)	2-4	BELT CASE AIR CLEANER	2-28
CARBURETOR CHOKE	2-5	FINAL DRIVE OIL LEVEL	2-28
AIR CLEANER	2-6	BATTERY	2-29
AIR CLEANER HOUSING DRAIN TUBE (off-road motorcycles and ATVs)	2-7	BRAKE FLUID	2-30
CRANKCASE BREATHER	2-7	BRAKE SHOE WEAR	2-31
SPARK PLUG	2-8	BRAKE PAD WEAR	2-31
VALVE CLEARANCE	2-9	BRAKE SYSTEM	2-32
ENGINE OIL	2-11	BRAKE LIGHT SWITCHES	2-35
ENGINE OIL FILTER	2-13	HEADLIGHT AIM	2-35
ENGINE OIL FILTER SCREEN	2-14	CLUTCH SYSTEM	2-36
DECARBONIZING (2-stroke engine)	2-15	SIDE STAND	2-37
CARBURETOR SYNCHRONIZATION	2-16	SUSPENSION	2-38
CARBURETOR IDLE SPEED	2-17	SPARK ARRESTER (USA only)	2-40
RADIATOR COOLANT	2-17	NUTS, BOLTS, FASTENERS	2-40
COOLING SYSTEM	2-18	WHEELS/TIRES	2-41
SECONDARY AIR SUPPLY SYSTEM	2-19	STEERING HEAD BEARINGS	2-43
EVAPORATIVE EMISSION CONTROL SYSTEM	2-19	WHEEL ALIGNMENT (FOUR TRAX)	2-43
TRANSMISSION OIL (2-stroke engine)	2-20		

NOTE

- This section covers the normal inspections and adjustments that are necessary to maintain the vehicle in good condition. Perform this maintenance at each scheduled maintenance period. Refer to the Model Specific manual for the proper maintenance schedule and applicable items.

MAINTENANCE

FUEL LINE

Check the fuel line for:

- Gasoline leakage
- Loose or improperly positioned line clip
- Deteriorated or damaged line

Replace any defective parts.

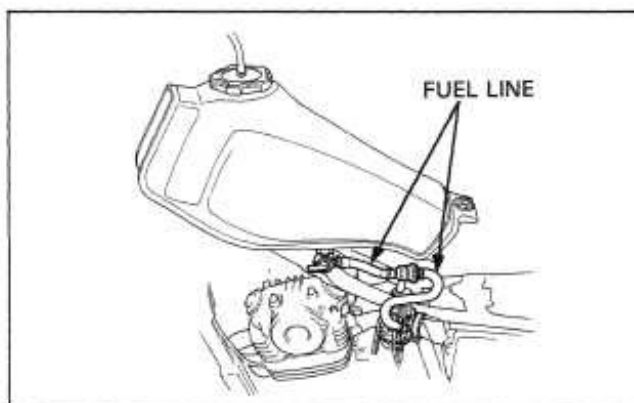

FUEL STRAINER SCREEN

Turn the fuel valve to "OFF" position.

Remove the strainer cap below the fuel valve, and drain the gasoline into a suitable container.

⚠ WARNING

- Gasoline is extremely flammable and is explosive under certain conditions.

Work in a well ventilated area. Keep cigarettes, flames or sparks away from the work area or any area where gasoline is stored.

Remove the O-ring and strainer screen.

Clean the cup and strainer screen with non-flammable or high flash point solvent.

Replace the O-ring with a new one.

Reinstall the strainer screen, O-ring and cup, then tighten the cup to the specified torque.

CAUTION

- Overtightening the cup may break or deform the O-ring, causing a fuel leak.

Turn the fuel valve to "ON" and check that there are no leaks.

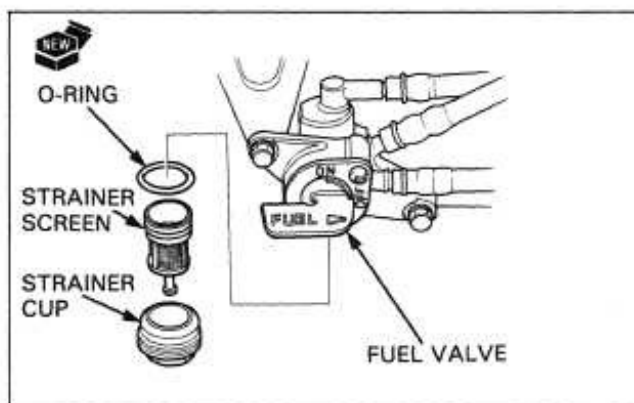

THROTTLE OPERATION

Check for any deterioration or damage to the throttle cable. Check that the throttle automatically closes completely in all steering positions.

If the throttle grip does not return properly, lubricate the throttle cable and overhaul and lubricate the throttle grip housing. If the throttle grip still does not return properly, the cable may need replacement.

With the engine idling, turn the handlebar all the way to the right and left to ensure that the idle speed does not change. If idle speed increases, check the throttle grip free play and the throttle cable connection.

▲ WARNING

- Reusing a damaged or abnormally bent or kinked throttle cable can prevent proper throttle slide operation and may lead to a loss of throttle control while riding.

Throttle free play should be checked and adjusted as follows:

Throttle grip free play is correct if there is a prescribed amount of play on the outer circumference of the throttle grip flange.

Throttle lever free play is correct if there is a prescribed amount of play at the tip of the throttle lever.

Minor free play adjustments can be made with the adjuster on the throttle grip side.

Loosen the lock nut and turn the adjuster to obtain the desired amount of free play.

Tighten the lock nut after the adjustment has been made.

If the adjuster has a boot, reposition it properly after adjustment is made.

With a forced opening/closing-type throttle, the major adjustment of free play can be made by loosening the lock nut on the pull side of the cable and turning the adjuster.

Tighten the lock nut after the adjustment has been made.

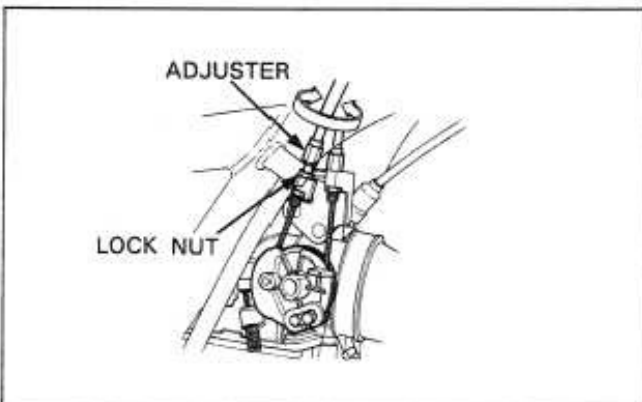
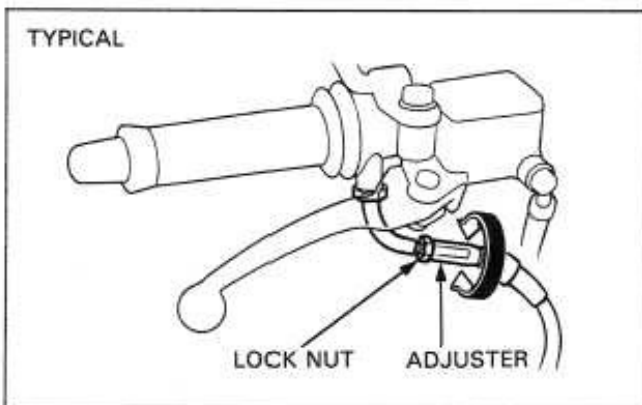
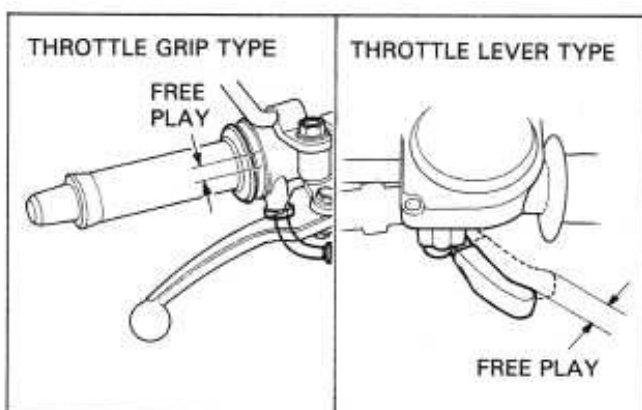
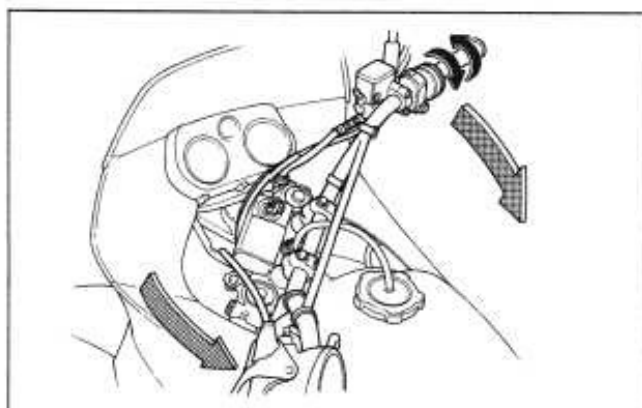

MAINTENANCE

If the throttle cable has an adjuster anywhere within its length besides the ends, major adjustment is made there.

Adjust the free play by loosening the lock nut and turning the adjuster.

Tighten the lock nut after the adjustment has been made. If the adjuster has a boot, reposition it properly after adjustment is made.

After adjustment, verify correct throttle free play in all steering positions.

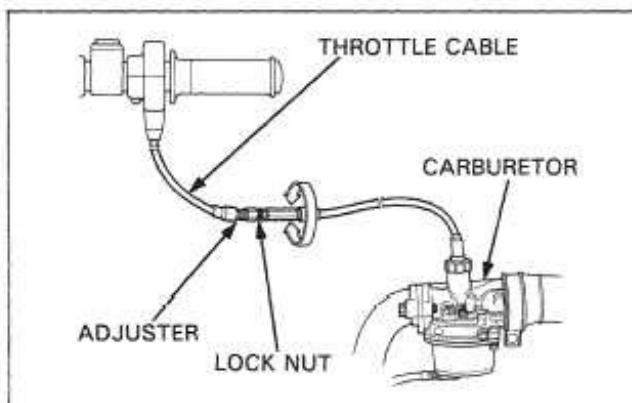

OIL PUMP AND OIL LINE (2-stroke separate oil supply motorcycles)

The oil supply on some 2-strokes is controlled by a throttle cable that is coupled with an oil pump.

Oil flow is regulated, in a direct relation to throttle movement and position, by a combined oil control/throttle cable that simultaneously moves the throttle slide in the carburetor and a control arm on the oil pump.

When the inner cable of the oil control cable stretches, the amount of the oil flow changes and is not suitable for the size of throttle opening. Therefore, it is necessary to inspect and readjust it periodically.

There is matching mark on the oil pump that must be aligned with the matching mark on the control arm, pump body, etc. Refer to the Model Specific manual before making any adjustments.

Oil line

Check the oil line for leaks, deterioration or damage: Replace parts if necessary.

Oil strainer

Loosen the tube clip located on the bottom of the oil tank. Drain oil into a suitable container. Remove the oil strainer joint from the bottom of the tank.

Remove the strainer screen.

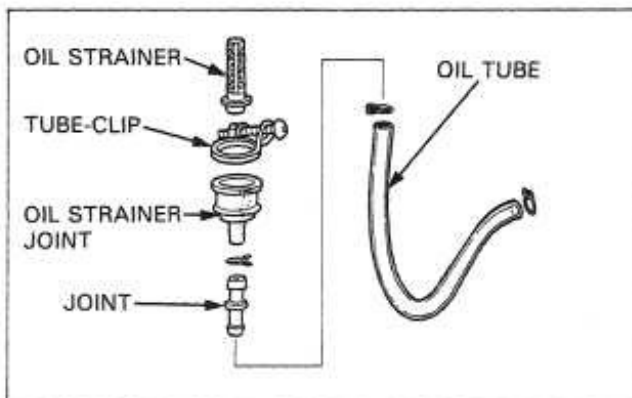
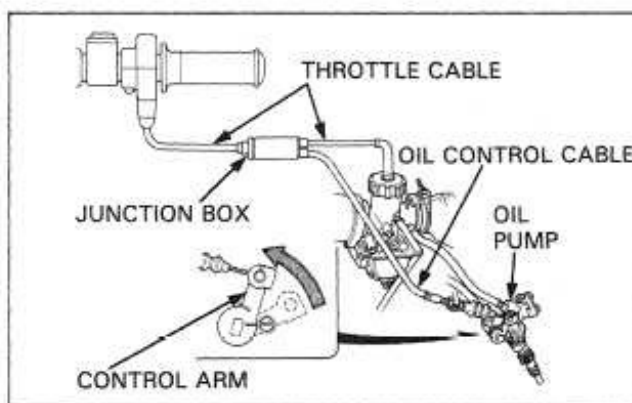

Clean the strainer screen by blowing it out with compressed air.
To replace the screen, reverse the removal procedure.
Fill the oil tank to the upper level mark with 2-stroke engine oil.
Remove any air from the oil line and oil pump (See page 4-11).

NOTE

- Check each part for oil leakage after completing the oil strainer cleaning and oil tube and pump air bleed procedures.



CARBURETOR CHOKE

MANUAL CHOKE

On a manual choke system, check to see if the choke lever (or knob) can be opened and closed completely.

Inspect the choke cable to see if it is bent, crimped or damaged in any way.

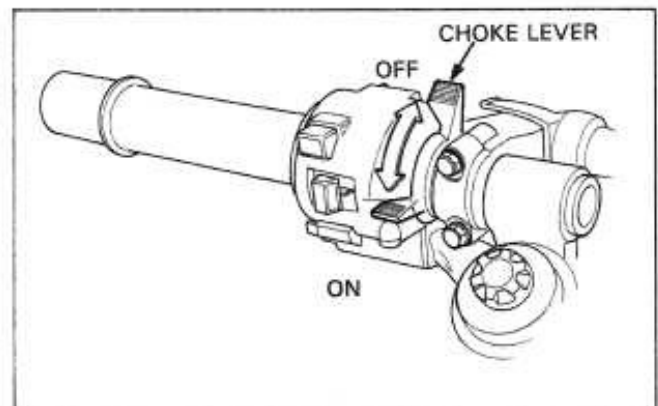

Check to be sure that cable movement is correct on machines with manually operated chokes.

Check by pushing with your finger to see if there is a maximum of 1–2 mm of free play in the inner choke cable when the choke lever is in its completely off position.

If the amount of free play is not sufficient, loosen the cable clamp screw and adjust the play of the inner cable by moving the position of the outer cable. Tighten the cable clamp securely when the adjustment is complete.

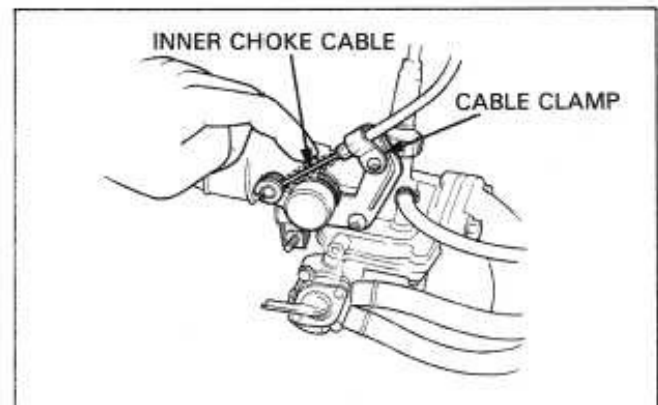

STARTING ENRICHMENT VALVE

The choke action on motorcycles equipped with a starting enrichment valve can be checked by the way the engine starts and runs.

NOTE

- Difficulty in starting before it is warmed up (easy once it is warmed up) : starting enrichment valve is not completely opened (off).
- Idle speed is erratic even after warm-up (imperfect combustion) : starting enrichment valve is not completely closed (on).

When the above-mentioned symptoms occur, inspect and overhaul the starting enrichment system according to the procedures specified in the Model Specific manual. If you find nothing wrong with it, proceed with the overhaul of the other items on the breakdown diagnosis list.

MAINTENANCE

AIR CLEANER

When the element becomes dirty, the air/fuel mixture will become too rich.

Periodic cleaning or replacement is necessary. Vehicles used in dusty areas require more frequent inspections.

When replacing the air cleaner element, be careful to note the following points:

NOTE

- If the element joint has a rubber seal, the joint will become more airtight if a small amount of grease is applied to the seal.
- Check to see that both the air cleaner and the holder are clean and properly secured.

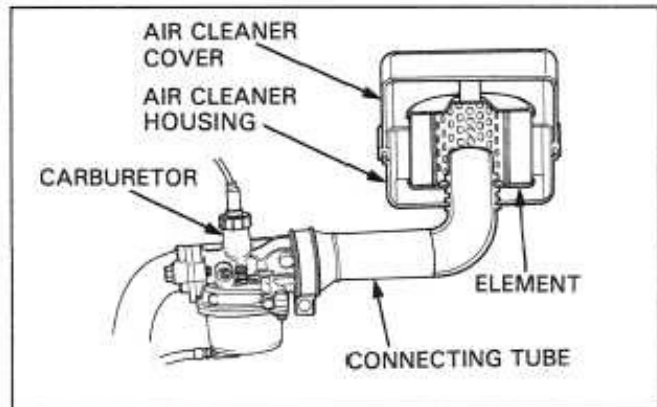

Oiled Urethane Foam Element

Remove the air cleaner from the holder and wash away any accumulated dust or dirt, by gently squeezing it in non-flammable or high flash point solvent.

▲ WARNING

- Using gasoline or low flash point solvents for cleaning parts may result in a fire or explosion.

CAUTION

- Cleaning the element with gasoline or any acid, alkaline, or organic, volatile type oil may cause improper ignition, deterioration of the element, or a loosening of the element adhesive, that can result in engine damage.

Be sure to allow the element to dry thoroughly before applying oil. Otherwise, the oil will be diluted by the solvent and the filtering ability of the filter will be much less effective.

Apply Pro Honda Air Filter Oil or equivalent to the entire surface of the element and rub it with both hands to saturate the element with oil. Squeeze out the excess oil. Apply a thin coat of Pro Honda White Lithium Grease, or equivalent to the sealing surface.

CAUTION

- Failure to use air filter oil when riding in extremely dusty condition can result in premature engine wear due to dust/dirt drawn into the engine.

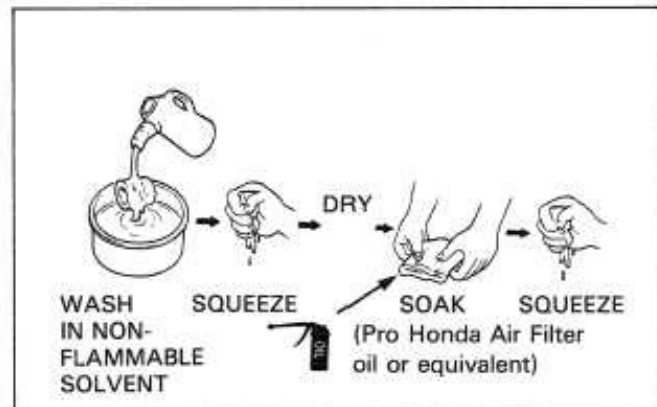

Paper Element

If the surface of the element is dirty, remove the dust first by tapping the element gently. Then, blow away any remaining dust on the surface of the filter with compressed air from the clean side (or carburetor side) toward the dirty side.

Viscous Paper Element

This particular type of paper element cannot be cleaned as the element contains a dust adhesive. These must be changed periodically.

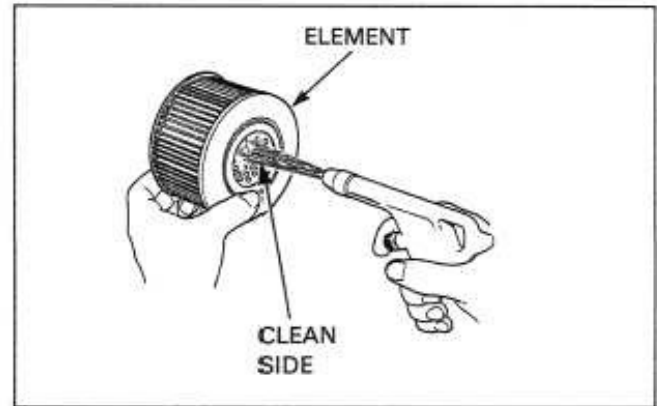

AIR CLEANER HOUSING DRAIN TUBE (off-road motorcycles and ATVs)

Loosen the drain tube clip and remove the drain tube to empty any accumulation of fluids or dirt from the air cleaner housing into a proper container.

Check the drain tube for damage and replace if necessary. Reinstall the drain tube and set the clip in place.

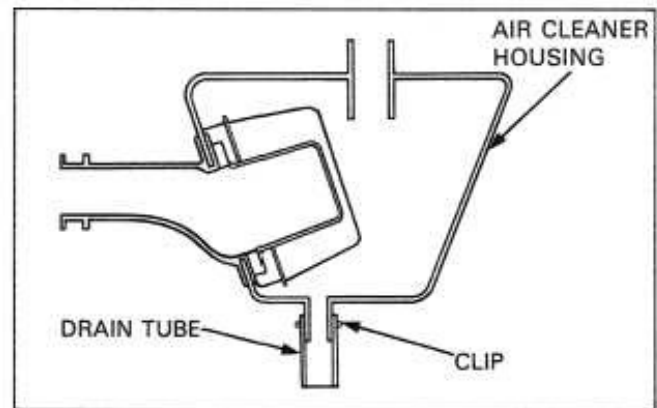

CRANKCASE BREATHER

Honda motorcycle engines are equipped with a closed crankcase system to prevent discharging crankcase emissions into the atmosphere. Blow-by gas is returned to the combustion chamber through the air cleaner and carburetor.

A crankcase breather separator is necessary within the system to prevent moisture from contaminating the engine. Vapor is allowed to pass through the air cleaner and into the engine to be burned off. Moisture is collected in a sealed crankcase breather tube. Periodic maintenance is to remove the and drain deposits into a suitable container, then reinstall the crankcase breather tube plug.

A portion of the crankcase breather tube is transparent so it is easy to confirm the amount of accumulation.

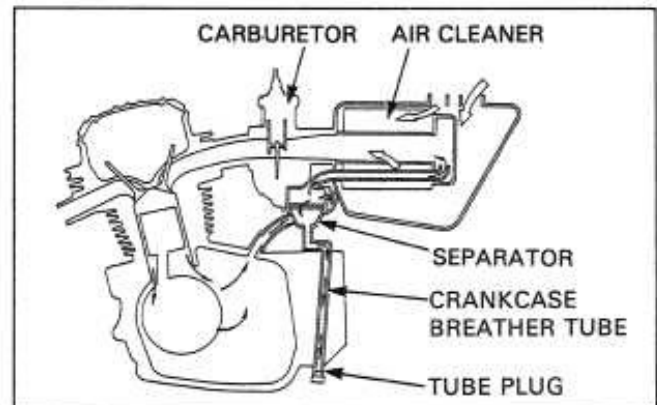

MAINTENANCE

SPARK PLUG

For more information on spark plugs refer to page 23-9.

NOTE

- Clean around the spark plug seat with compressed air before removing, and be sure that no debris is allowed to enter the combustion chamber.

Remove the spark plug cap and then remove the spark plug and inspect or replace as described in the Model Specific manual maintenance schedule.

Inspection

Check the following and replace if necessary.

- insulator for damage
- electrodes for wear
- burning condition, coloration;
 - dark to light brown shows good condition.
 - excessive lightness shows faulty ignition timing or lean mixture.

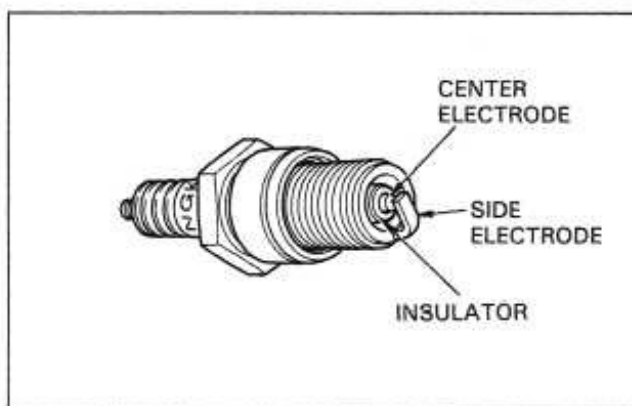

REUSING A SPARK PLUG

Clean the spark plug electrodes with a wire brush or special plug cleaner.

Check the gap between the center and side electrodes with a wire-type feeler gauge. If the gap is not as specified, bend the side electrode to adjust it.

Replace the spark plug in the cylinder head and hand tighten. Torque to specification.

CAUTION

- Make sure there is no dirt or debris on the seat of the spark plug hole before inserting the spark plug.
- To prevent damage to the cylinder head, hand-tighten the spark plug before using a wrench to tighten to the specified torque.

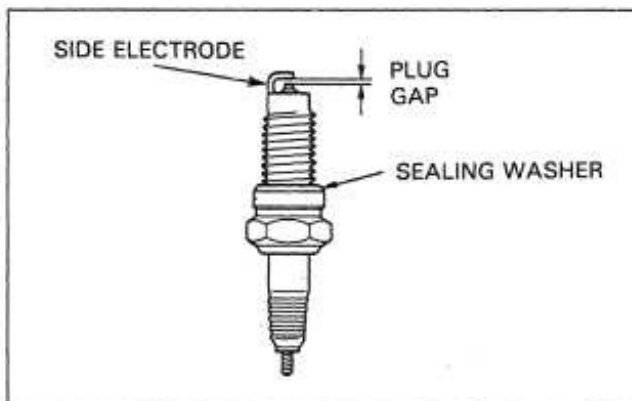

REPLACING A SPARK PLUG

In the case of new spark plugs, set the gap with a wire-type feeler gauge. Install and hand tighten, then tighten about 1/4 of a turn after the sealing washer contacts the seat of the plug hole. Reused plugs should be tightened to the specified torque.

Do not overtighten the spark plug.

CAUTION

- Overtightening the spark plug may damage the cylinder head. Be sure to use the proper spark plug torque.

VALVE CLEARANCE

Adjustment is unnecessary on motorcycles equipped with hydraulic lash adjusters (hydraulic tappet). However, appropriate clearance is needed between both the intake and exhaust valves and the valve opening/closing mechanisms in all other 4-cycle engines. This clearance allows for a change in the size of the valve caused by thermal expansion as the heat of the combustion chamber is transmitted to the valve.

If there is too much clearance, it may result in engine noise (tappet noise). If there is too little clearance, the valve is pushed during the heated period, causing a drop in compression, resulting in bad idling and, eventually, burned valves.

NOTE

- Inspect and adjust the valve clearance when the engine is cool (under 35°C/95°F).

Inspection and adjustment of valve clearance should be performed with the piston at top dead center of the compression stroke. This position can be obtained by confirming that there is slack in the rocker arm when the stamped "T" mark on the flywheel rotor and the index mark on the crankcase cover are aligned. If there is no slack in the rocker arm, even when the T-mark and index mark are aligned, it is because the piston is moving through the exhaust stroke to top dead center. Turn the crankshaft one full rotation and match up the T-mark again. The piston will then be at the top of the compression stroke (top dead center). On in-line 4-cylinder engines with the firing order 1-2-4-3, the inspection of valve clearance can be conducted by rotating the crankshaft twice. After the above procedure has been properly carried out, the inspection and adjustment of all cylinders is complete.

(In-line 4 cylinder engines are numbered 1-2-3-4 starting from the left cylinder.)

Cylinder at top of compression stroke	Cylinder number			
	#1	#2	#3	#4
#1	IN,EX	EX	IN	—
#4	—	IN	EX	IN,EX

On V-twin and V-4 engines, inspection and adjustment are performed by placing each cylinder in the compression, top dead center position.

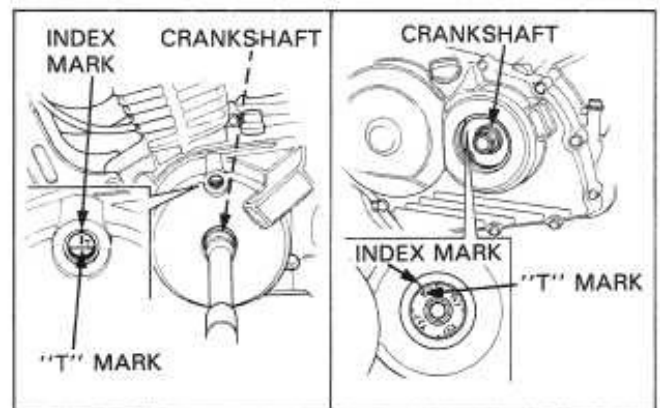
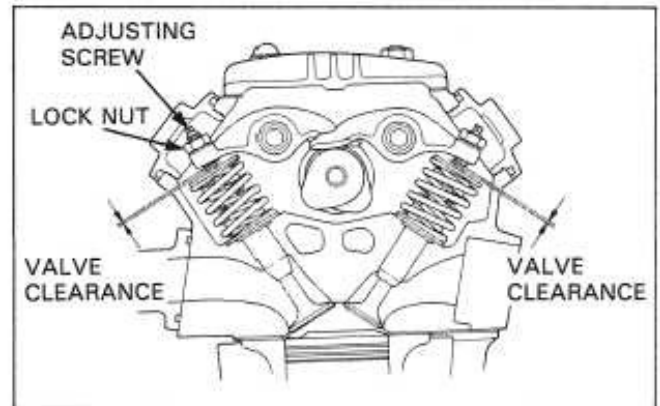

MAINTENANCE

The valve clearance adjustment is correct when the specified feeler gauge fits snugly, but the next size larger feeler gauge will not fit in.

NOTE

- On motorcycles that have a decompression mechanism which lifts the valve when starting the engine, the adjustment for decompression must be carried out first in order to provide an accurate valve clearance inspection.

Valve clearance inspection on engines with common, screw-type adjusters is measured by inserting a feeler gauge directly between the end of valve stem and the adjusting screw.

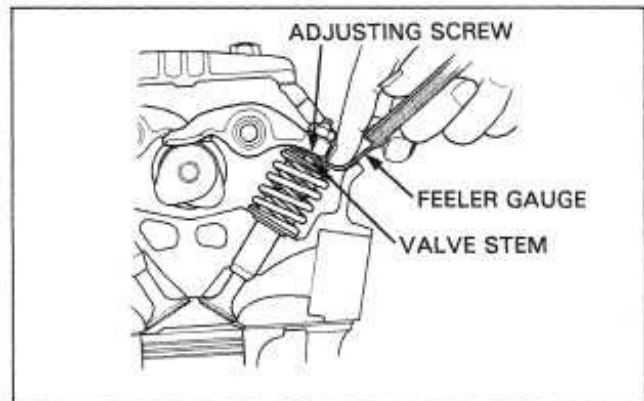

In the case of one-sided ball-joint type engines, the clearance is measured by inserting the feeler gauge between the rocker arm and the cam.

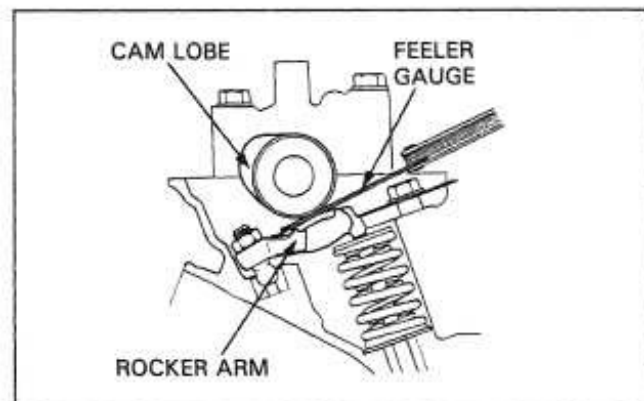

In the case of valve lifters in direct push-type engines, the clearance between the cam lobe and lifter or shim is measured with a feeler gauge.

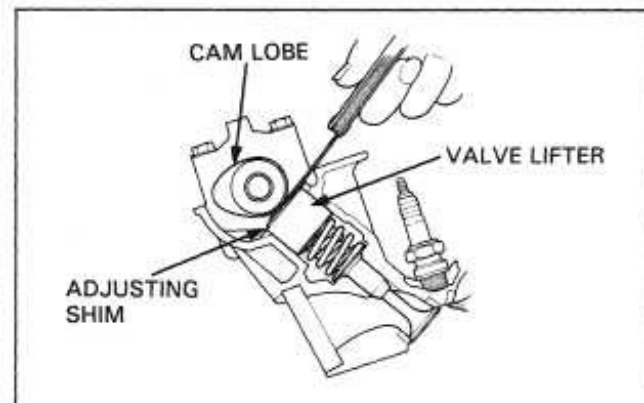

If adjustment is needed, loosen the lock nut and the adjusting screw and insert the proper dimension feeler gauge. Proper intake and exhaust valve clearance specifications are given in the Model Specific manual.

Turn the adjusting screw and adjust the clearance until the inserted feeler gauge can only be pulled out with a little difficulty.

Leaving the feeler gauge inserted, and being careful not to turn the adjusting screw, tighten the lock nut to the designated torque.

CAUTION

- An improperly tightened lock nut may loosen and cause engine damage.

Be sure to use any special tools specified for valve adjustment.

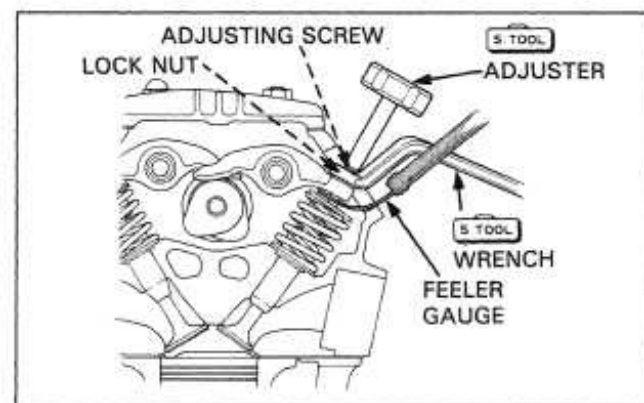

When the lock nut is tightened, the clearance may change. So be sure to recheck the clearance after tightening the locknut.

Adjustment is properly carried out only when the feeler gauge can be pulled out with a little difficulty. If tension on feeler gauge is too great or too little, readjust.

In the case of valve lifters in direct-push-type engines, change the shim to adjust the valve clearance. Refer to the Model Specific manual for the appropriate adjustment method.

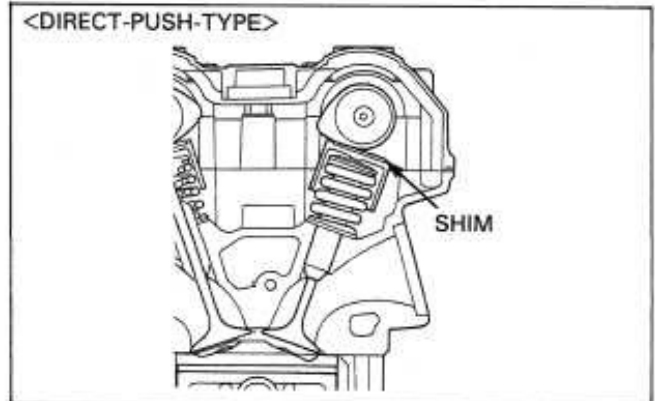

ENGINE OIL

NOTE

- Do not screw in the oil cap/level gauge when checking oil level.
- The oil level cannot be correctly measured if the motorcycle is not supported perfectly upright on a level surface.
- As the oil is gradually consumed, it is necessary to periodically check the oil level and replenish the oil volume to its proper level.
- If the oil level is too high, overall engine performance and the actuation of the clutch may be effected. Too little oil may cause engine overheating as well as premature wear to various parts.
- If a different brand or grade of oil or low quality oil is mixed when adding oil, the lubricating function deteriorates.
- Check the oil level only after starting the engine and allowing the oil to circulate through the engine thoroughly. It is especially important to run the engine before checking the oil level on a dry sump engine, due to the comparatively large volume of oil.

4-stroke, Wet Sump Engines:

Start the engine and let it idle for a few minutes.

Stop the engine, remove the oil level gauge and wipe the oil from the gauge with a clean cloth.

Two or three minutes after stopping the engine; with the motorcycle in an upright position, insert the level gauge into the engine without screwing it in.

The engine contains a sufficient amount of oil if the level is between the upper and lower lines on the gauge.

If the oil level is near or below the lower line, add the recommended engine oil up to the upper line.

Refer to the Model Specific manual for the recommended oil.

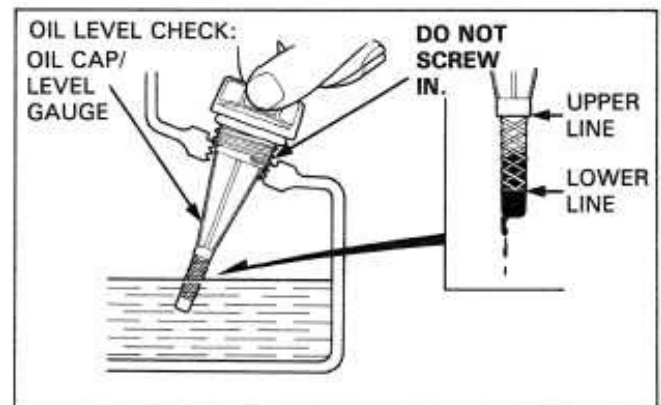

MAINTENANCE

4-stroke, Dry Sump Engines:

For more information refer to page 4-4.

For dry sump oil systems it is very important to follow the checking procedure exactly, so the oil flow is stabilized. Otherwise, it might seem like there is too much, or not enough oil.

Start the engine and allow the engine oil to warm up thoroughly.

NOTE

- Do not snap the throttle or the oil level reading will be inaccurate.

Allow the engine to idle for about 3 minutes and stop the engine. Remove the oil level gauge immediately and wipe it clean. With the motorcycle in an upright position on a level surface, check the oil level by inserting the gauge into the oil tank without screwing it in.

The engine contains a sufficient amount of oil if the oil level is between the upper and lower lines on the gauge.

If the oil level is near or below the lower line, add the recommended engine oil up to the upper line.

See the Model Specific manual for the recommended oil.

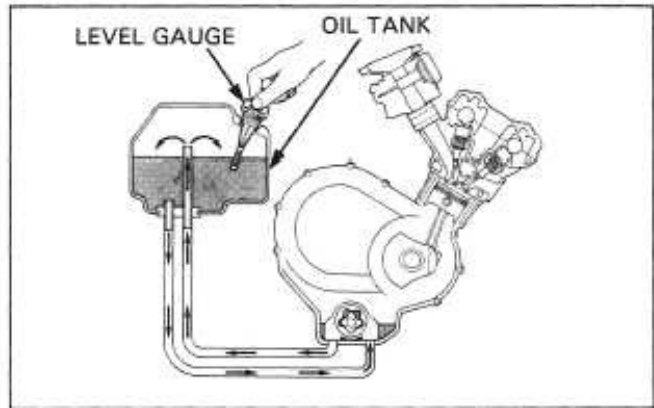

Leak Inspection:

Inspect to see that there is no oil leaking from any part of the engine, oil pipes, oil hoses, etc.

If any oil leaks are detected, perform the proper maintenance to correct the problem.

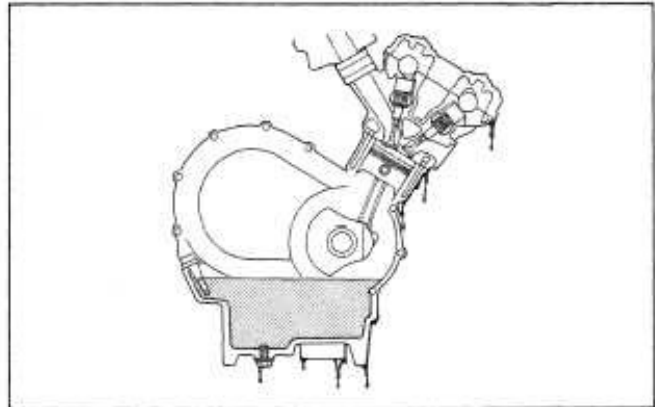

Oil Change:

In 4-stroke engines, sludge can build up, due in part to the gas which blows past the piston rings which contaminates the oil, causing a weakening of oil's performance. To alleviate this contamination problem, change the oil periodically.

Because many newly machined surfaces are moving against one another for the first time in new motorcycle engines, a noticeable amount of powdered metal circulates with the oil during this early stage of use.

Therefore, it is extremely important to change the engine oil and to replace the oil filter or clean the oil strainer screen at the first maintenance interval (after 1,000 km/600 miles) in order to prolong engine life.

See the Model Specific manual for oil change intervals.

NOTE

- Draining the engine oil while it is still warm is the most rapid and efficient method.

Remove either the oil level gauge or filler cap to allow rapid draining.
Remove the oil drain bolt at the bottom of the crankcase and drain the oil.

▲ WARNING

- Used engine oil may cause skin cancer if repeatedly left in contact with the skin for prolonged periods. Although this is unlikely unless you handle used oil on a daily basis, it is still advisable to thoroughly wash your hands with soap as soon as possible after handling used oil.

After the oil is completely drained, clean and install the drain bolt and sealing washer and tighten to the designated torque.

NOTE

- Replace the sealing washer if it is damaged.

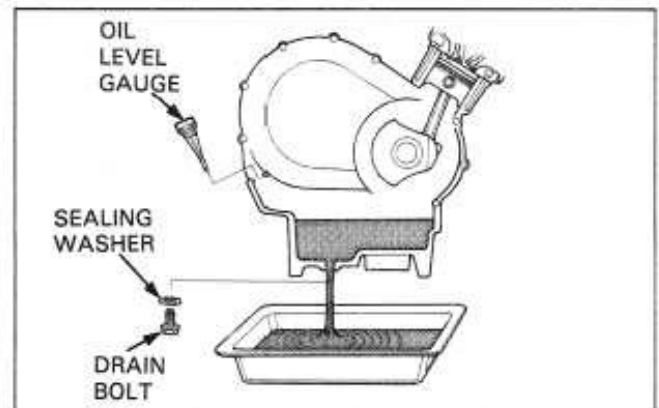

Pour the recommended engine oil into the engine through the oil level gauge/filler hole. The oil filler cap is separate from the oil level gauge on some engines.

Pour in the oil, periodically checking with the level gauge until the upper line on the gauge is reached.
Install and tighten the level gauge and/or filler cap after replenishing.

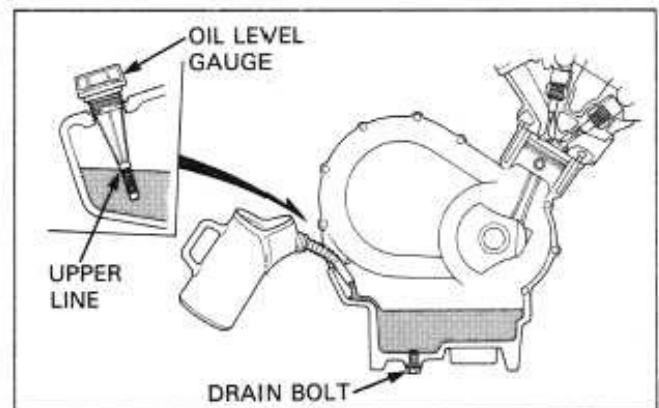

ENGINE OIL FILTER

Small dust particles and metal dust which do not filter through the net-type oil strainer screen are trapped by the paper oil filter. When the filter is clogged, the oil flow is reduced and contaminants may reach various parts of engine by way of the relief passage, causing premature wear and possible damage.

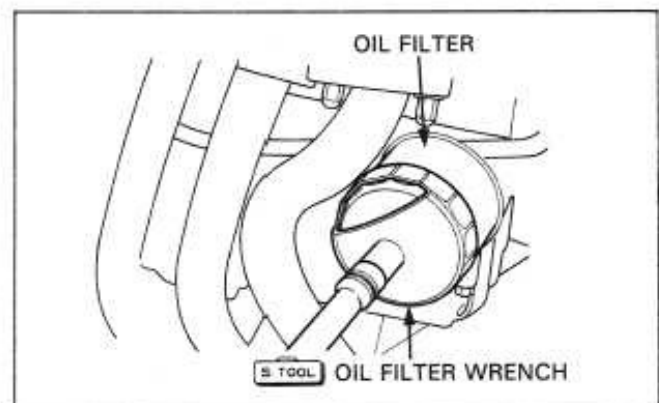

MAINTENANCE

Cartridge-Type Paper Filter

Cartridge-type oil filters are removed using a filter wrench.

▲ WARNING

- Engine and exhaust system parts become very hot and remain hot for some time after the engine is run. Wear insulated gloves or wait until the engine and exhaust system have cooled before handling these parts.

Clean the filter area of the engine with a clean cloth.

Spread engine oil thinly over the O-ring of the new filter and attach the filter to the engine.

Tighten the oil filter with the proper filter wrench.

5 TOOL

Oil Filter Wrench

(For small-type cartridge)

07HAA-PJ70100

(For large-type cartridge)

07912-6110001

Torque:

Small-type cartridge: 10 N·m(1.0 kg-m, 7 ft-lb)

Small-type cartridge with scale: 26 N·m(2.6 kg-m, 19 ft-lb)

Large-type cartridge: 18 N·m(1.8 kg-m, 13 ft-lb)

Small-type cartridge with scale can be tightened by the following procedure.

Install the oil filter and fully hand-tighten.

Tighten the oil filter using a filter wrench to rotate 1/12 turn.

NOTE

- Tighten 1/12 turn along the oil filter marker line.

Confirm that there is no oil leakage by starting the engine after the engine oil has been set at its proper level.

Run the engine for about a minute, then stop it and inspect carefully for leaks.

Element-Type Paper Filter

Remove the oil filter cover and replace the filter element.

Reinstall the cover with a new O-ring.

NOTE

- Install the element with the rubber seal side facing out, making sure that the spring is installed between the element and crankcase.
- If the element is installed incorrectly, it will reduce oil flow.
- Replace the O-ring on the filter cover with a new one.

Replenish the engine oil with the proper type and viscosity, and to the proper level. Always run the engine and check for oil leaks and verify the oil level after an oil or oil and filter change.

ENGINE OIL FILTER SCREEN

Check to see if there is any dirt or debris on the oil filter screen which might hinder the flow of oil. Remove and clean the screen in solvent if any deposits are found on the screen. Refer to the Model Specific manual for oil filter screen removal, cleaning and installation procedures for specific models.

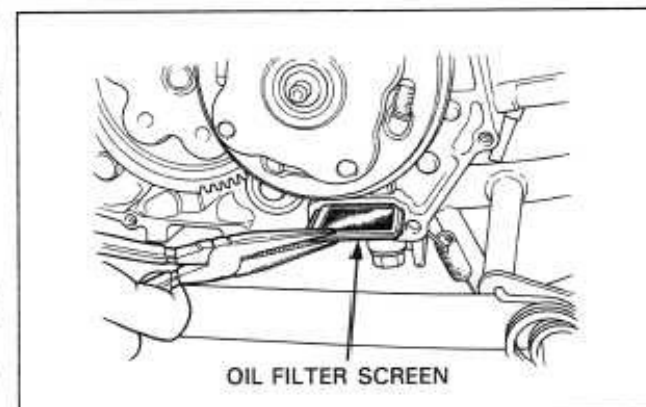
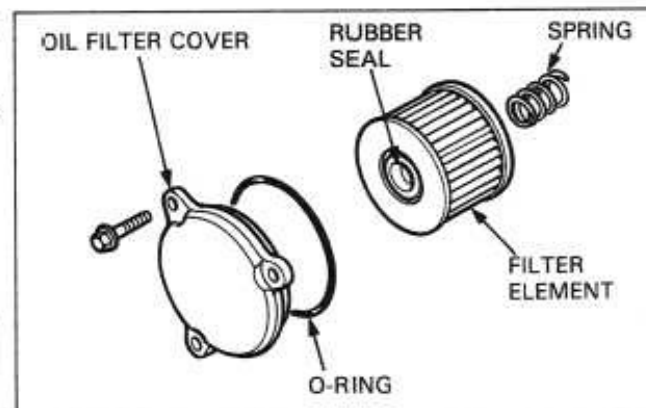
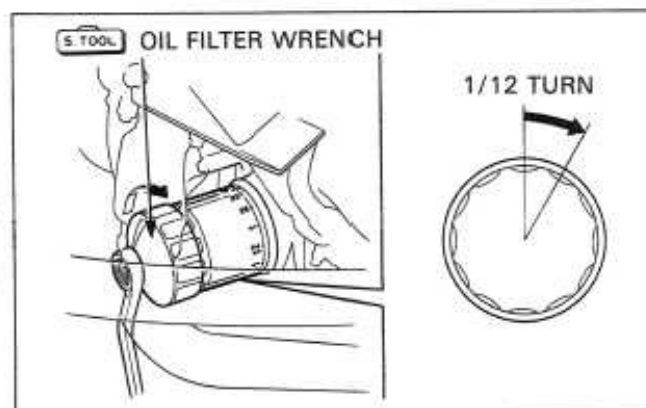
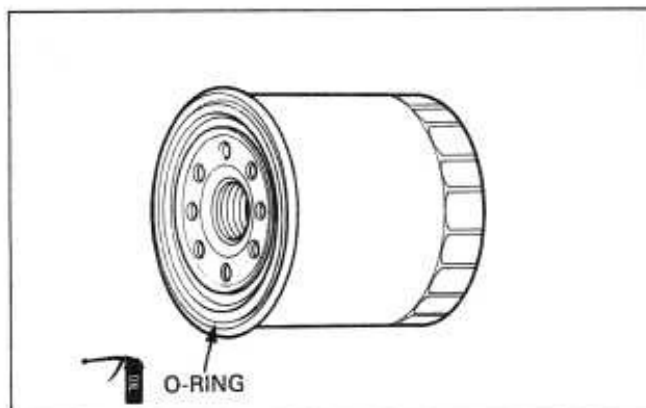

DECARBONIZING (2-stroke engine)

Carbon accumulation occurs more rapidly in 2-stroke engines than 4-stroke engines because 2-stroke engines burn engine oil. If the build-up of carbon is not removed periodically, the carbon accumulation increases to an excessive amount, causing hot spots on the cylinder head and piston crown. This may cause knocking due to preignition and may cause poor engine performance. Accumulated carbon in the exhaust port hinders the flow of the exhaust, causing a drop in power output. Therefore, removal of accumulated carbon should be performed according to the maintenance schedule in the Model Specific manual.

CAUTION

- When removing carbon, be careful not to damage the combustion chamber, piston and cylinder.

Take off the cylinder head and remove the carbon from the piston crown when the piston is in the top dead center position.

Remove carbon from the combustion chamber area of the cylinder head.

Take off the cylinder and remove accumulated carbon from the walls of the exhaust port.

Remove any remaining carbon within the cylinder.

In liquid-cooled engines, be sure to remove carbon particles that may have fallen into the coolant jackets around the cylinder by blowing them out with compressed air.

Refer to the Model Specific manual for the proper procedures for cylinder and cylinder head removal and installation.

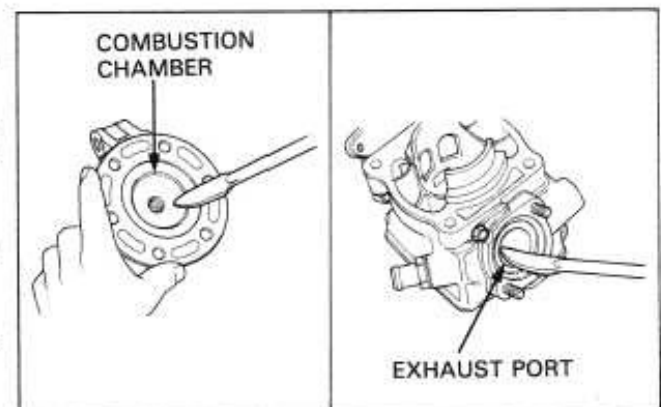
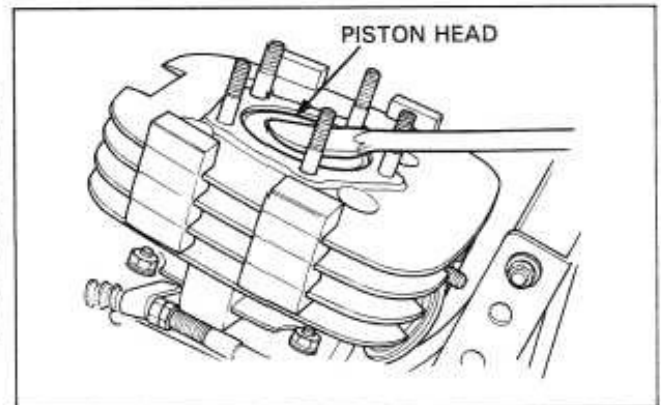

CARBURETOR SYNCHRONIZATION

NOTE

- Carburetor synchronization adjustment is required to adjust the throttle valve opening, and to synchronize the vacuum in each carburetor's intake port, whenever 2 or more carburetors are reassembled.
- Synchronize the carburetors with the engine at normal operating temperature, the transmission in neutral and the motorcycle on its center stand.
- Carburetor numbers match the cylinder number.

Remove the plugs from each cylinder head port and install the vacuum gauge adapters.

If the motorcycle is equipped with an automatic fuel valve, disconnect the vacuum tube from the intake manifold of the carburetor, draw vacuum and pinch the tube with a clip as shown.

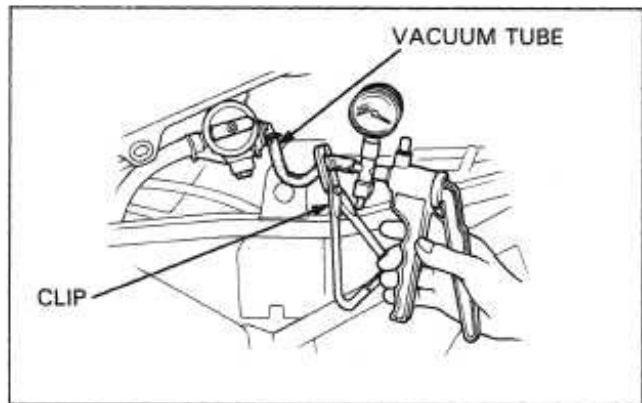
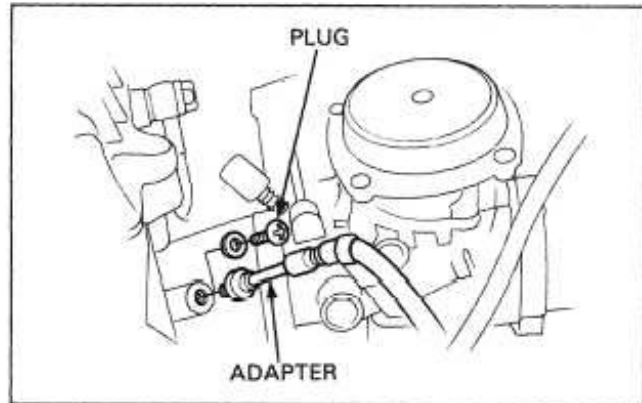

Connect the vacuum gauge.

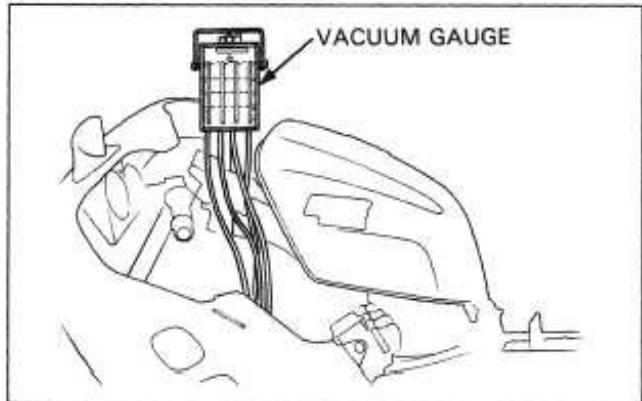

1. Adjust the idle rpm to the specified idle speed. (Refer to the Model Specific manual for the specification.)
2. Turn the synchronization adjusting screw so that the difference between the vacuum in the base carburetor's intake port and the vacuum in the other carburetor's intake port is below the specification. (Refer to the Model Specific manual for base carburetor, location of each synchronization adjusting screw and difference in vacuum between the carburetors.)
3. Be sure that the synchronization is stable by snapping the throttle grip several times.
4. Repeat steps 1 through 3 for each carburetor.
5. Snap the throttle grip several times and recheck the idle speed and differences in vacuum between each carburetor.

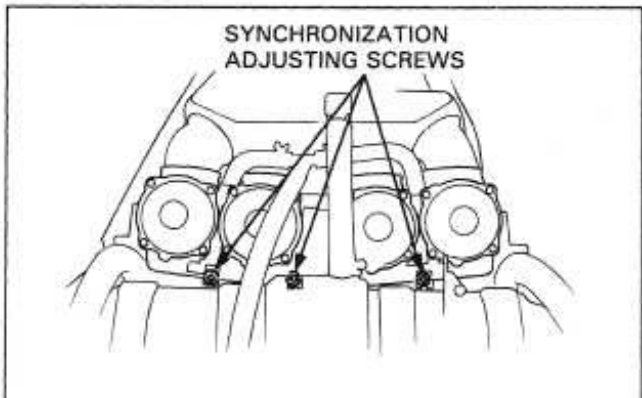

CARBURETOR IDLE SPEED

Check for any unusual noise while the engine is idling. If noise is detected, investigate with a stethoscope to locate the source. Carry out the appropriate maintenance inspection, depending on results of noise investigation.

Check to see that the engine speed increases smoothly from idle. Check the idle speed and adjust if necessary by turning the throttle stop screw.

NOTE

- Check and adjust after first warming up the engine. There are differences in idle speed between hot and cold engines.
- Place the vehicle on the center stand or support upright on level ground when checking and adjusting the idle speed. If the vehicle is tilted, there will be fluctuations in fuel flow from the carburetor which prevents an accurate determination of the idle speed.

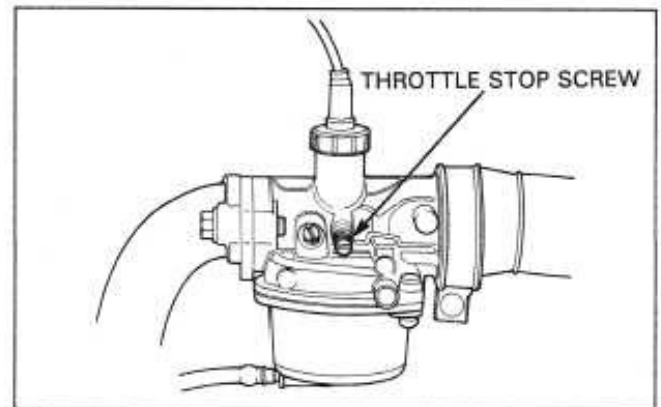

RADIATOR COOLANT

⚠ WARNING

- Wait until the engine is cool before removing the radiator cap. Removing the cap while the engine is hot and the coolant is under pressure may cause serious scalding.
- Radiator coolant is poisonous. Take care to avoid getting coolant in your eyes, on your skin, or on your clothes.
- If coolant gets in your eyes, flush repeatedly with water and contact a doctor immediately.
- If coolant is accidentally swallowed, induce vomiting and contact a doctor immediately.
- KEEP OUT OF REACH OF CHILDREN.

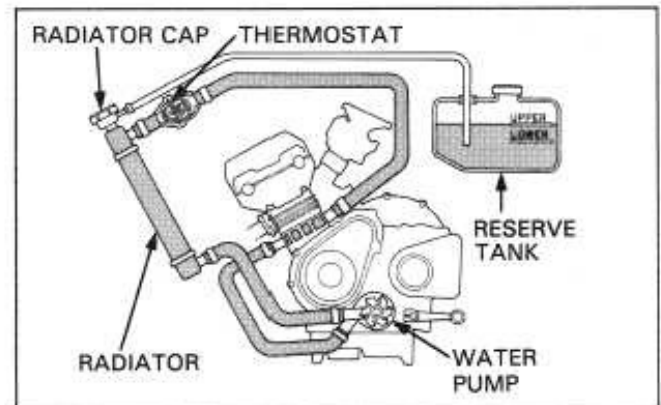

Coolant evaporates naturally, so check it regularly.

Coolant is both an antifreeze and an anti-rust agent.

CAUTION

- Be sure to use the proper mixture of antifreeze and distilled water to protect the engine.
- Use distilled water. Tap water may cause the engine to rust or corrode.

MAINTENANCE

LEVEL CHECK

Always check the coolant level with the motorcycle in a vertical position on a flat, level surface.

Always check the coolant level at the reserve tank (not the radiator).

Check to see if the coolant level in the reserve tank is somewhere between the upper and lower lines.

If the level is somewhere between the upper and lower lines or below the lower line, add a 50/50 mixture of antifreeze and distilled water to the upper line. (See Coolant Mixture Preparation page 5-6)

Check to see if there are any coolant leaks when the liquid level decreases very rapidly.

If the reserve tank becomes completely empty, there is a possibility of the air getting into the cooling system. So, be sure to remove all air from the cooling system as described on page 5-7.

NOTE

- The effectiveness of coolant decreases with the accumulation of rust or if there is a change in the mixing proportion during usage. Therefore, for best performance, change the coolant regularly. (See page 5-6)

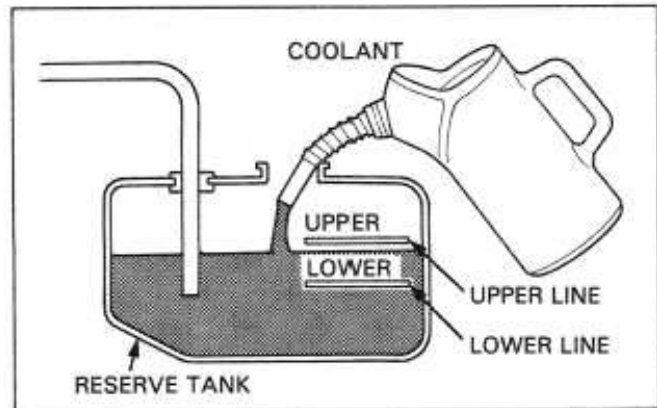

COOLING SYSTEM

▲ WARNING

- To prevent injury, keep your hands and clothing away from the cooling fan. It may start automatically, without warning.

Check the radiator air passages for clogging or damage, straighten bent fins with a small, flat blade screwdriver and remove insects, mud or other obstructions with compressed air or low water pressure. If 1/3 or more of the fins are crushed or twisted, the fins should be repaired using a small flat blade screwdriver.

Remove the body panels and fuel tank, and check for any coolant leakage from water pump, water hoses, and hose joints.

Check for any deterioration or damage to the water hoses. A rubber hose deteriorates naturally over time due to heat and wear. If the hose deteriorates too much, it will rupture due to the pressure in the cooling system. Squeeze the hose and look for cracks.

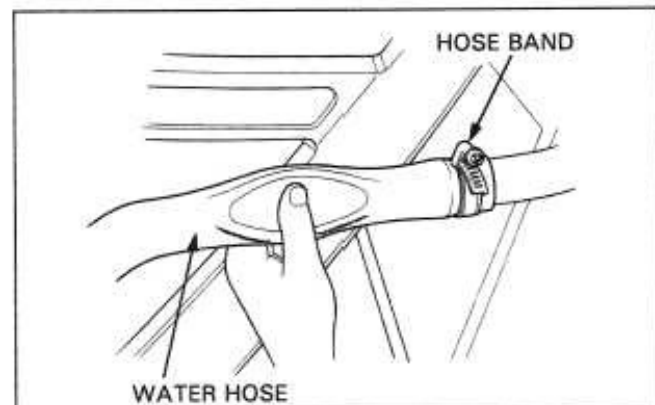
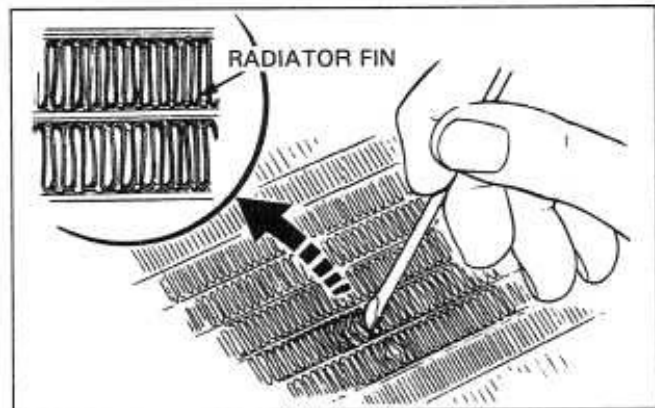

PULSE SECONDARY AIR SUPPLY (PAIR) SYSTEM

▲ WARNING

- To prevent injury, keep your hands and clothing away from the cooling fan. It may start automatically, without warning.

NOTE

- The pulse secondary air supply system introduces filtered air into the exhaust gases in the exhaust port. The secondary air is drawn into the exhaust port whenever there is a negative pressure pulse in the exhaust system. This charged secondary air promotes burning of the unburned exhaust gases and changes a considerable amount of hydrocarbons and carbon monoxide into relatively harmless carbon dioxide and water.

Check the air supply tubes between the valve and exhaust ports for deterioration, damage, or loose connections. Make sure the tubes are not kinked, pinched, or cracked.

NOTE

- If the tubes show any signs of heat damage, inspect the reed valve in the system for damage.

Check the vacuum hose between the intake pipe and valve for deterioration, damage or a loose connection. Make sure the hose is not kinked, pinched, or cracked.

Refer to the vacuum hose routing diagram label for hose connections.



EVAPORATIVE EMISSION CONTROL SYSTEM

▲ WARNING

- To prevent injury, keep your hands and clothing away from the cooling fan. It may start automatically, without warning.

NOTE

- Fuel vapor from the fuel tank is directed into the evaporative emission canister while the engine is stopped. When the engine is running, the evaporative emission purge control valve opens and fuel vapor in the evaporative emission canister is drawn into the engine through the carburetor. The tubes deteriorate naturally due to wear and time. Check the condition of these tubes at the intervals specified in the Model Specific manual.

Check the hoses between the fuel tank, evaporative emission canister, evaporative emission purge control valve, evaporative emission carburetor air vent control valve and carburetors for deterioration, damage or loose connections.

Check the evaporative emission canister for cracks or other damage.

Refer to the vacuum routing diagram label for hose connections.

MAINTENANCE

TRANSMISSION OIL (2-stroke engine)

Check for oil leakage over all sections of the transmission.
Check the oil level.

Excessive oil leakage necessitates disassembly.

With the engine stopped, remove the oil check bolt and make sure that the oil level is up to the lower edge of the bolt hole. Refill to the lower edge of the oil level check bolt hole with the recommended oil if the level is low.

NOTE

- Oil level checks should be carried out on level ground with the vehicle on the center stand or while in an upright position.

In scooters, check for leakage and oil level of the final reduction gear case in the same way as for the engine.

Remove the level hole cap from the gear case and check whether the oil level comes up to lower edge of the hole. If the level is low, refill to the lower edge of the hole with the recommended oil.

NOTE

- Oil level checks should be carried out on level ground with the vehicle on the center stand or while in an upright position.

Transmission oil change

Two stroke engine transmission lubrication is achieved by the spray of transmission oil within the sealed crankcase. Compared to 4 stroke engines, there is little oil degradation, and the period for change is longer.

Consult the Model Specific manual for the proper oil change interval.

⚠ WARNING

- Used engine oil may cause skin cancer if repeatedly left in contact with the skin for prolonged periods. Although this is unlikely unless you handle used oil on a daily basis, it is still advisable to wash your hands with soap as soon as possible after handling used oil.

NOTE

- Oil is more easily drained when the engine is warm.

Remove the oil filler cap.

Remove the drain bolt located at the bottom of the crankcase and drain the oil.

When all the oil is drained, clean the drain bolt with its sealing washer and tighten to the designated torque.

NOTE

- Be sure to replace the sealing washer if it is damaged.

Remove the oil check bolt, and refill to the prescribed level with the recommended oil. Replace the check bolt or cap.

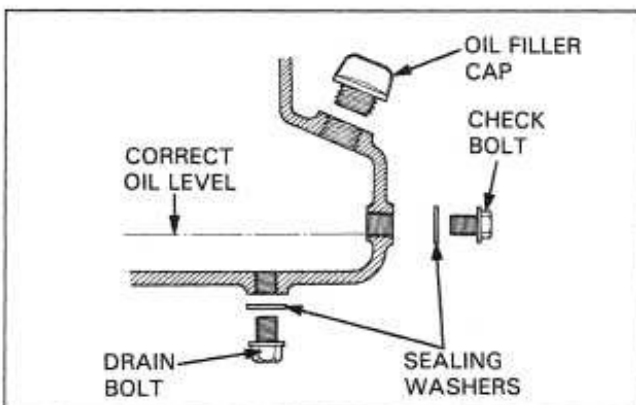
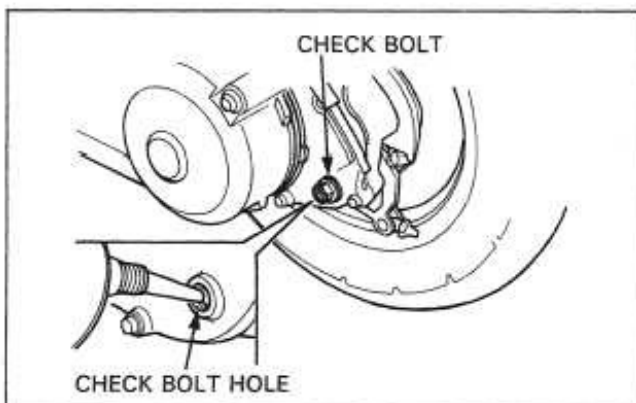
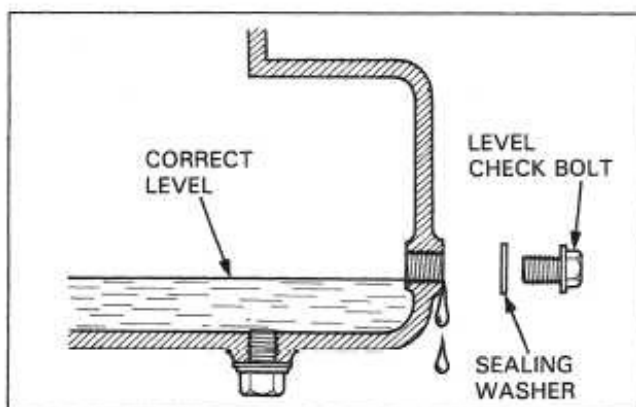

DRIVE CHAIN

ADJUSTMENT

▲ WARNING

- Inspecting the drive chain while the engine is running can result in serious hand or finger injury.

When there is too little slack, a change in the distance between sprocket centers, due to suspension movement, results in excessive tension on the chain.

In this condition, the chain and transmission or crankcase may be damaged, and the large amount of friction adversely affects the running performance of the vehicle.

Too excessive slack in the chain leads to large oscillations when the vehicle is running. In this condition, the chain may come off the sprockets or damage parts it contacts.

With the vehicle in neutral, support on the center or side stand. (Some models need to be checked with the rear wheel raised. Refer to the Model Specific service manual for details). Check the slack in the chain at the midpoint between the two sprockets.

(On models with a chain tensioner, loosen the tensioner before checking).

Carry out the following procedure for adjustment;

Loosen the rear axle nut until the wheel can be moved.

Loosen the adjuster lock nut, turn the adjuster nut or bolt and adjust the play.

On snail cam types, rotate the adjuster plates.

A scale is included on the adjuster. Be sure that the reading on the scale is the same for both sides.

CAUTION

- If the adjustment value is not the same, the wheel is out of alignment and can cause excessive tire, sprocket and chain wear.

As the rear suspension moves through its travel, the distance between the drive and driven sprocket centers varies. Therefore, it is important to adjust the chain so that it has at least the minimum amount of acceptable slack when the sprockets are farthest apart—or when the center of the drive sprocket, swingarm pivot bolt and the rear axle are in alignment. The Model Specific manual provides a proper dimension for each model based on this minimum slack and maximum distance position, but it is measured in a much more convenient suspension position.

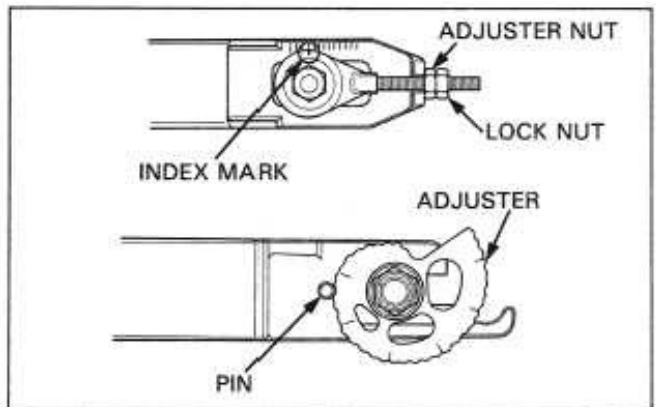
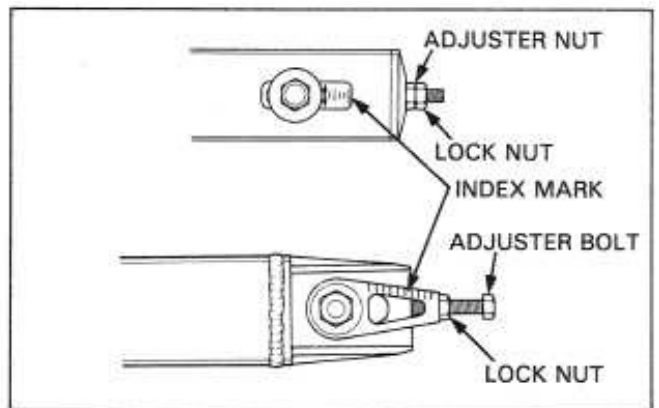
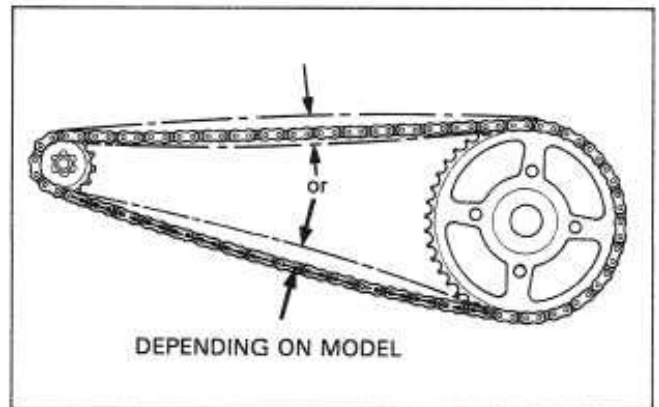

MAINTENANCE

After adjustment, retighten the axle nut to the specified torque.

NOTE

- Pulling the lower chain row firmly up toward the swing-arm when tightening the axle nut helps ensure that the adjusters on both sides are seated against their stops and that the axle is in proper alignment. Always check to be sure both sides are adjusted to the same marks on the adjustment scales.

Re-check the chain play.

Tighten the adjusters and lock nuts.

Adjust the rear brake pedal play. (This step can be omitted in the case of disc brakes).

Adjust the rear brake light switch actuation point (on cable operated rear drum brake models).

If, after adjustment, the adjuster's alignment mark is within the red zone of the chain wear indicator label, replace the drive chain and both sprockets (Only for vehicles with an indicator label affixed).

NOTE

- Always replace both sprockets when replacing the drive chain for optimum wear characteristics.

After replacing and adjusting the drive chain, attach a wear indicator label so that the alignment mark is at the start of the green zone.

On models without drive chain wear indicators measure the length between the chain's pins (see next page).

ADJUSTMENT OF PRO-ARM TYPE

Loosen the bearing holder flange bolt.

Rotate the bearing holder using the pin-spanner in the vehicle's tool set to adjust the drive chain play.

After adjustment, retighten the bearing holder flange bolt to the specified torque.

If, after adjustment, the driven sprocket outer circle is within the red zone of the chain wear indicator label, replace the drive chain (only for vehicles with an indicator label affixed.) After replacing and adjustment of the drive chain, attach a wear indicator label so that the driven sprocket outer circle is at the start of the green zone (the other side of the red zone).

NOTE

- Always replace both sprockets when replacing the drive chain for optimum wear characteristics.

On models without drive chain wear indicators measure the length between the chain's pins (see next page).

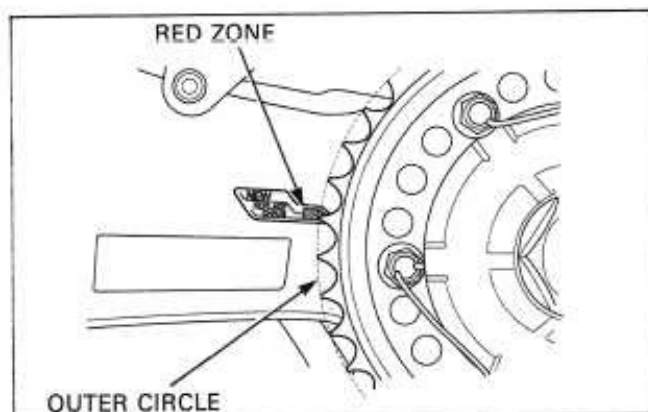
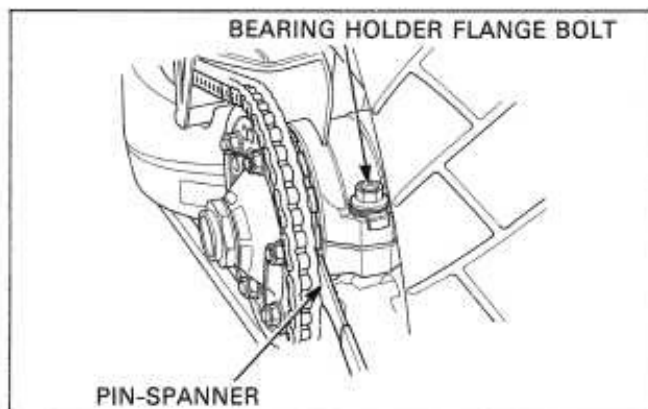
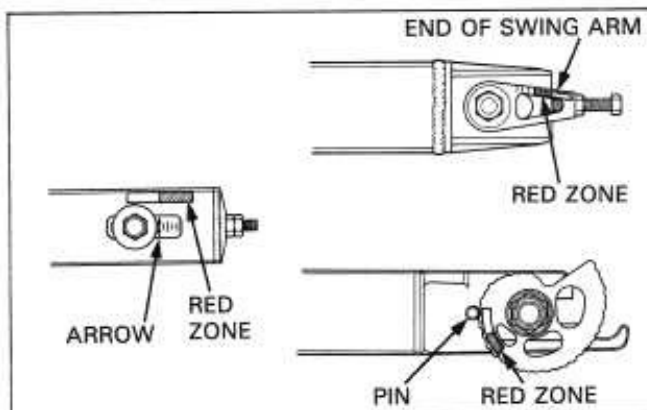
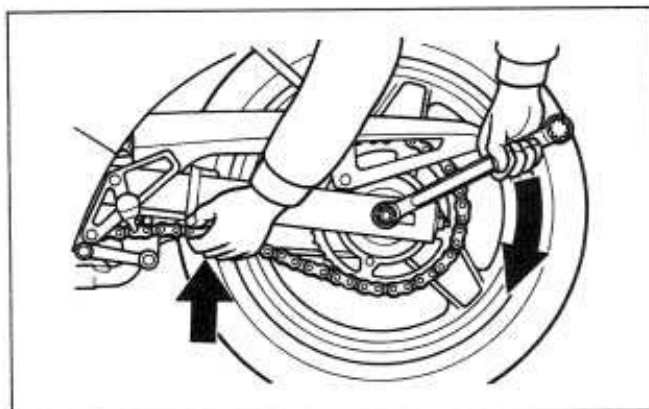

INSPECTION OF CHAIN REPLACEMENT PERIOD
(Only for the models without a drive chain wear indicators)

Remove the drive chain, measure the chain length (41 pins, 40 links) and replace the chain if the prescribed limits specified in the following table are exceeded.

Some endless chains require removal of the swingarm for drive chain replacement.

Others use a special tool to remove and install the master link.

The outer plate of this type of master link is secured by expanding the ends of the pins with the special tool.

Position the master link clip so that its open end is opposite the normal rotation of the chain. This prevents the clip being knocked off through contact with the chain guide or passing objects. Check that the clip is fully seated.

CAUTION

- **Improper positioning of the master link may cause the drive chain to come apart and possibly damage the crankcase, rear wheel or exhaust.**

41 PINS (40 LINKS)

CHAIN CLIP

ROTATING DIRECTION

Drive Chain Length (41 pins/40 links)			Unit: mm (in)
CHAIN SIZE CODE	PITCH	STANDARD	SERVICE LIMIT
415/420/428	12.70 (0.500)	508 (20.0)	511 (20.1) <518 (20.4)>
520/525/50	15.875 (0.625)	635 (25.0)	638 (25.1) <648 (25.5)>
630	19.05 (0.750)	762 (30.0)	766 (30.2) <777 (30.6)>

< >: Without o-ring chain

Check that each chain link pivots freely on the pins. Where binding is light, apply a little cleaning oil or paraffine making sure that it penetrates. When the stiffness has been removed, lubricate the chain. On chains with O-ring, quickly wipe off the cleaning fluid or paraffin oil, and thoroughly dry the chain. Replace the chain if stiffness of the chain cannot be alleviated, the movement of the links is not smooth, or there is damage to the link plates or rollers. Master links with O-rings have 4 O-rings fitted between rollers and master link plates. Install the O-rings as shown in the illustration to the right and fit the chain clip to the pins. Be sure there is no gap between the master link plate and the clip.

Cleaning, Inspection and lubrication

O-ring Chains

O-ring drive chains are equipped with small O-rings between the link plates that retain grease within the pivot areas and improve its service life. The O-rings in this chain can be damaged by steam cleaning, high pressure washers and certain solvents. Damaged O-rings or contaminated grease in the pivot areas will shorten drive chain service life.

Clean the chain with non-flammable or high flash point solvent and wipe it dry. Be sure the chain has dried completely before lubricating.

Inspect the drive chain for possible wear or damage. Replace any chain that has damaged rollers, loose fitting links, or otherwise appears unserviceable. Installing a new chain on badly worn sprockets will cause the new chain to wear quickly. Inspect and replace sprockets as necessary.

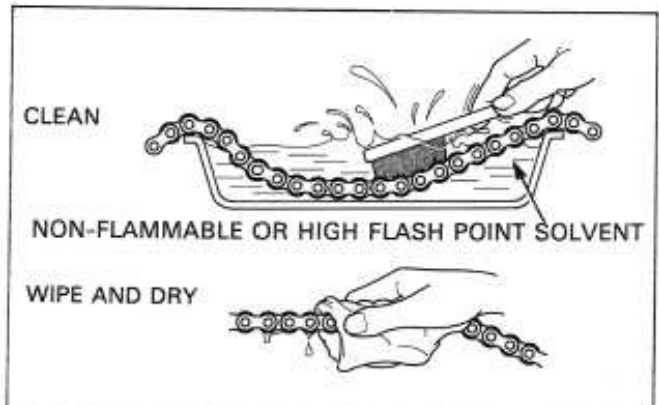
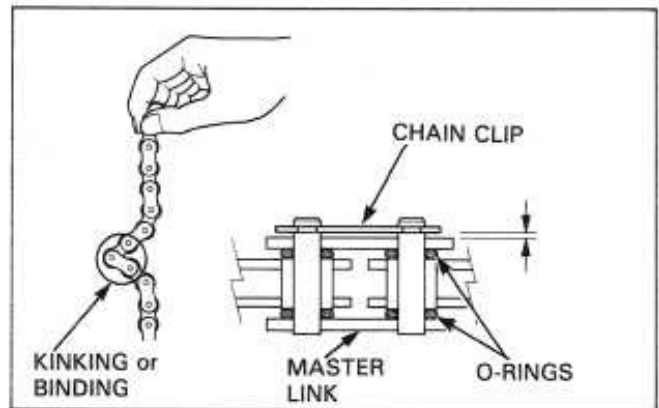

MAINTENANCE

Lubricate the chain with Pro Honda Chain Lube or equivalent chain lubricant designed specifically for use on O-ring chains. Some commercial chain lubricants may contain solvents which could damage the O-rings. Wipe off the excess chain lube to prevent it from flinging off when in operation.

Non O-ring Chain

Clean the chain with non-flammable or high flash point solvent and wipe it dry. Be sure the chain has dried completely before lubricating.

Inspect the drive chain for possible wear or damage. Replace any chain that has damaged rollers, loose fitting links, or otherwise appears unserviceable. Installing a new chain on badly worn sprockets will cause the new chain to wear quickly. Inspect and replace sprockets as necessary.

Lubricate the chain with Pro Honda Chain Lube or equivalent chain lubricant designed specifically for motorcycle chains. Wipe off the excess chain lube to prevent it from flinging off when in operation.

Sprockets

Inspect the drive and driven sprocket teeth for wear or damage. Replace if necessary. Never use a new drive chain or worn sprockets. Both chain and sprockets must be in good condition, or the new replacement chain or sprockets will wear rapidly.

Check the attachment bolts or nuts on the drive and driven sprockets. If any are loose, torque them.

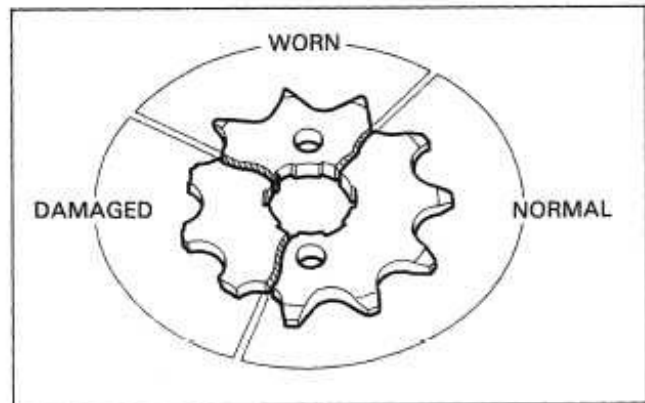
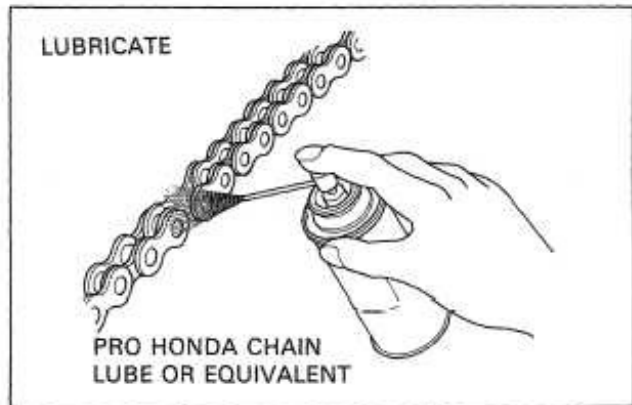

REPLACEMENT OF ENDLESS CHAIN

CAUTION

- Because of the drive chain is master link joint pin staking type (the ends of the pins are expanded with the special tool), the specified types of chain and special tool must be used to replace. Do not use clip type chains.

Loosen the drive chain.
Assemble the special tool.

S. TOOL

Drive chain cutter **07HMH-MR10102**
Link plate holder
(Refer to the Model Specific service manual.)

NOTE

- When using the special tool, follow the manufacturer's operating instructions.

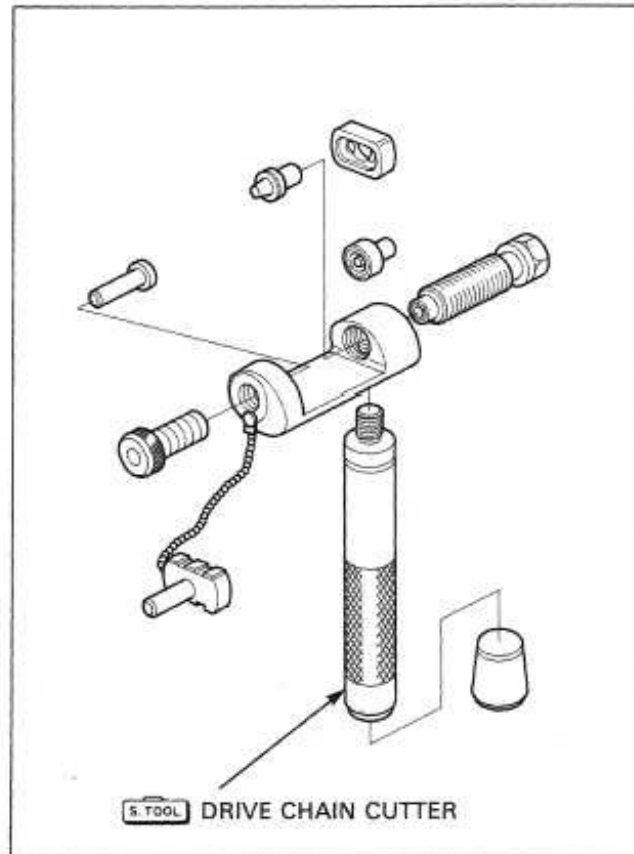

Locate the drive chain cutter on the staked part of the drive chain and cut the staked pins.

S TOOL

Drive chain cutter 07HMH-MR10102

Remove the drive chain.

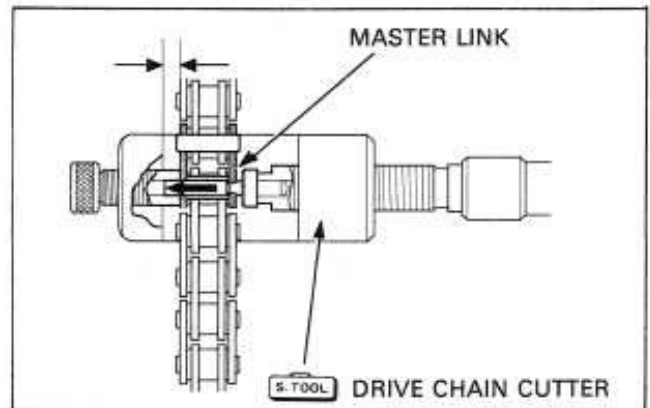

Remove the excess drive chain links from the new drive chain with the drive chain cutter.

Standard link: Refer to the Model Specific service manual.

Replacement chain: Refer to the Model Specific service manual.

NOTE

- One (1) link is indicated as the figure on the right.
- Include the master link when you count the drive chain links.

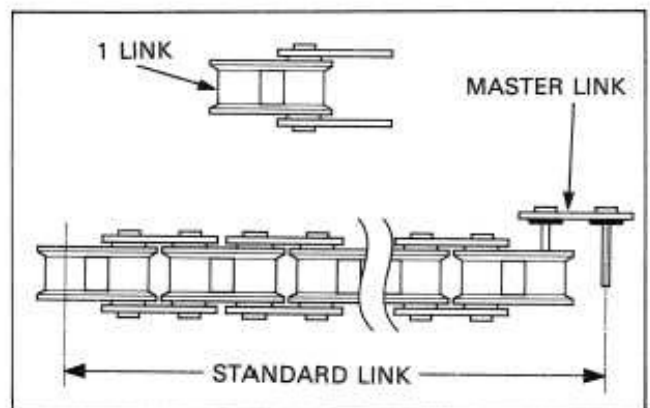

Install the new drive chain over the swingarm.

CAUTION

- Never reuse the old master link, master link plate and O-rings.

Install the O-rings onto the new master link, and insert the master link from the inside of the drive chain taking care to prevent squeezing.

Install the O-rings and the link plate with the drive chain cutter.

S TOOL

Drive chain cutter 07HMH-MR10102
Link plate holder
(Refer to the Model Specific service manual.)

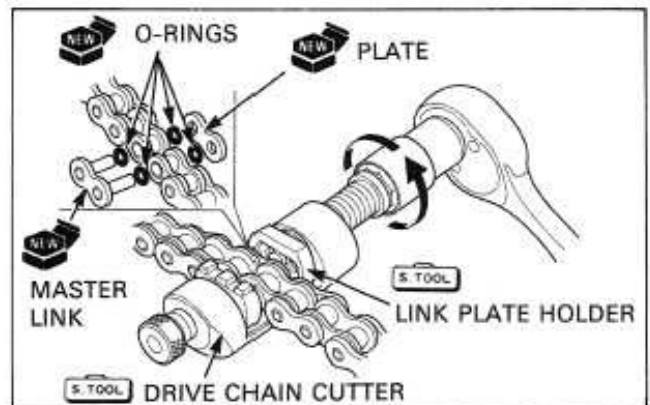

NOTE

- Install the link plate with the identification mark facing the outside.
- Take care to prevent squeezing of the O-rings.
- Do not remove initially applied grease from the link to lubricate.

Remove the special tool and check the master link pin length projected from the plate.

Standard length: Refer to the Model Specific service manual.

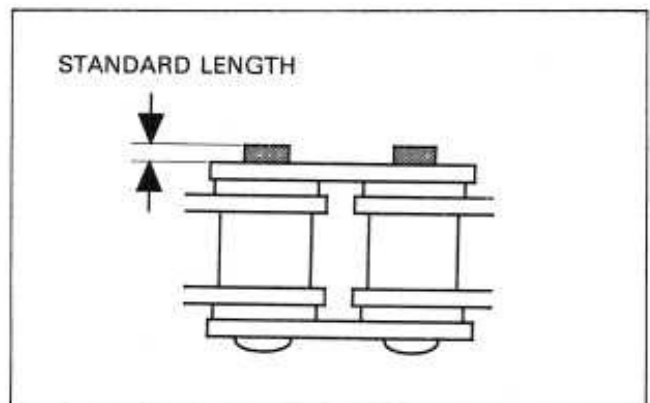

MAINTENANCE

Install the drive chain cutter and stake the ends of the master link pins.

S TOOL

Drive chain cutter

07HMH-MR10102

NOTE

- To prevent over staking, stake gradually checking the diameter of the staked area using a slide calipers.

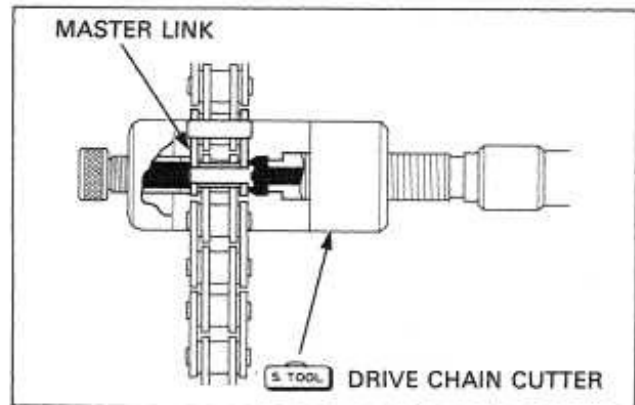

After staking, check the staked area of the master link using a slide calipers.

Diameter of the staked area: Refer to the Model Specific service manual.

NOTE

- When the measured staked area is over the prescribed value, restake using the new master link, plate and O-rings.
- When the measured staked area is below the prescribed value, reinstall the drive chain cutter and restake.

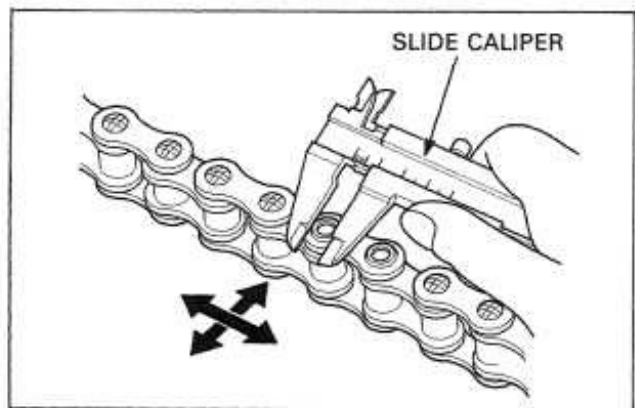

Check the staked area of the master link for cracks and the O-rings for damages.

If there is any cracking or damage, replace the master link, plate and O-rings.

Check that master link pivots freely on the pins.

If the movement is not smooth, restake using the new master link, plate and O-rings.

Adjust the drive chain play.

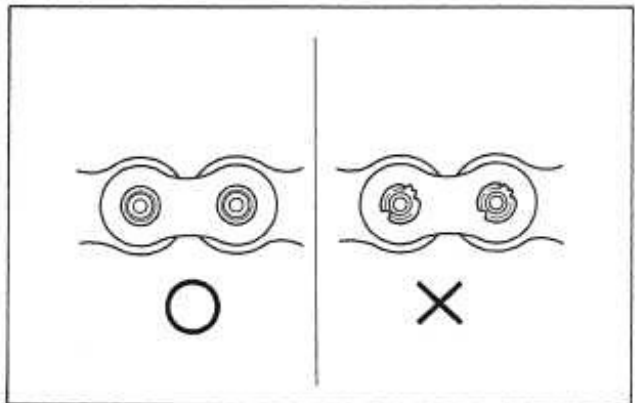

DRIVE CHAIN SLIDER, CHAIN GUIDE, GUIDE SLIDER AND ROLLERS

Together, the drive chain slider, chain guide, guide slider and rollers: all do their part to keep the chain running in its proper path, while preventing it from cutting into the swingarm, frame or other components.

Each of these components is made of a type of plastic that offers minimal friction and wear. Still, periodic inspection for wear or damage and replacement is necessary as these parts deteriorate.

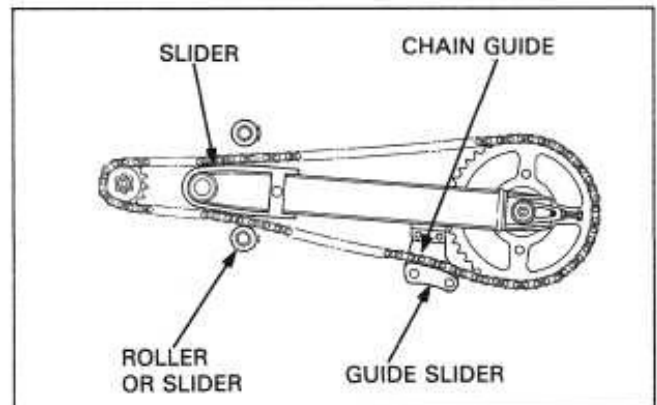

The chain slider, attached to the front of the swingarm near its pivot point, must be replaced when the depth of its wear grooves reaches a depth specified for each particular model. Failure to replace a worn slider will result in chain damage to the swingarm and damage to the chain.

Off-road and dual-purpose motorcycles are fitted with a chain guide that ensures that the chain is guided directly to rear sprocket. The guide itself should be checked for proper alignment as it can be bent through contact with passing objects, rocks or crash damage. Straighten or replace as necessary. A plastic guide slider centers the guide on the sprocket with minimal friction and prevents the chain from wearing the guide. A wear window is often provided to aid in determining a replacement time.

A lower chain roller, or a pair of upper and lower rollers are used to take up excess slack in the drive chain as the rear suspension compresses and extends to its furthest points. These rollers also help prevent the chain from cutting into other components on the motorcycle, like the airbox or exhaust on some motorcycles, when the suspension is near or fully compressed. These must also be periodically inspected for wear, damage and security of mounting.

DRIVE BELT

A drive belt is used on the Honda V-matic belt automatic transmission.

The belt must be checked periodically according to the maintenance schedule shown in the Model Specific manual.

A worn or damaged drive belt may cause a loss in scooter performance.

Remove the drive belt cover (see the Model Specific manual) and check the drive belt for wear, cracks or peeling of the cogs or plies; replace with a new one if necessary.

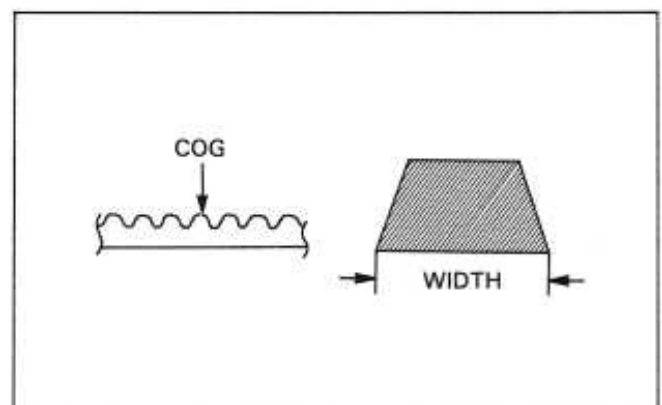

MAINTENANCE

BELT CASE AIR CLEANER

On scooters with a cleaner element in the air inlet to the drive belt case, remove the element and clean.

Wash the element in water and dry it thoroughly before reinstalling.

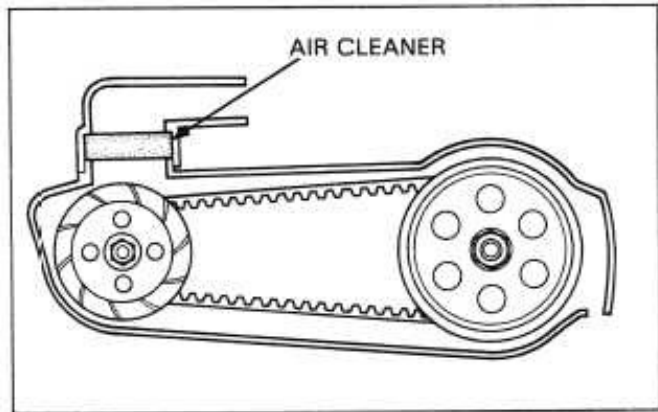

FINAL DRIVE OIL LEVEL

Check for leakage and proper oil level.

Remove the inspection/level hole cap from the gear case and check that the oil level is up to the lower edge of the hole. If the oil level is low, refill to the lower edge of the hole with the recommended oil.

NOTE

- Oil level checks should be carried out on level ground with the vehicle on the center stand.

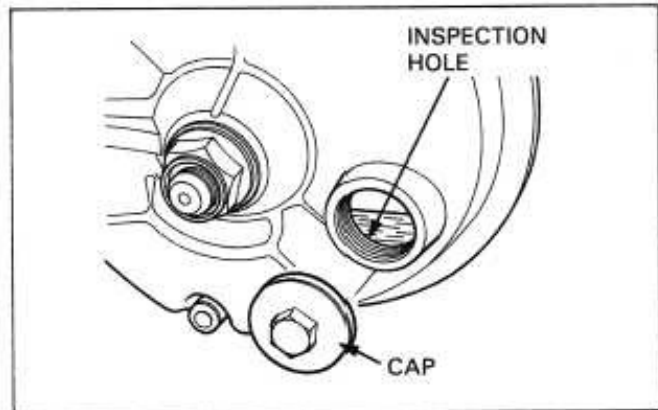

OIL CHANGE

Refer to the Model Specific service manual for information on the oil change interval.

Remove the level hole cap from the final gear case.

Remove the oil drain bolt from the lower portion of the gear case, slowly turn the rear wheel and drain the oil. When the oil is completely drained, clean the drain bolt, replace the sealing washer and tighten to the specified torque.

NOTE

- Replace the sealing washer if it is damaged.

Refill to the prescribed level with the recommended oil.

Coat the level hole cap O-ring with oil and replace the cap.

Tighten the cap to the specified torque.

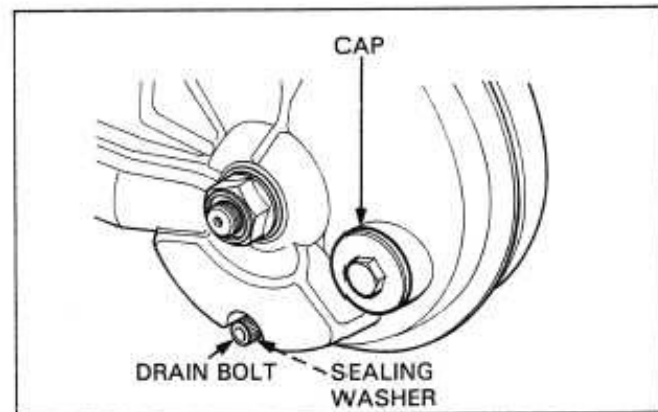

BATTERY

Fluid level

Battery fluid level checks are unnecessary on MF (Maintenance Free) batteries.

Open type batteries should be checked for fluid level.

⚠ WARNING

- Do not allow battery fluid (sulphuric acid) to come into contact with the skin, eyes or clothes as it will cause burning. If acid is spilled on you, be sure to wash off quickly with large amounts of water. If battery fluid enters the eyes, wash with water and consult a physician.

Check for cracks in the battery case.

If the battery's electrodes show accumulation of a white substance (sulphation) or heavy deposits are observed at the base of the battery, the battery should be replaced.

Check the level of each cell by the UPPER and LOWER level lines inscribed on the side of the battery.

If levels are approaching the LOWER level line, remove the battery, take off the filler caps and refill to the UPPER level with distilled water.

Check the battery capacity with a battery tester (page 22-11). If the battery tester is not available, check the gravity of the battery fluid (see below).

CAUTION

- Always refill batteries with distilled water. Tap water contains minerals that will shorten the life of the battery.
- Filling the battery above the UPPER level mark may cause spillage while riding and subsequent corrosion of vehicle parts.

After refilling, replace each of the filler caps firmly and re-install the battery.

Follow the instructions on the battery's CAUTION label. Make sure that the breather tube is correctly positioned, and not kinked, trapped or bent in such a way as to obstruct the passage of air.

CAUTION

- If the tube is blocked, the battery's internal pressure will not be relieved, the breather may come off, or the battery could crack as a result.

Specific gravity of fluid

Checks are unnecessary in the case of MF (Maintenance Free) batteries.

The specific gravity of the battery fluid should be checked on open type batteries.

Measure the specific gravity of each cell with a hydrometer.

Specific gravity of fluid at 20°C (68°F)

Fully charged condition 1.27 – 1.29

Low charge condition 1.23 and below

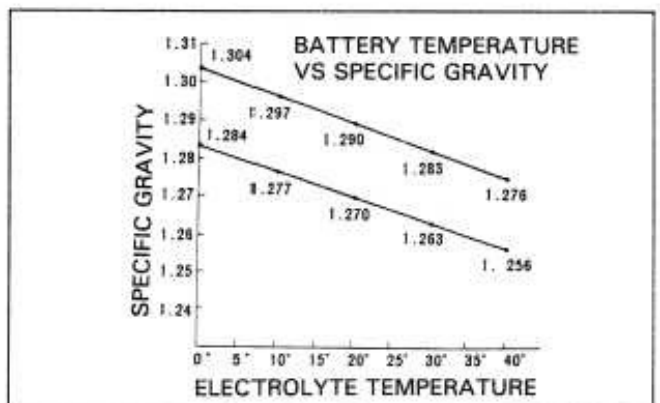
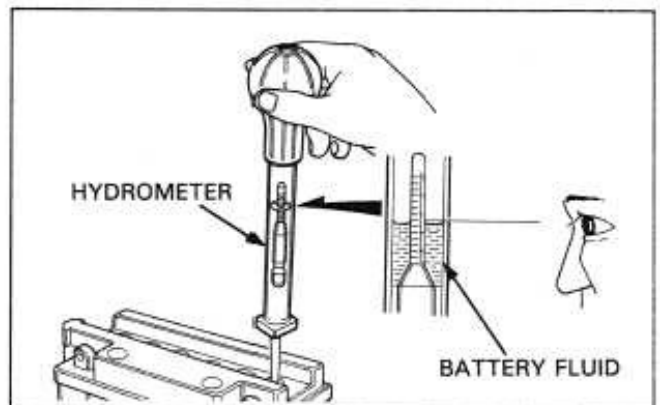
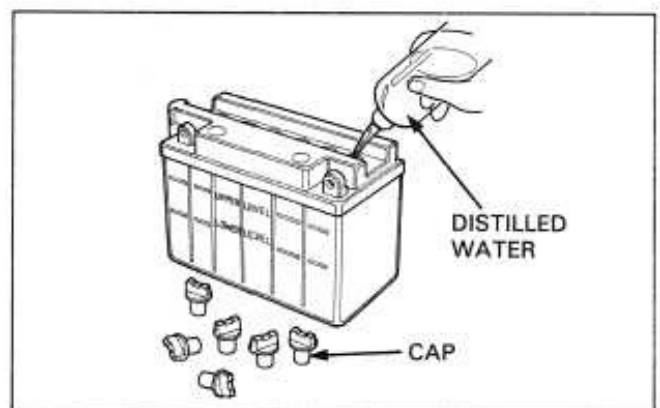
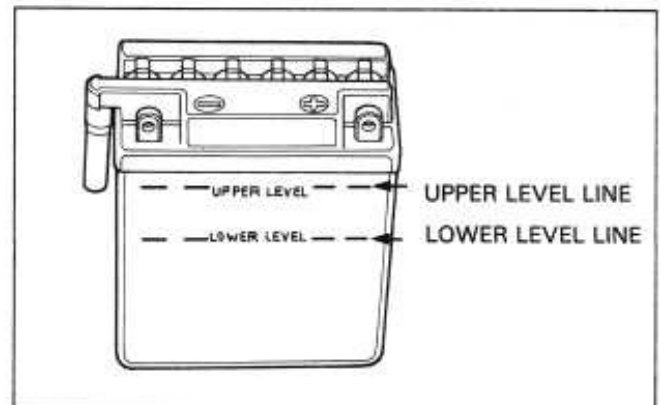

MAINTENANCE

NOTE

- If the difference in specific gravity between cells exceeds 0.01, re-charge the battery. If the difference in specific gravity is excessive, replace the battery.
- There is a change in specific gravity of approximately 0.007 per 10°C change in temperature. Be sure to consider this when taking measurements.
- Reading of the hydrometer's fluid level should be taken in the horizontal position.

Refer to section 22 for details of battery testing and charging.

Condition of terminal connections

Make sure that terminal connections are not loose. If corrosion is evident, remove the battery, wash rust with warm water and use a wire brush to remove completely.

Reconnect the battery and lightly coat the terminals with grease.

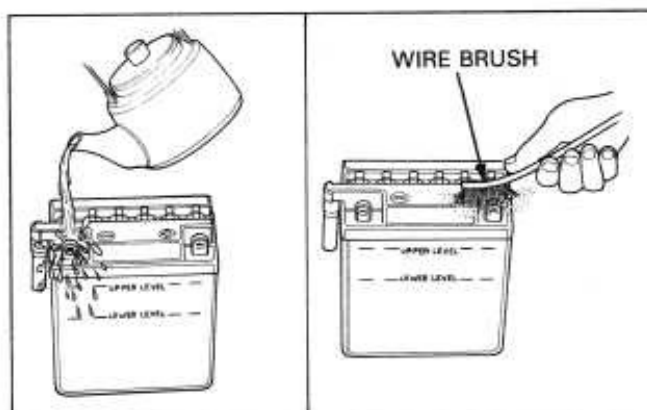

BRAKE FLUID

Firmly apply the brake and check for fluid leakage from the brake system. If there is any leakage of fluid from any part of the system, quickly replace the damaged parts.

Check for degradation and damage of the hoses, pipes and joints. Check for looseness of joints and clamps. Also make sure that hoses and pipes do not come into contact with mechanical parts when the fork is turned, or due to vibration when the vehicle is running.

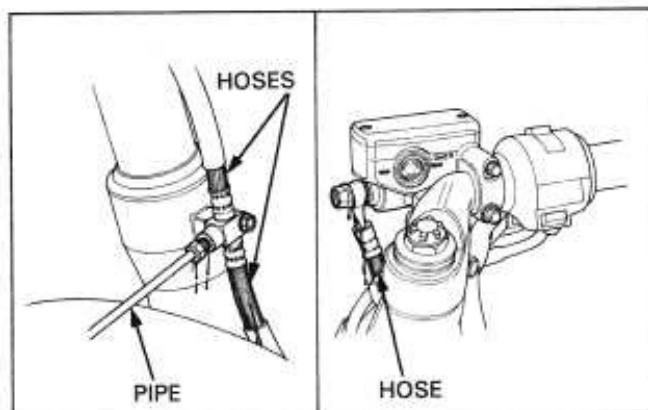

Before removing the reservoir cover, turn the handlebar until the reservoir is level.

Place a rag over painted, plastic or rubber parts whenever the system is serviced.

CAUTION

- Brake fluid will damage painted, plastic or rubber parts.

Refill with the recommended fluid.

▲ WARNING

- Mixing incompatible fluids can impair braking efficiency.
- Foreign materials can clog the system, causing a reduction or complete loss of braking ability.

MAINTENANCE

When the fluid level is low (i.e. near the LOWER level inscribed on the reservoir) remove the reservoir cover and diaphragm, and refill to the UPPER level.

Check the brake pads for wear when refilling with brake fluid. A low fluid level may be due to wear of the brake pads. If the pads are worn, the caliper piston is pushed out, and this accounts for a low reservoir level.

If the brake pads are not worn and the fluid level is low, check for leakage.

▲ WARNING

- A leak in the brake system can lead to reduced braking efficiency and possible loss of braking ability.
- The recommended brake fluid differs according to models. Certain models take DOT 4, and others take either DOT 3 or DOT 4. Do not use DOT 3 standard brake fluid in a model designated for DOT 4, brake failure may result.

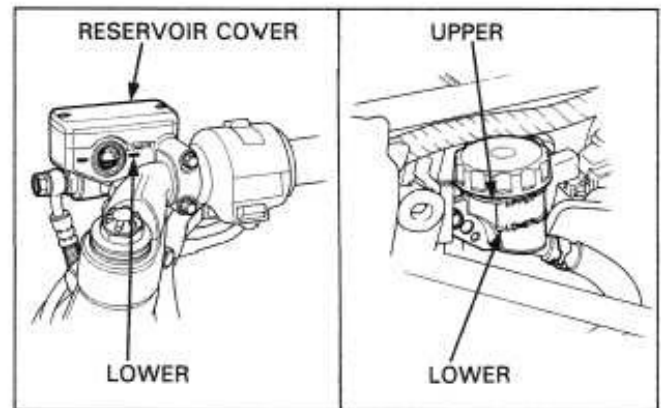

BRAKE SHOE WEAR

If the wear indicator arrow aligns with the "Δ" mark on the brake panel when the brake is applied, remove the wheel and brake panel and check for shoe wear.

NOTE

- If no adjustment remains before the wear indicator limit is reached, this indicates excessive wear and the brake shoes need to be replaced.

Specific brake shoe checks are listed in the Brakes section of the manual.

Inspect the brake drum for wear or damage any time you remove the wheel and brake panel.

If the brake drum shows any signs of cracking or excessive corrosion that cannot be removed with emery cloth, be sure to replace it.

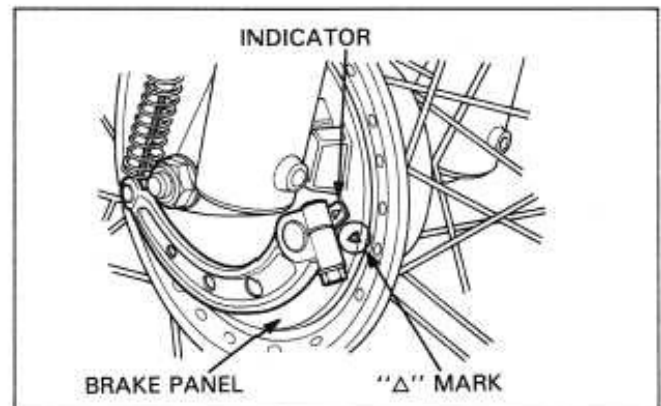

BRAKE PAD WEAR

Replace pads as a set if worn to the brake pad wear limit line (or wear limit groove).

A quick visual inspection can be made at the leading edge of the pads (where the disc enters the caliper).

However, if this proves difficult, a check can be made at the indicator on the caliper marked by the arrow (▲).

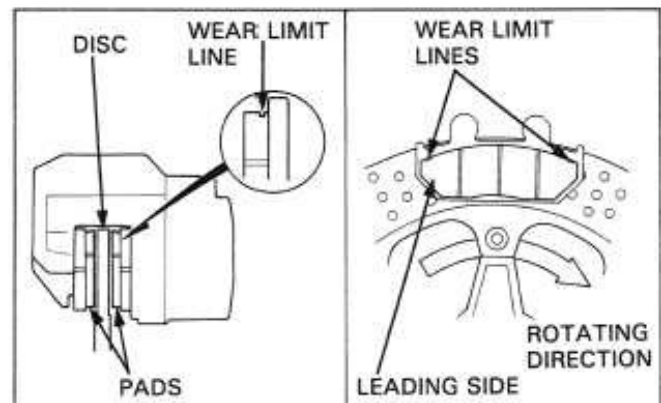

MAINTENANCE

BRAKE SYSTEM

INSPECTION FOR AIR IN SYSTEM

On hydraulic brakes, firmly apply the brake lever or pedal, and check that no air has entered the system. If the lever or pedal feels soft or spongy when operated, bleed the air from the system.

FREE PLAY ADJUSTMENT

On mechanical brakes, measure the free play at the tip of the brake lever or pedal as indicated here and below.

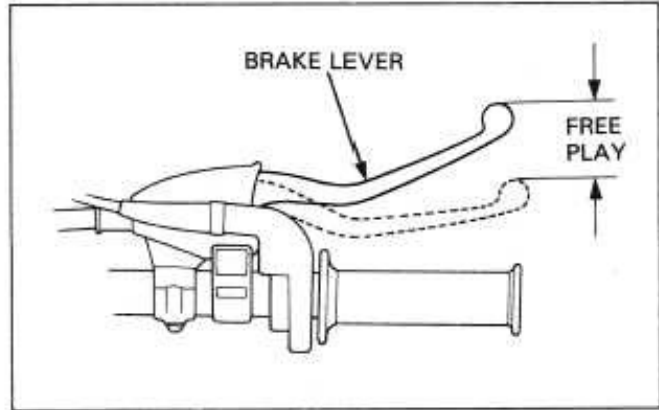

Brake pedals on scooters should be measured for free play as indicated here.

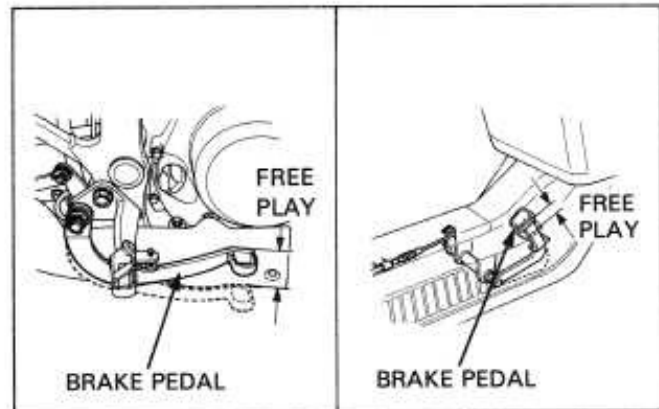

Make adjustments for free play on cable-operated brakes at the end of the cable.

Major adjustments are made on the brake panel end of the cable.

Loosen the lock nut and turn the adjuster nut to correct play at the lever.

NOTE

- If the upper adjuster (on the lever) is screwed in most (but not all) of the way before adjustment is carried out, subsequent adjustment by use of the upper adjuster can be conducted more easily.
- When the brake cable is fastened to the fork by a clamp, loosen the clamp before making brake adjustments.

Secure the adjuster nut and tighten the lock nut on completion of adjustment. Be certain to tighten the fork cable clamp as well.

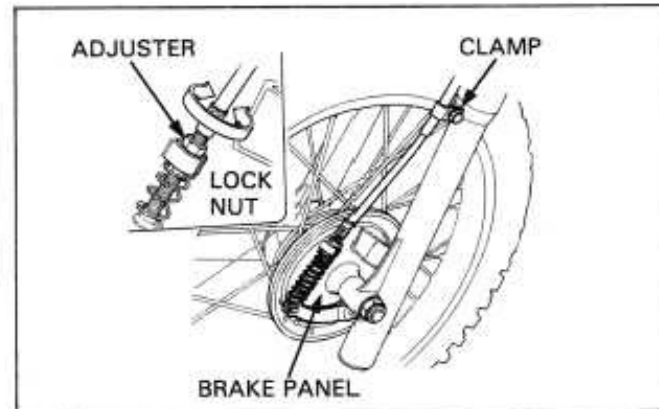

In cases where there is only an adjuster nut, as on many rear brakes, turn the nut to adjust the brake pedal free play.

NOTE

- The adjuster nut's indentation and brake arm pin should seat against one another as shown here in the upper right portion of the illustration to the right. If they do not seat, there may be a change in brake play when the adjuster finally seats in its proper position.

Check for play after adjustment.

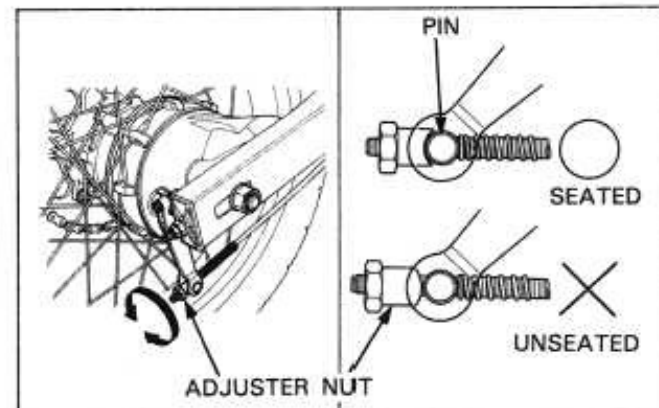

Minor adjustment is made at the lever end of the cable. It is necessary to turn back the lever dust boot to gain access to the adjuster.

NOTE

- There may be damage to the adjuster if it is positioned too far out, leaving minimal thread engagement. When there is more than 8 mm of threads showing, screw in the adjuster most, but not all the way and make adjustments on the brake panel end of the cable.

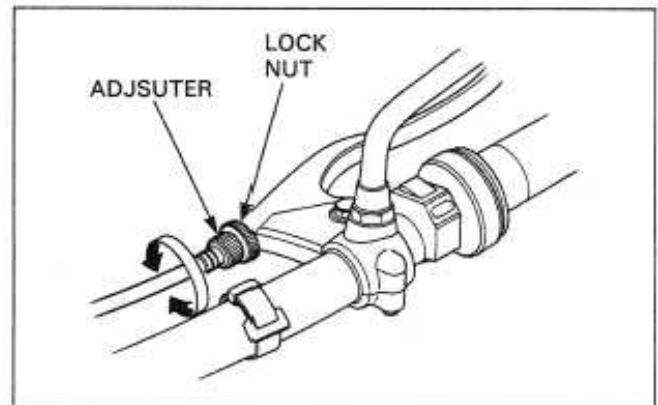

Check for looseness of the following:

- Brake lever and pedal fasteners and adjuster lock nuts
- Brake torque rod fasteners
- Brake rod, cable (mechanically operated drum brake)
- Brake arm (mechanical linkage drum brake)
- Caliper attachment bolt (hydraulic disc brake)

Check that the cotter pins on the brake rod, torque rod etc. are securely in place.

Operate brakes independently while riding in order to determine the effectiveness of each brake.

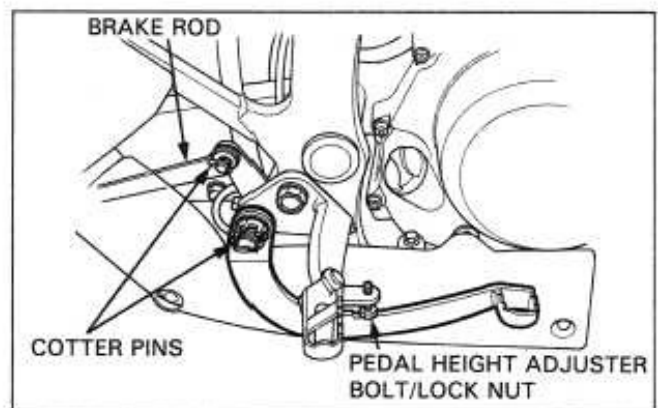

BRAKE PEDAL HEIGHT ADJUSTMENT

Hydraulic brake type:

Loosen the lock nut, and turn the push rod until the correct pedal height is obtained.

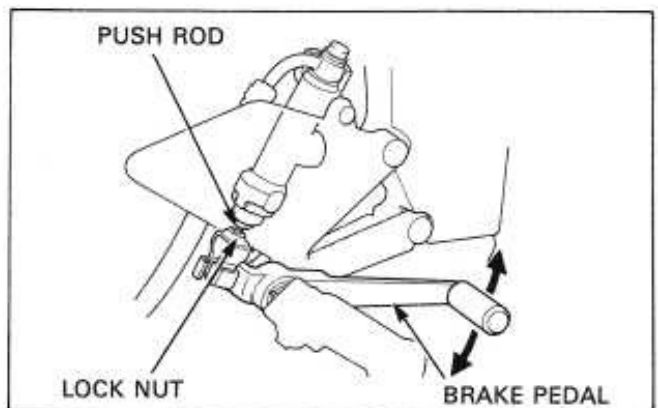

If adjust the brake pedal to the lower position, make sure that the clearance between the lower end of the push rod and the brake pedal end does not fall below 1mm (0.04 in), as shown.

Check for brake light switch operation after adjustment.

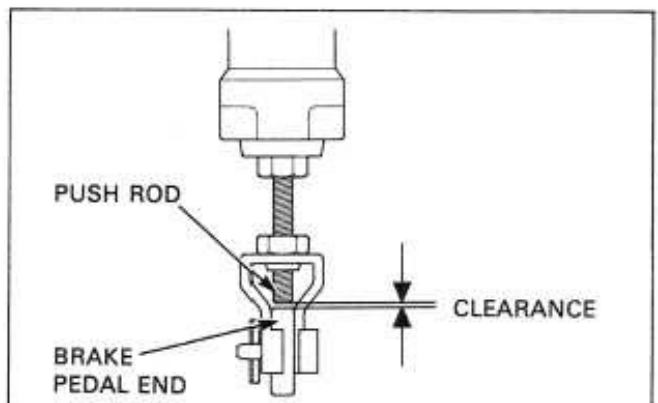

MAINTENANCE

If adjust the brake pedal to the higher position, never enter the lower end of the push rod thread into the brake pedal lower joint, as shown.

Check for brake light switch operation after adjustment.

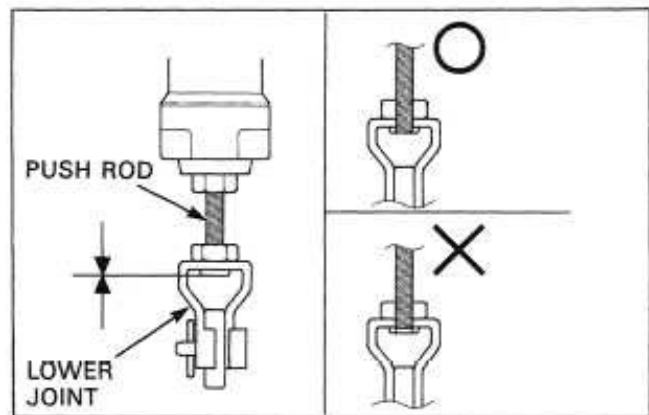

If adjust the brake pedal to the higher position, make sure that the lower end of the push rod pin contact the brake pedal lower joint, as shown.

Check for brake light switch operation after adjustment.

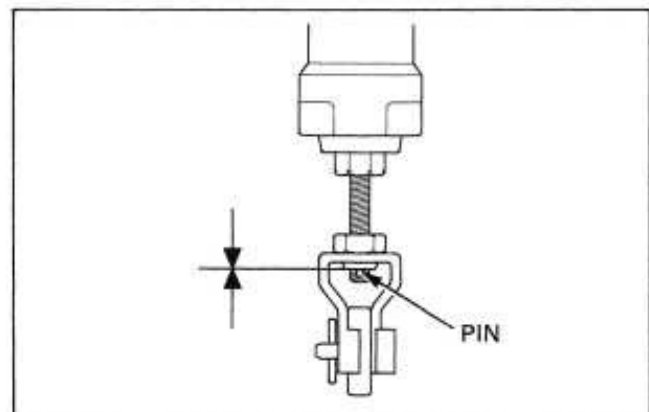

Drum brake type:

Loosen the lock nut, and turn the pedal adjuster bolt until the correct pedal height is obtained.

Check for free play and brake light switch operation after adjustment.

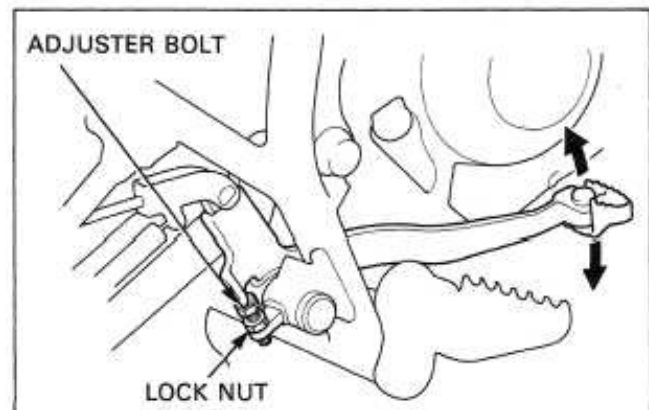

When free play adjustment, never enter the end of the brake rod thread into the adjuster nut, as shown.

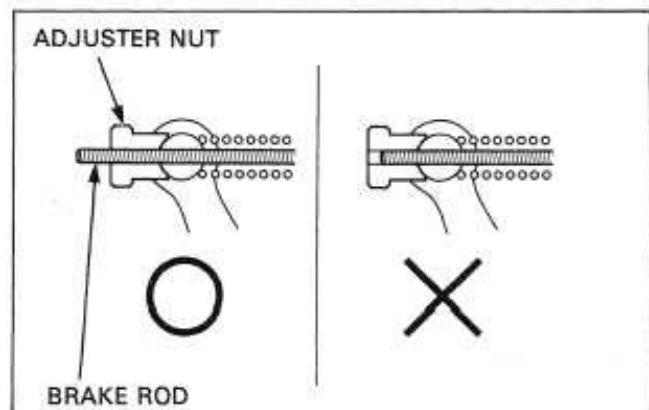

BRAKE LIGHT SWITCHES

Check the brake light switch operation and adjustment by applying the brakes. Visually inspect for any damage and make sure the reflector plate is clean within the light.

Adjust the rear brake light switch so that the brake light comes on just prior to the brake actually being engaged. If the light fails to come on, adjust the switch so that the light comes on at the proper time.

NOTE

- The brake light switch on the front brake lever cannot be adjusted. If the front brake light switch actuation and brake engagement are off, either replace the switch unit or the malfunctioning parts of the system.
- Make all rear brake light switch adjustments after the height adjustment and the brake pedal free play adjustment have been made.

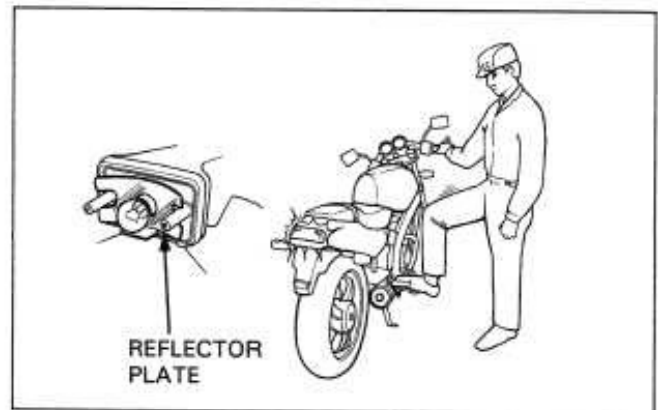

Turn the adjusting nut on the brake light switch and not the switch body and wires to make switch actuation adjustments.

Be sure to hold the switch body firmly while turning the adjusting nut.

CAUTION

- Allowing the switch body to turn during adjustment can break the wires in the switch.

After adjustment, recheck to be sure the brake light comes on at the proper time.

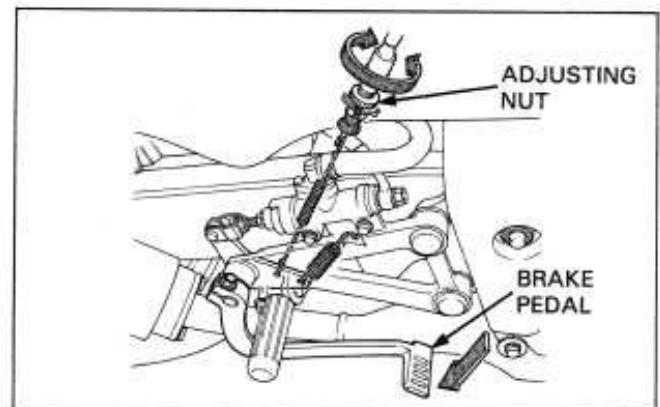

HEADLIGHT AIM

To make a vertical adjustment, loosen the headlight mounting bolts, matching the punch mark on the case and the bracket by moving the headlight up or down. Some motorcycles have an adjusting screw on the bottom of the headlight. In this case, turn the screw to make the vertical adjustment.

For those having an adjusting screw on the side of headlight rim, turn this screw to make the horizontal adjustment.

On some models the headlight is completely encased. The adjustment can be made either with the light beam adjustment knob on the back of the light case or with a remote-type cable and knob. Refer to the Model Specific manual for the proper adjustment method.

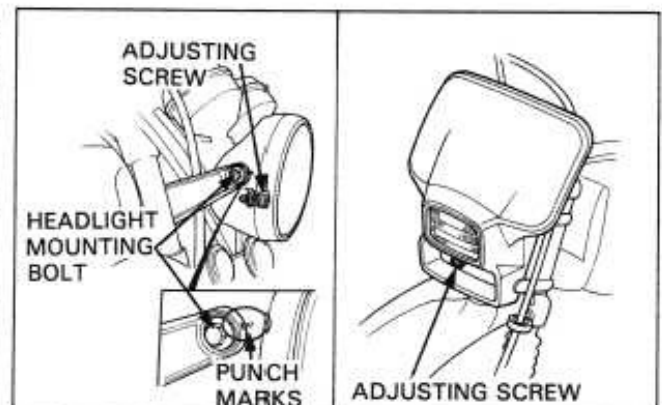

MAINTENANCE

CLUTCH SYSTEM

Check the play at the end of the lever on cable operated clutches.

A lot of play results in clutch drag and stiffness in operation of the shift pedal.

Too little play, however, results in clutch slippage.

When the clutch play is not adjusted within the prescribed amount, correct this using the adjuster located at the end of the cable.

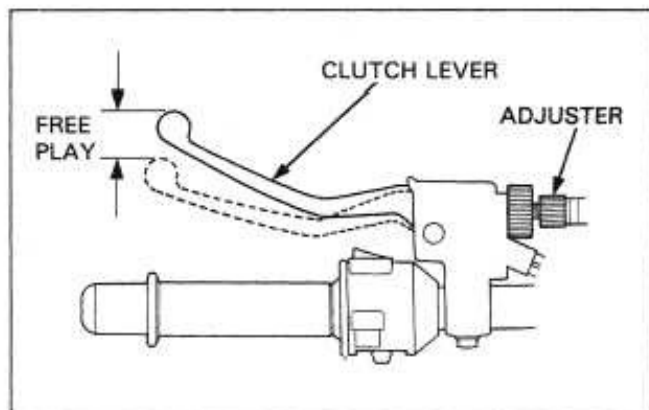

Major adjustment is carried out at the clutch arm. Loosen the lock nut and turn the adjuster nut to adjust play.

NOTE

- Before adjusting cable play at the clutch arm, screw the adjuster at the lever end of the cable in most, but not all the way. This makes subsequent adjustment at the lever end easier.

After adjustment is complete, hold the adjuster nut securely while tightening lock nut.

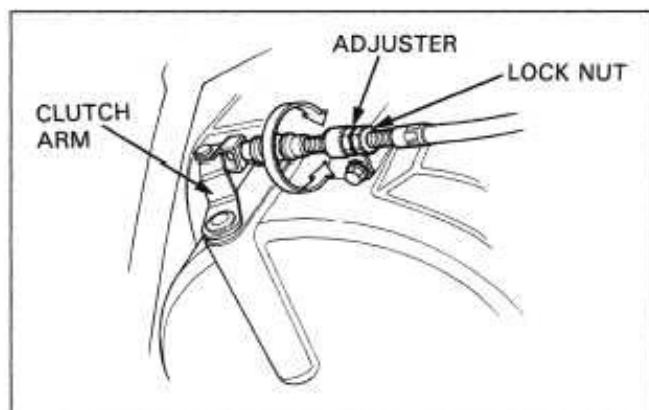

Minor adjustments are made at the lever.

On models equipped with a dust cover, turn back the cover to allow adjustment.

Loosen the lock nut and turn the adjuster to correct the play.

CAUTION

- The adjuster may be damaged if it is positioned too far out, leaving minimal thread engagement.

When more than 8 mm of thread is showing, screw the adjuster in most, but not all the way, and make adjustments on the clutch arm end of the cable.

On models with the adjuster located within the length of the cable (i.e. not at the end), loosen the lock nut and turn the adjuster to alter the play, in the same manner as described above.

On centrifugal clutch

Loosen the lock nut, tighten the adjuster bolt by about 1 turn, then screw it back in until pressure is felt on the bolt.

From this position, loosen the bolt 1/8 of a turn and tighten the lock nut.

NOTE

- When tightening the lock nut, be sure that the adjuster bolt does not turn with it.
- Check the operation of the clutch after adjustment.

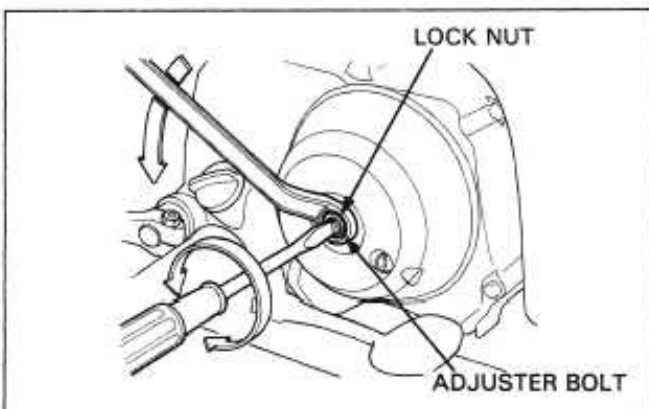
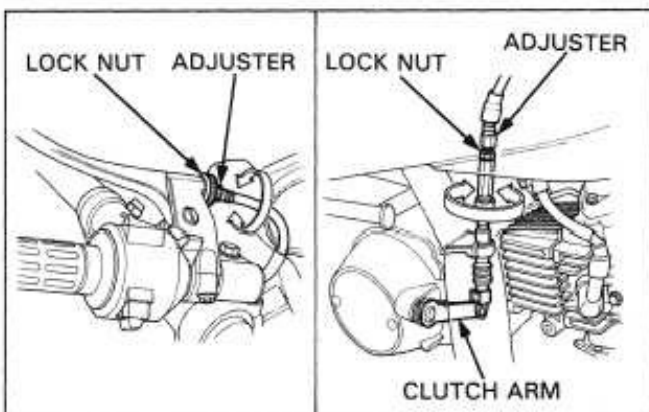

Clutch fluid level

Adjustment for play cannot be made on hydraulic clutches. However, a check should be made of the fluid level. If the level is near the LOWER limit inscribed on the reservoir, remove the reservoir cover and diaphragm, and refill to the UPPER level with the proper type of fluid.

Before removing the reservoir cover, turn the handlebar until the reservoir is level. Place a rag over painted, plastic or rubber parts whenever the system is serviced.

CAUTION

- Spilling fluid on painted, plastic or rubber parts will damage them.

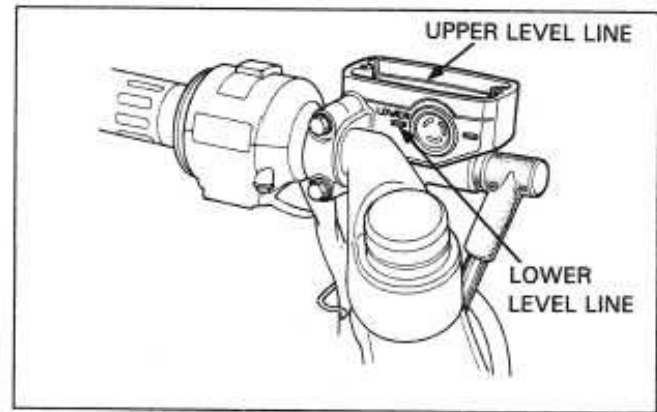

Refill with the recommended fluid.

CAUTION

- Mixing incompatible fluids can impair clutch operating efficiency.
- Foreign materials can clog the system, causing a reduction or complete loss of clutch ability.

SIDE STAND

Conventional Type

Check the wear of the side stand rubber.

Replace it if it has become worn.

Support the motorcycle in an upright and level position, using a support (use the center stand if available).

Hook a spring scale to the end of the side stand rubber and check the load before the stand starts moving.

Acceptable load measurements for side stands:

2–3 kg (4.4–6.6 lbs) (Road-type)

3–5 kg (6.6–11.0 lbs) (On/Off Road type)

If the stand moves too easily, tighten the pivot bolt and recheck. If it still does not have the required tension measurement, replace the return spring.

See if the side stand moves smoothly and retracts fully. If not, grease the pivot.

Check the side play on the side stand. If it is too great tighten the pivot bolt. Recheck and if it is still too great, replace the parts as necessary.

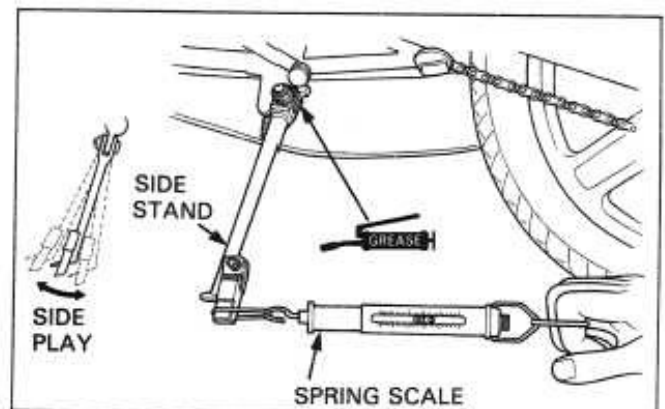
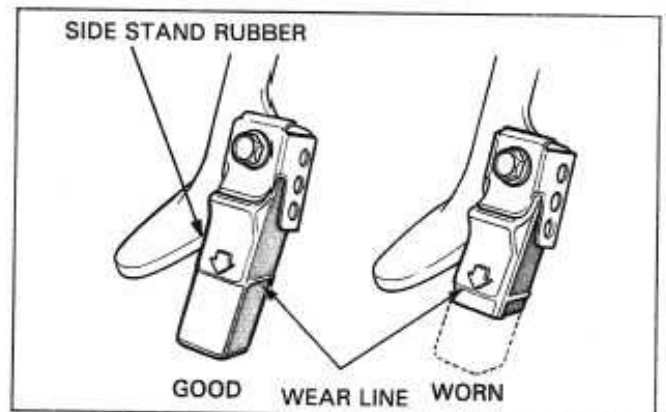

MAINTENANCE

Dual Motion Type

The side stand should lower easily to its first stop, then lock after moving farther forward to support the motorcycle as the rubber touches the ground.

When the motorcycle is lifted upright, the stand should automatically move to the first position, and retract when kicked up.

If the side stand does not move freely, disassemble it:

Remove the return spring at the retracted position. Remove the pivot bolt and remove the side stand assembly from the frame.

Check the following parts for wear or damage:

- inside of the pivot and pivot collar
- pivot dust seals

Lubricate the pivot area with clean grease and reassemble the side stand.

CAUTION

- Install the dust seal with its mark side facing in.
- Make sure that the dust seal spring is seated on the outside of the seal lips after installing the pivot collar.

Recheck the side stand movement.

Inspection For Side Stand With Ignition Cut-off Switch

Check the spring for damage or loss of tension. Check the side stand assembly for freedom of movement. Lubricate the pivot bolt and the side stand pivot area if necessary.

Tighten the pivot bolt and nut. Refer to the Model Specific manual for specified torque.

Check the side stand ignition cut-off switch:

- Sit astride the motorcycle and raise the side stand.
- Start the engine with the transmission in neutral, then shift the transmission into gear, with the clutch lever squeezed.
- Move the side stand full down.
- The engine should stop as the side stand is lowered.

If there is a problem with the system, check the side stand switch.

SUSPENSION

Compress the front and rear suspension a few times. On models with exposed suspension springs, check for cracks and damage.

WARNING

- Loose, worn, or damaged suspension parts impair vehicle stability and control. Repair or replace any damaged components before riding. Riding a vehicle with faulty suspension increases your risk of an accident and possible injury.

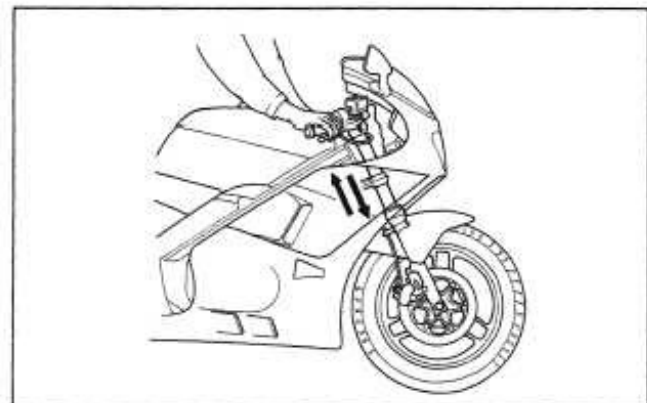
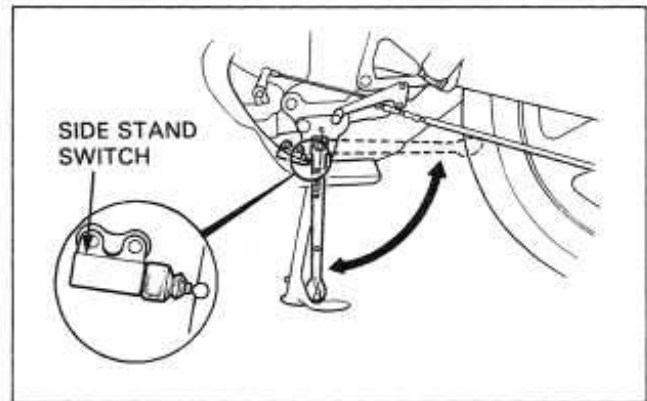
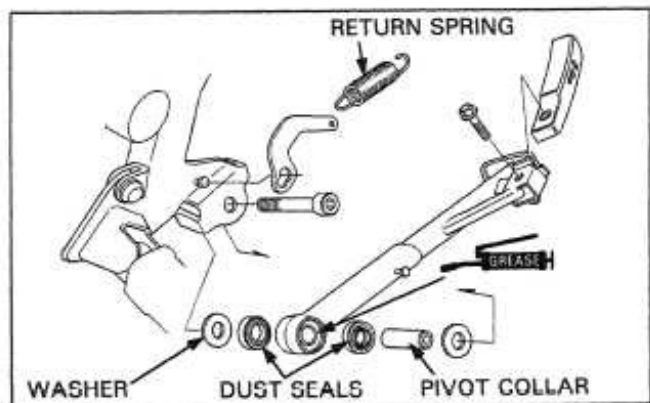
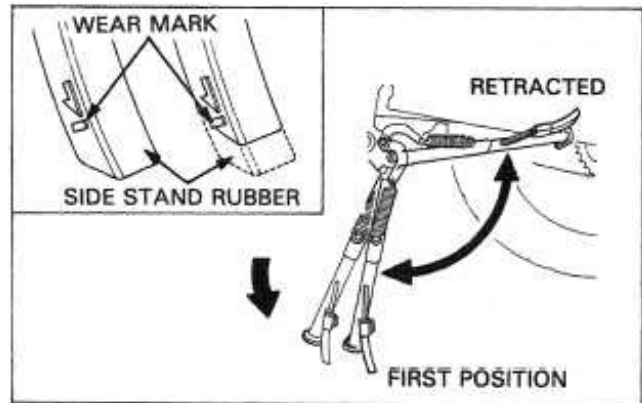

Check for squeaks in the suspension movement that could indicate a lack of lubrication. Try to push the swingarm from side to side to check for worn, damaged or loose suspension pivot components.

If any play is detected, check for looseness of the swingarm pivot bolt.

Check also for wear or damage to the pivot bearings (or bushings).

If looseness is detected in the up-down motion at the end of the arm on Pro-link suspensions, check for wear or damage to the shock absorber mount pivot point.

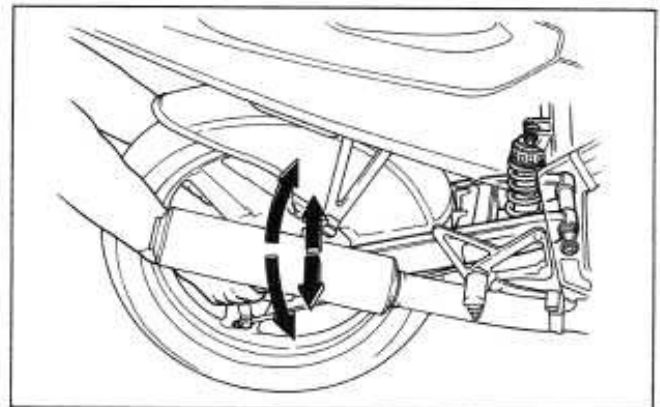

Check for leakage from the oil seals on the fork, damage from stones or scratch marks on the working surface of the fork tubes, and wear and peeling of the chrome plating.

On models equipped with rubber boots on the fork legs, turn back the boots to allow inspection.

If the fork is in poor condition, disassemble and replace parts as necessary.

NOTE

- Replace any fork tube that is heavily scored.

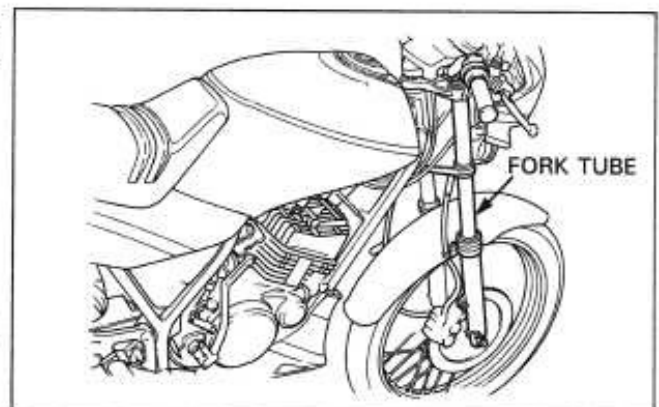

On models with bottom link type front suspension, check for cracks and damage to the fork rocker arms (bottom links). Check for play in the fork rocker arm bearing section, and inspect all fasteners for looseness.

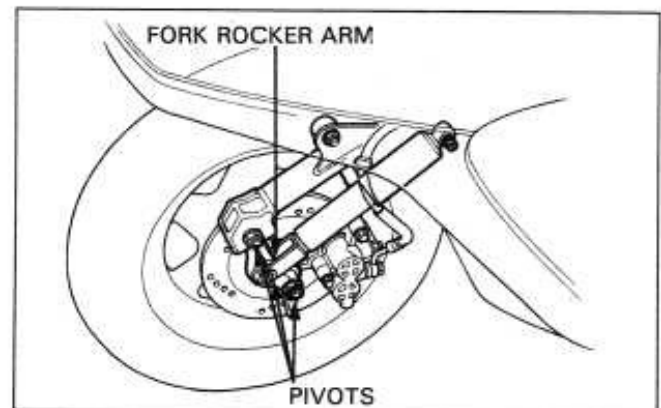

Check for oil leakage around the shock absorber piston rod. Inspect the rod for scoring, wear and peeling of the chrome plating on the working surface.

Check for looseness, cracks and damage to the attachment points of the shock absorber assembly. Re-tighten nuts/bolts if necessary.

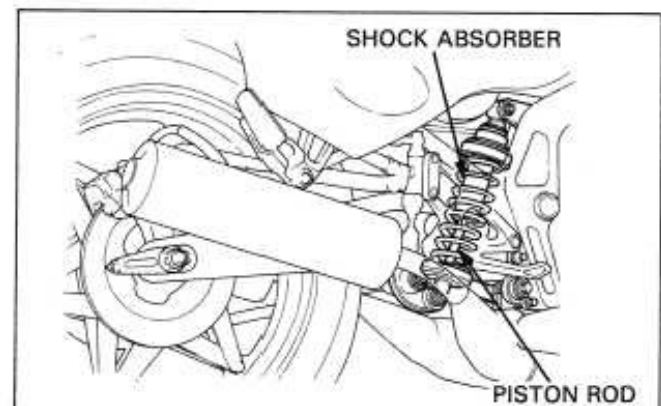

MAINTENANCE

SPARK ARRESTER (USA only)

▲ WARNING

- Wait until the pipe has cooled before removing or installing the muffler lid. Touching the hot exhaust may result in severe burns.
- Perform this operation in a well-ventilated area free from combustible materials. Carbon particles may blow out of the clean out hole when performing this service. Wear safety glasses to prevent possible eye injuries.

Remove the muffler lid. Block the end of the muffler with a shop towel.

Start engine and rev it up to blow accumulated carbon deposits out of the muffler.

Be sure that the muffler lid bolts and gasket are in good condition. Replace the bolts and gasket if necessary.

Install the muffler lid and gasket and tighten the bolts securely.

NOTE

- Do not remove the two screws that hold the exhaust baffle in the end of the spark arrester/muffler.
- The two mounting screws must be installed in the spark arrester body at all times for the spark arrester to be effective.

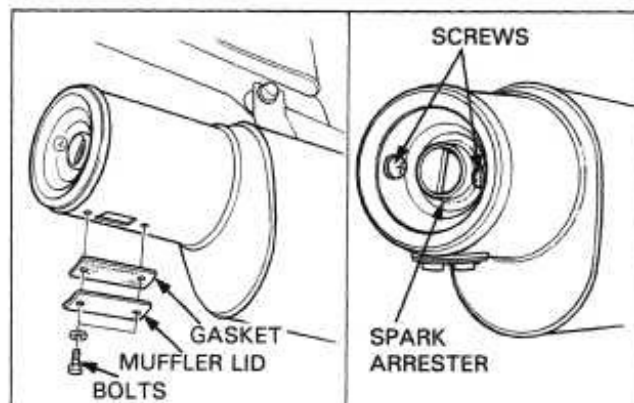
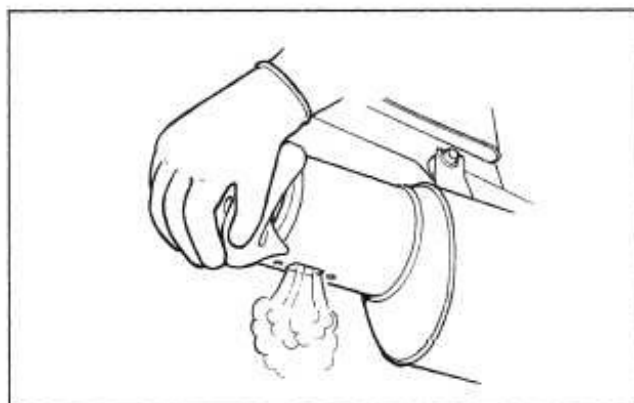
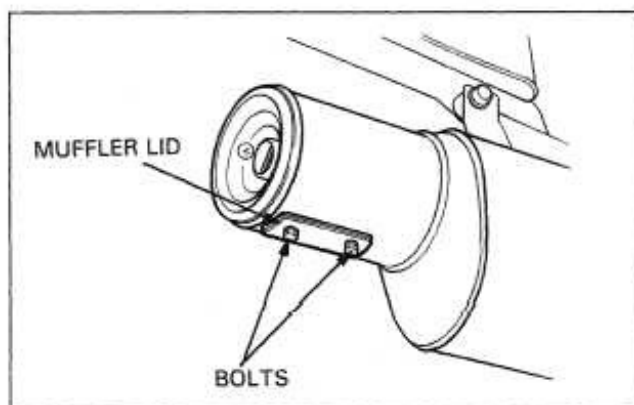

NUTS, BOLTS, FASTENERS

Check that all chassis nuts, bolts and screws are tightened to their correct torque values at the intervals shown in the Maintenance Schedule.

Check all cotter pins, slip pins, hose clamps and cable stays.

WHEELS/TIRES

Making sure the fork is not allowed to move, raise the front wheel and check for play. Turn the wheel and check that it rotates smoothly with no unusual noises.

If faults are found, inspect the wheel bearings.

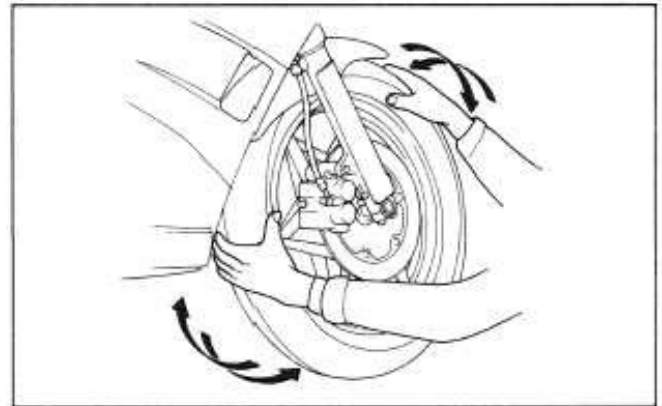

Raise the rear wheel, and check for play in either the wheel or the swingarm pivot. Turn the wheel and check that it rotates smoothly with no unusual noises.

If abnormal conditions are suspected, check the rear wheel bearings.

NOTE

- As the swingarm pivot is included in this check, be sure to confirm the location of the play; i.e. from the wheel bearings or the swingarm pivot.

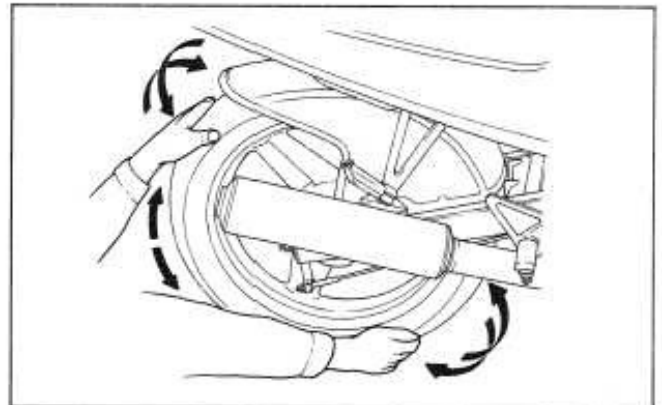

Check for looseness of bolts/nuts in connection with the following.

- Axles
- Axle nuts
- Rim/hub bolts

On models that have cotter pins, check that the pins are attached correctly.

Check for cracks, deformation, damage and corrosion etc. of the following parts.

- Rim
- Wheel
- Spokes

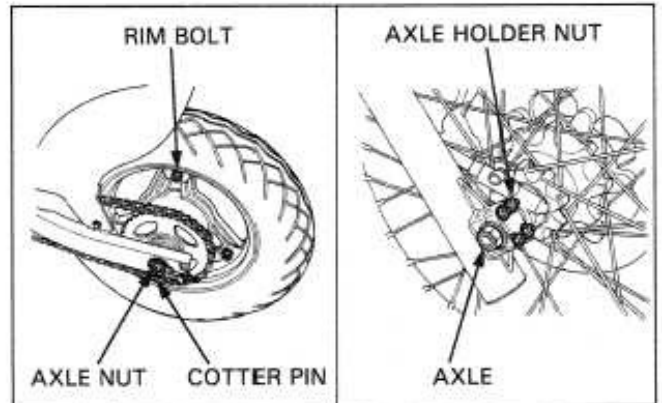

Raise the wheel, turn slowly and check for lateral and vertical oscillation.

Service limit (front and rear wheels)

Lateral direction-Up to 2.0 mm (0.08 in)

Vertical direction-Up to 2.0 mm (0.08 in)

Oscillation of Comstar or cast wheels cannot be corrected. Therefore, check for bearing play or a bent axle shaft. If necessary, replace the wheel assembly.

If there is deformation of the rim on spoked wheels, replace the rim.

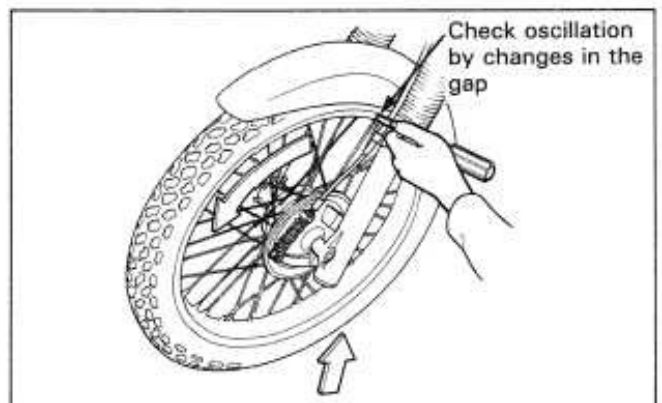

MAINTENANCE

Inspect the spokes for looseness by tapping them with a screwdriver.

If a spoke does not sound clearly, or if it sounds different from the other spokes, tighten it.

Tap on the spokes and be sure that the clear metallic sound of the same tone can be heard on all spokes.

NOTE

- The spoke nipples are made of soft material. Be sure to tighten the spokes with the proper size spoke wrench. After tightening, check the rim for runout.

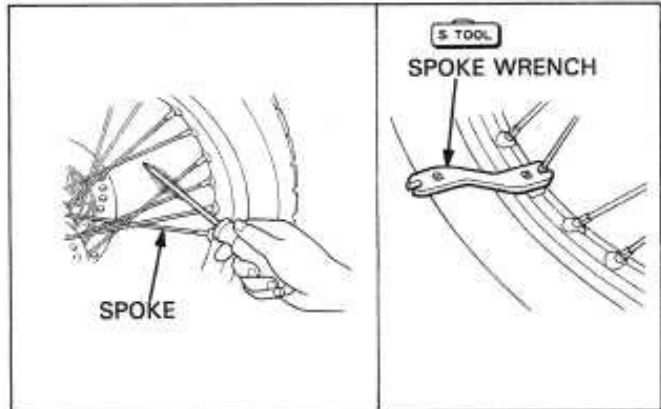

Check the pressure of each tire with a pressure gauge.

Check tire pressures when the tires are cold to assure accurate, comparative measurements. Checking tires after they are warm will give inaccurate readings.

WARNING

- Riding with incorrect tire pressure can affect and impair steering response and may result in a sudden tire deflation.

CAUTION

- Operation without optimum tire pressure will cause uneven tire wear.

Tire pressure specifications differ with each model. Refer to the Model Specific manual for the correct pressures.

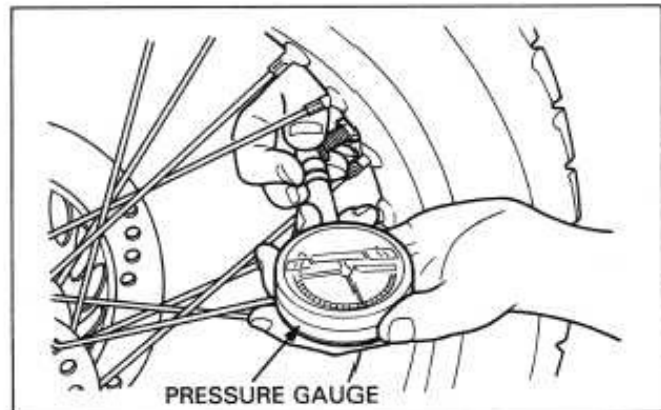

Check for cracks and damage to the tire tread and walls and replace the tire if necessary.

Check for nails, pieces of metal and stones etc. which may have become lodged within the tread or embedded in the tires.

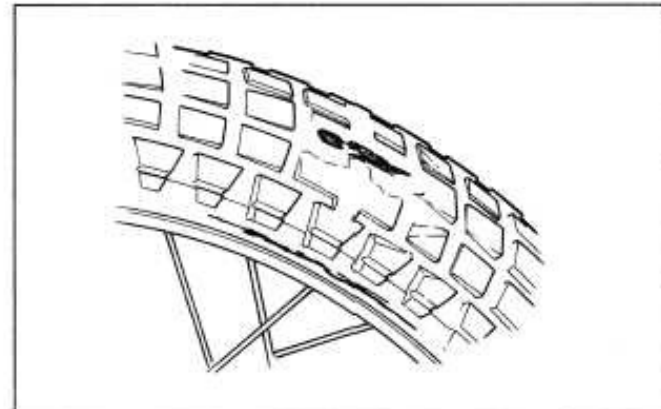

Tread depth can be observed directly or by use of the depth gauge.

- If the tread depth is below minimum tread depth the tire should be replaced.
- Replace the tire if the wear limit indicator can be observed. Check also for uneven wear of the tires.

NOTE

- Wear indicators "Δ" are distributed at several locations around the tire's side wall for ease of inspection.

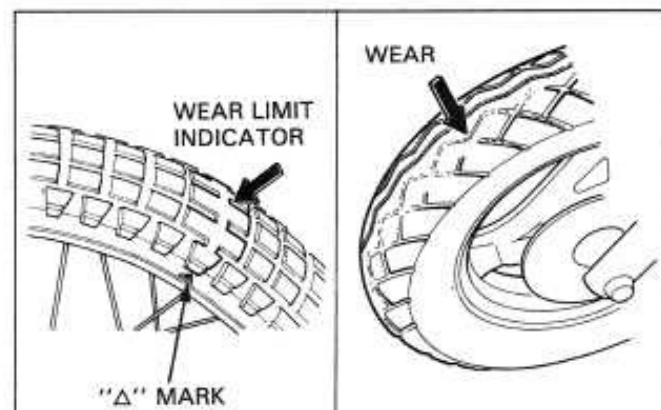

STEERING HEAD BEARINGS

Securely support the vehicle from beneath the frame with the front wheel off the ground. Turn the handlebar from left to right and check that the movement is smooth. If the operation is not smooth or the handlebar snags or has a heavy feel in certain locations, check that there is no interference from cables or wire harnesses. If these are not the cause, check for wear or damage to the steering head bearings.

Check for misalignment of the front wheel with respect to the handlebar. If the wheel is out of alignment, loosen the wheel and fork assembly bolts/nuts, align and re-tighten. If the wheel cannot be aligned, check for bent suspension components or a bent frame.

If the handlebar shows unusual shake during normal running conditions, check the handlebar mounting fasteners and wheel etc.

Turn the handlebar fully from left to right, and vice-versa, to check that there is no difference between the two directions of movement. Check also that there is no interference between the handlebar and frame.

Also inspect for snagging of wires and harnesses on the fork stops on the lower fork bridge.

If the handlebar moves unevenly, binds or has vertical movement, adjust the steering head bearings by turning the steering bearing adjustment nut. Refer to the Model Specific manual for proper procedure.

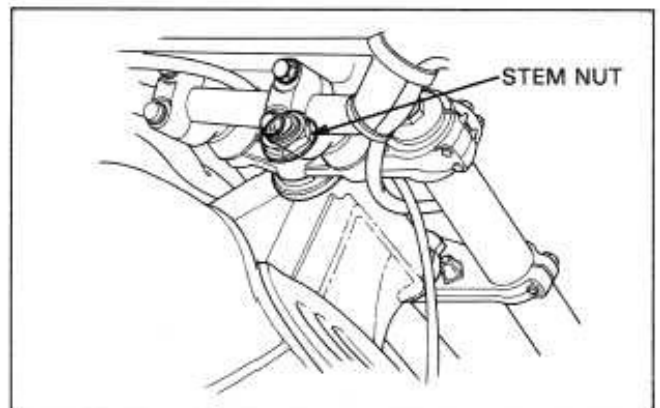
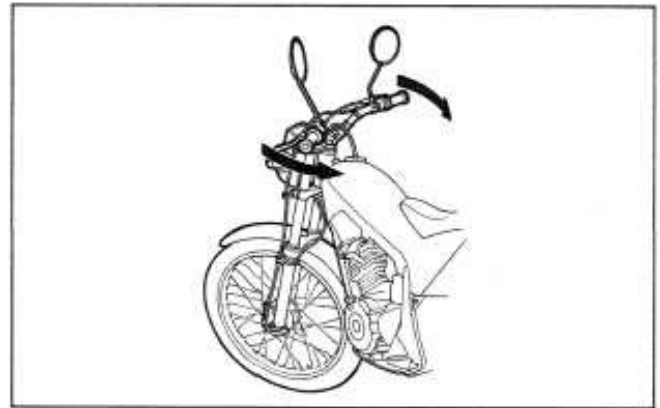

WHEEL ALIGNMENT (FOUR TRAX)

On Four Trax models, inspect and adjust the front wheel alignment (toe-in, camber and caster) as necessary.

TOE-IN

Place the vehicle on level ground with the front wheels facing straight ahead.

Mark the centers of the tires with chalk to indicate the axle center height.

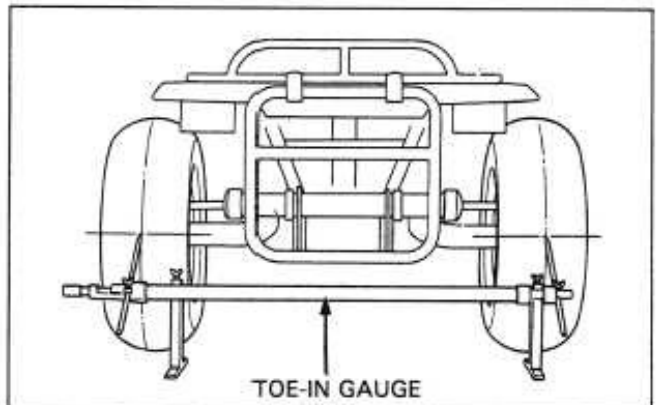

Align the toe-in gauge with the marks on the tires as shown. Check the readings on the gauges scales.

Slowly move the vehicle back until the wheels have turned 180° so the marks on the tires are aligned with the gauge height on the rear side.

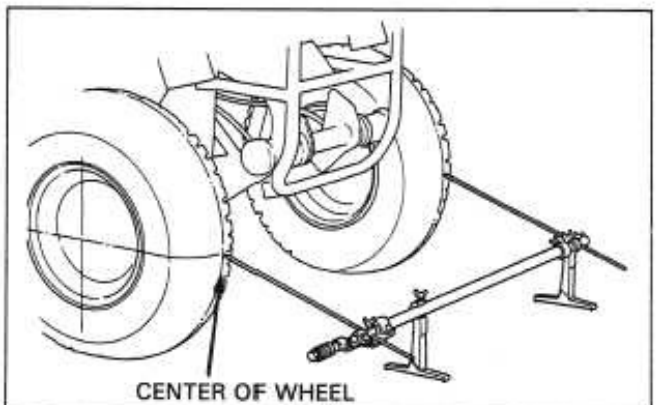

MAINTENANCE

Measure the toe-in on the rear part of the tires at the same points.

When the toe-in is out of specification, adjust it by changing the length of the tie-rods equally while measuring the toe-in.

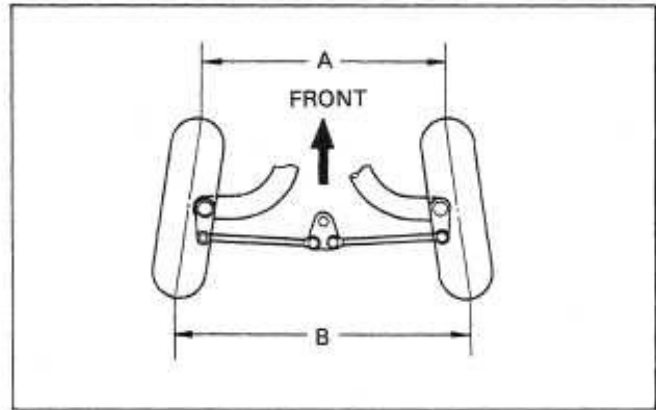

CAMBER/CASTER

Remove the wheel cap, cotter pin and front axle nut.

Install an attachment onto the front axle.

Put the camber and caster gauge onto the attachment.
Measure the camber.

Set the turn gauge under the front wheels.

Measure the caster.

Camber and caster are not adjustable. If they are out of specification, check the suspension and frame for damage and replace any parts necessary, then recheck alignment.

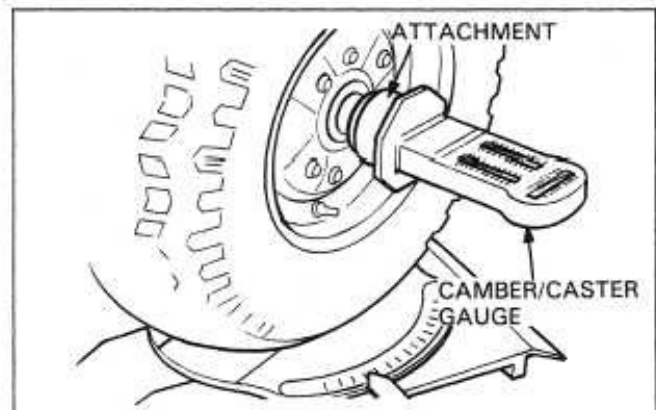

3. ENGINE TESTING

SERVICE INFORMATION	3-1	COMPRESSION TESTING	3-2
TROUBLESHOOTING	3-1	LEAK-DOWN TESTING	3-3

SERVICE INFORMATION

Compression and leak-down tests offer important knowledge of the mechanical condition of the engine in question. Both tests must be done to accurately evaluate engine condition. A compression test can quickly show if all contributing factors allow engine operation within basic service limits or if either the piston rings/cylinder(s), or the valves/valve seats in the case of 4-strokes, are suspect. In order for a compression test to be accurate, the instructions must be followed closely, the engine must contain only standard components and the battery on electric start models must be in perfect condition. A leak-down test can effectively pin-point whether the piston rings/cylinder(s), valves/valve seats, head gasket, or crankcase seals and gaskets in the case of 2-strokes, individually or all together are in need of service.

TROUBLESHOOTING

Cylinder compression is low or uneven

- Faulty valve mechanism
 - Incorrect valve clearance
 - Bent, burned or sticking valves
 - Worn or damaged valve seat
 - Incorrect valve timing
 - Broken valve spring
 - Faulty hydraulic valve adjuster
- Faulty cylinder head
 - Leaking or damaged head gasket
 - Warped or cracked cylinder head surface
- Faulty cylinder or piston
 - Worn or damaged piston ring(s)
 - Worn piston or cylinder
 - Stuck piston ring in the ring groove

2-stroke engines, compression is low or uneven with signs of lean air/fuel mixture

- Crankcase primary compression too low (2-stroke engines)
 - Damaged reed valve
 - Damaged crankshaft seal
 - Damaged crankcase or cylinder base gasket

High cylinder compression

- Excessive carbon build-up on piston or combustion chamber

COMPRESSION TESTING

GENERAL

A compression test is a quick and easy way to check the general condition of an engine. This test should be performed prior to any tune-up work, especially if the machine did not come in under its own power. If the engine has a burnt valve for instance, the customer should be notified that the tune-up will have no benefit without the other necessary engine work. A compression test should also be done if you feel that the motorcycle, scooter or ATV lacks power, especially during acceleration.

A compression test can be inconclusive though, if the engine is not completely stock, if the battery is not in perfect condition (in electric-start models, engine cranking speed may be low) or if the test instructions are not followed completely. In each of these situations, the compression registered will be lower than the service limit in the Model Specific service manual. When you do get a valid compression test, there is something else to consider.

What if the compression is below the service limit, or if the compression is relatively even between each cylinder, and the engine is not smoking? There may be no reason for an expensive rebuild on a good running engine. If, on the other hand, the compression on any one cylinder in a twin or multi-cylinder engine is significantly lower, the engine must be rebuilt.

TESTING

NOTE

- If the motorcycle has a decompressor, be sure it is adjusted properly before checking compression. On motorcycles equipped with an automatic decompression starting system, the decompressors must be deactivated prior to checking.

Warm up the engine to normal operating temperature. Ten minutes of stop and go riding is sufficient.

Stop the engine and remove a spark plug from each cylinder. Install the compression gauge attachment to the cylinder to be tested.

Connect the compression gauge

NOTE

- Make sure that there are no leaks around the attachment.

TOOL:

COMPRESSION GAUGE 07305-0010000

Kick start models:

Fully open the throttle and choke valves, strongly kick the starter pedal through several times, and check the compression.

Electric start models:

Turn the engine stop switch "OFF"

NOTE

- If the engine stop switch is in the "OFF" position the starter motor will not operate. Remove the spark plug cap from the spark plug. Using tape or strings, secure the cap to any convenient plastic body part. Then turn the engine stop switch "RUN" and crank the engine with the starter motor.

Fully open the throttle and choke valves, crank the engine with the starter motor, and check the compression.

NOTE

- To avoid discharging the battery, do not operate the electric starter for more than seven seconds.

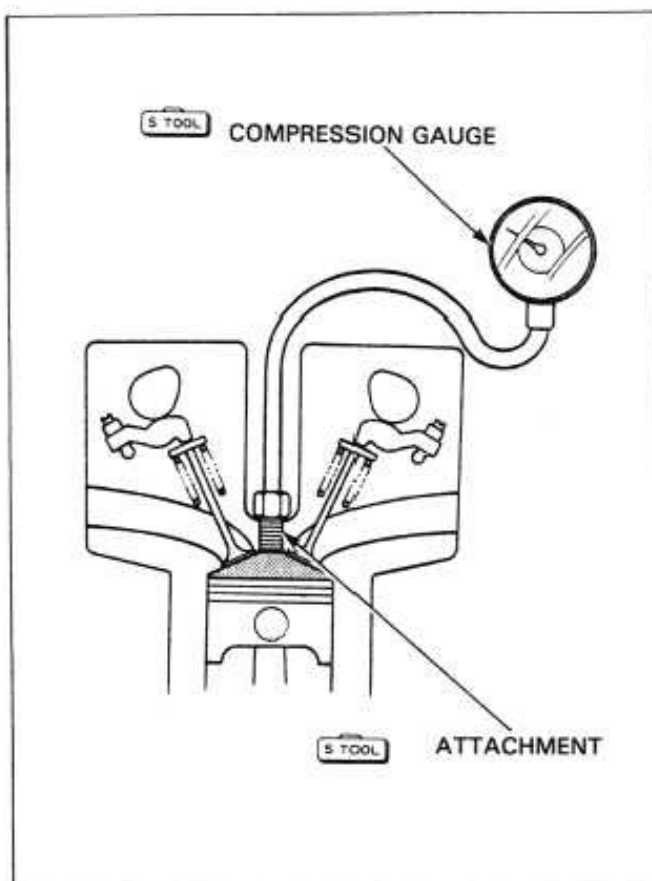

If **compression is low**, drop a small amount of clean engine oil into the cylinder, then recheck the compression.

- If compression increases to more than the previous reading, inspect the cylinder and piston rings.
- If compression remains low, check the valves, valve seats and cylinder head.

If **compression is high**, check for the accumulation of carbon deposits in the combustion chamber and/or on the piston head.

LEAK-DOWN TESTING

4-STROKE LEAK-DOWN TEST INFORMATION

A leak-down test is a more comprehensive engine diagnostic test than a compression test. A leak-down tester consists of a calibrated pressure gauge connected to a pressure regulator and a flow restrictor.

The tester allows you to measure the rate at which air leaks past a cylinder's rings and valves.

There are several tools, specifically designed for leak-down testing 4-stroke engines, that are commercially available from several general tool sources.

A leak-down test provides a clear indication of whether or not the combustion chamber is sealing properly. The test involves pressurizing the combustion chamber and measuring the rate at which the air is lost past the rings and valves (or head gasket). A range of the allowable percentage of leak-down past the rings and valves is suggested by each tester manufacturer. For instance, if the supply of air pressure is 100 psi, and the cylinder is able to maintain a pressure of 90 psi, the cylinder is said to have 10-percent leakage, based on the supply flow rate.

But perhaps more important than a determination of whether the engine needs repair, is to find out more precisely where the problem lies.

The first step in the test is to install the hose from the tool into the spark plug hole, as you would in a compression test. Next position the crankshaft with the piston at top dead center. Be sure to remove the wrench from the crankshaft after positioning in case the air pressure against the piston puts the crankshaft in motion.

Then pressurize the combustion chamber with a steady, regulated pressure, again, as instructed by the tester manufacturer. Now you simply listen to the airbox, exhaust and crankcase filler cap to determine whether the intake valve(s), exhaust valve(s) or rings, respectively, are leaking.

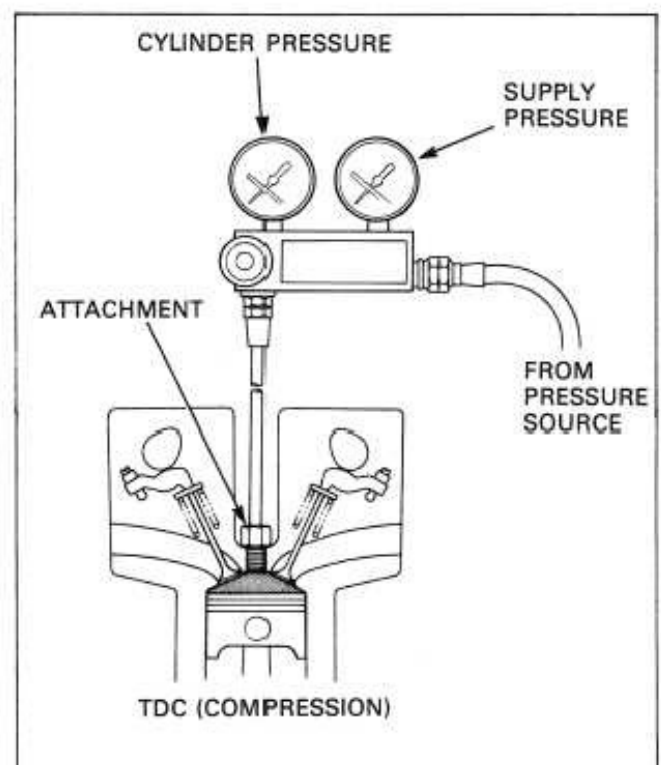

ENGINE TESTING

Squirting a little soapy water around the cylinder and head mating area will tell you if the head gasket is leaking to the outside atmosphere. Checking for bubbles in the cooling system of a liquid-cooled machine will tell you whether or not the head gasket is leaking into the cooling passages. The only thing this test won't tell you is the difference between a head gasket leak into the adjacent cam chain (or gear) well, and a leak past the piston rings.

Be sure to follow the leak-down test tool manufacturer's instructions precisely when making this inspection.

2-STROKE PRESSURE/VACUUM LEAK-DOWN TEST INFORMATION

Regular crankcase leak-down testing is much more important to the lifespan of a 2-stroke engine than a 4-stroke. Because the engine relies on a very precise air/fuel mixture to ensure proper engine lubrication, the slightest air leak can lead to an engine seizure. Consider these regularly scheduled tests as cheap insurance.

Pressure/vacuum tests on 2-stroke engines should always include both a pressure and a vacuum tests, both or which are performed with essentially the same equipment.

Pressure/vacuum leak-down test equipment, specifically designed for 2-stroke engines, is commercially available through various motorcycle and general tool sources.

A pressure/vacuum leak-down test tool consists of hand pressure/vacuum pump and various adaptors to seal your engine. The test provides a clear indication of where a leak, or leaks, exist. Possible areas for leaks include anywhere downstream of the carburetor until the mixture is ignited and forced out the exhaust. Leaks can occur between the mating surfaces of the crankcases if the gasket fails. If this gasket fails between the crankcase and the transmission, the mixture will become much richer as transmission oil is slowly drawn into the engine. Similarly, a leaking crankshaft seal on the transmission primary gear side will also consume transmission oil. Other air leaks include the cylinder base gasket, the magneto side crankshaft seal, leaks between the reed valve assembly and its gaskets, and leaks in the carburetor mounting boot between the carb and the reed valve.

Although some cylinders are more difficult to seal for leakage down testing, such as those equipped with H.P.P. valves, the general procedure that follows can be used on most two-stroke engines.

The first step in the testing procedure is to remove the exhaust and to effectively seal the exhaust port. This is done by bolting a piece of inner tube between the exhaust manifold and the exhaust port, with a plate made specifically to bolt over the exhaust port, backed by a rubber seat, or with some form of expandable rubber plug. NEXT the carburetor is removed and a plug is clamped snugly in place where the carburetor was. This leaves only the seals and gaskets to show any defects they may have. Then an attachment is inserted into the spark plug hole and pressure applied with a hand pump. Often a brake bleeder pressure/vacuum tool is used for this purpose.

Spraying soapy water around the inlet tract, reed valve and crankcase mating areas will produce bubbles where there are leaks.

The vacuum portion of the test ensures that the negative sealing characteristics of the crankshaft seals are adequate.

Be sure to follow the leak-down test tool manufacturer's instructions precisely when making this inspection.

4. LUBRICATION

SERVICE INFORMATION	4-1	OIL PUMP INSPECTION	4-9
SERVICE DATA	4-1	PRESSURE RELIEF VALVE	4-10
TROUBLESHOOTING	4-2	OIL PUMP/OIL LINE BLEEDING	4-11
SYSTEM DESCRIPTIONS	4-3	(2-Stroke Engine)	4-12
OIL PUMP DESCRIPTIONS	4-7	OIL COOLER INSPECTION	4-12
OIL PRESSURE CHECK	4-9		

SERVICE INFORMATION

4-Stroke Engines:

- Refer to the Model Specific manual for:
 - Oil pump removal/installation
 - Oil strainer screen cleaning
 - Oil filter replacement
 - Oil level inspection/oil change
- The service procedures in this section can be performed with the engine oil drained.
- When removing and installing the oil pump use care not to allow dust or dirt to enter the engine.
- If any portion of the oil pump is worn beyond the specified service limits, replace the oil pump as an assembly.
- After the oil pump has been installed check that there are no oil leaks and that oil pressure is correct.

2-Stroke Engines:

- When removing and installing the oil pump, clean the engine around the pump and oil pump itself.
- Do not attempt to disassemble the oil pump.
- Bleed air from the oil pump if there is air in the oil inlet line and each time the oil line is disconnected.
- Fill the oil outlet line with oil whenever the oil outlet line is disconnected.
- Refer to section 2 for oil strainer screen cleaning and oil pump control cable adjustment.

SERVICE DATA

Use only recommended oil for your vehicle. Viscosity requirements vary according to the air temperature range encountered during operation. Refer to the Model Specific manual for specific oil recommendations for the model you are servicing.

GENERAL

Oil recommendations:

4-Stroke engine/ transmission and 2-Stroke transmission oil	API Service Classification: SF or SG Viscosity: SAE 10W-40	
	Other viscosities shown in the chart may be used when the average temperature in your riding area is within the indicated range.	
2-Stroke engine oil	Separate lubrication Mechanical lubrication systems	Pro-Honda Two-Stroke oil or equivalent
	Premix-Type systems	Pro-Honda Two-Stroke oil or equivalent (no concentrates) Refer to Model Specific manuals for recommended fuel/oil ratios.

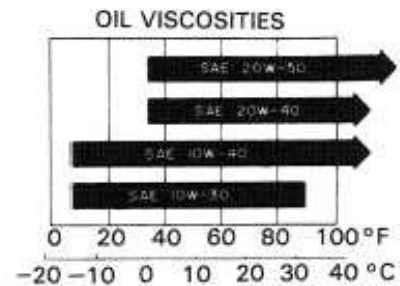

TROUBLESHOOTING

4-Stroke Engines:

Oil level low

- Oil consumption
- External oil leaks
- Worn piston ring or incorrect piston ring installation
- Worn valve guide or seal
- Oil pump worn or damaged (Dry sump engine)

Oil contamination (White appearance)

- From coolant mixing with oil (liquid-cooled engine)
 - Faulty water pump mechanical seal
 - Faulty head gasket
 - Water leak in crankcase

Low or no oil pressure

- Clogged oil orifice and/or orifices
- Incorrect oil being used

Only On Models Equipped With Oil Pressure Switch:

High oil pressure

- Pressure relief valve stuck closed
- Plugged oil filter, gallery, or metering orifice
- Incorrect oil being used

Low oil pressure

- Pressure relief valve stuck open
- Clogged oil filter screen
- Oil pump worn or damaged
- Internal oil leaks
- Incorrect oil being used
- Low oil level

No oil pressure

- Oil level too low
- Oil pump drive chain or drive sprocket broken
- Oil pump damaged (pump shaft)
- Internal oil leaks

2-Stroke Engines With Separate Oiling System:

Excessive smoke and/or carbon on spark plug

- Faulty oil pump (too much oil flow)
- Low quality engine oil

Overheating or seized piston

- No oil in tank or clogged oil line
- Air in oil lines
- Faulty oil pump (too little oil flow)
- Clogged oil strainer
- Oil not flowing out of tank
- Clogged oil tank cap breather hole
- Clogged oil strainer

2-Stroke Engines Using Premixed Fuel/Oil:

Excessive smoke and/or carbon on spark plug

- Improper jetting for altitude, air temperature and track conditions
- Improperly mixed fuel/oil—too much oil in fuel
- Fuel/oil mixture too old—gasoline has evaporated/gone bad

Overheating or seized piston

- Improper jetting for altitude, air temperature and track conditions
- Fuel/oil mixture too old—oxidized oil/degraded lubrication
- Premix oil too old—oxidized/degraded lubrication
- Poor quality premix oil
- Improperly mixed fuel/oil—too little oil in fuel
- Using fuel/oil premix ratio other than recommended

SYSTEM DESCRIPTIONS

4-STROKE SYSTEMS

TYPICAL OIL FLOW PATTERN

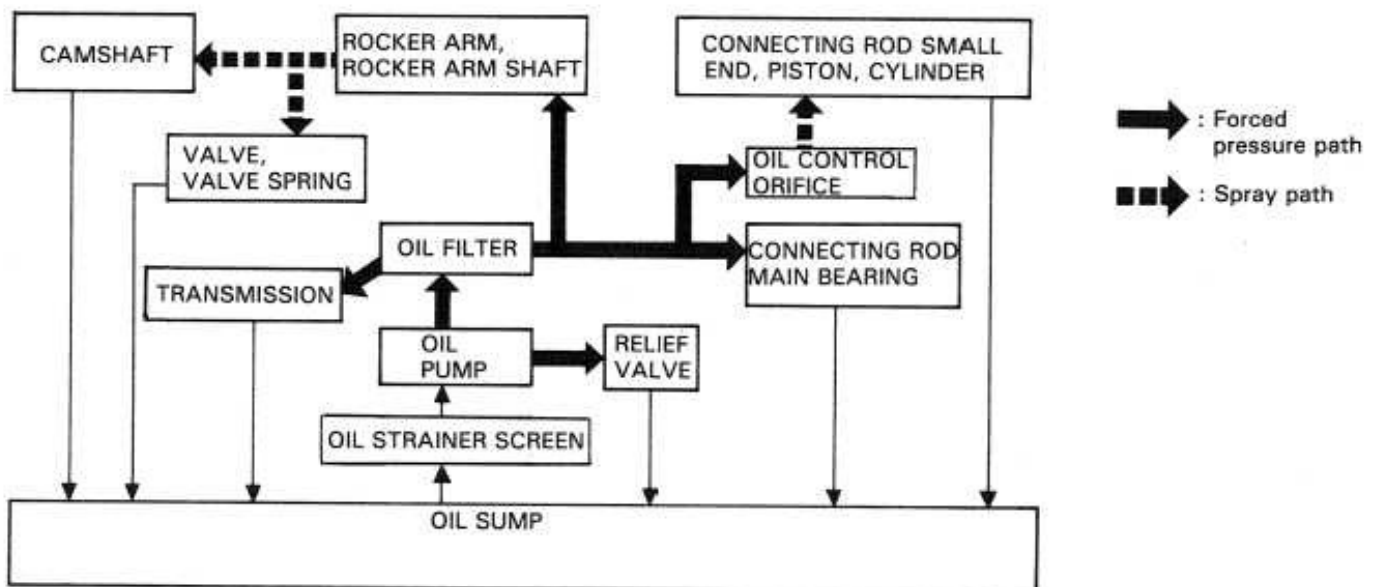
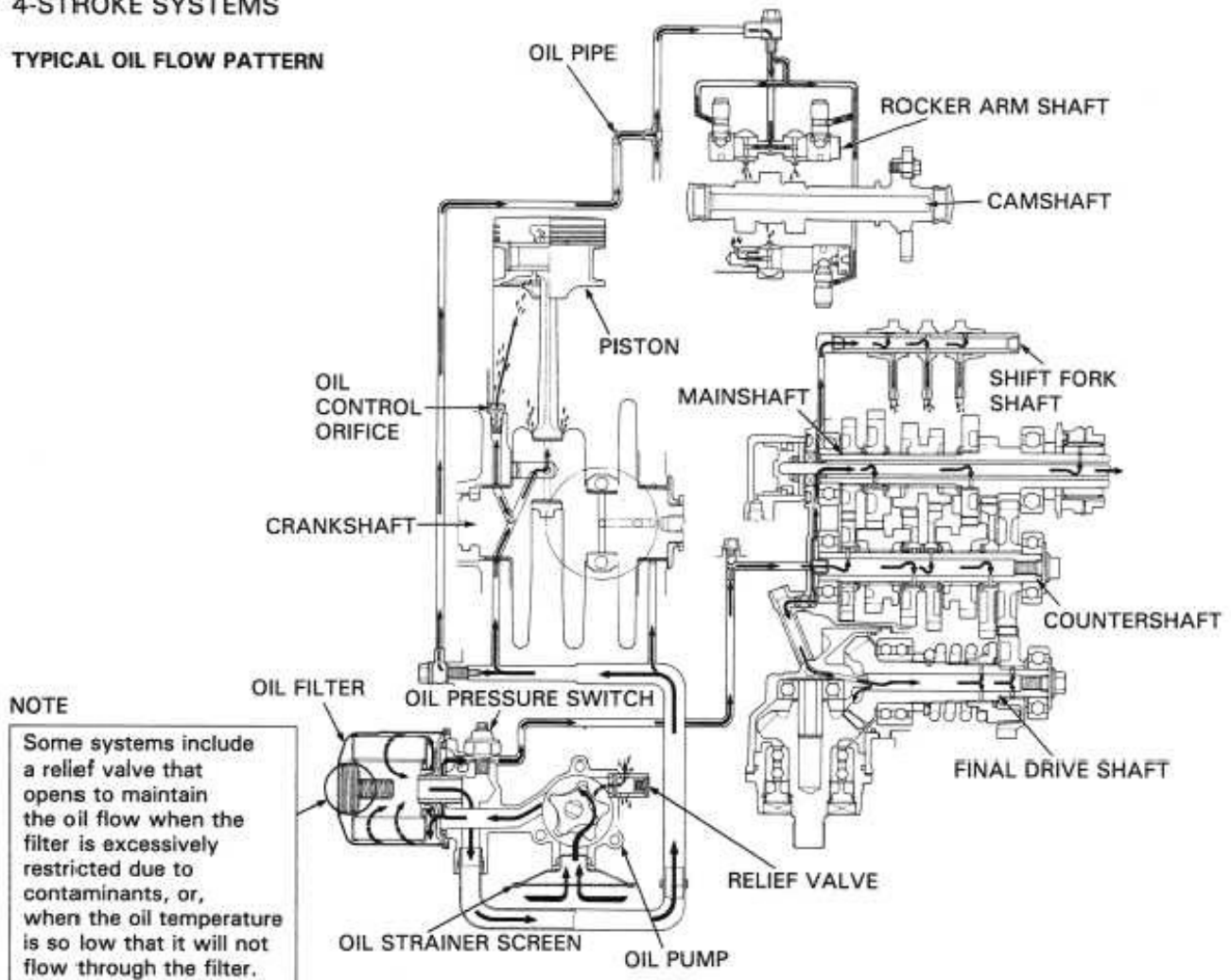

LUBRICATION

FOUR-STROKE ENGINES

Wet-Sump Type

Wet-sump engines contain their total oil volume within their crankcases. In these systems, oil is pumped from the sump in the crankcase, through a strainer screen and/or oil filter and then is pressure fed to various engine components. Oil returning from these now lubricated areas flows back into the sump by gravity.

Some wet-sump engines use only a strainer screen to filter the oil. Others use a combination of a strainer screen and a centrifugal-type filter, or a more conventional pleated paper-type filter.

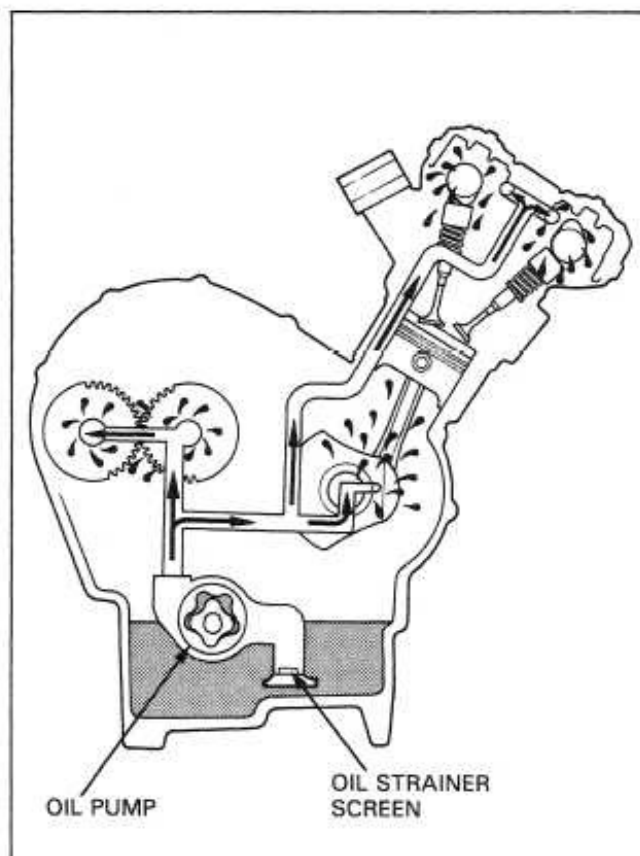

Dry-Sump Type

Dry-sump systems use an external oil tank and dual-function oil pumps. In this system, the pump draws in oil for delivery to the various components and pumps oil out of the sump and back to the oil tank.

Since this design eliminates the need for space to contain the oil within the lower portion of the crankcases, the engine can be positioned lower than would otherwise be possible. This design often incorporates routing and oil storage configurations that aid in lowering oil temperature.

General

A spray-type system is often utilized in either design illustrated here as well as in some two-strokes engine designs. Here oil is literally sprayed through oil jets directly into internal components such as the connecting rod, to help ensure lubrication and cooling of the rods and pistons.

Some systems include oil pressure-controlling relief valves to help ensure lubrication even if the filter is clogged or the oil temperature is so low that it will not flow through the filter.

Oil filters and/or strainer screens are positioned within the lubrication system to trap contaminants before the oil is routed back into the lubricant pathways.

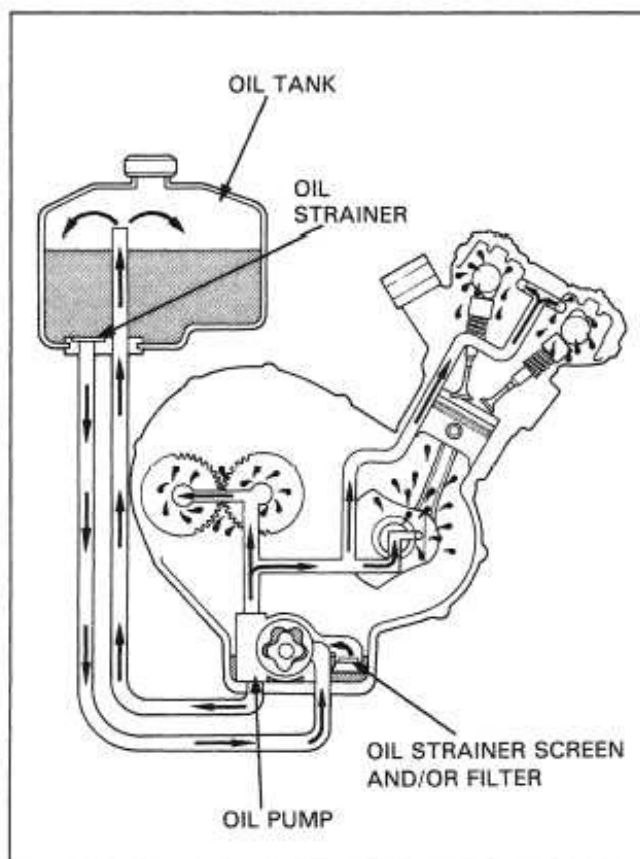

TWO-STROKE LUBRICATION SYSTEMS

Unlike four-stroke engines, two-stroke engines use the internal crankcase area as a suction chamber and, therefore, cannot use a sump-type oiling system. Consequently, the following two systems have been adopted in order to provide lubrication to the cylinder, piston rings, connecting rod and crankshaft bearings. Each system type relies on oil ingested together with the gasoline. In Separate Oil systems, engine lubrication oil is introduced downstream of the carburetor. Oil is combined with the gasoline before it reaches the carburetor in Premixed systems.

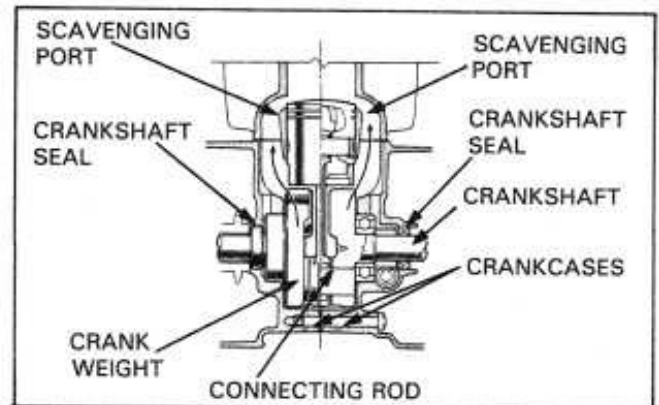

SEPARATE OIL SYSTEMS:

Virtually all street motorcycle and scooter two-stroke engines use a pump-operated system to lubricate engine components. Oil in this type of system is drawn from a separate oil tank by an oil pump that introduces the oil directly into the air/fuel inlet tract beyond the carburetor.

Periodic level checks and refilling of the oil tank is required since the oil in the tank is continually drawn upon when the engine is running.

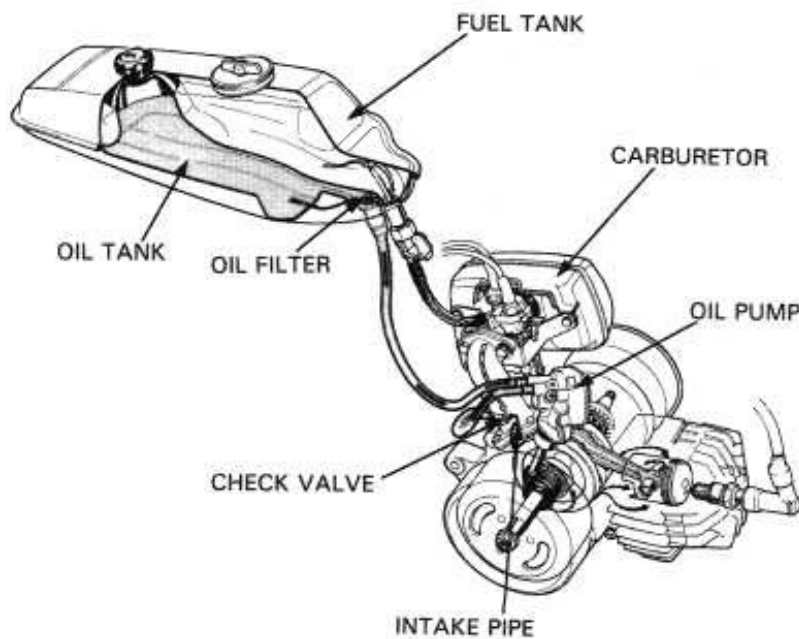

The amount of lubricant delivered to the engine is dependant on both engine rpm and throttle position.

Some of these systems include provisions for circulating the transmission oil within the gearbox portion of the crankcases with the same oil pump.

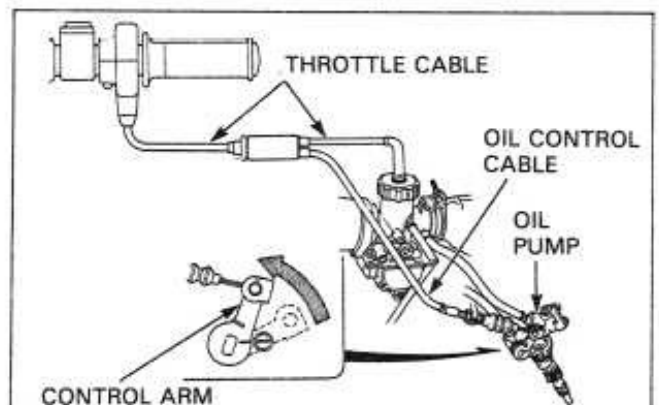

LUBRICATION

PREMIXED (OIL IN FUEL) SYSTEMS:

Premixing engine oil with gasoline is the most widely used system on competition models.

The combined air/fuel/oil mixture is introduced directly through the inlet tract with the assistance of the carburetor. Lubrication to the crankshaft and both connecting rod bearings as well as the piston rings and cylinder walls is achieved as this mixture is drawn into the crankcase by the suction of the piston movement.

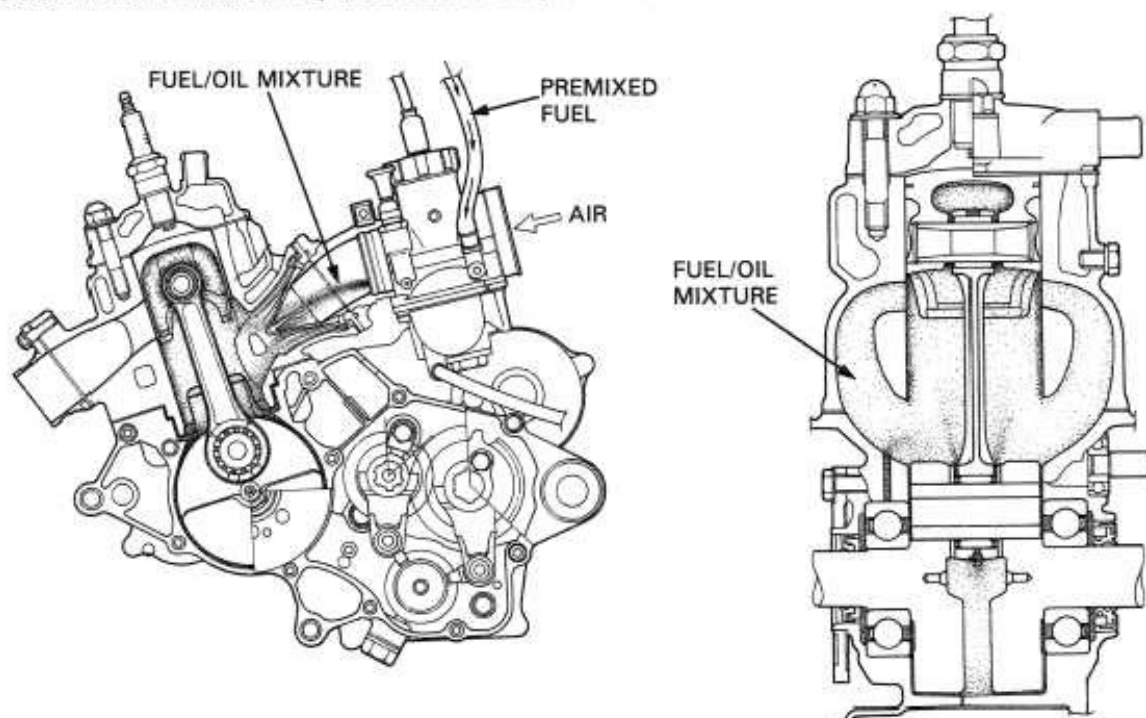

It is important to **USE ONLY THE RECOMMENDED FUEL/OIL RATIO**. All Honda engines are designed to operate most efficiently and with greatest durability using the recommended premix ratio. All standard carburetor jetting is based on this ratio.

Standard jetting is based on the recommended premix ratio at sea level and 20 °C (68°F).

CAUTION

- **Use of a fuel/oil premix ratio other than the recommended may affect overall jetting, engine performance and may lead to premature engine wear or damage.**

Freshness of the fuel/oil mixture is very important to both the overall performance of the machine as well as the lubricating efficiency of the oil.

Only use gasoline that has been pumped from a high-volume station within the previous two weeks if optimal competition performance is required. Even general use applications call for gasoline that is no more than eight weeks old.

For optimal lubrication efficiency in this system, use the premixed fuel/oil within 24 hours after it is mixed. Two-stroke premix oil that is not stored in resealable containers should be discarded in a proper manner if it is not used completely within one month after opening. Oil stored in non sealed container is subject to oxidation that degrades the oil's lubrication qualities.

Vegetable-type premix oils separate from gasoline more easily than mineral oils, especially in cold weather. It is advisable to use mineral oil when ambient temperatures below 0°C (32°F) are expected.

CAUTION

- **Mixing vegetable and mineral-based oils will cause premature engine wear or damage.**

OIL PUMP DESCRIPTIONS

TROCHOID TYPE

The trochoid-type oil pump is the most common oil pump design used in 4-stroke engines. It is designed to turn two rotors within a casing, with an inner rotor fixed on the pump shaft (drive shaft) and an outer rotor on its circumference. When the inner rotor is turned by means of the oil pump shaft, the outer rotor also turns, with the clearance between the two rotors varying. Lubricant is drawn through by suction when the clearance is enlarged. Oil is delivered to the opposite side when the clearance lessens. The more teeth the inner and outer rotors have, the less the amount of pulsation. The oil flow volume increases in direct proportion with the increase in thickness of the rotor dimension.

Some models have a double rotor trochoid-type oil pump which collects oil directly from both the oil cooler and the sump.

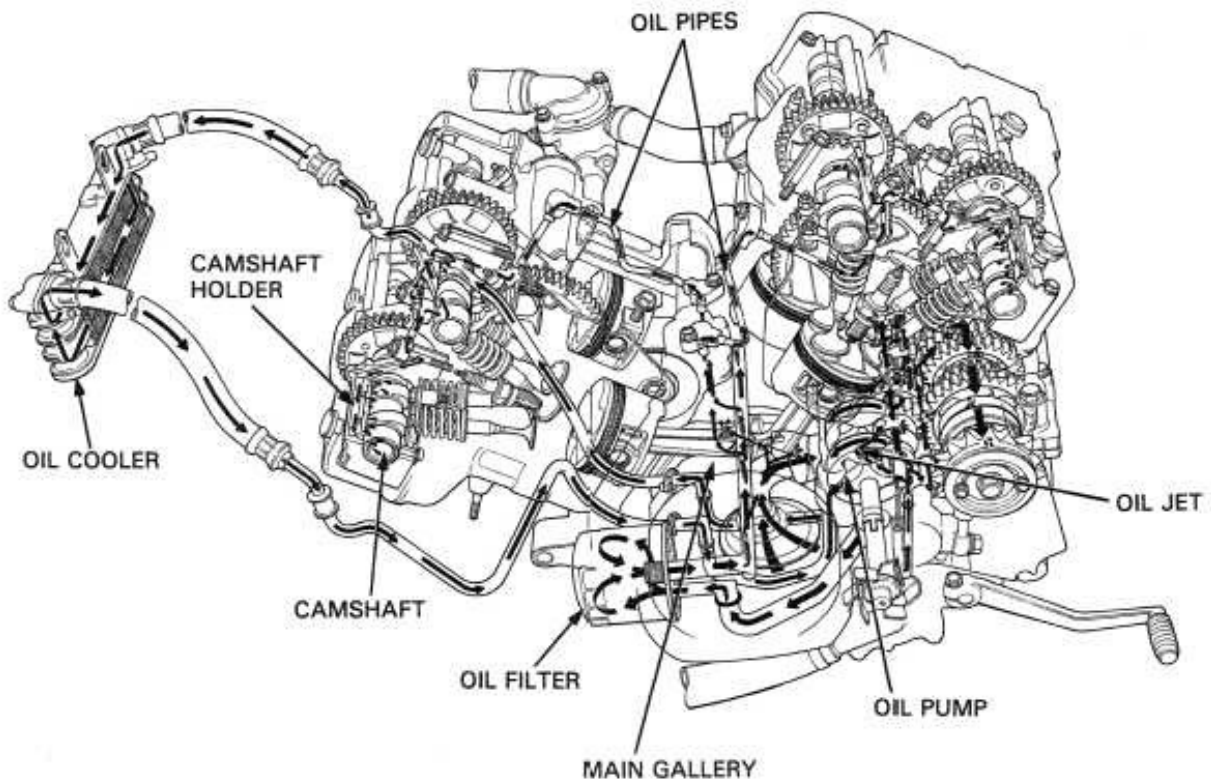
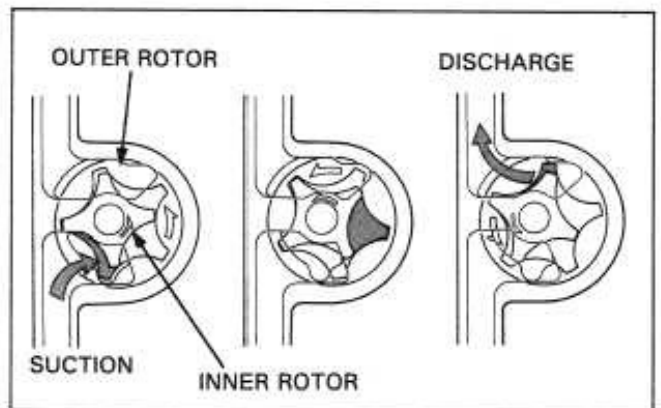
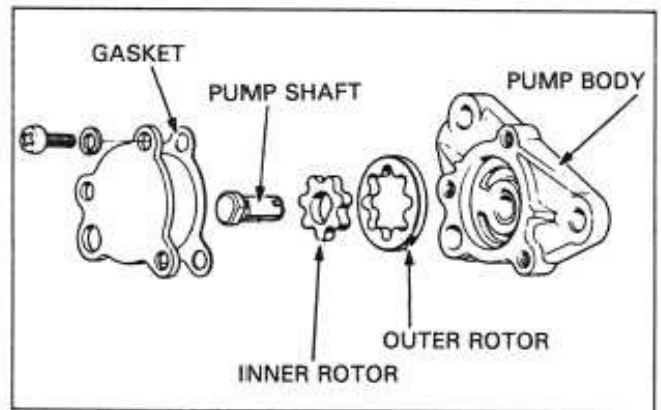

LUBRICATION

PLUNGER TYPE

Virtually all non premix lubricated 2-stroke engines are equipped with a plunger-type oil pump.

Some plunger pumps are driven by crankshaft via the oil pump gear shaft, and others are directly driven by crankshaft.

The oil pump cam is depressed under a spring. Turning the cam causes the plunger to reciprocate so that the pumping movement is repeated. The amount of lubricant is controlled proportionally with the cam rotation.

The pump is designed to control the amount of lubricant discharged per crankshaft rotation by varying the plunger stroke through the operation of the cam interlocked with the carburetor throttle.

The combined function of these two mechanisms allows the proper flow of lubricant depending on load conditions and engine rpm.

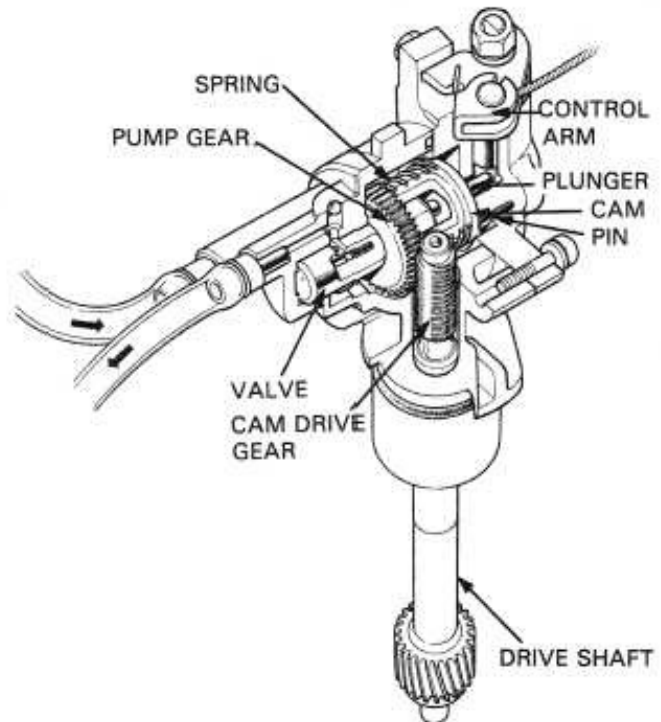

Oil Pump Operating Principle

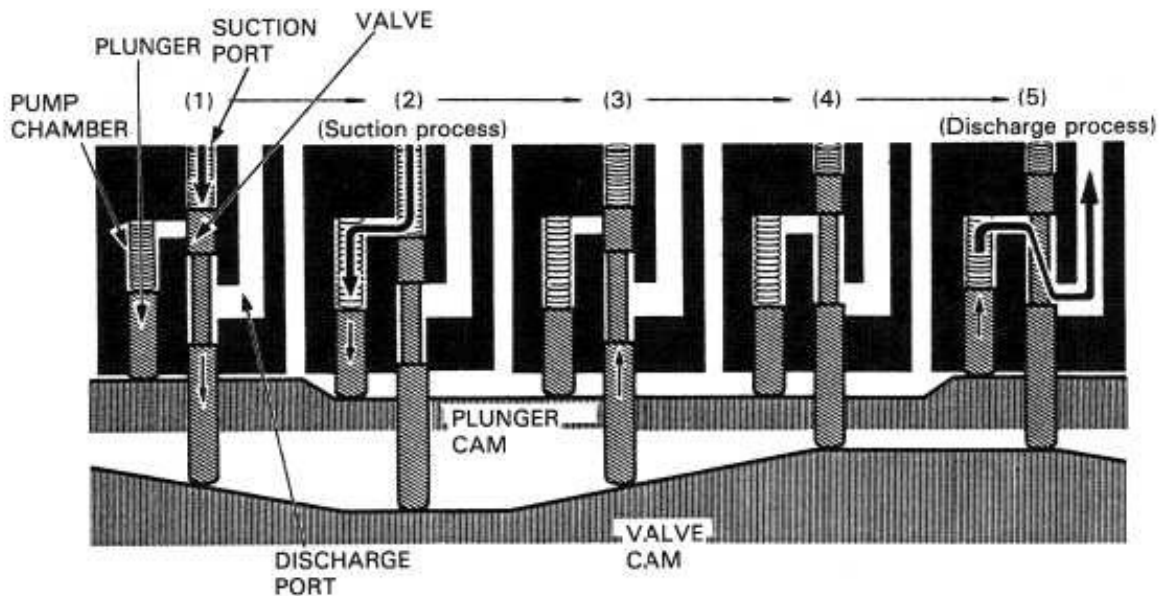

- (1) As the valve descends, it blocks the outlet passage while gradually opening the inlet passage.
- (2) Here at the "bottom dead center" position, the outlet passage is completely closed while the inlet passage is completely opened — allowing free flow of oil into the pump chamber.
- (3) With the oil chamber filled, the valve ascends — closing the inlet passage.
- (4) The valve ascends further, allowing free flow of oil through the outlet passage.
- (5) The plunger also ascends, compressing the oil inside the pump chamber and pumping oil out through the outlet passage, towards the intake pipe via the outlet line.

OIL PRESSURE CHECK

NOTE

- This procedure is for vehicles equipped with an oil pressure switch.
- If the engine is cold, the pressure reading will be abnormally high. Warm up the engine to normal operating temperature before starting this test.
- Refer to the Model Specific manual for specifications.

Stop the engine and pull off the switch cover. Disconnect the switch wire by removing the screw.

Turn the ignition switch ON and check that the oil warning light does not come on.

If the warning light comes on, there is a short circuit in the switch wire. Repair or replace as necessary.

Remove the oil pressure switch (see the Model Specific manual).

Install the attachment as necessary and connect the oil pressure gauge.

S TOOL

OIL PRESSURE GAUGE: 07506-3000000

ATTACHMENT: Refer to Model Specific manual.

Check the oil level and add the recommended oil if necessary.

Start the engine and check the oil pressure. If it is normal, replace the oil pressure switch.

Stop the engine.

Apply 3-BOND® sealant or equivalent to the pressure switch threads and install.

CAUTION

- Overtightening the switch can cause crankcase damage.

Connect the oil pressure switch wire and start the engine.

Check that the oil pressure warning indicator goes out in one or two seconds.

If the oil pressure warning indicator stays on, stop the engine immediately and determine the cause.

OIL PUMP INSPECTION

TROCHOID TYPE

NOTE

- Where there are two pair of inner and outer rotors, check each side of the pump as described below.
- Measure at several places and use the largest reading to compare to the service limit.

Disassemble the oil pump and clean the parts with clean oil.

Set the inner and outer rotors into the pump body properly.

Measure body clearance (pump body-to-outer rotor) and tip clearance (inner rotor-to-outer rotor) using a feeler gauge.

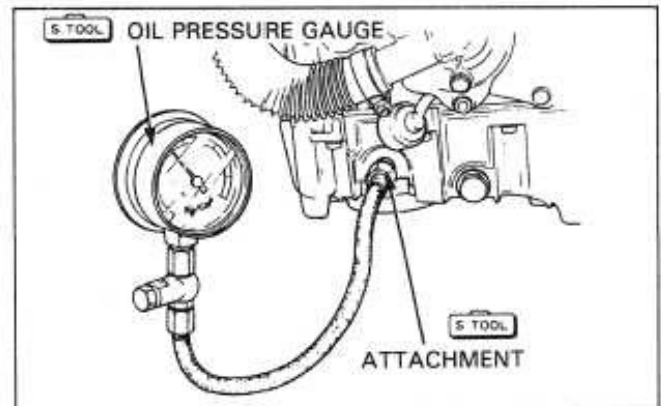

NOTE: Apply sealant only to the area shown.

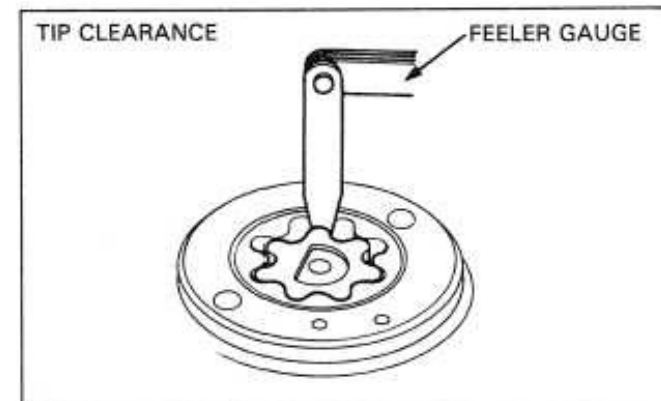
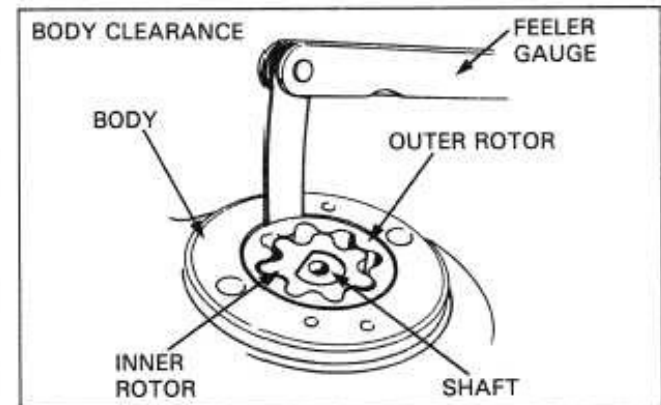
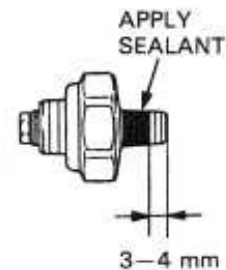

LUBRICATION

Measure the side clearance (rotor side-to-body) with a straight edge and feeler gauge.

NOTE

- If there is a cover gasket, measure the clearance with the gasket installed.

Refer to the Model Specific manual for all clearance specifications.

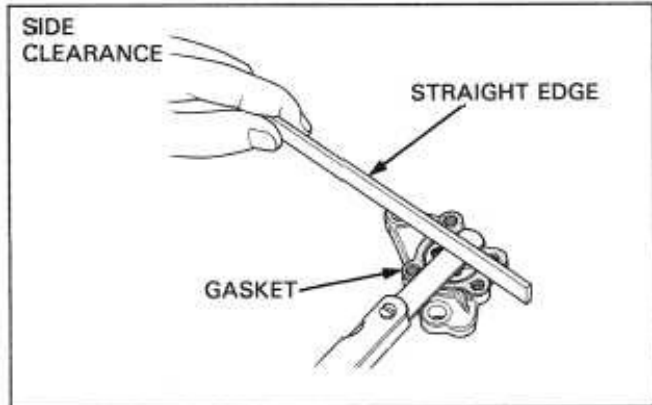

PLUNGER TYPE

NOTE

- Do not disassemble and try to repair a two-stroke oil pump; it will not operate properly once reassembled.
- Replace the pump if it is worn or damaged.

Remove the oil pump and inspect for the following:

- Worn or damaged pump gear
- Oil leaks from seals
- Binding pump shaft

Connect the oil tube from the oil tank to the suction side, then turn the shaft. Check that oil flows out of the outlet.

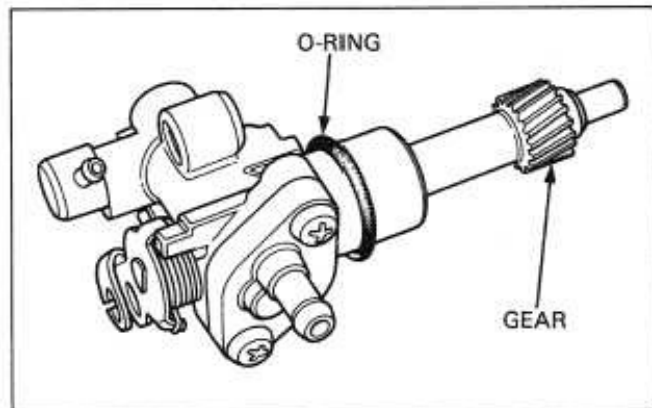

PRESSURE RELIEF VALVE

Remove the snap ring, washer, spring and valve from the valve body.

Check the valve and body for wear, scratches or damage. Check the snap ring groove for damage. If the snap ring groove is damaged, the oil supply will be reduced and the engine may seize.

NOTE

- Install the valve with the open side facing toward the spring.

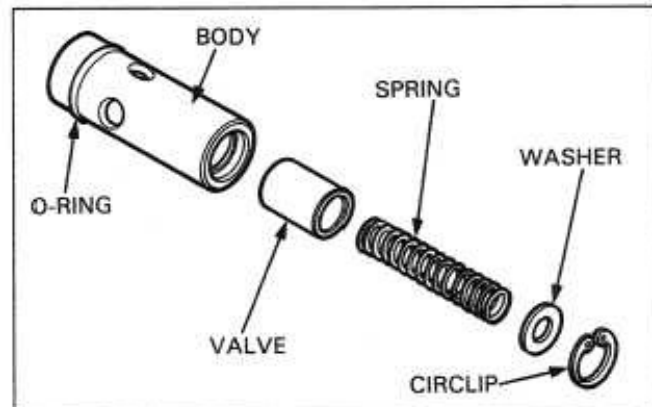

In-Set Type Oil pump

Remove the cotter pin, seat, spring and valve.

Check the valve for wear or damage.

NOTE

- Install the valve with the closed side facing the spring.

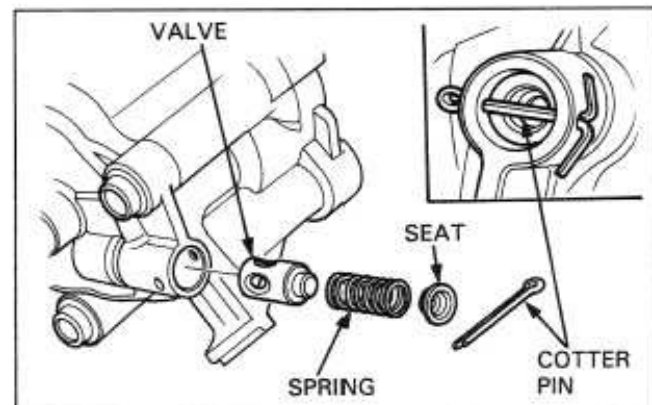

OIL PUMP/OIL LINE BLEEDING (2-STROKE ENGINES)

CAUTION

- Be sure to bleed all air from the oil system. Air in the oil system will block or restrict oil flow and can cause serious engine damage.

NOTE

- Bleed air from the oil suction line and oil pump whenever the oil lines and pump have been removed, there is no oil in the tank, or there is air in the oil lines.
- Bleed air from the oil suction line and pump first, then bleed the oil outlet line.

SUCTION LINE, OIL PUMP BLEEDING

Fill the oil tank with the recommended oil.
Place a shop towel around the oil pump.

Disconnect the oil lines from the oil pump, and fill the pump with oil through the pump outlet.

Let oil drip from the inlet line to expel any air that may be in the line, and then reconnect the suction line to the pump inlet.
If there is a bleed bolt, loosen it until there are no air bubbles in the oil coming out of the bolt hole, then retighten the bleed bolt.

Check that there is no air in the oil line.

Next, bleed air from the oil outlet line.

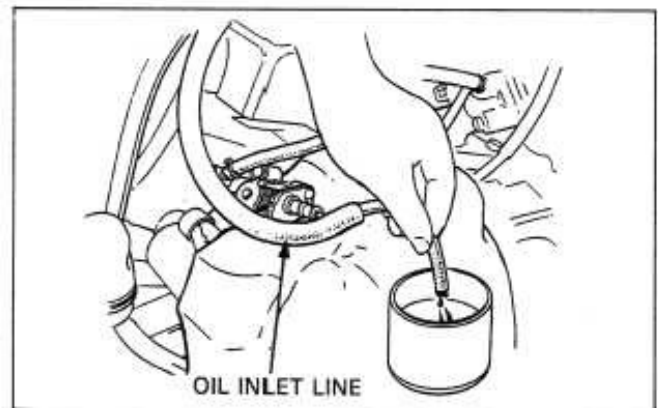
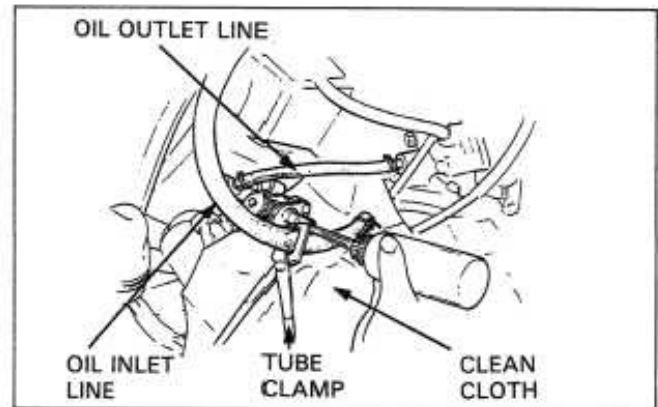

OUTLET LINE BLEEDING

Remove the oil outlet line and close the intake pipe joint.
Bend the oil outlet line into a "U" form with both the ends parallel, and fill the oil outlet line with clean oil.

Connect the oil outlet line to the oil pump joint.

Start the engine and allow it to idle with the oil control lever in the fully open position, making sure that oil is flowing out of the oil outlet line.

⚠ WARNING

- Perform this operation in a well ventilated area. Exhaust contains poisonous carbon monoxide gas that can cause loss of consciousness and may lead to death.

CAUTION

- Run the engine at the lowest necessary rpm level to avoid possible engine damage if oil flow is restricted.

Stop the engine and again bleed air from the oil inlet line and oil pump if oil does not flow out within one minute. Then recheck oil flow.

Connect the oil outlet line to the intake pipe joint.

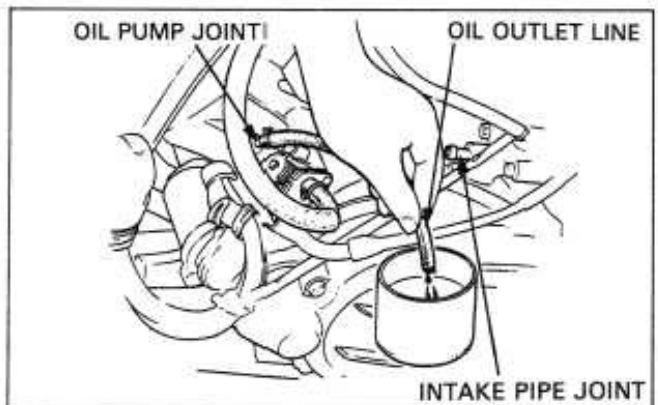
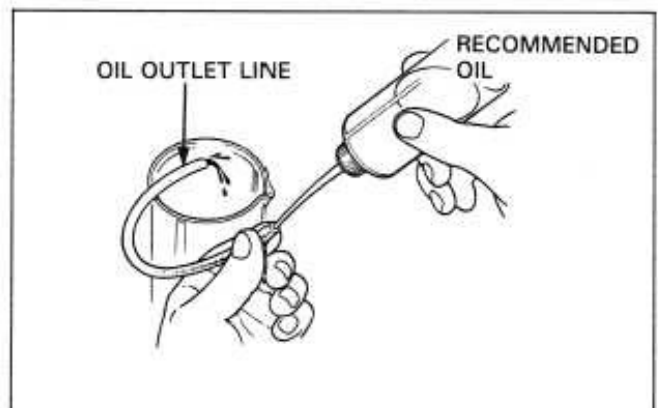

OIL COOLER INSPECTION

Check the oil line connections for leaks.

Check the oil cooler for bent or collapsed fins.
Straighten the bent or collapsed fins with a suitable, small,
blade-type screw driver if necessary.
Check the air passages for clogging or restriction.
Blow dirt out from between core fins with compressed air or
wash off dirt with water.

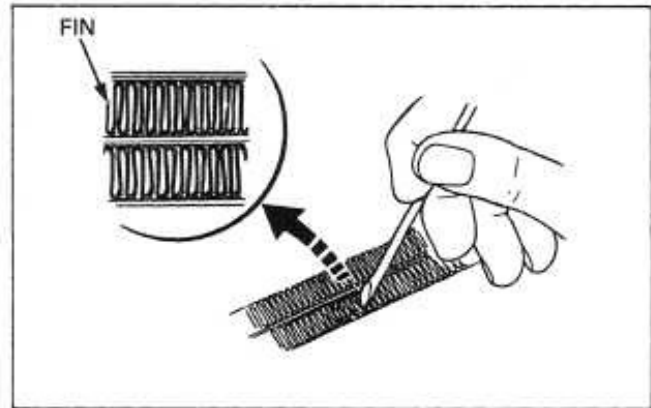

5. COOLING SYSTEM

SERVICE INFORMATION	5-1	SYSTEM TESTING	5-7
TROUBLESHOOTING	5-1	THERMOSTAT	5-8
SYSTEM DESCRIPTIONS	5-2	WATER PUMP	5-8
COOLANT	5-6		

SERVICE INFORMATION

▲ WARNING

- Wait until the engine is cool before slowly removing the radiator cap. Removing the cap while the engine is hot and the coolant is under pressure may cause serious scalding.
- Radiator coolant is toxic. Keep it away from eyes, mouth, skin and clothes.
 - If any coolant gets in your eyes, rinse them with water and consult a doctor immediately.
 - If any coolant is swallowed, induce vomiting, gargle and consult a physician immediately.
 - If any coolant gets on your skin or clothes, rinse thoroughly with plenty of water.
- KEEP OUT OF REACH OF CHILDREN

- Add coolant at the reserve tank. Do not remove the radiator cap except to refill or drain the system.
- All cooling system service can be made with the engine in the frame.
- Avoid spilling coolant on painted surfaces.
- After servicing the system, check for leaks with a cooling system tester.
- Refer to section 25 for fan motor thermostatic switch and temperature sensor inspections.

TROUBLESHOOTING

Engine temperature too high

- Faulty temperature gauge or gauge sensor (see section 25)
- Thermostat stuck closed
- Faulty radiator cap
- Insufficient coolant
- Passages blocked in radiator, hoses, or water jacket
- Air in system
- Faulty cooling fan motor
- Faulty fan motor switch (see section 25)
- Faulty water pump

Engine temperature too low

- Faulty temperature gauge or gauge sensor
- Thermostat stuck open
- Faulty cooling fan motor switch (see section 25)

Coolant leaks

- Faulty pump mechanical seal
- Deteriorated O-rings
- Faulty radiator cap
- Damaged or deteriorated gaskets
- Loose hose connection or clamp
- Damaged or deteriorated hoses

COOLING SYSTEM

SYSTEM DESCRIPTIONS

A liquid cooling system allows optimal engine operating temperature while preventing overheating and overcooling. The coolant is pumped through the system by means of a water pump. Combustion heat is absorbed by the coolant in the course of its passage through the water hoses, water jacket around the cylinder, and through the cylinder head. The coolant then passes into the radiator through the thermostat and upper radiator hose. The hot coolant is cooled by air in the course of its passage through the radiator and is then returned into the water pump through the lower radiator hose.

SYSTEM FLOW PATTERNS

TYPICAL 4-STROKE ENGINE:

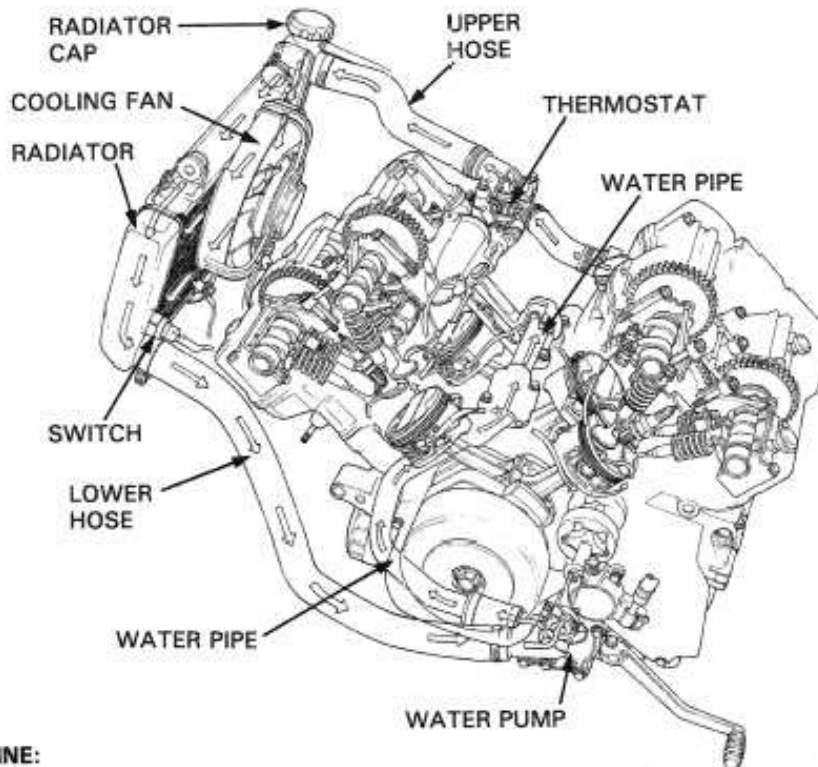

TYPICAL 2-STROKE ENGINE:

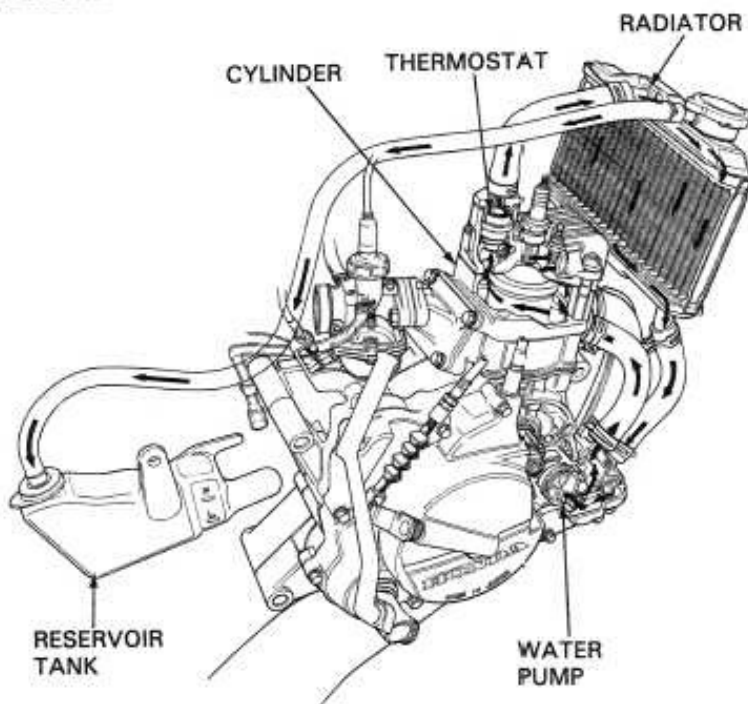

RADIATOR

Coolant temperature is decreased by dissipating heat into the air by means of the radiator fins as the coolant passes through the radiator tube. The larger the fin's surface area, the more the radiator exerts its cooling capacity.

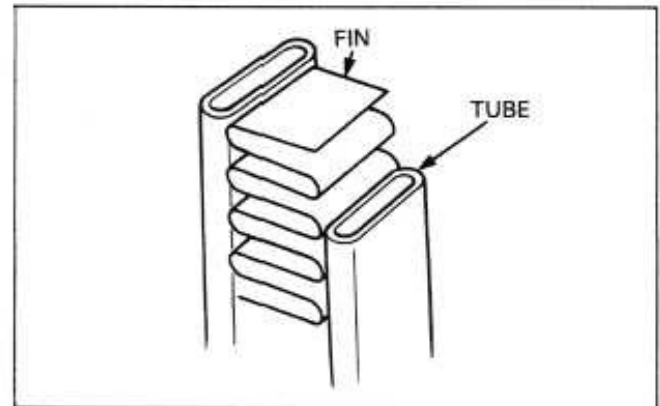

It is important that air is permitted to pass through the radiator fins so that the heat is dissipated from the coolant to the fins and into the atmosphere. Crushed or twisted fins will not permit heat to be dissipated because of inability of the air to pass through them, resulting in lowered cooling capacity. If 1/3 or more of the fins are crushed or twisted, the fins should be repaired using a small flat blade screwdriver.

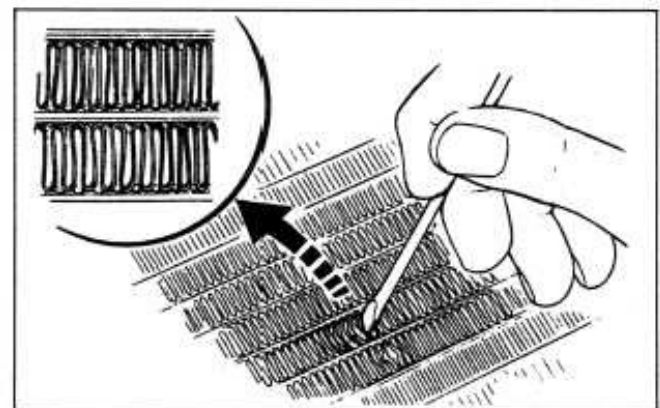

COOLING FAN

Heat is dissipated into the atmosphere because of the difference in temperature between the air and the coolant which has absorbed the heat.

If air around the radiator is stagnant, or when the atmospheric temperature is high, since the temperature difference between the atmosphere and the coolant becomes smaller, heat dissipation is decreased, adversely affecting engine cooling.

A cooling fan maintains the cooling performance under severe conditions. It forces air to flow through the radiator and around the engine to dissipate heat, whether the machine is moving or not.

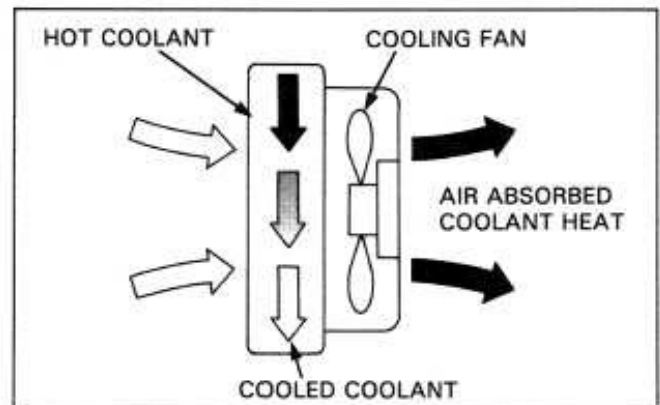

COOLING FAN SWITCH

The fan switch automatically starts or shuts down the cooling fan depending on the temperature of the coolant. While the coolant temperature is low, the fan motor switch is turned OFF. When the coolant temperature rises, the thermo-wax in the switch expands to the switch is turned ON and causes the cooling fan to turn.

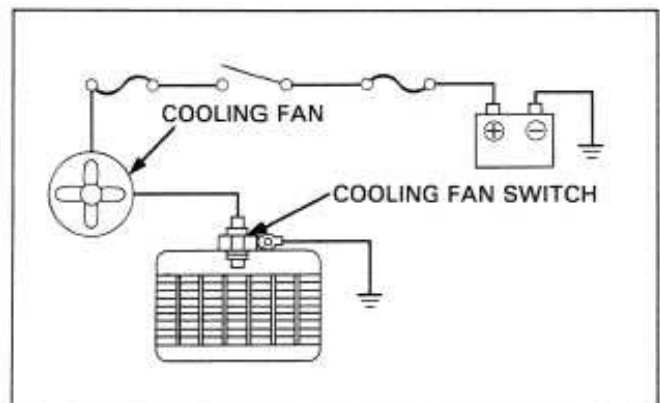

COOLING SYSTEM

RADIATOR CAP

The boiling point of the coolant may be increased by providing a pressure-type cap (hereafter, radiator cap) on the coolant inlet. The radiator cap serves to increase the coolant temperature as well as to retain pressure in the cooling system.

Coolant Boiling Point (Coolant of 50-50 mixture)

Pressure	Boiling Point
0 (Atmospheric pressure)	109°C (228°F) approx.
Under 12.8 psi (0.9 kg/cm ²)	129°C (264°F) approx.
Under 15.7 psi (1.1 kg/cm ²)	131°C (268°F) approx.

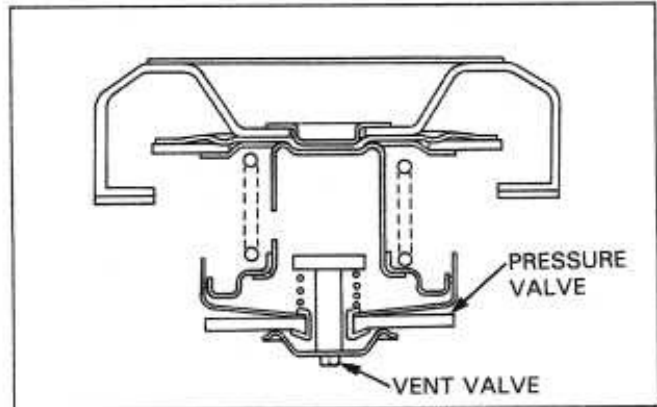

▲ WARNING

- Wait until the engine is cool before slowly removing the radiator cap. Removing the cap while the engine is hot and the coolant is under pressure may cause serious scalding.

As the coolant temperature increases, the difference in temperature between the coolant and atmosphere becomes greater.

Due to the pressurized system, coolant vapor loss is prevented while the cooling effect is enhanced.

The radiator cap is provided with a pressure valve and vent valve which maintain the pressure in the cooling system at a constant level.

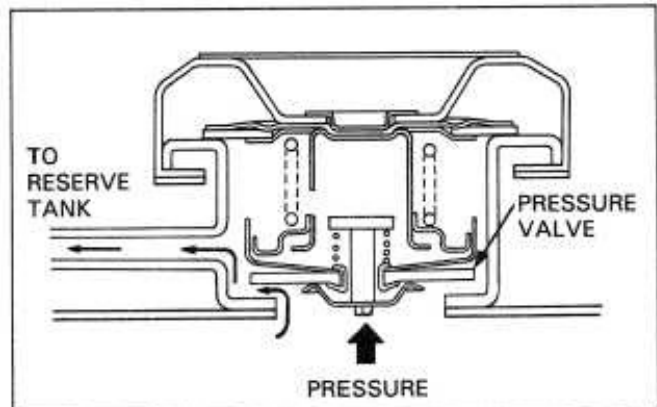

If the pressure in the cooling system is increased due to the increase in coolant temperature, the pressure is kept constant by means of a pressure valve.

If the pressure exceeds the prescribed limit, the pressure valve is opened so that the pressure in the cooling system is regulated by releasing the coolant (whose volume has expanded due to the increase in temperature). The pressure at which the pressure valve begins to open is called the radiator valve opening pressure.

When the coolant temperature is decreased after shutdown of the engine and the cooling system pressure is reduced (with the coolant volume contracted), the vent valve is opened by atmospheric pressure and coolant from the reserve tank flows back into the cooling system.

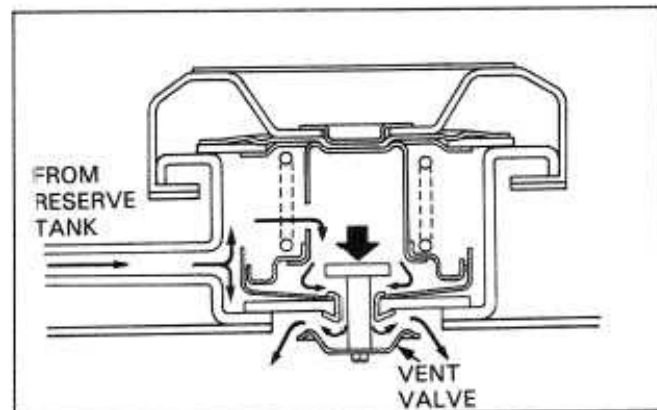

RESERVE TANK

As explained in the preceding paragraph "Radiator Cap", the reserve tank serves to temporarily store the reserve volume of the coolant.

This aids to control the coolant level in the cooling system. The reserve tank is connected to the radiator by means of a siphon tube.

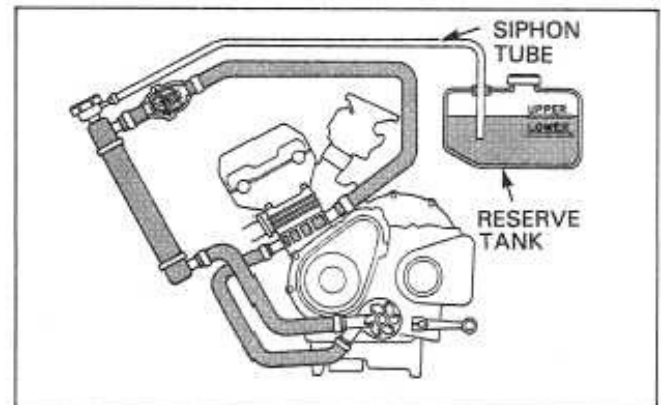

THERMOSTAT

The thermostat is installed between the water jacket of the cylinder head and the radiator.

The thermostat helps warm up the engine by preventing coolant circulation when the temperature of the engine (coolant) is low by closing a valve.

It is an automatic valve designed so that when the engine temperature increases, thermostat wax expands to open the valve, allowing the coolant to circulate through the radiator.

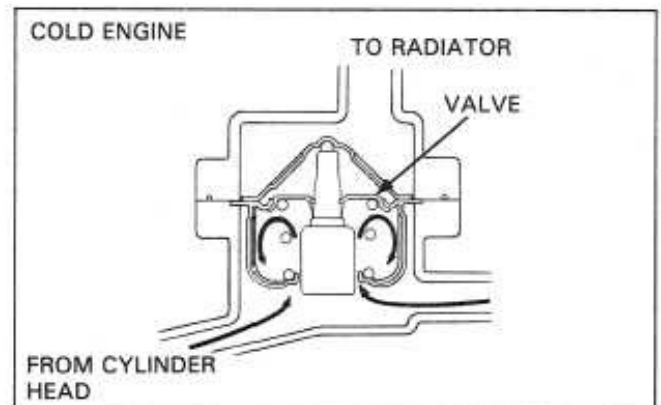

Even if atmospheric temperature varies, the thermostat controls the engine temperature at a constant level.

If the thermostat is stuck open, the coolant circulates even at low temperatures. This prevents optimum engine operating temperature and leads to overcooling.

If the thermostat is stuck closed, it contributes to overheating, since it prevents coolant circulation and prevents the radiator from dissipating the heat if the engine temperature exceeds the critical limit.

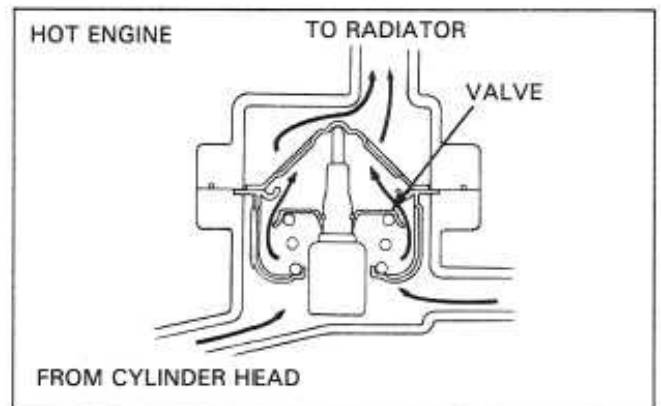

WATER PUMP

The water pump prompts the natural circulation of the coolant in the cooling system, which is carried out by convection. It also feeds the coolant uniformly to the cylinder and cylinder head water jacket so that effective cooling is maintained.

When the impeller turns, centrifugal force draws the coolant through the water pump inlet and discharges it into the engine's water jacket.

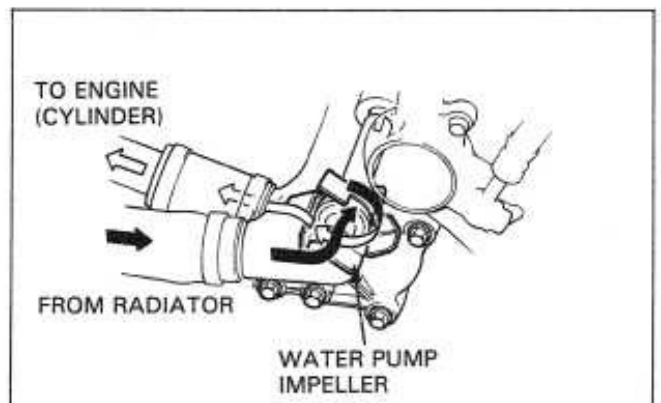

COOLING SYSTEM

COOLANT

PREPARATION

▲ WARNING

- Radiator coolant is toxic. Keep it away from eyes, mouth, skin and clothes.
 - If any coolant gets in your eyes, rinse them with water and consult a doctor immediately.
 - If any coolant is swallowed, induce vomiting, gargle and consult a physician immediately.
 - If any coolant gets on your skin or clothes, rinse thoroughly with plenty of water.
- KEEP OUT OF REACH OF CHILDREN

NOTE

- The effectiveness of coolant decreases with the accumulation of rust or if there is a change in the mixing proportion during usage. Therefore, for best performance change the coolant regularly as specified in the maintenance schedule.
- Use coolant designed for use in aluminum engines (ethylene glycol base solution).
- Mix only distilled water with the antifreeze.

RECOMMENDED MIXTURE:

50/50 (Distilled water and coolant)

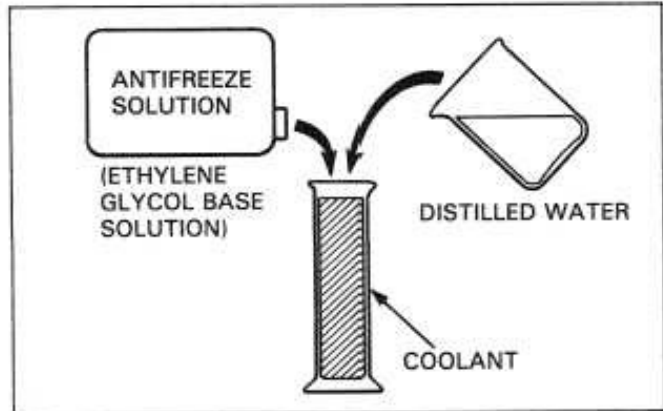

REPLACEMENT

▲ WARNING

- Wait until the engine is cool before servicing the cooling system. Removing the radiator cap while the engine is hot and the coolant is under pressure may cause serious scalding.

Remove the coolant reserve tank. Empty the coolant and rinse the inside of the reserve tank.

Remove the radiator cap and drain bolt(s), and drain the coolant.
Reinstall the drain bolt(s).

Refer to the Model Specific manual for drain bolt locations.

Pour the recommended coolant through the radiator filler opening up to the filler neck.

Reinstall the reserve tank and fill it to the upper level line with fresh coolant.

Bleed air from the system.
Install the radiator cap securely.

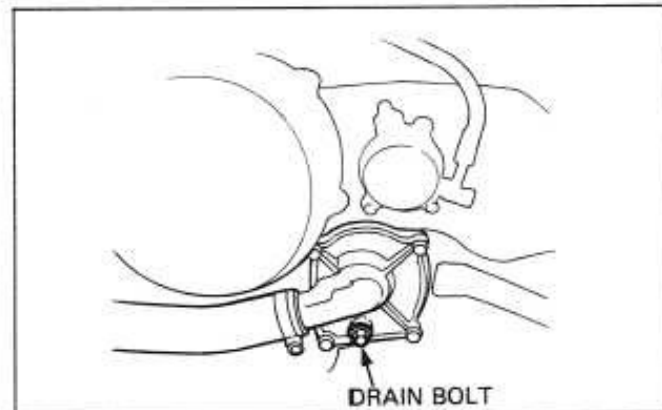
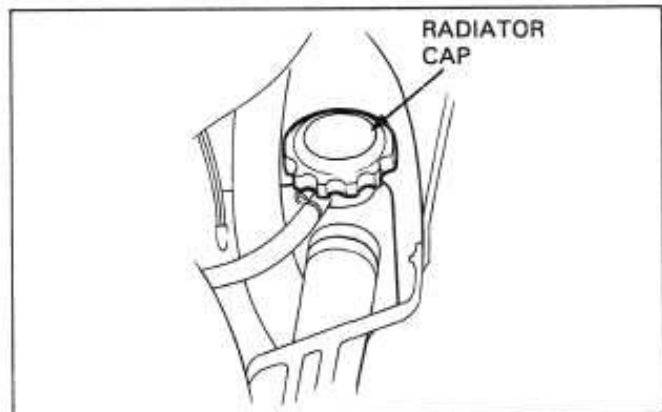

AIR BLEEDING

Shift the transmission into neutral.

Start the engine and snap the throttle 3-4 times to bleed air from the system.

Stop the engine and add coolant up to filler neck.

Install the radiator cap securely.

Check the coolant level of the reserve tank and fill to the upper level if the level is low.

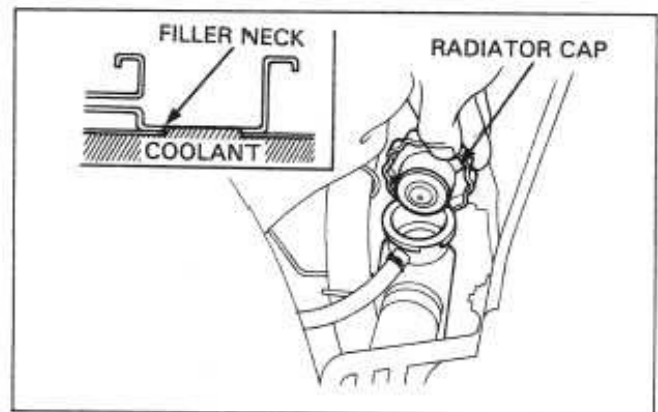

SYSTEM TESTING

HYDROMETER TEST

Check the coolant gravity using a hydrometer. Look for contamination and replace the coolant if necessary.

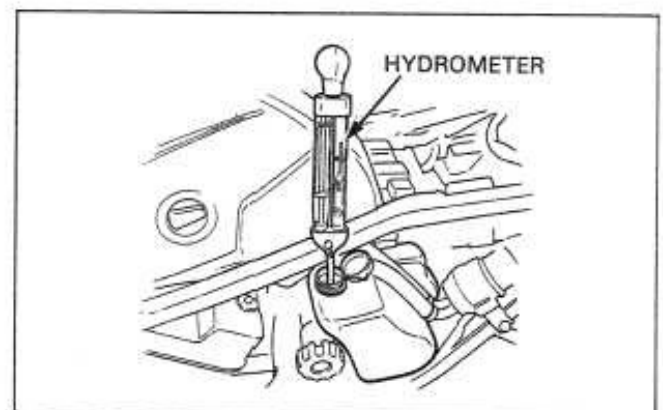

Coolant gravity chart

COOLANT TEMPERATURE °C (°F)	COOLANT RATIO %										
	0 (32)	5 (41)	10 (50)	15 (59)	20 (68)	25 (77)	30 (86)	35 (95)	40 (104)	45 (113)	50 (122)
5	1.009	1.009	1.008	1.008	1.007	1.006	1.005	1.003	1.001	0.999	0.997
10	1.018	1.017	1.017	1.016	1.015	1.014	1.013	1.011	1.009	1.007	1.005
15	1.028	1.027	1.026	1.025	1.024	1.022	1.020	1.018	1.016	1.014	1.012
20	1.036	1.035	1.034	1.033	1.031	1.029	1.027	1.025	1.023	1.021	1.019
25	1.045	1.044	1.043	1.042	1.040	1.038	1.036	1.034	1.031	1.028	1.025
30	1.053	1.052	1.051	1.049	1.047	1.045	1.043	1.041	1.038	1.035	1.032
35	1.063	1.062	1.060	1.058	1.056	1.054	1.052	1.049	1.046	1.043	1.040
40	1.072	1.070	1.068	1.066	1.064	1.062	1.059	1.056	1.053	1.050	1.047
45	1.080	1.078	1.076	1.074	1.072	1.069	1.066	1.063	1.060	1.057	1.054
50	1.086	1.084	1.082	1.080	1.077	1.074	1.071	1.068	1.065	1.062	1.059
55	1.095	1.093	1.091	1.088	1.085	1.082	1.079	1.076	1.073	1.070	1.067
60	1.100	1.098	1.095	1.092	1.089	1.086	1.083	1.080	1.077	1.074	1.071

COOLING SYSTEM

RADIATOR CAP TEST

Test the radiator cap using the cooling system tester.
Replace the cap if the relief pressure is too high or too low, or if the cap does not hold the specified pressure for at least 6 seconds.

NOTE

- Before installing the cap on the tester, wet the sealing surfaces with clean water.

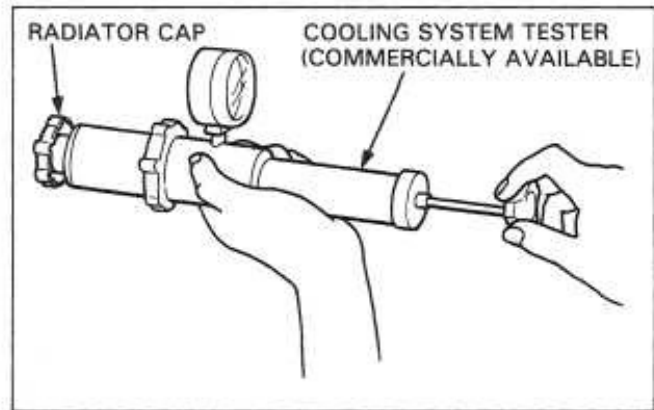

SYSTEM PRESSURE TEST

CAUTION

- Exceeding the radiator cap relief pressure can damage cooling system components.

Check that the system holds the specified pressure for at least 6 seconds.

If the system will not hold the specified pressure, check the following and correct as necessary:

- All hose and pipe connections
- Water pump installation
- Water pump seal (for leakage)
- Deformed radiator filler neck

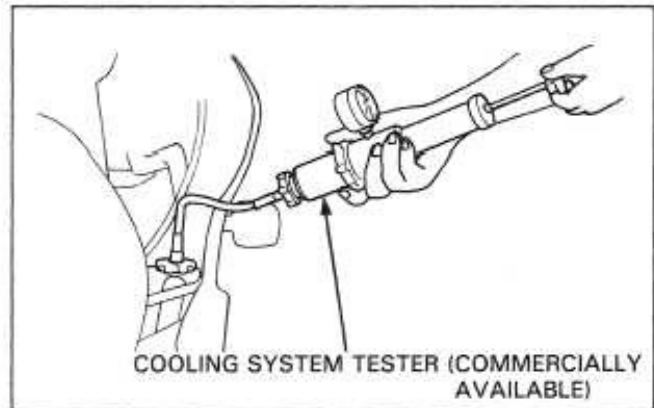

THERMOSTAT

Remove the thermostat (refer to the Model Specific manual).
Inspect the thermostat visually for damage.
Suspend the thermostat in heated water to check its operation.

NOTE

- Do not let the thermostat or thermometer touch the pan, or you will get false readings.
- Replace the thermostat if valve stays open at room temperature, or if it responds at temperatures other than those specified.
- Check for the correct valve lift temperature with the water heated to operating temperature for 5 minutes. Refer to the Model Specific manual for the specific temperature.

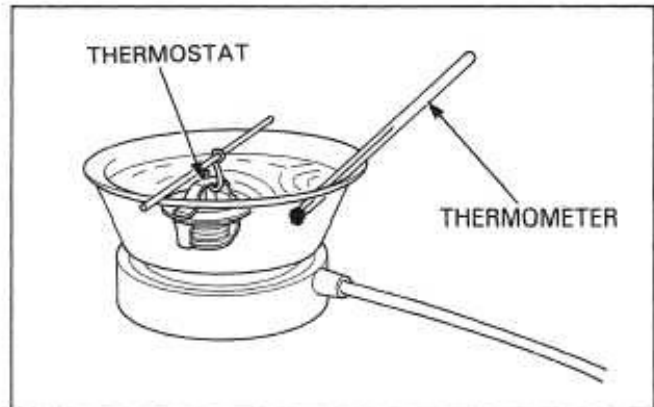

Reinstall the thermostat.

WATER PUMP

MECHANICAL SEAL INSPECTION

Inspect the telltale hole for signs of coolant leakage.
If there is leakage, the mechanical seal is defective and must be replaced.

See the Model Specific manual for mechanical seal replacement procedures.

If the mechanical seal is the built-in type, the water pump must be replaced as an assembly.

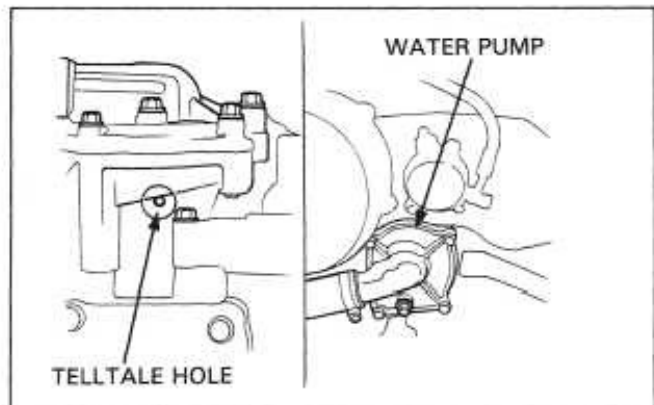

REPLACEMENT

Drain the engine oil and coolant.

Remove the water pump mounting bolts.

Disconnect the water hoses and by-pass tube, then remove the water pump.

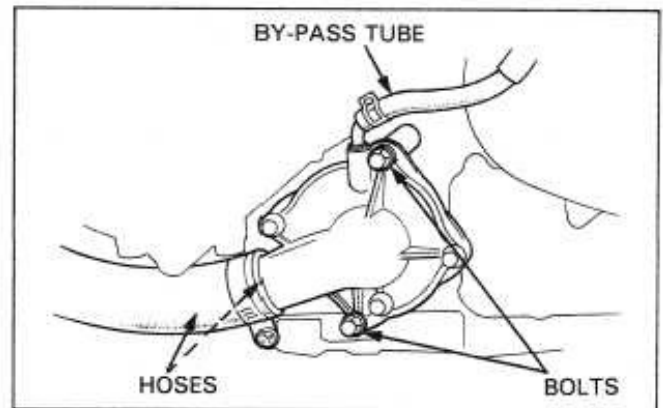

Remove the bolts and separate the pump cover from the body.

Replace the water pump with a new one.

Install a new O-ring into the groove in the pump cover, then install the cover on the pump.

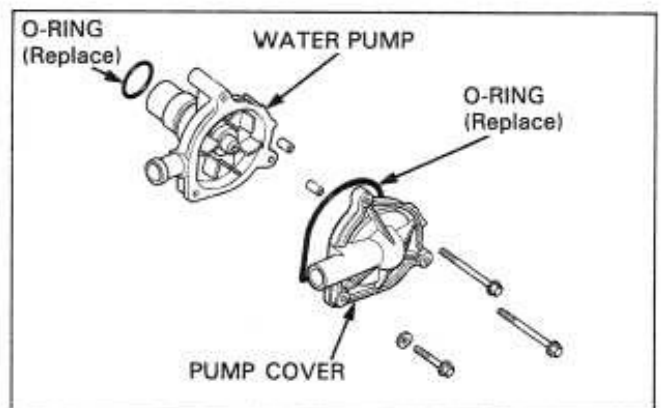

Install a new O-ring onto the water pump, and oil the O-ring.

Align the water pump shaft groove with the water pump drive shaft and install the water pump.

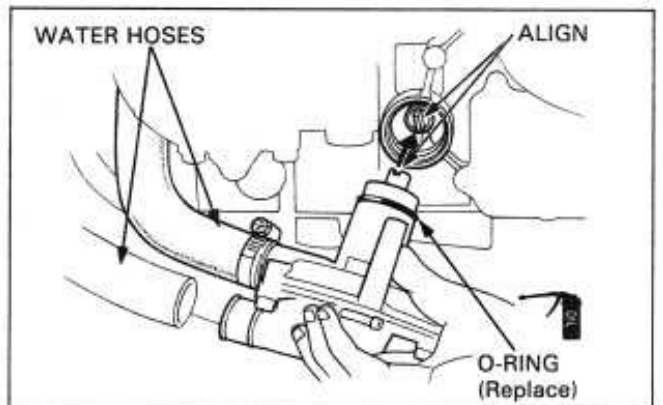

Tighten the pump mounting bolts.

Connect the water hoses and secure the bands and clamp.

Fill the cooling system with coolant and add the recommended engine oil to the engine (see maintenance section).

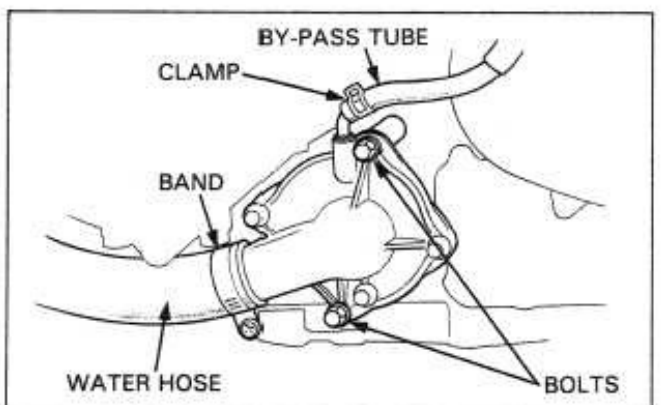

MEMO

6. EXHAUST SYSTEM

SERVICE INFORMATION	6-1	SYSTEM DESCRIPTION	6-2
TROUBLESHOOTING	6-1		

SERVICE INFORMATION

6

▲ WARNING

- Serious burns may result if the exhaust system is not allowed to cool before components are removed or serviced.

- Always replace the exhaust pipe gasket when removing the exhaust pipe from the engine.
- Note the positions of the clamps installed between the exhaust pipe and muffler, the tab on the clamp should align with the groove on the muffler.
- When installing the exhaust system, install all the fasteners loosely. Always tighten the exhaust clamp nut first, then tighten the mounting fasteners. If you tighten the mounting fasteners first, the exhaust pipe may not seat properly.
- Always inspect the exhaust system for leaks after installation.

TROUBLESHOOTING

Excessive exhaust noise

- Broken exhaust system
- Exhaust gas leaks

Poor performance

- Deformed exhaust system
- Exhaust gas leaks
- Clogged muffler

SYSTEM DESCRIPTIONS

The exhaust system serves another functions in addition to discharging the exhaust gas.

Since the exhaust gas discharged from the exhaust port is pressurized and very hot, it swells suddenly and produces a loud noise if it is discharged from the exhaust port directly into the atmosphere. It also lowers the exhaust efficiency as the gas is diffused from the exhaust port. To prevent the above problems, the exhaust gas is drawn from the exhaust port into the muffler to be swelled and is discharged into the atmosphere after its temperature and pressure are lowered. By varying the sizes and diameters of sections of the exhaust system, the air/fuel mixture can be drawn into the cylinder more effectively. This is called the EXHAUST PULSE SCAVENGE EFFECT. Utilizing this effect in exhaust system design results in significant improvements in engine performance, especially on 2-stroke engines.

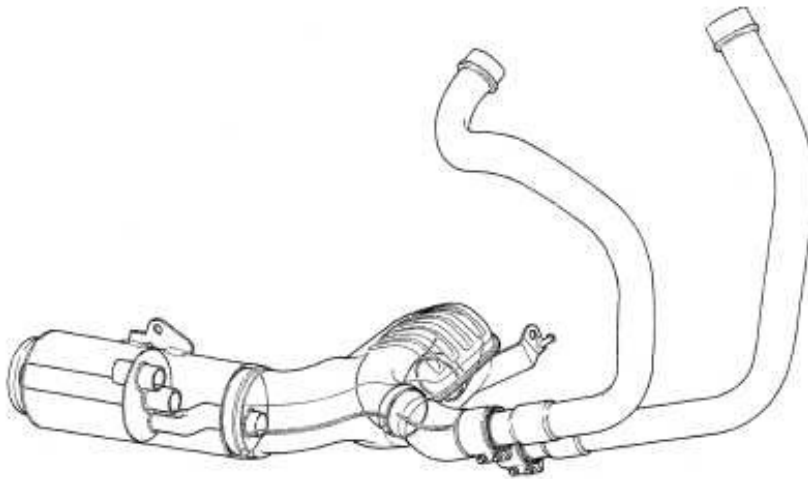

EXHAUST PULSE SCAVENGE EFFECT

When the exhaust valve (or port) opens with the engine on the exhaust stroke, the exhaust gas flows rapidly from the exhaust port into the muffler. At the end of the exhaust stroke, the gas flow slows down, but due to the inertia of liquid mass, pressure in the cylinder goes down below the atmospheric pressure; in other words, negative pressure is applied to the cylinder for a short time. As the intake valve (or scavenge port) opens, the air/fuel mixture quickly drawn into the cylinder.

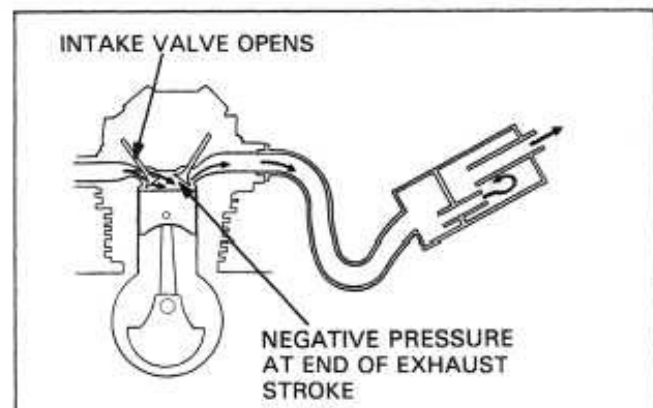

The discharged gas flows through the muffler forming a high speed pressure wave. Due to the inertia of liquid mass, negative pressure is applied to the exhaust port where the pressure wave had passed. When the exhaust valve (or port) opens on the next exhaust stroke, the exhaust gas is drawn out by the negative pressure, and the exhaust efficiency is improved.

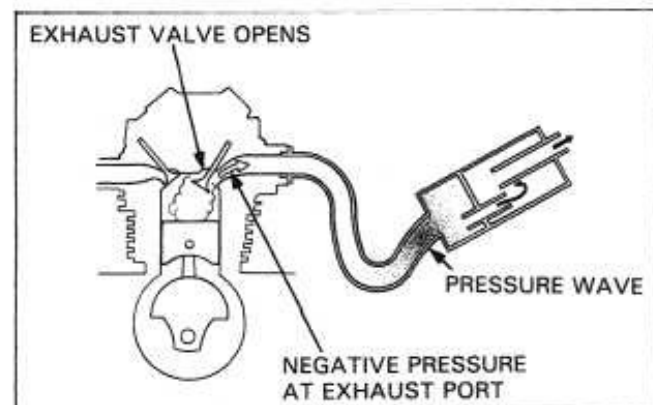

On 2-stroke engines, there is the possibility that the air/fuel mixture that was scavenged just before the end of the exhaust stroke may leak out to some degree and be discharged into the exhaust port.

The gas is discharged into the muffler, forming a high pressure wave. This pressure wave impacts against the taper at the end of the muffler, rebounds, and applies a positive pressure to the exhaust port. The air/fuel mixture that was about to be discharged before the exhaust port closes is thus forced back into the cylinder and the exhaust pulse scavenge effect is improved.

Since the pressure wave cycle changes in accordance with the change in engine speed, the exhaust pulse scavenge effect is not always as effective as it could be at all engine speeds.

The exhaust pulse scavenge effect is regulated to a certain range of engine speed. Therefore, the exhaust system is designed to be most effective and most suitable for each model, depending on its intended use.

Note that if the exhaust system is deformed due to denting or exhaust gas leakage, it can effect the exhaust pulse and result in a drop in engine horsepower.

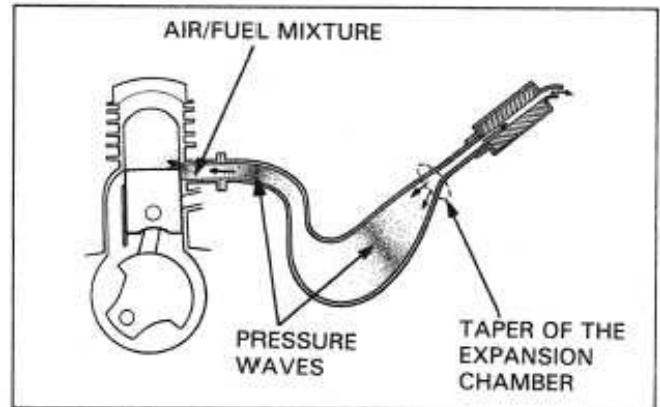

COMMON EXHAUST PIPE

The muffler of the conventional 4-stroke multicylinder engine uses an independent pipe for each cylinder, but most recent models adopt a common exhaust pipe for all cylinders.

The new system features a system in which the exhaust pipes join in the exhaust chamber, and another in which the exhaust pipes are directly joined. In both systems gas pressures exhausted from individual cylinders intermingle. The pulse wave in the muffler, generated by the staggered combustion in adjoining cylinders, promotes the "pulse scavenge effect", which increases exhaust energy absorption and reduces exhaust noise effectively. The resulting smaller muffler has a decreased capacity and increased silencing capability, due to the reduced weight and decreased volume.

The method of exhaust pipe connection depends on the cylinder arrangement or the required engine characteristics. For example, an inline four cylinder engine can be connected with "4-into-1" system or "4-2-1" system etc.

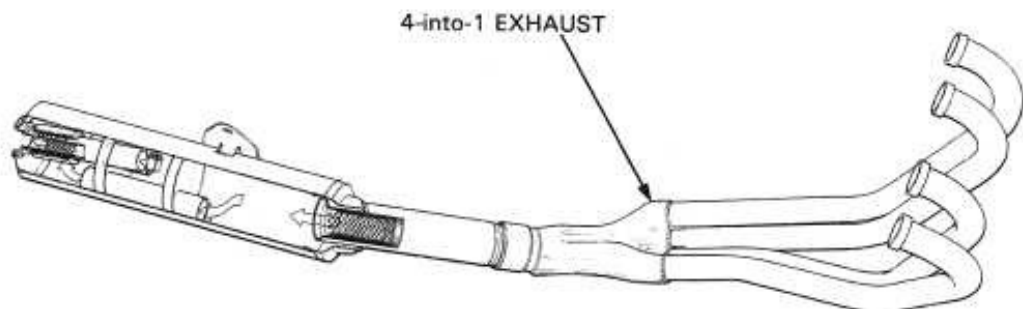

MEMO

7. EMISSION CONTROL SYSTEMS

SERVICE INFORMATION	7-1	SYSTEM INSPECTIONS	7-5
TROUBLESHOOTING	7-1	EMISSION CONTROL INFORMATION LABELS	7-9
SYSTEM DESCRIPTIONS	7-2		

SERVICE INFORMATION

CAUTION

- To prevent damage, be sure to remove the diaphragms before cleaning air and fuel passages with compressed air.

- All hoses used in the pulse secondary air supply and evaporative emission control systems are numbered for identification. When connecting one of these hoses, compare the hose number with the Vacuum Hose Routing Diagram Label (Refer to the Model Specific manual).
- Refer to the Model Specific manual for emission control system application.

TROUBLESHOOTING

Engine stalls, hard to start, rough idling

- Evaporative emission purge control valve (EVAP purge control valve) faulty
- Evaporative emission carburetor air vent control valve (EVAP CAV control valve) faulty
- Hoses in the emission control system faulty

Afterburn when engine braking is used

- Pulse secondary air supply system faulty
- Hoses in emission control system faulty

Poor performance (driveability) and poor fuel economy

- Faulty evaporative emission carburetor air vent control valve (EVAP CAV control valve)
- Damaged/misconnected emission control system hoses

EMISSION CONTROL SYSTEMS

SYSTEM DESCRIPTIONS

The U.S. Environmental Protection Agency and California Air Resources Board (CARB) require manufacturers to certify that their motorcycles comply with applicable exhaust emissions standards during their useful life, when operated and maintained according to the instructions provided, and that motorcycles built after January 1, 1983 comply with applicable noise emission standards for one year or 6,000 km (3,730 miles) after the time of sale to the ultimate purchaser, when operated and maintained according to the instructions provided. Compliance with the terms of the Distributor's Warranties for Honda Motorcycle Emission Control Systems is necessary in order to keep the emissions system warranty in effect.

SOURCE OF EMISSIONS

The combustion process produces carbon monoxide and hydrocarbons. Control of hydrocarbons is very important because, under certain conditions, they react to form photochemical smog when subjected to sunlight. Carbon monoxide does not react in the same way, but it is toxic.

Honda Motor Co., Ltd. utilizes lean carburetor settings as well as emission control systems, to reduce carbon monoxide and hydrocarbons.

CRANKCASE EMISSION CONTROL SYSTEM

The crankcase emission control system routes crankcase emissions through the air cleaner and into the combustion chamber. Condensed crankcase vapors are accumulated in an air/oil separator and crankcase breather tube which must be emptied periodically. Refer to the Maintenance Schedule for each model. The crankcase breather tube needs to be checked for oil accumulation more frequently if the machine has been consistently ridden at high speeds or in rain.

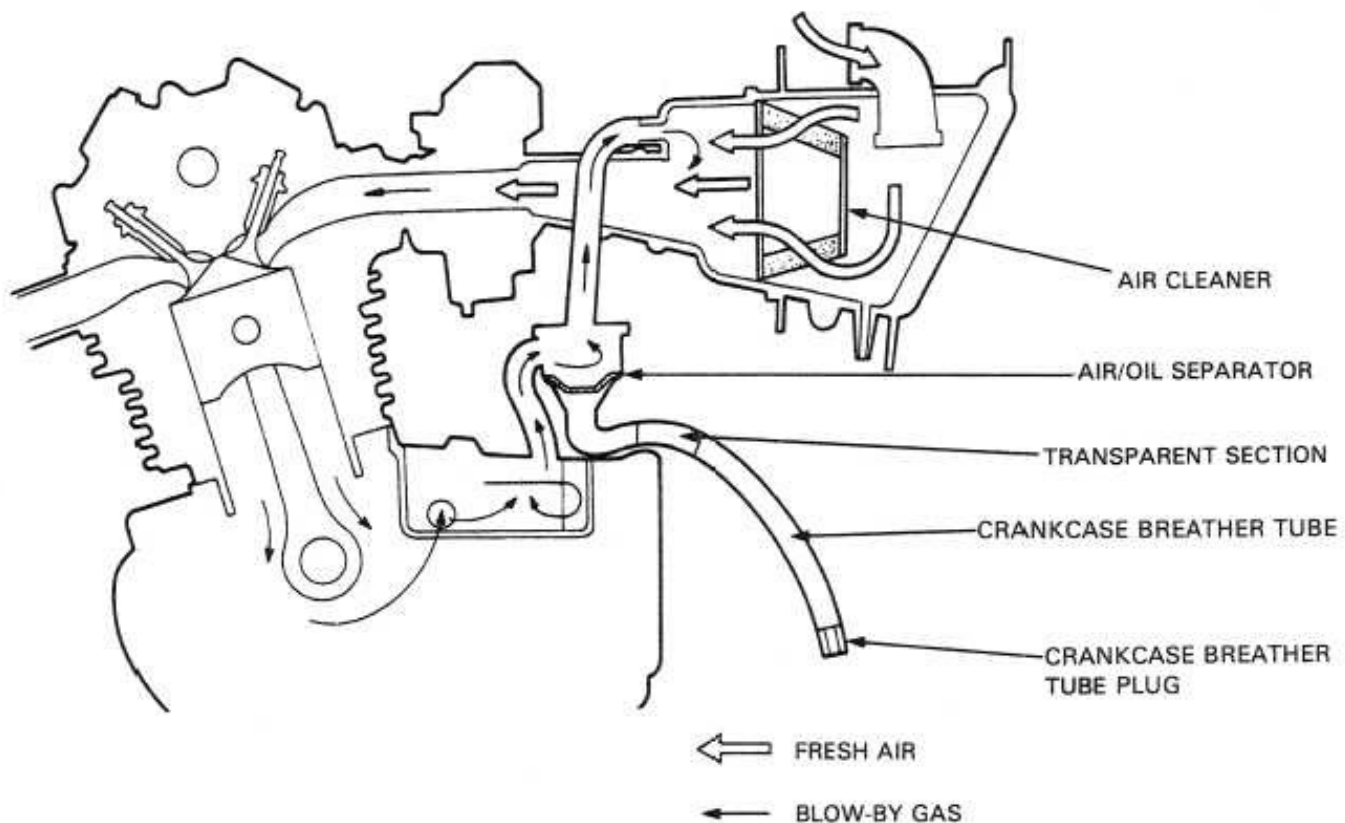

EXHAUST EMISSION CONTROL SYSTEM (PULSE SECONDARY AIR SUPPLY SYSTEM)

The exhaust emission control system is composed of lean carburetor settings and no adjustment should be made except idle speed adjustment with the throttle stop screw.

On some models the exhaust emission control system also consists of a pulse secondary air supply system which introduces filtered air into the exhaust gases in the exhaust port. Fresh air is drawn into the exhaust port whenever there is a negative pressure pulse in the exhaust system. This charge of fresh air promotes burning of the unburned exhaust gases and changes a considerable amount of hydrocarbons and carbon monoxide into relatively harmless carbon dioxide and water.

A pulse secondary air injection check valve (PAIR check valve) prevents reverse air flow through the system. The pulse secondary air injection control valve (PAIR control valve) reacts to high intake manifold vacuum and will cut off the supply of fresh air during engine deceleration, thereby preventing afterburn in the exhaust system.

No adjustments to the secondary air supply system should be made, although periodic inspection of the components is recommended.

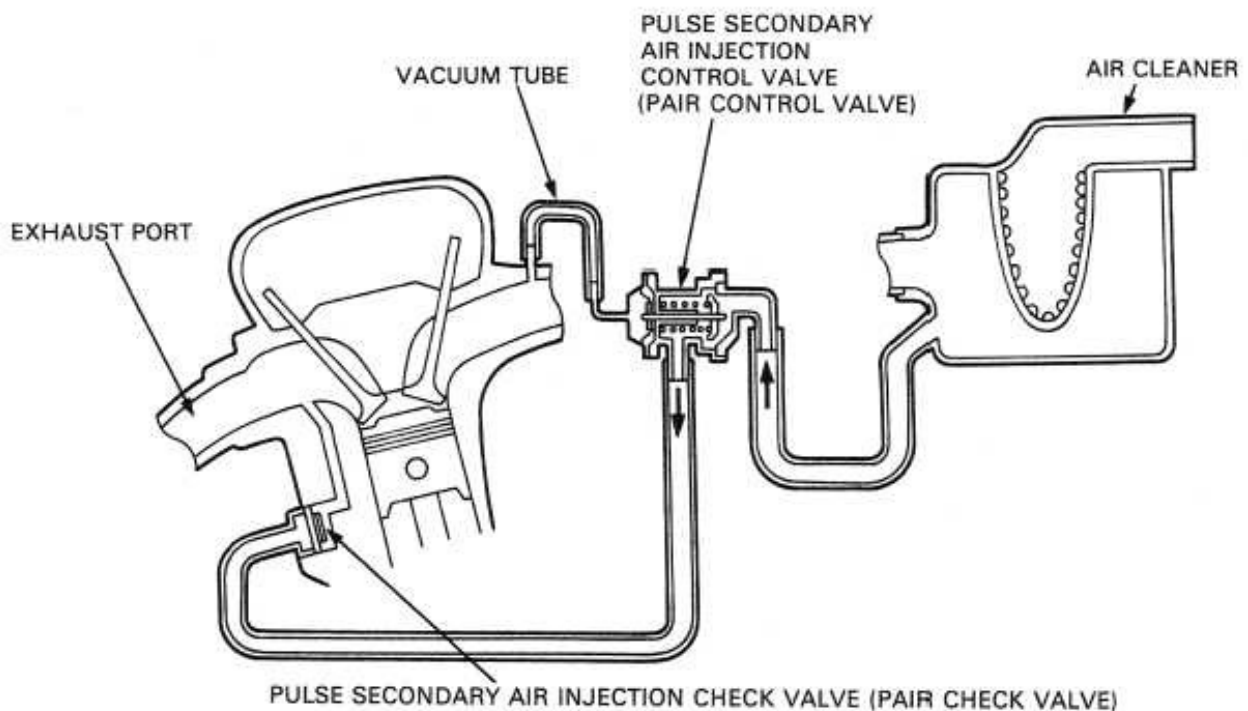

EMISSION CONTROL SYSTEMS

EVAPORATIVE EMISSION (EVAP) CONTROL SYSTEM (California model only)

All Honda motorcycles and scooters sold in California for street use comply with the California Air Resources Board requirements for evaporative emission regulations.

Fuel vapor from the fuel tank and carburetors is routed into the evaporative emission canister (EVAP canister) where it is absorbed and stored while the engine is stopped. When the engine is running and the evaporative emission purge control valve (EVAP purge control valve) is open fuel vapor in the EVAP canister is drawn into the engine through the carburetor. At the same time, the evaporative emission carburetor air vent control valve (EVAP CAV control valve) is open and air is drawn into the carburetor through the valve.

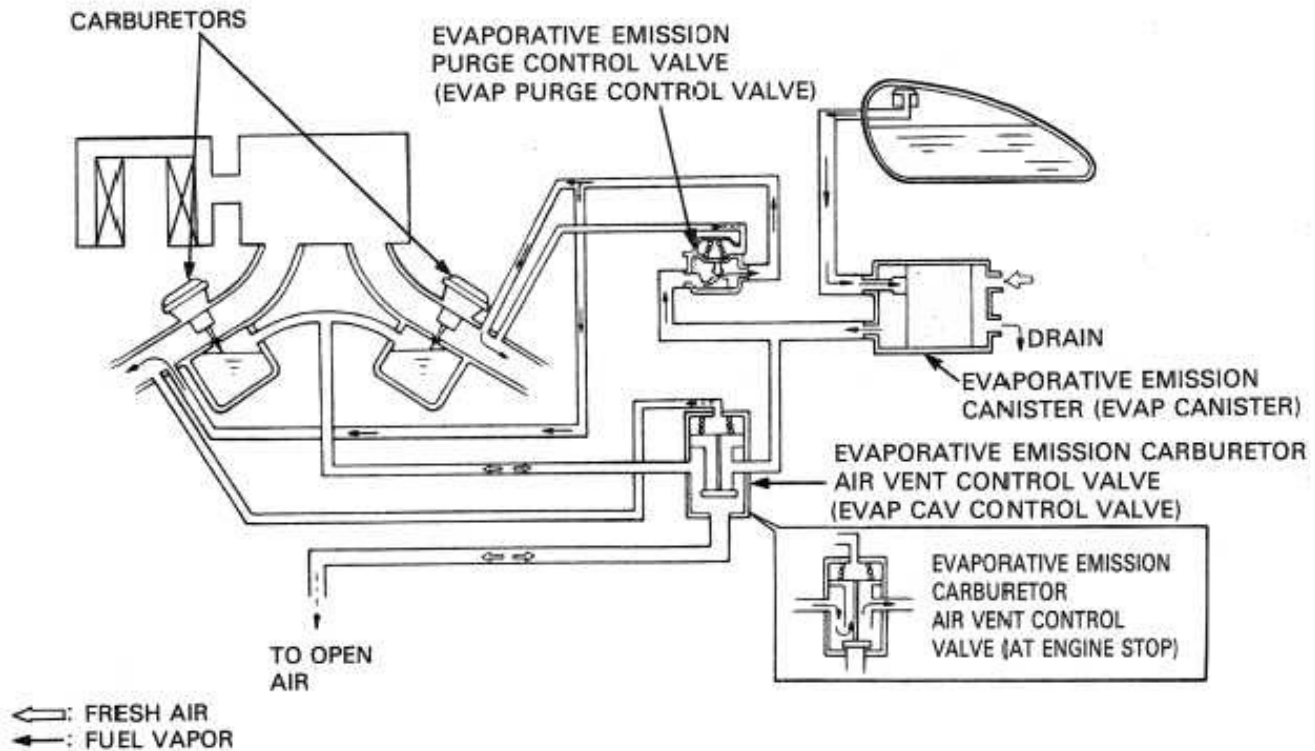

NOISE EMISSION CONTROL SYSTEM

TAMPERING WITH THE NOISE CONTROL SYSTEM IS PROHIBITED: Federal law prohibits the following acts or the causing thereof: (1) The removal or rendering inoperative by any person, other than for purposes of maintenance, repair or replacement, of any device or element of design incorporated into any new vehicle for the purpose of noise control prior to its sale or delivery to the ultimate purchaser or while it is in use; or (2) the use of the vehicle after such device or element of design has been removed or rendered inoperative by any person.

AMONG THOSE ACTS PRESUMED TO CONSTITUTE TAMPERING ARE THE ACTS LISTED BELOW:

1. Removal of, or puncturing the muffler, baffles, header pipes or any other component which conducts exhaust gases.
2. Removal of, or puncturing of any part of the intake system.
3. Lack of proper maintenance.
4. Replacing any moving parts of the vehicle, or parts of the exhaust or intake system, with parts other than those specified by the manufacturer.

SYSTEM INSPECTION

EVAPORATIVE EMISSION CONTROL SYSTEM (California model only)

Check the system hoses for deterioration, clogging, damage, and loose joints and connections.

Replace any hose that shows signs of damage or deterioration.

Check the evaporative emission canister for cracks or damage.

EVAPORATIVE EMISSION PURGE CONTROL VALVE (EVAP PURGE CONTROL VALVE)

NOTE

- The evaporative emission purge control valve should be inspected if hot restart is difficult.

Disconnect the EVAP purge control valve hoses from their connections and remove the EVAP purge control valve from its mount. Refer to the vacuum hose routing diagram label for hose connections.

Connect a vacuum pump to the hose that goes to the vacuum tube fitting.

Apply the specified vacuum to the EVAP purge control valve.



VACUUM PUMP

ST-AH-260-MC7
(U.S.A. only)

SPECIFIED VACUUM: 250 mm (9.8 in) Hg

The specified vacuum should be maintained. Replace the EVAP purge control valve if vacuum is not maintained.

Remove the vacuum pump and connect it to the hosefitting (EVAP output port) that goes to the carburetor(s).

NOTE

- If the EVAP purge control valve has two hose fittings that go to the carburetor(s), connect the blocked tube onto the other fitting to prevent air leaks.

Apply the specified vacuum to the EVAP purge control valve.

SPECIFIED VACUUM: 250 mm (9.8 in) Hg

The specified vacuum should be maintained. Replace the EVAP purge control valve if vacuum is not maintained.

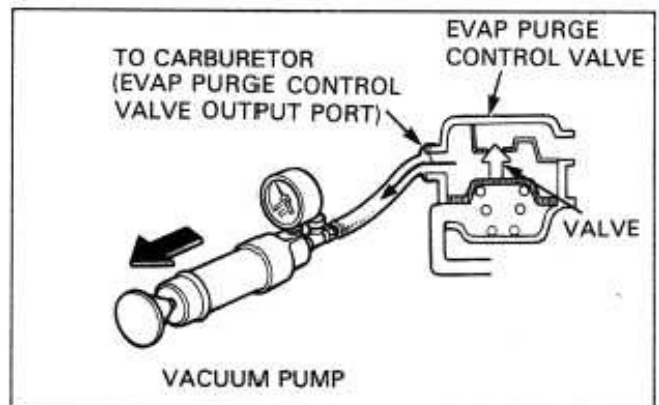
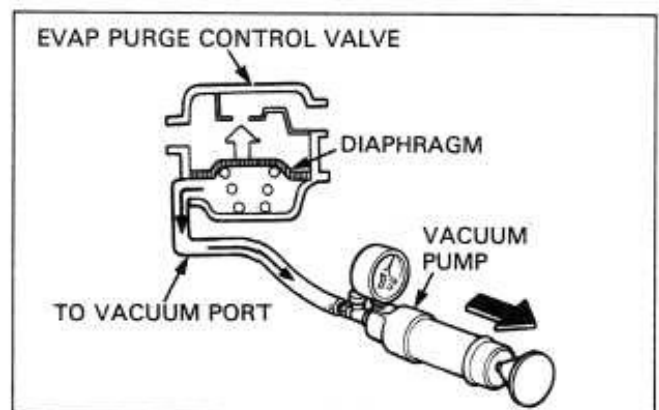

EMISSION CONTROL SYSTEMS

Connect a pressure pump to the hose fitting that goes to the EVAP canister.

NOTE

- If the EVAP purge control valve has two hose fittings that go to the charcoal EVAP canister, connect the blocked tube onto the other fitting to prevent air leaks.

While applying the specified vacuum to the EVAP purge control valve hose that goes to the vacuum port, pump air through the EVAP canister hose. Air should flow through the EVAP purge control valve and out the hose that goes to the carburetor. Replace the EVAP purge control valve if air does not flow out.

S TOOL

PRESSURE PUMP

ST-AH-255-MC7
(U.S.A. only)

CAUTION

- Damage to the EVAP purge control valve may result from use of a high pressure air source. Use a hand-operated air pump only.

Remove the pump, install the EVAP purge control valve on its mount, route and reconnect the hoses according to the vacuum hose routing diagram label.

EVAPORATIVE EMISSION CARBURETOR AIR VENT CONTROL VALVE (EVAP CAV CONTROL VALVE)

NOTE

- The EVAP CAV control valve should be inspected if engine restart is difficult.

Disconnect the EVAP CAV control valve hoses from their connections and remove the EVAP CAV control valve from its mount. Refer to the vacuum hose routing diagram label for hose connections.

Connect a vacuum pump to the hose that goes to the vacuum tube fitting.

S TOOL

VACUUM PUMP

ST-AH-260-MC7

Apply the specified vacuum to the EVAP CAV control valve.

SPECIFIED VACUUM: 250mm (9.8 in) HG

The specified vacuum should be maintained. Replace the EVAP CAV control valve if vacuum is not maintained.

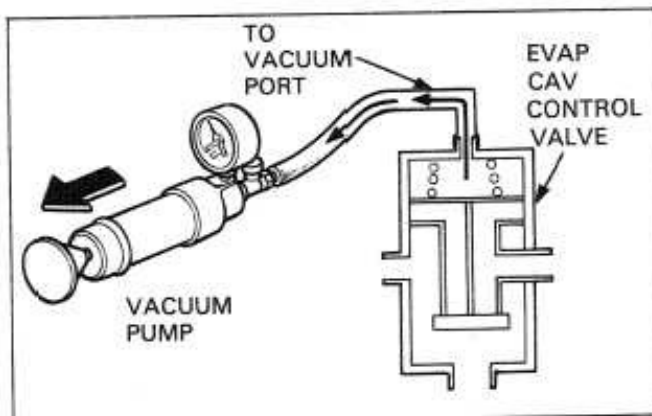
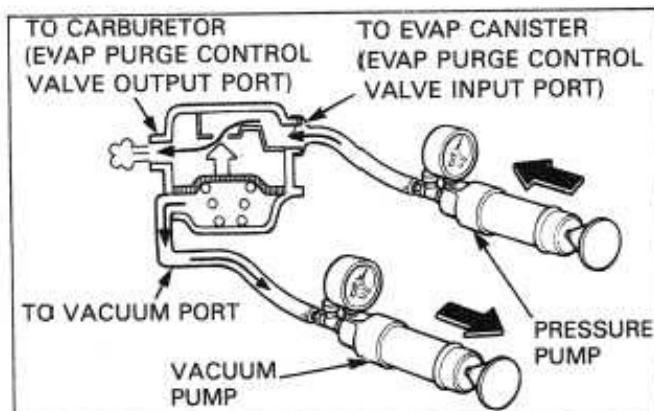

Connect the vacuum pump to the air vent fitting on the EVAP CAV control valve that goes to open air.

NOTE

- If the EVAP CAV control valve has two hose fittings that go to open air, connect the blocked tube onto the other fitting to prevent air leaks.

Apply vacuum to the EVAP CAV control valve. The vacuum should hold steady. Replace the EVAP CAV control valve if vacuum leaks.

Connect the vacuum pump to the hose that goes to the vacuum tube fitting.

S. TOOL

VACUUM PUMP

ST-AH-260-MC7
(U.S.A. only)

Connect the pressure pump to the air vent fitting on the EVAP CAV control valve that goes to open air.

S. TOOL

PRESSURE PUMP

ST-AH-255-MC7
(U.S.A. only)

NOTE

- If the EVAP CAV control valve has two hose fittings that go to open air, connect the blocked tube onto the other fitting to prevent air leaks.

While applying the vacuum to the EVAP CAV control valve hose that goes to the vacuum tube fitting, pump air through the air vent fitting. Air should flow through the EVAP CAV control valve and out the hose that goes to the carburetor.

CAUTION

- **Damage to the EVAP CAV control valve may result from use of a high pressure air source. Use a hand-operated air pump only.**

Plug the hose that goes to the carburetor.

NOTE

- If the EVAP CAV control valve has two hose fittings that go to open air, connect the blocked tube onto the other fitting to prevent air leaks.

While applying vacuum to the EVAP CAV control valve hose that goes to the vacuum tube fitting, apply air pressure to the air vent fitting.

It should hold steady.

Replace the EVAP CAV control valve if pressure is not retained.

Remove the pumps, install the EVAP purge control valve on its mount, route and reconnect the hoses according to the vacuum hose routing diagram label.

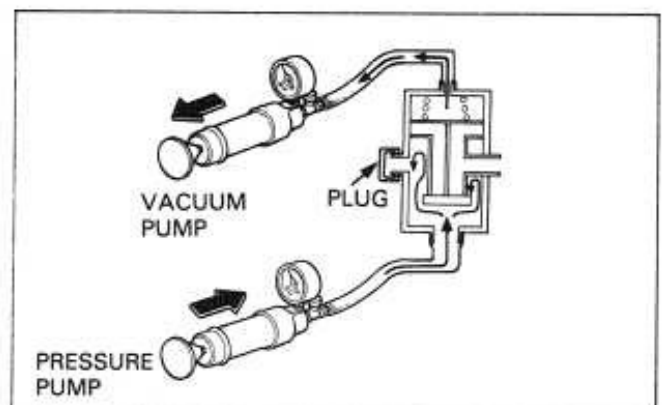
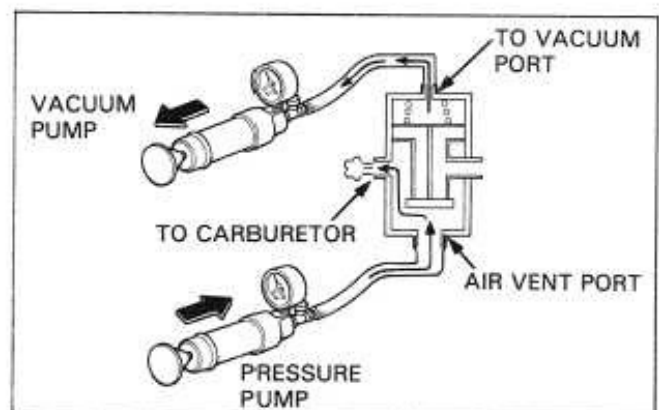
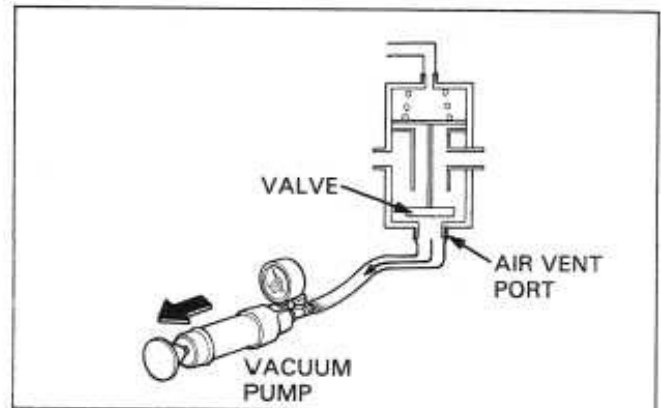

EMISSION CONTROL SYSTEMS

PULSE SECONDARY AIR SUPPLY (PAIR) SYSTEM

Start the engine and warm it up to operating temperature.

Stop the engine and remove the air cleaner element.

Check that the PAIR intake ports are clean and free of carbon deposits.

Check the PAIR check valve in the secondary air passage if the ports are carbon fouled.

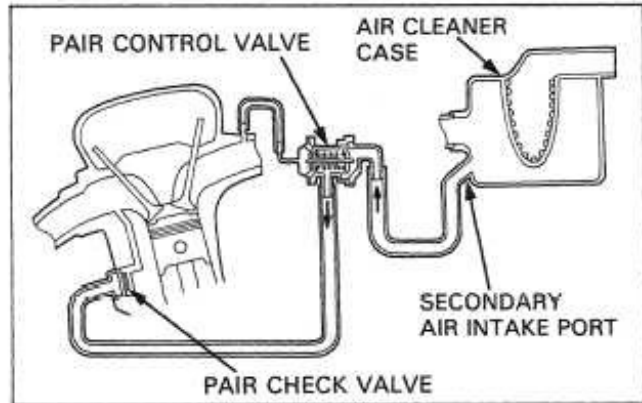

Disconnect the air cleaner-to-pulse secondary air injection control valve hose from the air cleaner housing.

Remove the vacuum tube from the carburetor intake pipe; install a plug to keep air from entering. Connect a vacuum pump to the vacuum hose.

S TOOL

VACUUM PUMP

ST-AH-260-MC7
(U.S.A. only)

Start the engine and open the throttle slightly to be certain that air is sucked in through the air cleaner-to-PAIR control valve hose.

If air is not drawn in, check the air cleaner-to-PAIR control valve hose and vacuum hose for clogging.

With the engine running, gradually apply vacuum to the vacuum hose.

Check that the air intake port stops drawing air, and that the vacuum does not bleed.

SPECIFIED VACUUM: Refer to the Model Specific manual.

If air is still drawn in, or if the specified vacuum is not maintained, install a new PAIR control valve.

If afterburn occurs on deceleration, even when the secondary air supply system is normal, check the slow air cutoff valve for correct vacuum operation.

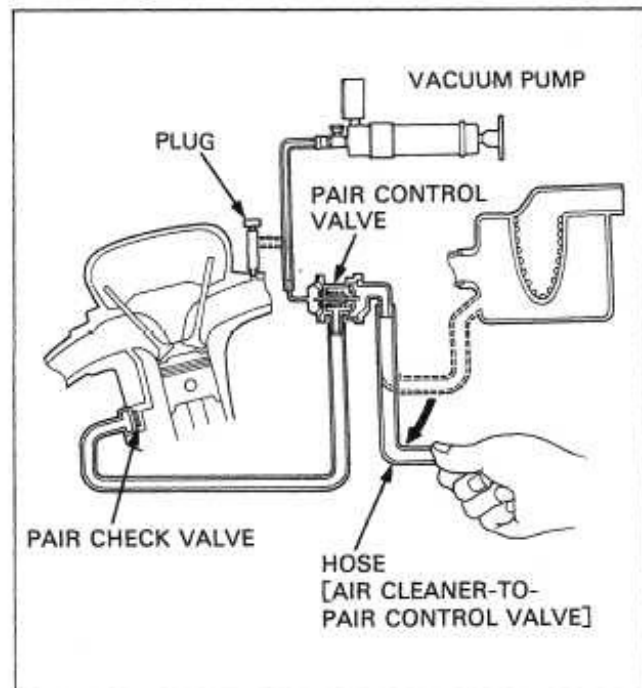

PULSE SECONDARY AIR INJECTION CHECK VALVE (PAIR CHECK VALVE)

NOTE

- Certain types of secondary air supply systems have the reed valve built in the PAIR control valve. Refer to the Model Specific manual for PAIR check valve location.

Remove the PAIR check valve covers and PAIR check valves.

Check the PAIR check valves for damage or fatigue, and replace if necessary.

Install a new PAIR check valve if the seat rubber is cracked or damaged, or if there is clearance between the reed and seat.

CAUTION

- **Disassembling or bending the reed stopper or PAIR check valve will damage it.**
- **Replace the PAIR check valve as a unit if the stopper, reed, or seat is faulty.**

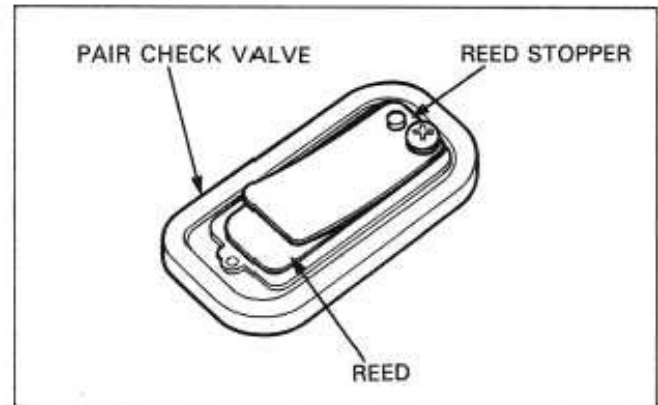

EMISSION CONTROL INFORMATION LABELS

Labels for the emission control system consist of three kinds of information labels as described below.

1. Emission control information label
 - Gives basic tune-up specifications.
2. Emission control information update label
 - After making a high altitude carburetor adjustment, attach this label at the specified location. Instructions for obtaining the update label are given in Service Letter No. 132.
3. Vacuum hose routing diagram label (California model only)
 - Route the vacuum hoses as shown on this label. On after '85 models, all hoses used in the secondary air supply and evaporative emission systems are numbered for identification, so compare the hose number with this label when connecting one of these hoses.

NOTE

- Refer to the Model Specific manual for the location of each label.

EXAMPLE:



MEMO

8. FUEL SYSTEM

SERVICE INFORMATION	8-1	FUEL AUTO VALVE	8-8
TROUBLESHOOTING	8-2	CARBURETOR DISASSEMBLY/ INSPECTION	8-9
SYSTEM DESCRIPTION	8-3	CARBURETOR ASSEMBLY	8-14
ACCELERATOR PUMP	8-7	PILOT (OR AIR) SCREW ADJUSTMENT	8-18
AIR CUT-OFF VALVE	8-7	ACCELERATOR PUMP ADJUSTMENT	8-24
REED VALVE	8-7	HIGH ALTITUDE ADJUSTMENT	8-24
FUEL LINE	8-8		

SERVICE INFORMATION

▲ WARNING

- Gasoline is extremely flammable and is explosive under certain conditions.

- Work in a well ventilated area. Smoking or allowing flames or sparks in the work area or where gasoline is stored can cause a fire or explosion.

CAUTION

- Bending or twisting the control cables will impair smooth operation and could cause the cables to stick or bind, resulting in loss of vehicle control.
- Be sure to remove the diaphragms before cleaning air and fuel passages with compressed air. The diaphragms might be damaged.

- Refer to Model Specific manual for carburetor and reed valve removal/installation.
- When disassembling fuel system parts, note the locations of the O-rings. Replace them with new ones on reassembly.
- Before disassembling the carburetor, place a suitable container under the carburetor drain bolt, loosen the bolt, and drain the carburetor.
- After removing the carburetor, wrap the intake port of the engine with a shop towel or cover it with piece of tape to prevent any foreign material from dropping into the engine.

NOTE

- If vehicle is to be stored for more than one month, drain the float bowls. Fuel left in the float bowls may cause clogged jets, resulting in hard starting or poor driveability.

FUEL FRESHNESS AND TROUBLESHOOTING

Engine performance is directly related to the quality and freshness of the gasoline consumed. Therefore, it is important to be sure the fuel within the motorcycle, scooter or ATV you are servicing is usable for your testing procedures. You may save valuable troubleshooting time by replacing fuel if its quality or age is in doubt.

Detonation (or pinging) on acceleration is an indication that the fuel is either not of good quality or is too low in octane rating for your application.

Fuel should be no more than six to eight weeks old.

TROUBLESHOOTING

Engine won't start

- No fuel to carburetor
 - Fuel strainer clogged
 - Fuel tube clogged
 - Float valve stuck
 - Float level misadjusted
 - Fuel tank breather tube (or hole) clogged
 - Fuel pump malfunction
 - Fuel auto valve malfunction
- Too much fuel getting to the engine
 - Air cleaner clogged
 - Flooded carburetor
- Intake air leak
- Fuel contaminated/deteriorated
- Slow circuit or starting enrichment valve circuit clogged

Lean mixture

- Fuel jets clogged
- Float valve faulty
- Float level too low
- Fuel line restricted
- Carburetor air vent hole (or tube) clogged
- Intake air leak
- Fuel pump malfunction
- Fuel auto valve malfunction
- Vacuum piston faulty (CV type only)
- Throttle valve faulty

Rich mixture

- Choke valve or starting enrichment valve in ON position
- Float valve faulty
- Float level too high
- Air jets clogged
- Air cleaner element contaminated
- Flooded carburetor

Hesitation during acceleration

- Accelerator pump malfunction

Engine stalls, hard to start, rough idling

- Fuel line restricted
- Ignition malfunction
- Fuel mixture too lean/rich
- Fuel contaminated/deteriorated
- Intake air leak
- Idle speed misadjusted
- Fuel pump malfunction
- Fuel auto valve malfunction
- Air screw or pilot screw misadjusted
- Slow circuit or starting enrichment valve circuit clogged
- Float level misadjusted
- Fuel tank breather tube (or hole) clogged
- Evaporative emission carburetor air vent control valve (EVAP CAV control valve) faulty
- Hoses of the emission control system faulty
- Evaporative emission purge control valve (EVAP purge control valve) faulty

Afterburn or misfiring during acceleration

- Air cut-off valve malfunction
- Lean mixture in slow circuit
- Secondary air supply system faulty
- Hose of emission control system faulty

Afterburn or misfiring during acceleration

- Ignition system faulty
- Fuel mixture too lean

Poor performance (driveability) and poor fuel economy

- Fuel system clogged
- Ignition malfunction
- Faulty evaporative emission carburetor air vent control valve (EVAP CAV control valve)
- Damaged/misconnected emission control system house

SYSTEM DESCRIPTION

CARBURETOR

As the piston begins its descent at the start of the induction phase (the period when the air-fuel mixture is drawn in), pressure in the cylinder drops, causing air to flow from the air cleaner, through the carburetor and into the cylinder. The function of the carburetor is to atomize the fuel and create an air-fuel mixture.

As in the figures on the right, air drawn into the carburetor passes through constriction A, where it gains speed. The constriction is known as the venturi section of the carburetor. This increase in flow speed is accompanied by a fall in pressure in the venturi, which is used to draw off fuel from the outlet. The fuel is atomized as it is drawn into the venturi under the influence of atmospheric pressure, and is mixed with the incoming air.

Carburetors are also equipped with mechanisms for regulation of the air and mixture volumes. A throttle valve is used to regulate the flow of air-fuel mixture, and a choke is included for adjusting the air flow under starting conditions.

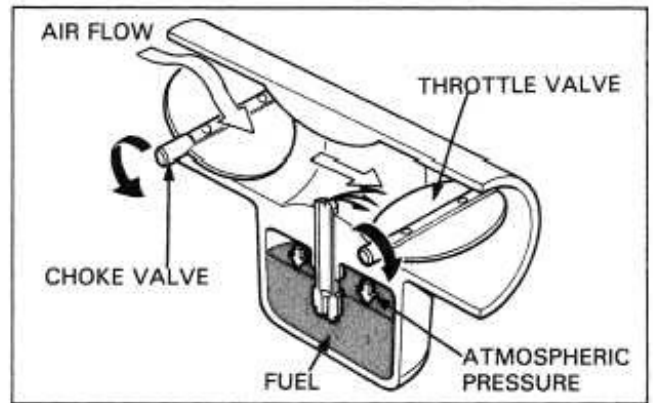
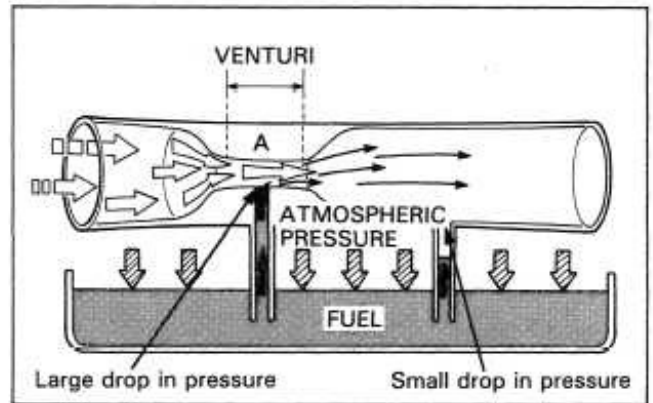

Types of carburetors

Carburetors which alter the diameter of the venturi by throttle valve movement are known as variable venturi types. The variable venturi continuously changes in diameter from low to high speed in proportion to the intake air volume to give smooth aspiration at low speeds and improved power output in the high speed range. Honda motorcycles, scooters and ATVs use one of two variable venturi designs.

1. The constant velocity type (CV): the venturi diameter is altered automatically by vacuum piston that rises and falls to alter the diameter. (The throttle valve is installed as a separate mechanism.)
2. The piston valve or flat slide type: a throttle-controlled piston is used to alter the venturi diameter.

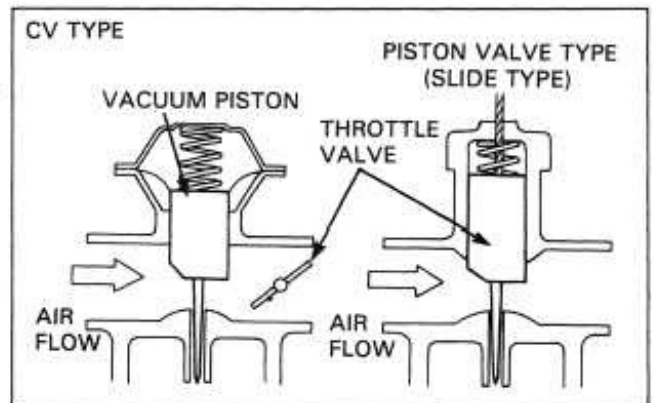

Principle of the vacuum piston operated CV type

As the engine is started and the throttle valve opens, the air flow in the main bore exerts a strong negative pressure on the lower section of the vacuum piston (see Carburetor theory). At this point, air is drawn out of the carburetor's vacuum chamber and pressure in the chamber drops. The diaphragm is lifted due to atmospheric pressure, and the vacuum piston is raised. When the throttle valve is closed, air flow in the main bore is obstructed. Pressure returns to that of the atmosphere and the vacuum piston is lowered by spring force.

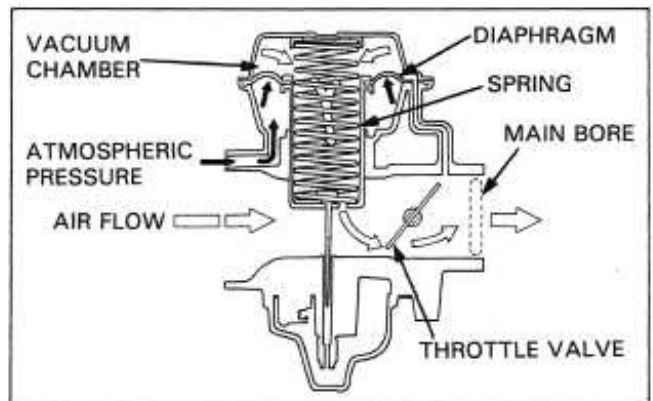

FUEL SYSTEM

Operation of systems

The carburetor is comprised of a starting system which uses either a choke valve or starting enrichment valve, a float system for fuel supply, and slow and main jet systems, etc.

The fuel supply system varies with the degree of throttle opening and regulates fuel according to a slow system at low throttle openings (throttle opening: fully closed to 1/4 open). At medium throttle openings (opening: 1/8–3/4), the main system's jet needle is used to regulate the fuel. The straight section of the jet needle regulates at 1/8–1/2, and the jet needle clip position or jet needle tapered section diameter regulates at 1/4–3/4. When the throttle is fully open (actually a range of 1/2–fully open) the fuel is regulated by the main jet of the main system.

Float system

The float chamber holds a constant level of fuel so the engine is provided with a stable supply of the required air-fuel mixture.

As fuel is consumed and the level in the chamber falls, the float and float valve are lowered and the chamber is immediately refilled to a specified level. A rise in fuel level causes the float and its valve to rise, the valve contacts the valve seat and the fuel supply is cut off. This operation repeats while the engine runs.

The float valve contains a spring which lightly depresses the valve so that it does not become dislodged from the seat by vibration when the vehicle is running.

To keep the inside of the float chamber at atmospheric pressure, there is a connection to the outside of the carburetor known as the air vent passage.

An overflow tube is provided to drain off any excess fuel to the outside of the carburetor, should the valve and seat become separated due to the intrusion of dirt or other foreign matter.

Starting system

To improve starting when the engine is cold and the fuel is not sufficiently gaseous, the carburetor is equipped with either a choke or starting enrichment valve to enrich the mixture.

<Choke system>

A valve is fitted to the air cleaner side of the carburetor. The valve is shut down during starting to reduce the mass flow of air and create an increase in negative pressure in the main bore. The resulting mixture is rich, having a proportionally low volume of air.

The choke valve is provided with a relief mechanism which ensures the optimum opening of the valve under conditions of negative pressure above a certain level, thus preventing the supply of an over-rich mixture to the engine.

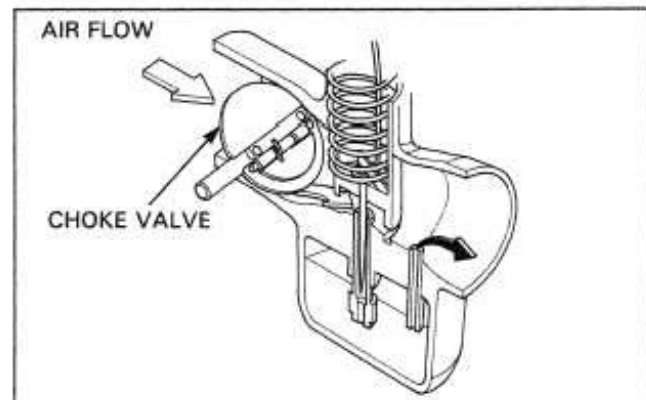
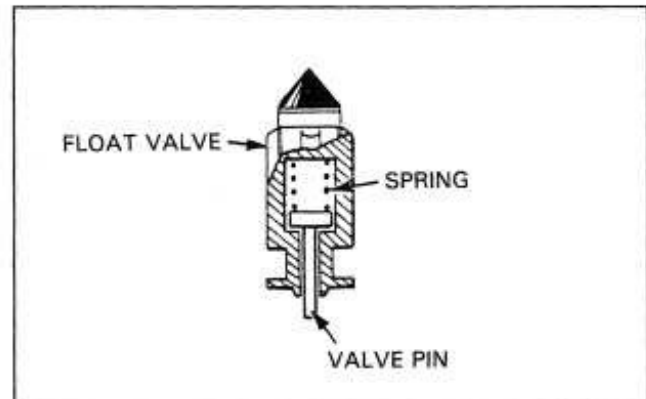
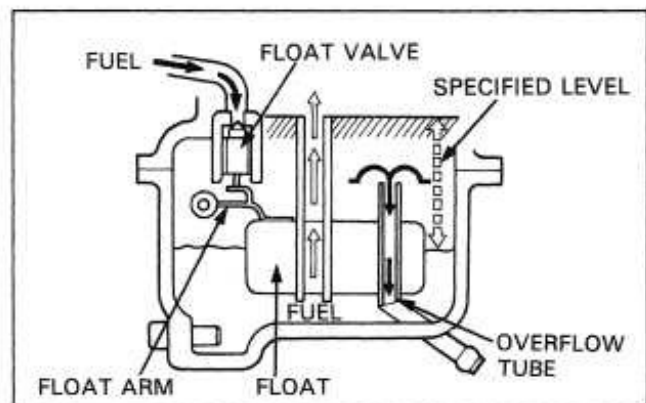
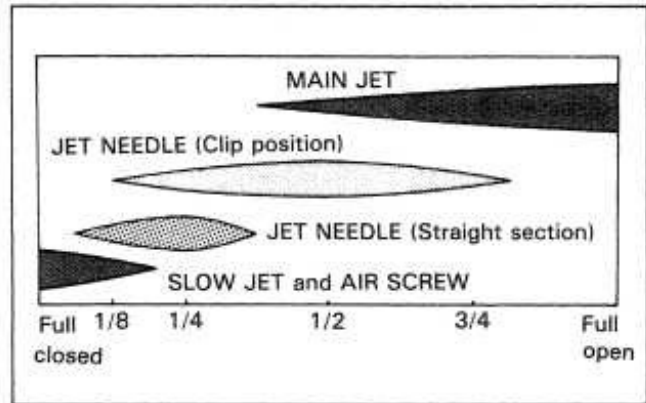

<Starting enrichment valve system (manual)>

As the starting enrichment valve is opened, the starting enrichment circuit connects with the main bore. As a vacuum is created in the main bore on starting, air and fuel (drawn from the starting enrichment air jet and starting enrichment fuel jet respectively) are injected into the main bore to supply a rich mixture.

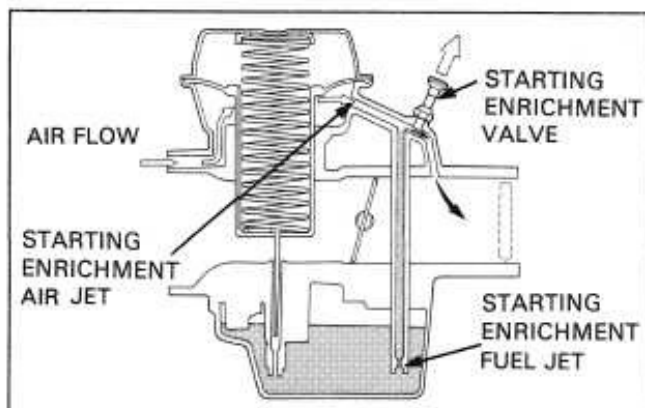

<Starting enrichment thermal valve system>

The starting enrichment thermal valve is a device for increasing the volume of fuel. It is comprised of components such as a PTC heating element, thermo-wax, a liquid medium, piston and the starting enrichment valve.

The principle of operation is as follows:

When the engine is stopped and there is no production of current from the alternator, the enrichment valve is maintained in the raised position by a spring. In this position the fuel increase circuit is fully open, ready for supply at any time.

When the engine starts, fuel is supplied through the fuel increase circuit.

At the same time, the alternator sends current to the PTC for heating. The increase in heat is sensed by the thermowax which begins to expand. The movement is transmitted through the liquid medium to the piston, set collar and set spring, and the enrichment valve is depressed. As the valve is lowered, the jet needle starts to shut off the fuel increase circuit, which, after a few minutes closes fully, ending fuel compensation.

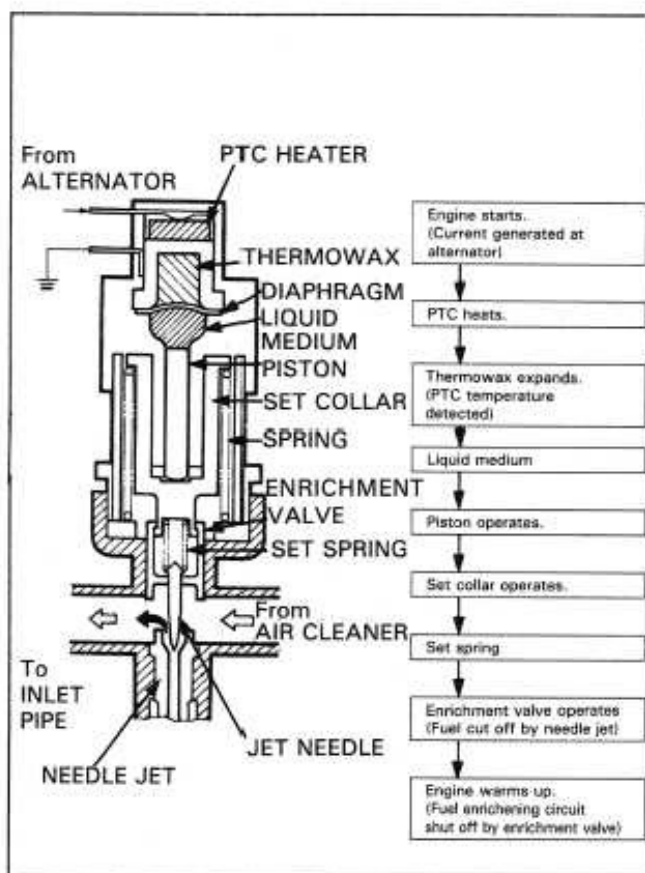

Slow system (low degree of opening)

As the throttle valve is only slightly open at low engine speeds (degree of opening: fully closed - 1/4), pressure on the intake side is low, which allows some residual gas from combustion to be sucked back into the intake manifold where it is mixed with a fresh charge from the carburetor. The resulting mixture is lean.

Low engine speed is linked with lower compression in the cylinder, resulting in a richer mixture, and it is necessary to raise the combustion velocity.

For this purpose, the engine includes a slow fuel supply system which is separate from the main system.

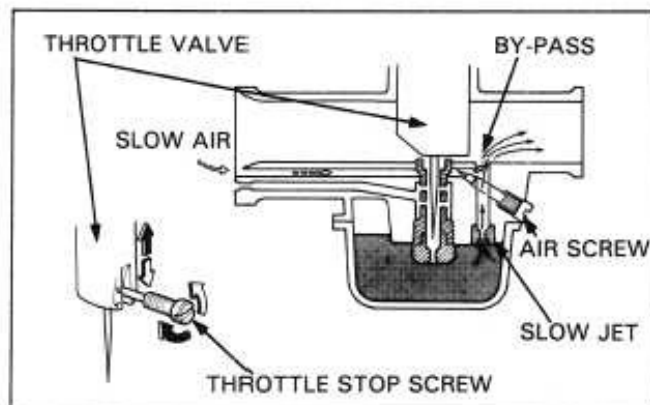

FUEL SYSTEM

Piston valve type throttle valves have a cut-out on the intake side. The larger the cut-out, the greater the volume of air entering and the leaner the mixture.

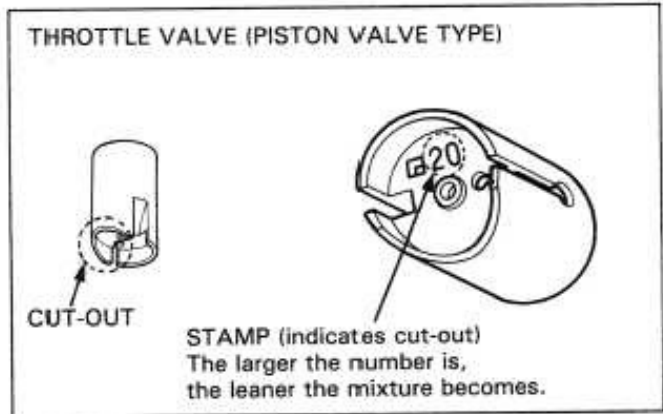

Main system (medium throttle opening)

When the throttle valve is opened to raise the engine speed, a greater volume of air-fuel mixture is required than for idling. The carburetor is equipped with the main system for this purpose. The degree of opening of the throttle valve is divided into two stages.

With a degree of opening $1/8 - 1/2$: the air flow in the main bore facilitates a drawing up of the fuel from the gap between the jet needle and needle jet (see Carburetor Theory). The fuel is aerated by air which has entered the air bleed hole of the needle jet holder from the main air jet.

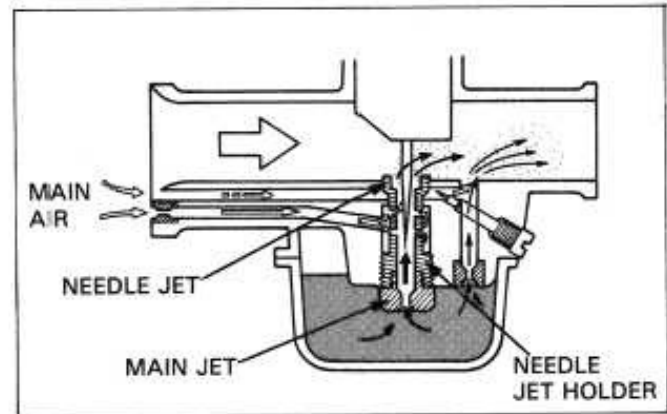

With a degree of opening $1/4 - 3/4$: the fuel drawn from the tapered section of the jet needle is regulated. The greater the valve opening, the further the tapered jet needle rises, increasing the cross sectional area for fuel passage and thus the volume of fuel supplied. In piston type throttle valves, the jet needle contains clip grooves in five stages (Stage 1, 2, 3, etc counted from the top). The clip position stage number increases with an increase in the degree of throttle opening, raising the cross sectional area of fuel passage, and hence the volume of fuel.

The size of the main jet does not affect the air-fuel mixture ratio at this stage, as the fuel flow at main jet is greater than at the needle jet.

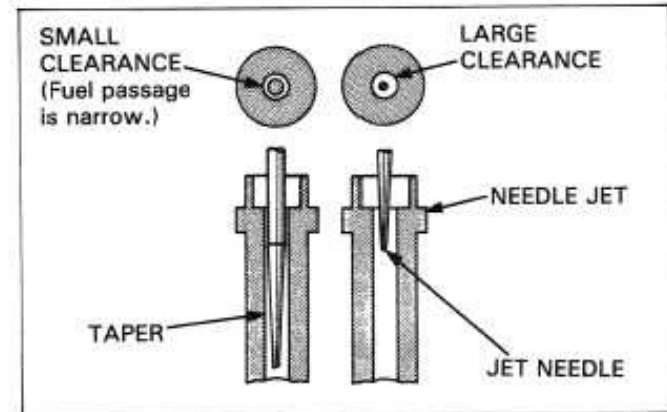

Main system (fully open)

With a degree of throttle opening of $1/2 -$ fully open, the venturi bore diameter and mass flow of air become maximum. At this time the volume of fuel drawn from the gap between the needle jet and jet needle becomes too great and exceeds the flow volume of the main jet.

When the clearance between the needle jet and jet needle is too great, the fuel flow is regulated by the main jet to prevent an overly rich fuel-air mixture.

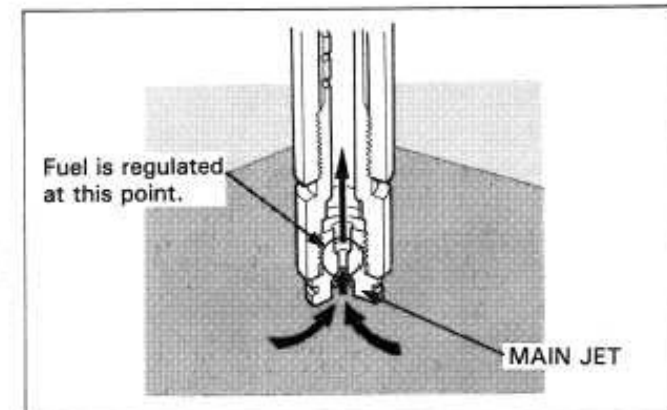

ACCELERATOR PUMP

When the throttle valve is opened suddenly, the air-fuel mixture drawn into the cylinder momentarily becomes lean. Because the vacuum at the venturi drops, air flow at the venturi slows down and the drawn-up fuel becomes too little compared with the air. To avoid thinning of the mixture under these conditions, an accelerator pump is used for temporary enrichment. The principle of operation of the pump is as follows:

As the throttle valve is opened, the pump's diaphragm is depressed by the pump rod. At this time the inlet check valve is shut, so the pump chamber undergoes a rise in pressure. The outlet check valve is then opened and fuel is supplied to the main bore via the pump hole.

As the throttle valve closes, the accelerator pump's diaphragm is opened and fuel from the float chamber enters the pump chamber. The outlet check valve is closed at this point to prevent air being drawn in through the pump hole.

- Throttle valve opens:

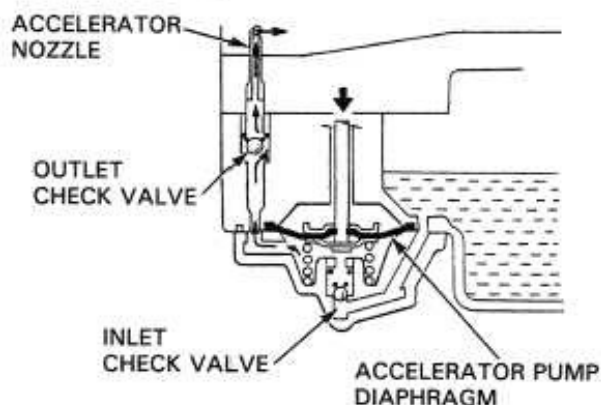

- Throttle valve closes:

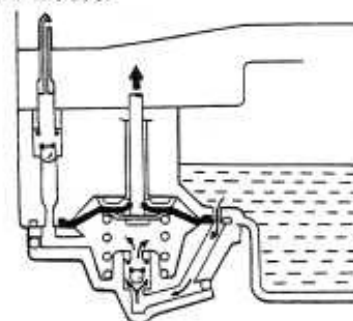

AIR CUT-OFF VALVE

When the throttle lever is turned in the "close" direction and engine braking is applied, the fuel mixture becomes lean. An ignited air/fuel mixture is discharged into the exhaust pipe, resulting in afterburn. To prevent this afterburn, the air cut-off valve shuts the air passage to the slow jet to temporarily make the fuel mixture rich.

With the throttle valve closed and the vacuum in the main bore increased, vacuum in the air cut-off valve also increases and moves the diaphragm to shut the air passage.

With the vacuum in the main bore decreased, the spring moves the diaphragm backward and opens the air passage.

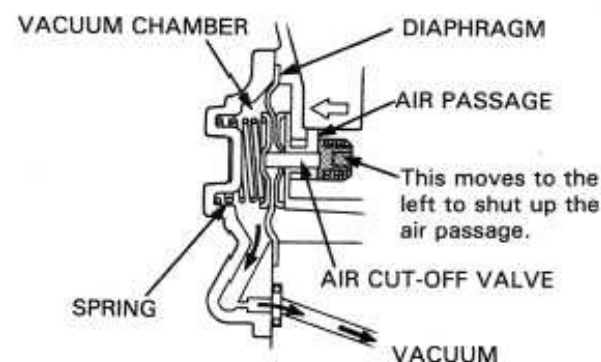

REED VALVE (2-STROKE ENGINES)

INSPECTION

Refer to the Model Specific manual for removal/installation.

Check the reed valve for fatigue or damage and replace the reed valve assembly if necessary.

Check the reed valve seat for cracks, damage and clearance from the reed and replace the reed valve assembly if necessary.

NOTE

- Be sure to replace the reed valve as an assembly. Disassembling or bending the reed stopper will cause engine trouble.

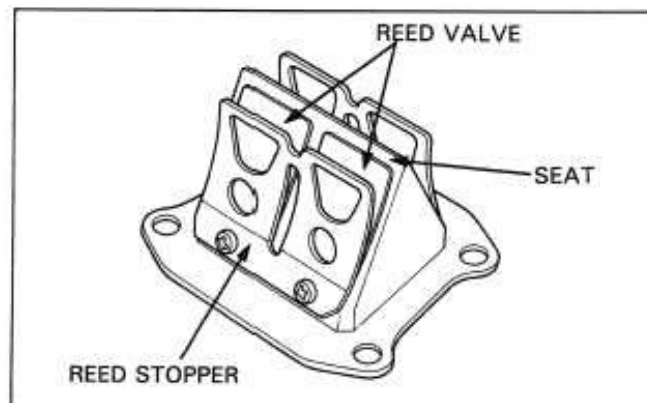

FUEL SYSTEM

FUEL LINE

NOTE

- Refer to section 2 for fuel filter inspection.

1. Check the fuel fill cap and/or fuel tank breather tube for clogging (no breather tube on California, on-road models).
2. Visually inspect the fuel strainer for contamination. Check the fuel flow with the fuel strainer installed and with the strainer removed. Replace the fuel strainer if it is excessively contaminated or if the fuel flow is not smooth.

NOTE

- Note the installation direction of the fuel strainer. Be sure to install it as shown in the drawing, i.e., with the cup facing down. Fuel flows even though the strainer is installed upside down, but it contaminates the inner wall of the strainer and prevents visual inspection of the strainer.

3. Remove the fuel valve lock nut and check the fuel strainer screen for contamination. Tighten the lock nut to the specified torque.

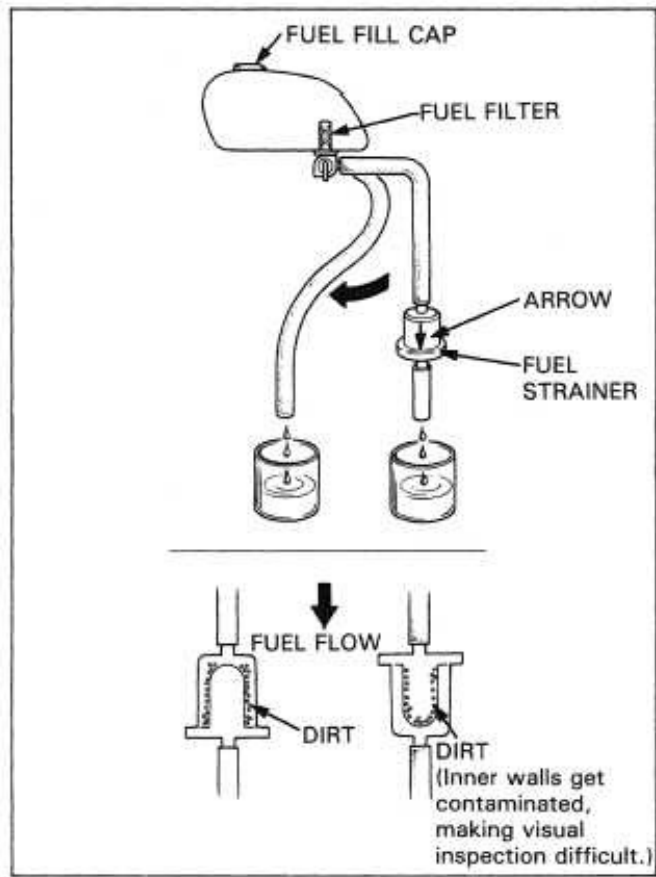

FUEL AUTO VALVE

The fuel auto valve has two diaphragms which are interconnected with an aluminum link.

When the engine is started, vacuum force is applied to the smaller diaphragm through the larger diaphragm and link, the fuel line opens and the fuel starts to flow.

When the engine is stopped, the diaphragms are returned to their original positions by the spring and the fuel line is blocked by the small diaphragm.

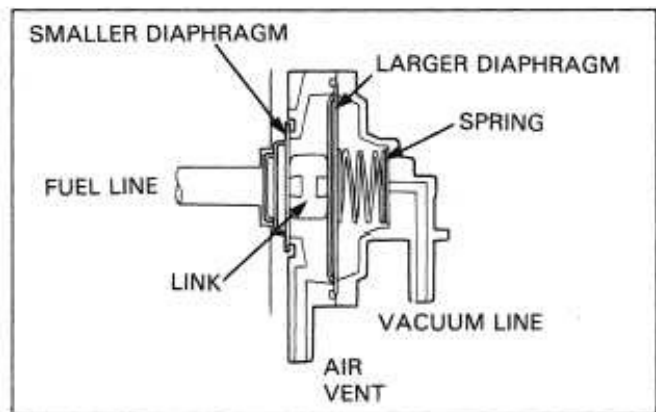

INSPECTION

⚠ WARNING

- Gasoline is extremely flammable and is explosive under certain conditions.

Keep flames and sparks away from gasoline and wipe up spilled gasoline at once.

CAUTION

- Be sure to remove the diaphragms from the fuel auto valve before using compressed air to blow out the air passages. Compressed air will damage the diaphragms or may force them off the aluminum link.

1. Disconnect the fuel line and place it in a clean container as shown.

NOTE

- Place a clean container under the fuel tube.
- Refer to the Model Specific manual for replacement.

2. Connect the fuel auto valve vacuum tube to the vacuum pump and apply vacuum. Be sure that the fuel flows out smoothly.
If the vacuum does not remain steady, it indicates the diaphragm is incorrectly installed or damaged.
If the vacuum remains steady, but the fuel flow is not smooth, it indicates a clogged filter or incorrectly installed diaphragm.
3. If the fuel flows without the vacuum applied, the diaphragm is incorrectly installed.

Refer to the Model Specific manual for replacement procedure.

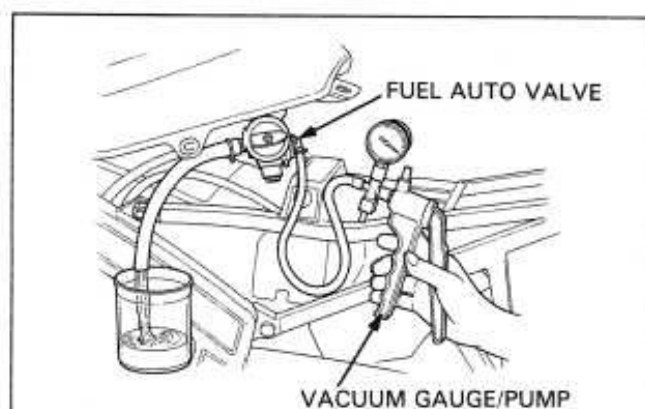

CARBURETOR DISASSEMBLY/INSPECTION

NOTE

- Refer to the Model Specific manual for carburetor removal and disassembly/separation.

THROTTLE VALVE/STARTING ENRICHMENT VALVE INSPECTION

Move each valve and be sure that it operates smoothly.

Check the throttle valve shaft for play.

Push the relief valve, if it is installed on the throttle valve, and be sure that it opens and closes smoothly.

THROTTLE VALVE INSPECTION (CV type)

Rotate the throttle drum and be sure that it operates smoothly.

Check the throttle valve shaft for play.

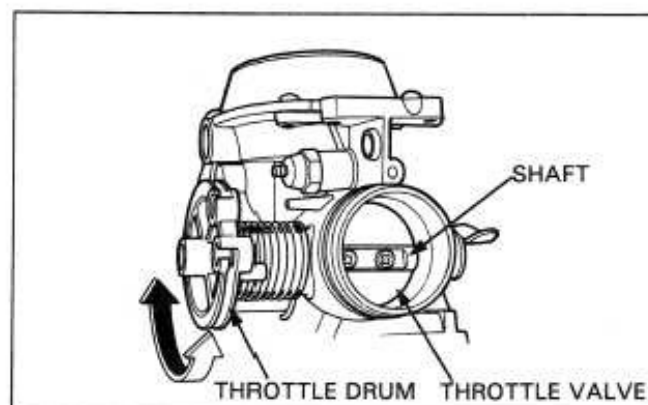
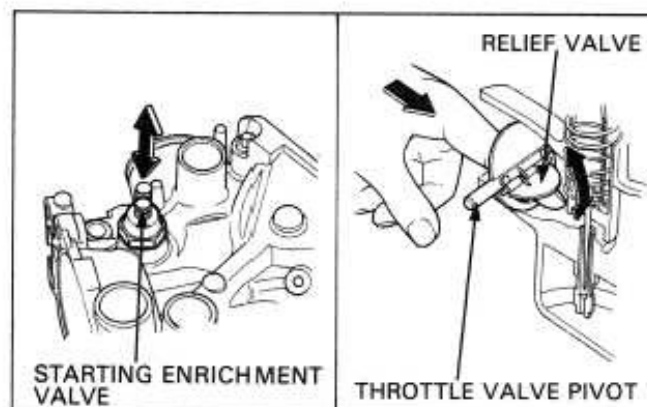

FUEL SYSTEM

STARTING ENRICHMENT THERMAL VALVE

Connect an ohmmeter to the starting enrichment thermal valve wire connector terminals and measure the resistance. If the resistance is greatly out of specification, it indicates a faulty PTC in the starting enrichment thermal valve. Replace the starting enrichment thermal valve.

NOTE

- The starting enrichment thermal valve might be normal if the resistance is only slightly out of specification. However, be sure to check all related parts for trouble.
- Refer to the Model Specific manual for specified resistance.

Remove the carburetor and let it cool down for 30 minutes. Insert a vinyl tube into the fuel enriching circuit and blow into the tube.

Air should flow into the circuit.

If air does not flow into the circuit, replace the starting enrichment thermal valve.

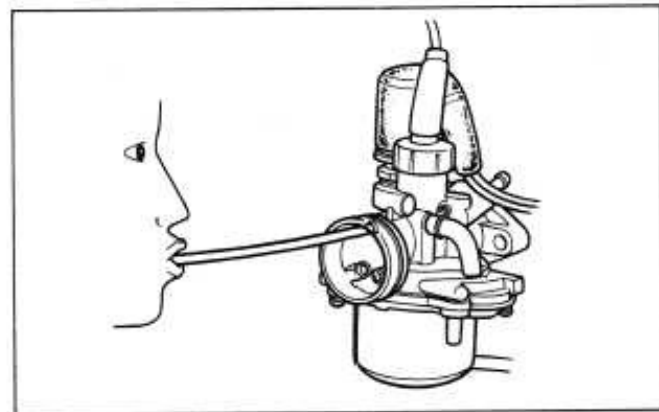
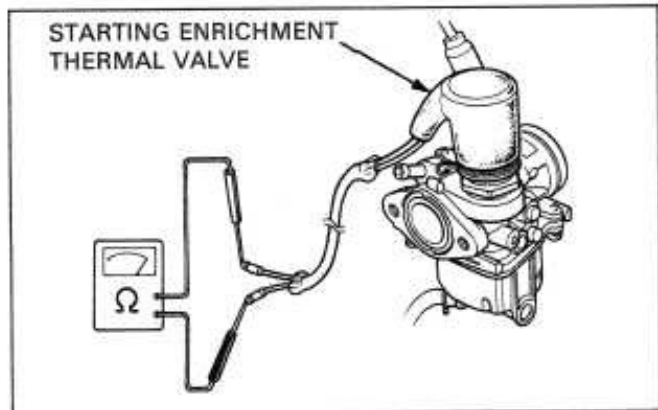

Connect the battery to the starting enrichment thermal valve terminals and wait for 5 minutes.

Insert a vinyl tube into the fuel enriching circuit and blow into the tube.

Air should not flow into the circuit.

If air flows into the circuit, replace the starting enrichment thermal valve.

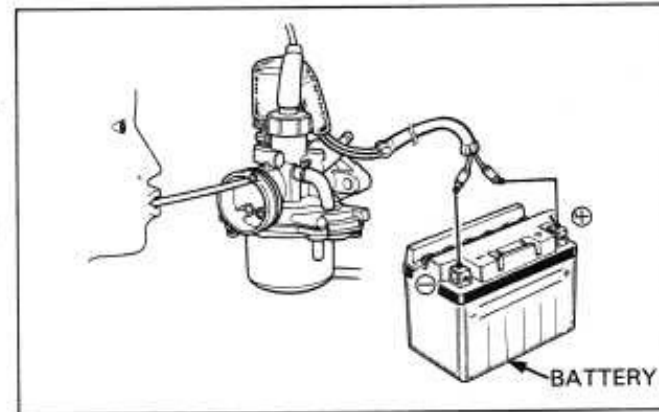

Check the resistor if the starting enrichment thermal valve is normal but engine is still hard to start.

If there is a broken wire in the resistor, current will not flow to the PTC and the starting enrichment thermal valve will not operate.

If there is a shorted wire in the resistor, current of a higher voltage than specified will reach the PTC. This will cause the fuel enriching circuit to close too soon, and starting will be difficult.

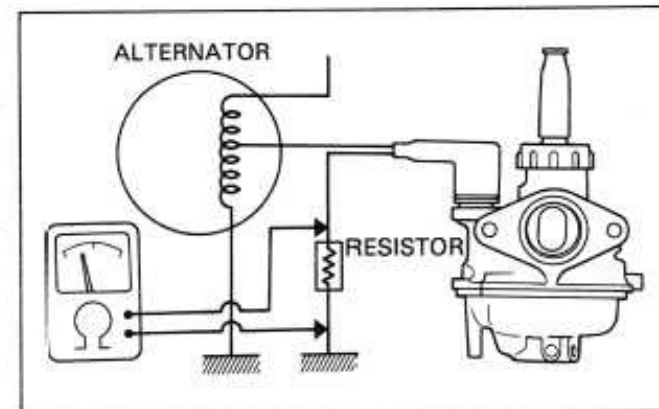

STARTING ENRICHMENT THERMAL VALVE REMOVAL

Remove the starting enrichment thermal valve cover.

Remove the screws and set plate.

Remove the starting enrichment thermal valve from the carburetor body.

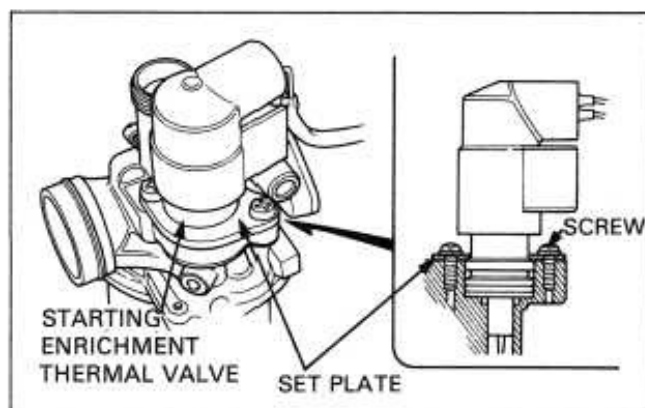

STARTING ENRICHMENT VALVE (Manual)

Loosen the starting enrichment valve nut and remove the valve spring and valve.

Check the valve face for scores, scratches or wear and replace if necessary.

Check the seat at the tip of the valve for stepped wear and replace if necessary.

If the valve seat is worn or damaged, it will not close the fuel line of the starting enrichment circuit, resulting in a constantly rich fuel mixture.

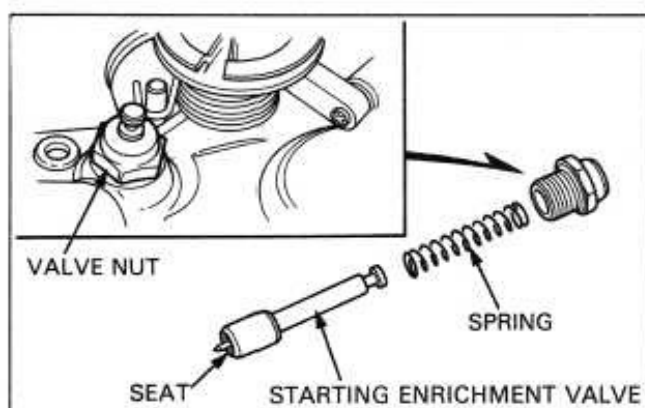

THROTTLE VALVE (Piston valve type)

CAUTION

- Some carburetor/cables have a one-piece throttle cable/carburetor top assembly. Do not try to remove the throttle cable from the carburetor top.

Remove the carburetor top and pull the throttle valve out of the carburetor.

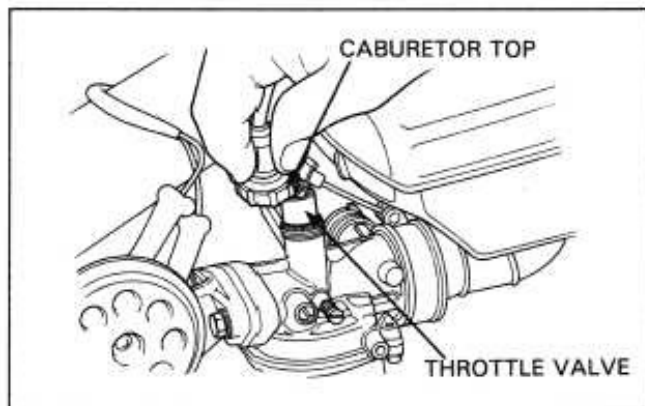

While compressing the spring, disconnect the throttle cable from the throttle valve.

NOTE

- If the throttle valve is linked to the cable, refer to the Model Specific manual for each model for removal/disassembly steps.

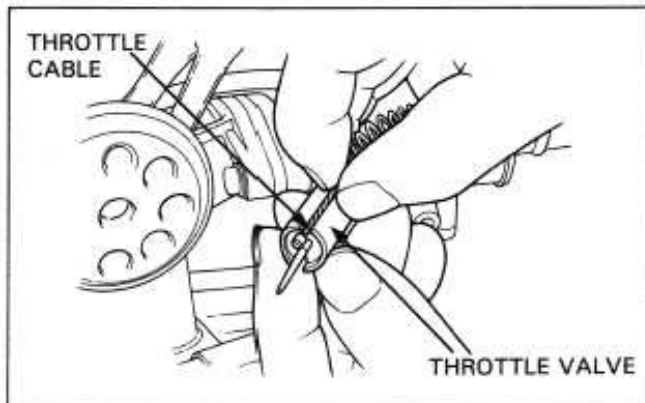

FUEL SYSTEM

Remove the jet needle retainer and jet needle from the throttle valve.

Check the jet needle for stepped wear. The fuel supply to the main circuit cannot be adjusted if the jet needle is worn.

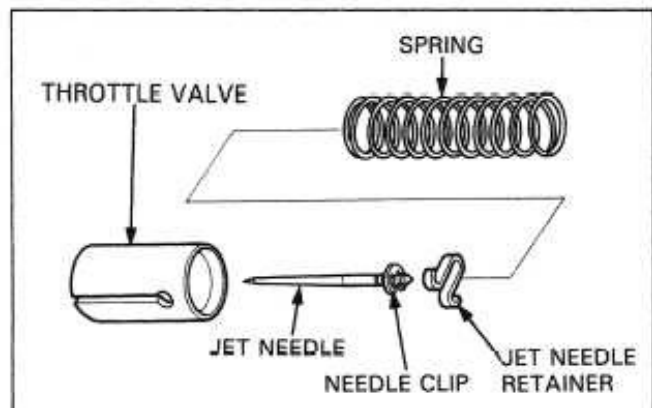

VACUUM PISTON (CV type)

Remove the screws, vacuum chamber cover, spring, and vacuum piston assembly from the carburetor.

Check the piston for smooth operation in the carburetor body.

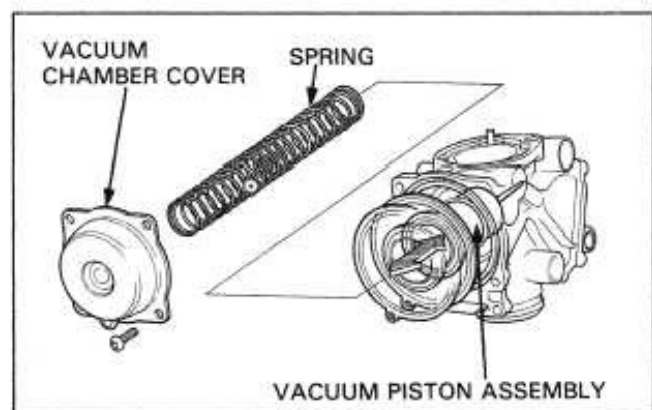

Turn the jet needle holder counterclockwise while pressing it in and remove it.

Remove the spring, spring holder, jet needle, needle holder and washer from the vacuum piston.

NOTE

- Certain models are not equipped with a spring holder.

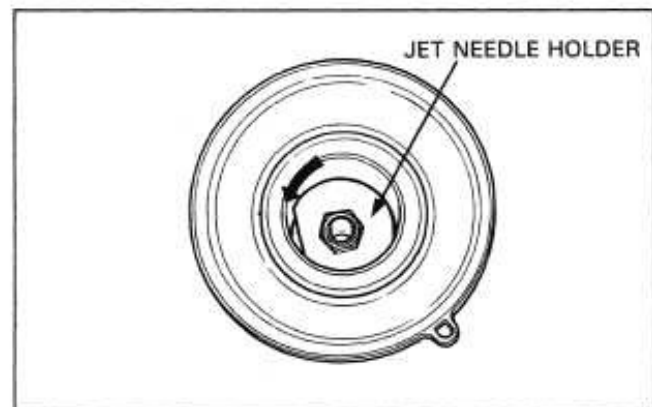

Check the jet needle for stepped wear and replace if necessary.

Check the vacuum piston for damage and replace if necessary.

Check the diaphragm for damage, pin holes, wrinkles and bends and replace if necessary.

Air leaks out of the vacuum chamber if the diaphragm is damaged in any way—even a pin hole.

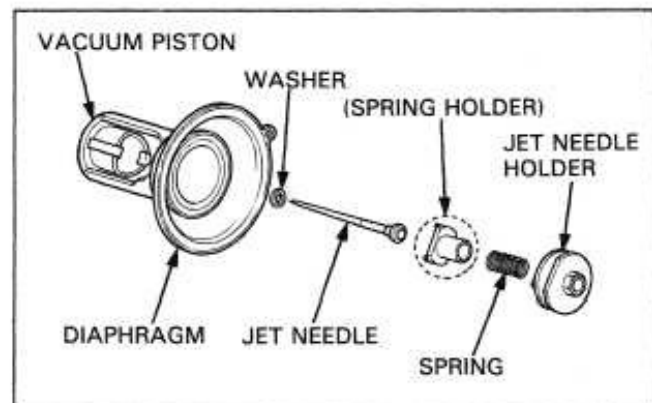

FLOAT/JETS

Remove the float chamber.

Remove the float pin, float and float valve.

Check the float for damage. If it is a hollow float type, also check it for deformation and fuel in the float.

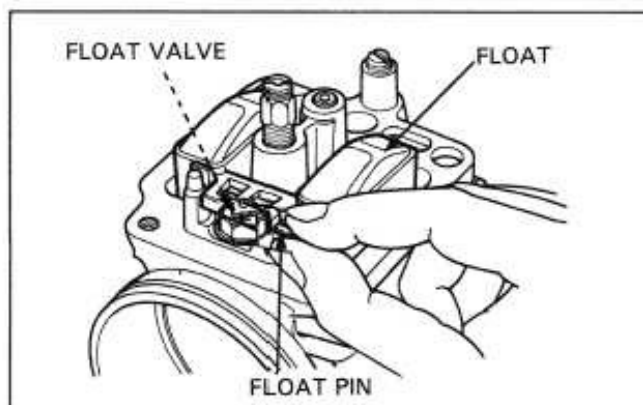

Check the float valve and valve seat for scores, scratches, clogging and damage. Replace if necessary.

Check the tip of the float valve, where it contacts the valve seat, for stepped wear or contamination. Replace the float valve if its tip is worn or contaminated. A worn or contaminated valve does not seat properly and will eventually flood the carburetor.

Remove the valve seat, if it can be removed. (Refer to the Model Specific manual.)

Replace the sealing washer.

Check the filter for damage or clogging. Blow the filter with low pressure air and clean it.

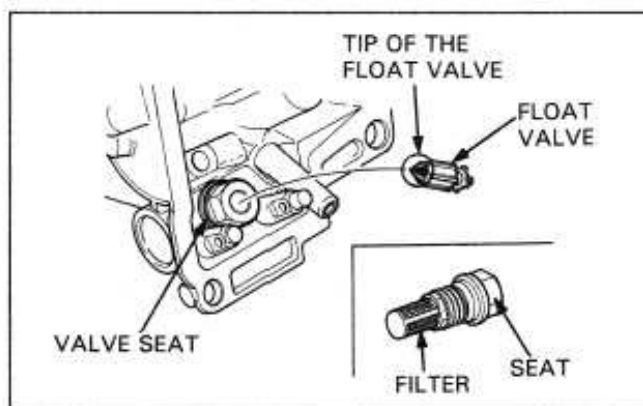

Remove the main jet, needle jet holder, needle jet and slow jet.

NOTE

- Not all carburetors have a removable needle jet and slow jet. (Refer to the Model Specific manual.)

Turn in the pilot (or air) screw and record the number of turns it takes before it seats lightly.

NOTE

- Do not force the screw against its seat; the seat will be damaged.
- Motorcycles with emission control system: Refer to page 8-18 for pilot (or air) screw removal.

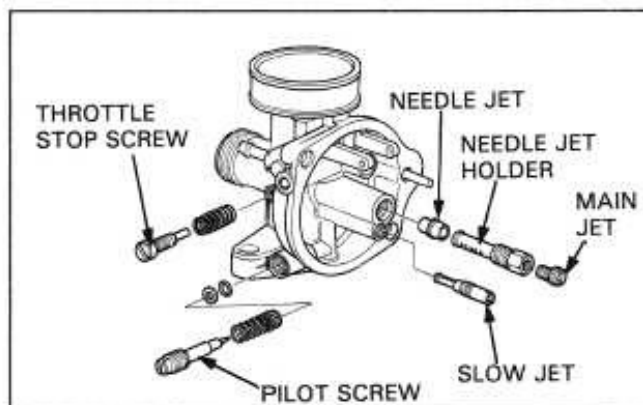

Clean the jets with cleaning solvent and, if necessary, blow open with compressed air.

If the motorcycle is equipped with an accelerator pump, blow open the fuel passages in the float chamber with low pressure air.

FUEL SYSTEM

ACCELERATOR PUMP

Remove the screws and diaphragm cover.

Remove the spring and diaphragm.

Check the rod for bends or damage.

Check the diaphragm for damage or pin holes.

Damage to the rod and/or diaphragm reduces the efficiency of the pump, leading to "hunting" during acceleration.

Blow open the fuel passages in the diaphragm cover with low pressure air.

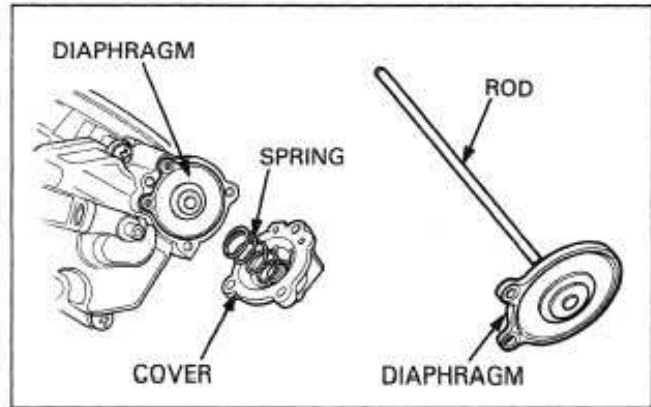

AIR CUT-OFF VALVE

Remove the screws, air cut-off valve cover, spring, diaphragm and O-ring.

Check the diaphragm for damage or pin holes.

Check the O-ring for damage or fatigue.

A worn O-ring and/or damaged diaphragm causes air to leak from the air cut-off valve vacuum chamber.

Blow open air passages in the cover with compressed air.

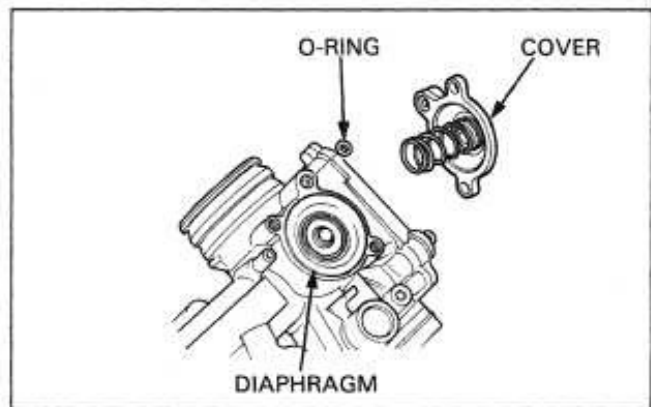

CARBURETOR CLEANING

After removing all parts, blow open air and fuel passages in the carburetor body with compressed air.

CAUTION

- Cleaning the air and fuel passages with a piece of wire, will damage the carburetor body or fuel pump.
- Remove the diaphragms to prevent damage to them before using air to blow open the passages.

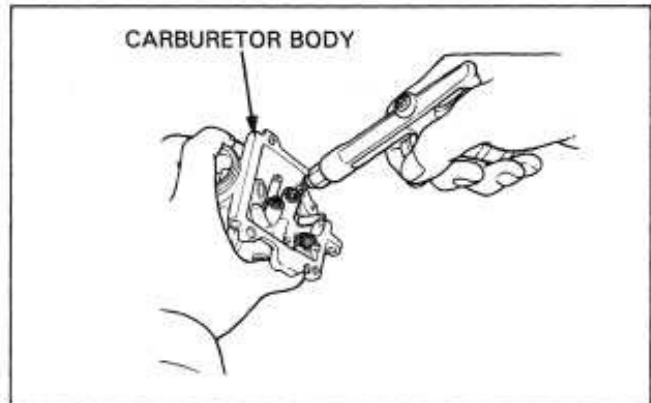

CARBURETOR ASSEMBLY

AIR CUT-OFF VALVE

Install the diaphragm on the carburetor body.

Install the O-ring with its flat side pointed downward.

Install the spring on the cover and install the cover on the carburetor body. Be sure that the diaphragm and O-ring do not interfere with the cover.

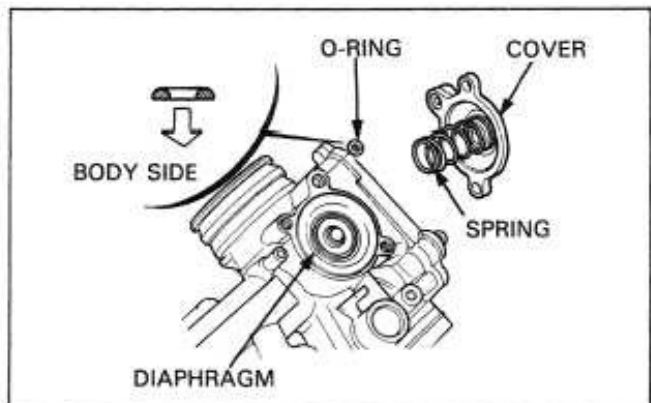

ACCELERATOR PUMP

Align the projections on the diaphragm with the grooves in the float chamber.

Install the spring on the diaphragm cover and install the cover on the float chamber being careful not to pinch the diaphragm.

Adjust the accelerator pump (page 8-24).

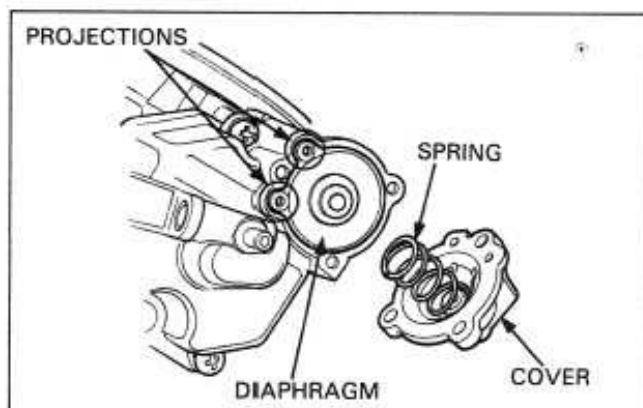

FLOAT/JETS ASSEMBLY

Install the needle jet, needle jet holder, main jet, slow jet, throttle stop screw and pilot (or air) screw on the carburetor body.

Tighten the pilot (or air) screw until it seats lightly, then turn it out as much as the number recorded during removal.

CAUTION

- Tightening the pilot (or air) screw against its seat will damage the seat.

NOTE

- Be sure to install the needle jet with the smaller hole toward the float chamber.
- Install the pilot (or air) screw and its O-ring and washer in the order as shown in the drawing. If the pilot (or air) screw and carburetor body are replaced with the new ones, adjustment is necessary.
- Motorcycles with emission control systems: Refer to page 8-20 for the pilot (or air) screw installation (U.S.A. only).

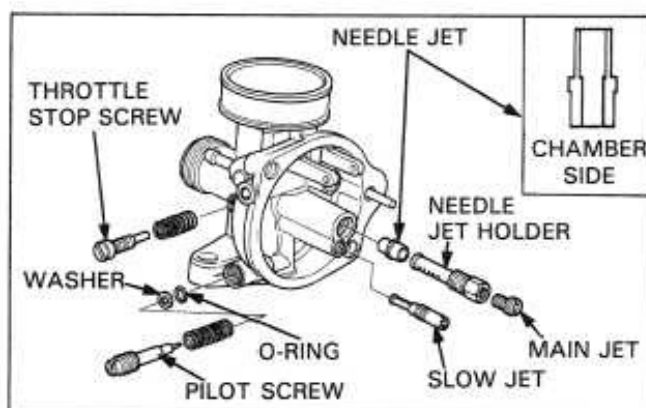

Install the float, float valve and float pin.

Install the O-ring on the float chamber and tighten the float chamber with the screws.

NOTE

- If the float valve must be hung from the float arm lip, note the installation direction of the float valve.

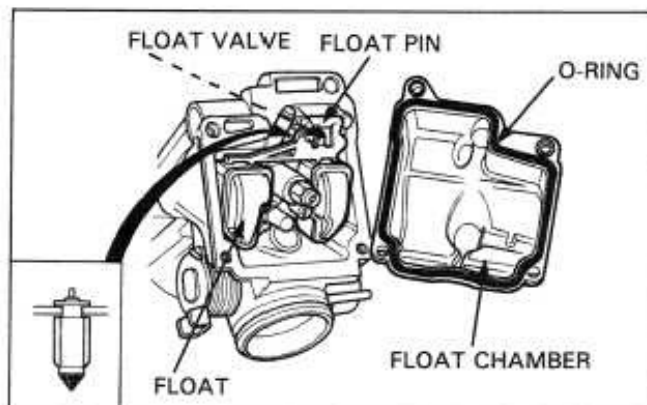

FUEL SYSTEM

FLOAT LEVEL INSPECTION

NOTE

- Check the float level after checking the float valve and float (page 8-13).
- Set the float level gauge so that it is perpendicular to the float chamber face and in line with the main jet.

Set the carburetor so that the tip of the float valve just contacts the float arm lip. Be sure that the float valve is securely in contact with the valve seat.

Measure the float level with the float level gauge.

TOOL

FLOAT LEVEL GAUGE 07401-0010000

If the level is out of specification and the float arm lip can be bent, adjust the float level by bending the lip. Non-adjustable floats must be replaced.

NOTE

- Be sure to keep the float level at the specified height. If the float level is low/high, fuel mixture becomes lean/rich.

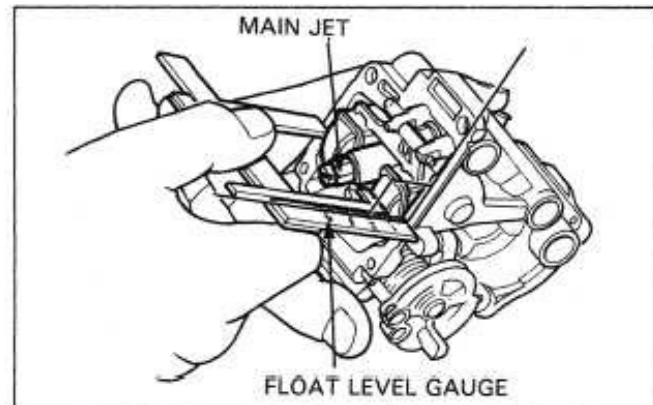

VACUUM PISTON (CV type)

Install the washer on the jet needle and install the jet needle in the vacuum piston.

(Install the spring holder with its pawls aligned with the grooves in the piston, if installed.)

Install the spring.

Turn the jet needle holder clockwise while pressing it into the vacuum piston until it locks. Projections on the vacuum piston and jet needle holder should be aligned after turning.

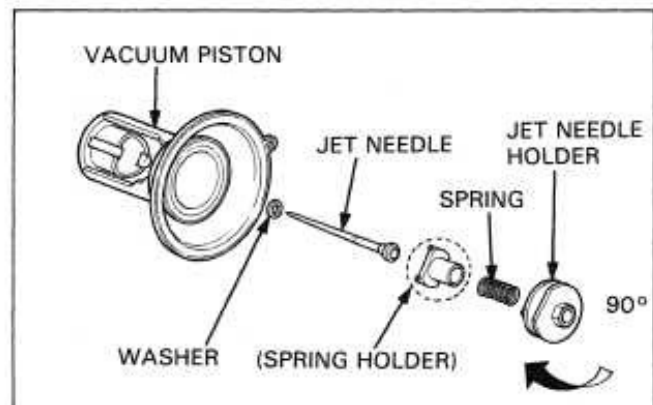

Install the vacuum piston on the carburetor body.

Lift the bottom of the piston with your finger to set the diaphragm rib in the groove in the carburetor body. Install the spring.

Install the vacuum chamber cover with its cutout aligned with the hole in the tab of diaphragm.

NOTE

- Be careful not to pinch the diaphragm, and to keep the spring straight.

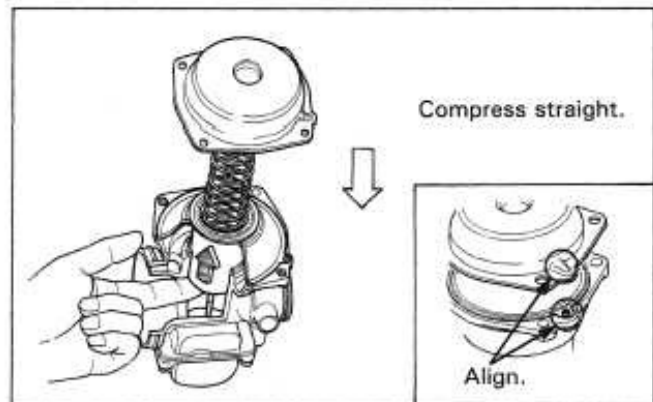

THROTTLE VALVE (Piston valve type)

NOTE

- Cable-operated throttle valve type carburetor (throttle valve is connected to the cable via the link): Refer to the Model Specific manual for throttle valve removal/disassembly.

Install the clip on the jet needle. (Refer to the Model Specific manual for the standard clip position.)

Install the jet needle into the throttle valve and secure with the retainer.

Route the throttle cable through the spring and compress the spring fully.

Attach the throttle cable end to the bottom of the throttle valve and thread the throttle cable through the slot in the valve.

Align the cutout in the throttle valve with the throttle stop screw on the carburetor body and install the valve on the carburetor.

NOTE

- Be sure that the throttle valve cutaway is toward the air cleaner housing side as it determines the volume of air for fuel mixture.

STARTING ENRICHMENT VALVE (MANUAL)

Install the starting enrichment valve, spring and nut.

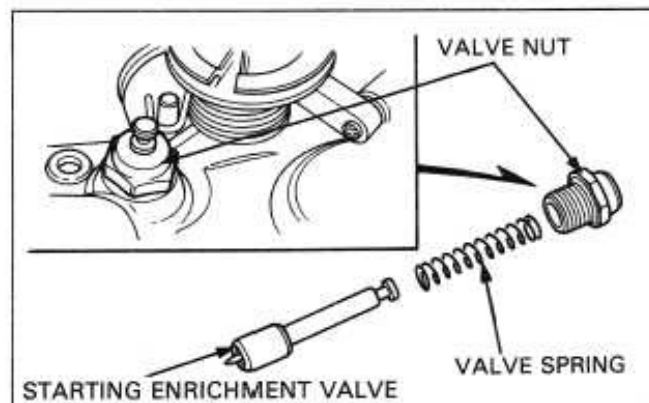
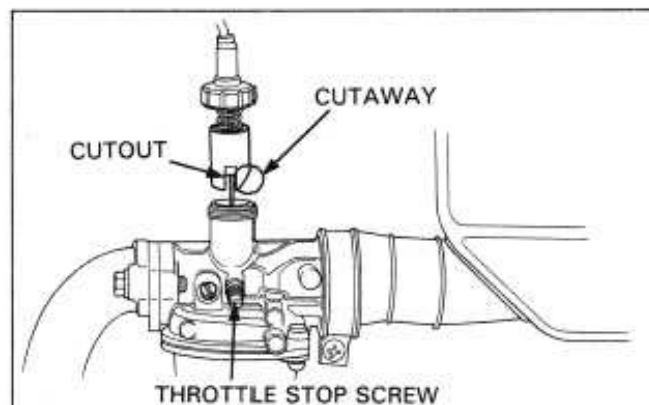
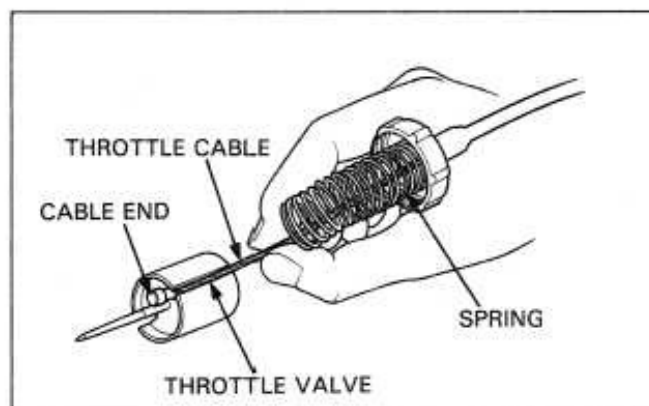
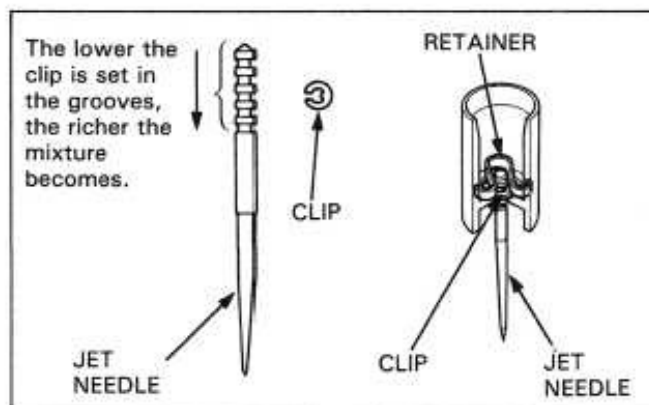

FUEL SYSTEM

STARTING ENRICHMENT THERMAL VALVE

Apply a small amount of grease to the O-ring and install the starting enrichment thermal valve into the carburetor body. Refer to the Model Specific manual for the starting enrichment thermal valve installation angle.

Secure the starting enrichment thermal valve with the set plate and screws.
Install the starting enrichment thermal valve cover.

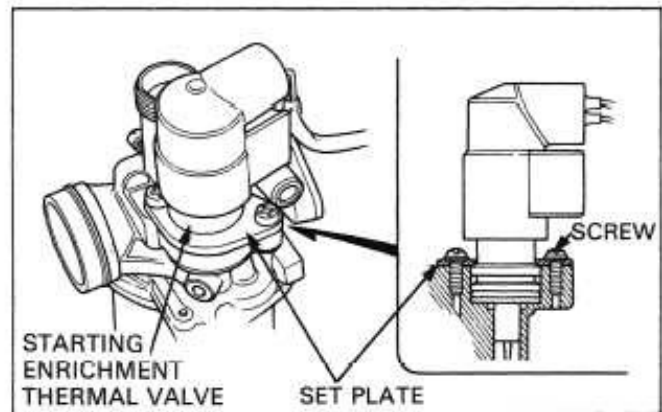

CARBURETOR SEPARATION/ASSEMBLY/INSTALLATION

Refer to the Model Specific manual for carburetor separation/assembly.

Check and adjust the carburetors as described below after the assembly.

Move the choke arm by hand and be sure that the starting enrichment valve operates smoothly.

Rotate the throttle drum and be sure that all the throttle valves open and close smoothly.

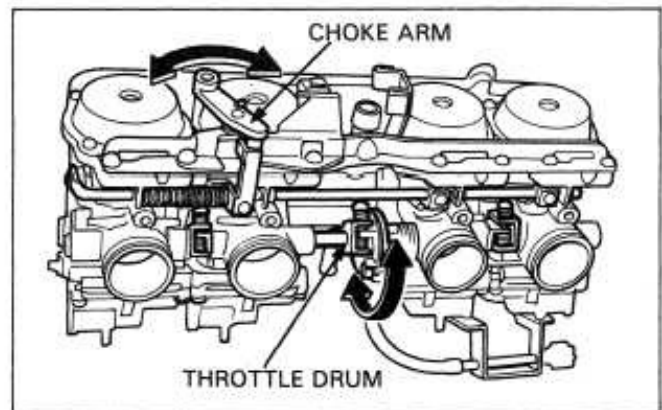

Turn the throttle stop screw to align the throttle valve with the edge of the by-pass hole in the base carburetor. (The base carburetor is the one on which the throttle stop screw is installed. Refer to the Model Specific manual.)

Align each throttle valve with the by-pass hole edge by turning the synchronization adjusting screws. (Refer to the Model Specific manual for the location of each synchronization screw.)

Install the carburetor and adjust the synchronization.

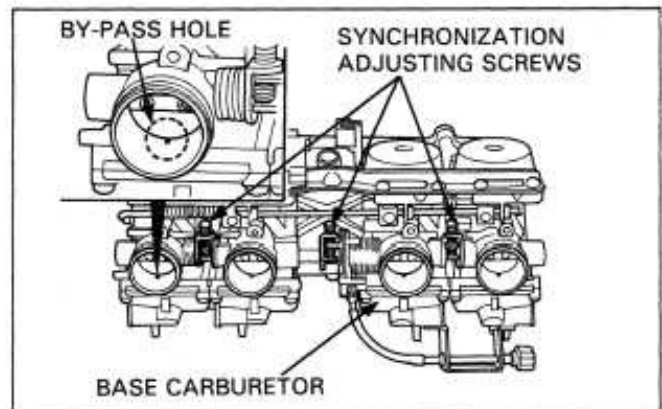

PILOT (OR AIR) SCREW ADJUSTMENT

PILOT (OR AIR) SCREW REMOVAL

NOTE

- Adjust the pilot (or air) screw after all other engine adjustments are within specifications.
- The pilot screw (or air screw) is factory pre-set and should not be removed unless the carburetor is overhauled.
- The screw limiter cap (or plug) is factory installed to prevent misadjustment. Do not remove the limiter cap (or plug) unless the screw is being removed.
- **PLUG TYPE ONLY:** Cover all openings with tape to keep metal particles out when the plug is drilled.

Limiters cap type

Using a pair of pliers, break off the pilot screw (or air screw) limiter cap and discard it.

Turn the pilot screw (or air screw) in and carefully count the number of turns before it seats lightly.

Make a note of this to use as a reference when reinstalling the pilot screw.

CAUTION

- **Tightening the pilot (or air) screw against its seat will damage the seat.**

Remove the pilot (or air) screw and inspect it. Replace it if it is worn or damaged.

Plug type

Center punch the pilot screw (or air screw) plug to center the drill point.

Drill through the plug with a 4 mm (5/32 in) drill bit. Attach a drill stop to the bit 3 mm (1/8 in) from the end to prevent drilling into the pilot screw.

CAUTION

- **Use extreme care when drilling into the pilot (or air) screw to avoid damaging it.**

Force a self-tapping 4 mm screw (H/C 069399, P/N 93903-3541) into the drilled plug and continue turning the screwdriver until the plug rotates with the screw.

Pull on the screw head with pliers to remove the plug.

Use compressed air to clean the screw area and remove metal shavings.

Turn the screw in and carefully count the number of turns until it seats lightly. Make a note of this to use as a reference when reinstalling the screw.

CAUTION

- **Tightening the pilot (or air) screw against its seat will damage the seat.**

Remove the screw and inspect it. Replace it if it is worn or damaged.

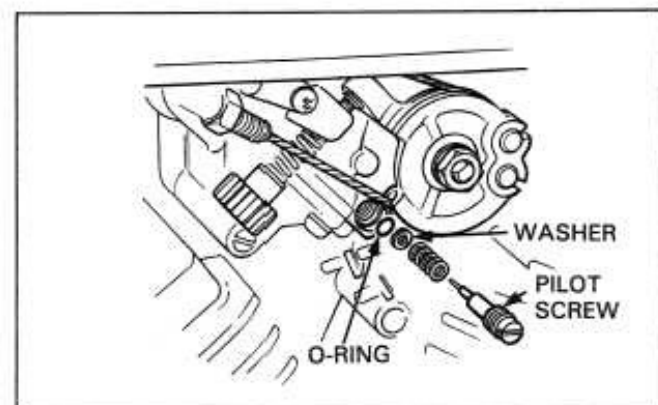
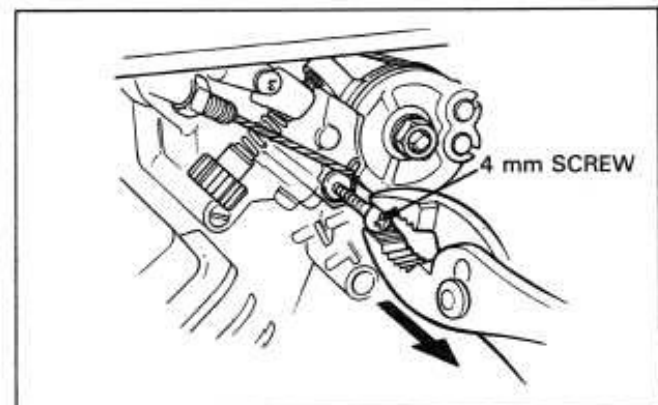
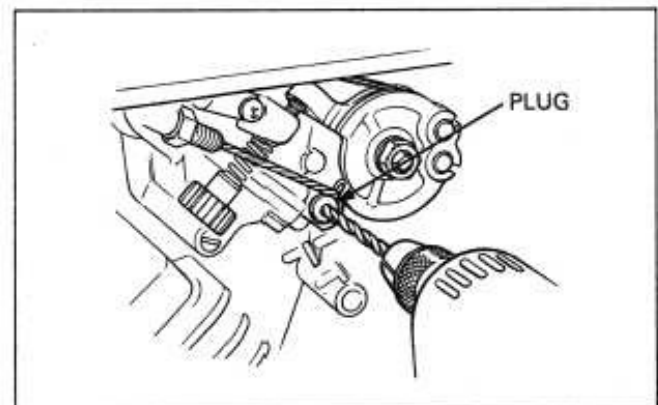
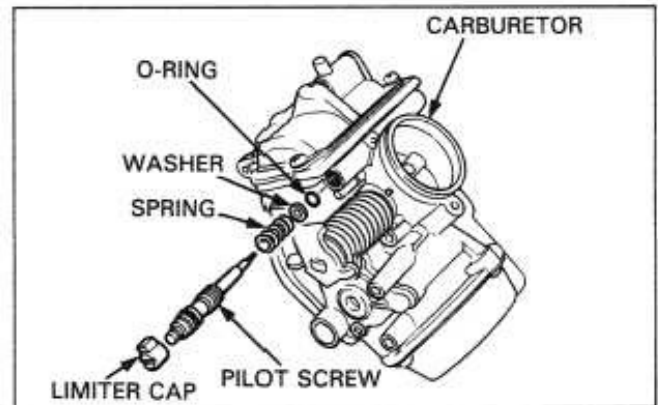

FUEL SYSTEM

PILOT (OR AIR) SCREW INSTALLATION

Install the screw and return it to its original position as noted during removal.

Perform the pilot screw (or air screw) adjustment if a new screw is installed.

NOTE

- If you replace the pilot screw in one carburetor, you must replace the pilot screws in the other carburetors for proper pilot screw adjustment.
- Do not install a limiter cap or plug over a pilot (or air) screw until the screw has been properly adjusted.

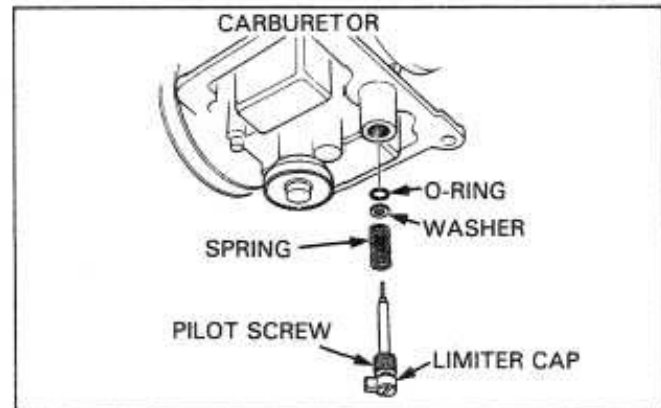

PILOT SCREW ADJUSTMENT

IDLE DROP PROCEDURE (4 stroke, multi-carburetor, emissions control applicable models)

NOTE

- Make sure the carburetor synchronization is within specification before pilot screw adjustment.
- The pilot screws are factory pre-set and no adjustment is necessary unless the pilot screws are replaced.
- Use a tachometer with graduations of 50 rpm or smaller that will accurately indicate a 50 rpm change.

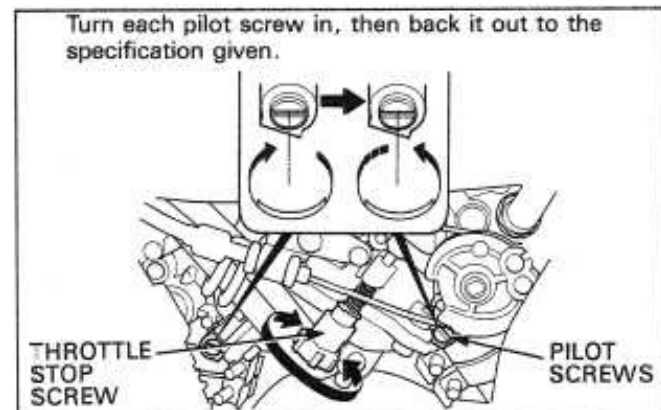

1. Turn each pilot screw clockwise until it seats lightly, then back it out to the specification given. This is an initial setting prior to the final pilot screw adjustment.

INITIAL OPENING: Refer to the Model Specific manual.

CAUTION

- Tightening the pilot screw against its seat will damage the seat.

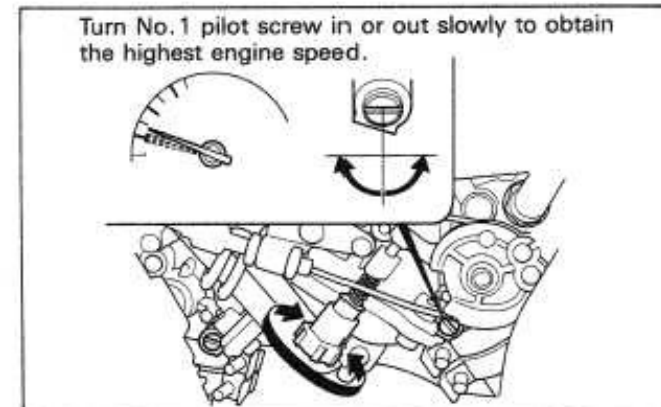

2. Warm up to the engine to operating temperature. Stop and go riding for 10 minutes is sufficient.
3. Attach a tachometer according to its manufacturer's instructions.
4. Adjust the idle speed to the specified rpm with the throttle stop screw.

IDLE SPEED: Refer to the Model Specific manual.

5. Turn No. 1 carburetor pilot screw in or out slowly to obtain the highest engine speed.
6. Perform step 5 for all the carburetor pilot screws.
7. Lightly open the throttle 2–3 times, then adjust the idle speed with the throttle stop screw.
8. Turn No. 1 carburetor pilot screw in gradually until the engine speed drops 50 rpm.

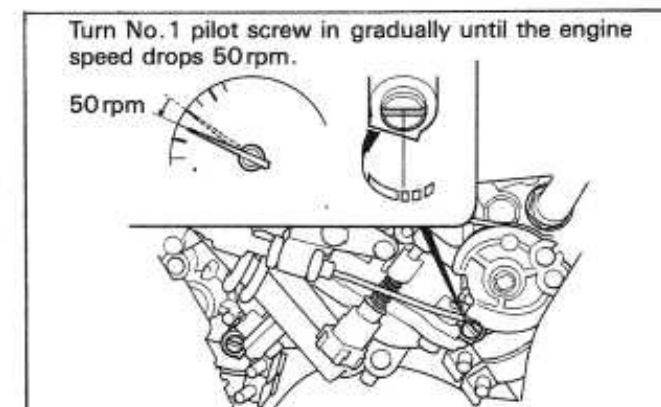

- Turn No.1 carburetor pilot screw counterclockwise to the final opening from the position in step 8.

FINAL OPENING: Refer to the Model Specific manual

- Perform steps 8 and 9 for all the carburetor pilot screws.
- Make sure that the engine acceleration in relation to throttle opening.
- Install the new limiter cap (or plug) onto the pilot screw head (page 8-23).

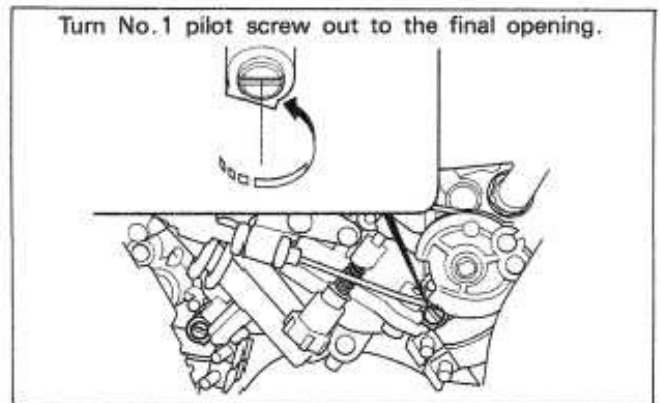

IDLE DROP PROCEDURE (4 stroke, single carburetor, emissions control applicable models)

NOTE

- The pilot screw is factory pre-set and no adjustment is necessary unless the pilot screw is replaced.
- Use a tachometer with graduations of 100 rpm or smaller that will accurately indicate a 100 rpm change.

- Turn pilot screw clockwise until it seats lightly, then back it out to the specification given. This is an initial setting prior to the final pilot screw adjustment.

INITIAL OPENING: Refer to the Model Specific manual.

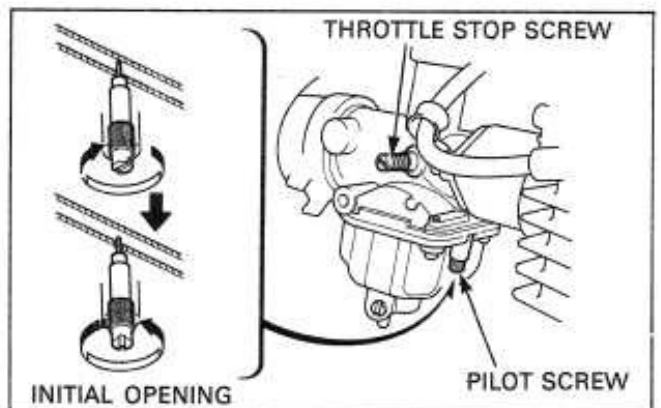

CAUTION

- Tightening the pilot screw against its seat will damage the seat.

- Warm up the engine to operating temperature. Ten minutes of stop and go driving is sufficient.
- Attach a tachometer according to its manufacturer's instructions.
- Adjust the idle speed with the throttle stop screw.

IDLE SPEED: Refer to the Model Specific manual.

- Turn the pilot screw in or out slowly to obtain the highest engine speed.
- Readjust the idle speed with the throttle stop screw.
- Turn the pilot screw in gradually until the engine speed drops 100 rpm (50 rpm on some models.)

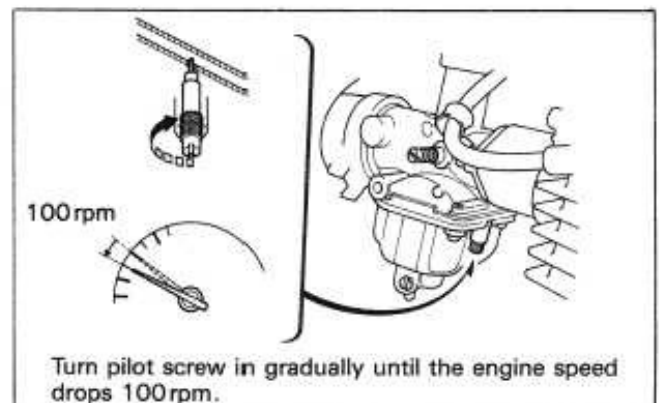
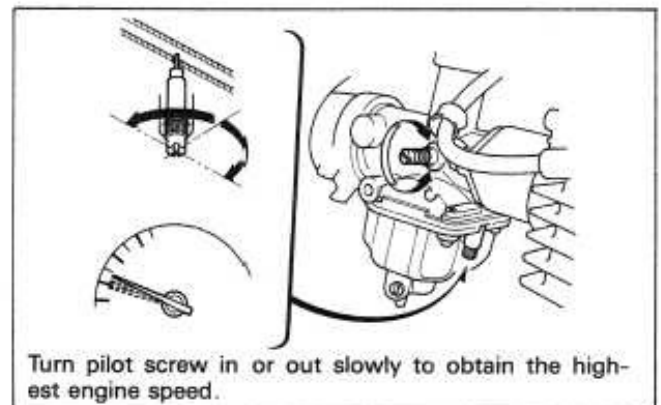

FUEL SYSTEM

- Turn the pilot screw counterclockwise the number of turns specified in the Model Specific manual.
- Readjust the idle speed with the throttle stop screw.
- Install the new limiter cap (or plug) onto the pilot screw head (page 8-23).

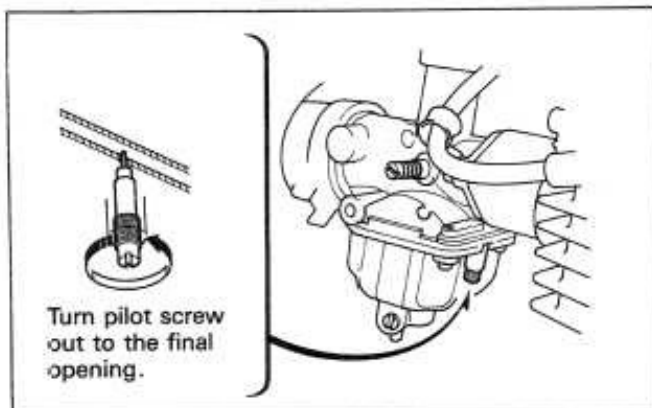

AIR SCREW OR PILOT ADJUSTMENT

BEST IDLE PROCEDURE (4 stroke, all models)

NOTE

- The air or pilot screw is factory pre-set. Adjustment is not necessary unless the carburetor is overhauled or a new air or pilot screw is installed.

CAUTION

- Tightening the air or pilot screw against its seat will damage the seat.

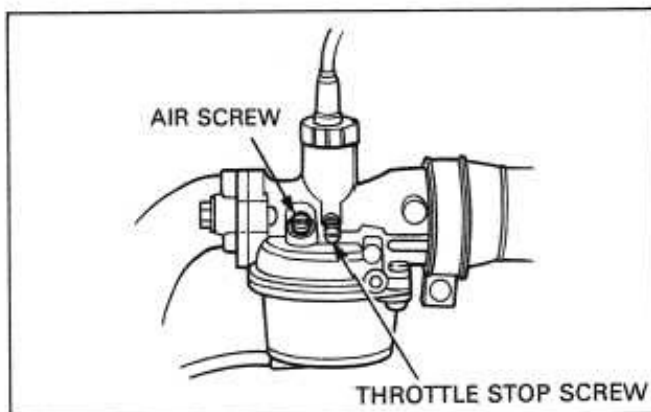

- Turn the air or pilot screw clockwise until it seats lightly, then back it out to the specification given. This is an initial setting prior to the final air or pilot screw adjustment.

AIR OR PILOT SCREW OPENING: Refer to the Model Specific manual.

- Warm up the engine to operating temperature. Ten minutes of stop and go driving is sufficient.
- Stop the engine and connect a tachometer.
- Start the engine and adjust the idle speed with the throttle stop screw.

IDLE SPEED: Refer to the Model Specific manual.

- Turn the air or pilot screw in or out slowly to obtain the highest engine speed.
- Readjust the idle speed to the specified value with the throttle stop screw.
- Make sure that the engine does not miss or run erratically. Repeat steps 5 and 6 until engine speed increases smoothly.
- Readjust the idle speed with the throttle stop screw.
- Install the limiter cap (or plug) on to the air or pilot screw head (if applicable). (page 8-23).

AIR SCREW ADJUSTMENT (2-stroke engine only)

Warm the engine up to operating temperature.

Turn the air screw clockwise until it seats lightly, then back it out to the specification given.

AIR SCREW OPENING: Refer to the Model Specific manual.

CAUTION

- Tightening the air screw against its seat will damage the seat.

Adjust the idle speed with the throttle stop screw.

IDLE SPEED: Refer to the Model Specific manual.

Rev the engine up slightly from the idle speed and make sure that engine speed rises and returns smoothly.

Adjust by turning the air screw in or out within a 1/4 turn if necessary. If the engine cannot be adjusted by turning the air screw within a 1/4 turn, check for other engine problems.

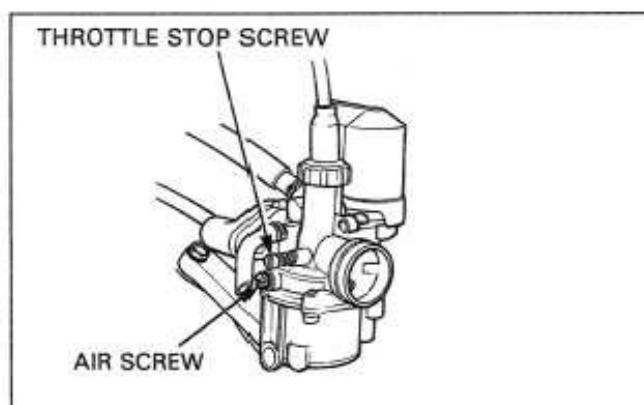

LIMITER CAP (OR PLUG) INSTALLATION

LIMITER CAP

If the pilot screw (or air screw) is removed, a new limiter cap must be installed after the screw is adjusted.

After adjustment, cement the limiter caps over the screws, using LOCTITE® 601 or equivalent. The limiter cap should be placed against its stop as shown preventing further adjustment that would enrich the fuel mixture.

Pilot screw: the limiter cap position permits clockwise rotation and prevents counterclockwise rotation.

Air screw: the limiter cap position permits counterclockwise rotation and prevents clockwise rotation.

NOTE

- Do not turn the pilot screw (or air screw) when installing the limiter cap.

LIMITER PLUG

Drive new pilot screw (or air screw) plug into the pilot screw (or air screw) bore with a 7 mm valve guide driver (P/N 07942-8230000).

When fully seated the plug surface will be recessed 1 mm.

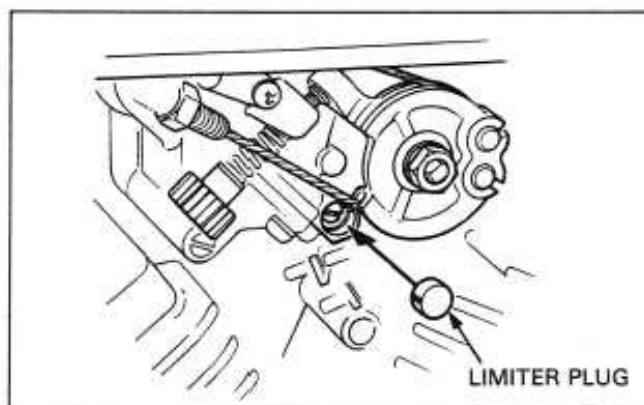
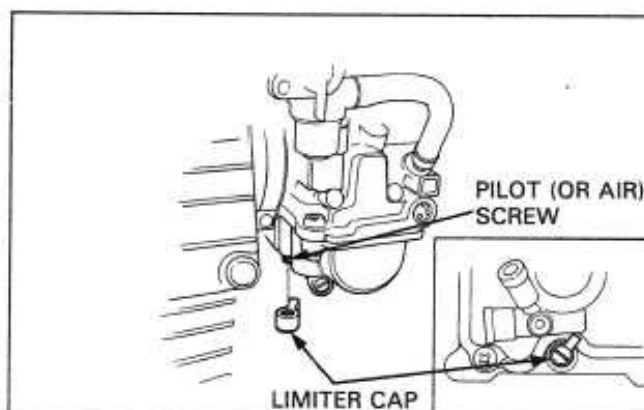

FUEL SYSTEM

ACCELERATOR PUMP ADJUSTMENT

NOTE

- Accelerator pump adjustment is not necessary unless the adjusting screw is replaced.

Adjust the idle speed.

Adjust the throttle grip free play.

Measure the clearance between the accelerator pump rod and pump arm.

CLEARANCE: Refer to the Model Specific manual.

If the clearance is not within specification, adjust the clearance by carefully bending the pump arm or by turning the adjusting screw. (Refer to the Model Specific manual.)

HIGH ALTITUDE ADJUSTMENT (U.S.A. only)

When the vehicle is to be operated continuously above 6,500 feet (2,000 m) the carburetor must be readjusted as follows to improve driveability and decrease exhaust emission.

Warm up the engine to operating temperature. Ten minutes of stop and go driving is sufficient.

Turn the pilot screw clockwise to the specified opening (or turn the air screw counterclockwise to the specified opening.)

Refer to the Model Specific manual for standard and high altitude setting.

NOTE

- This adjustment must be made at high altitude to ensure proper high altitude operation.
- On some models the standard main jet must be replaced with an optional, smaller high altitude jet.

Attach a Vehicle Emission Control Information Update Label in the location specified in the label position illustration. (Refer to the Model Specific manual for the specified position.)

NOTE

- Do not attach the label to any part that can be easily removed from the vehicle.

▲ WARNING

- Operation at an altitude lower than 5,000 feet (1,500 m) with the carburetors adjusted for high altitudes may cause the engine to idle roughly and the engine may stall in traffic.

When the vehicle is to be operated continuously below 5,000 feet (1,500 m), turn the pilot screw counterclockwise (the air screw clockwise) to its original position and reinstall the standard main jet (as necessary), and adjust the idle speed to the specified rpm. Remove the vehicle emission control update label.

Be sure to make these adjustments at low altitude.

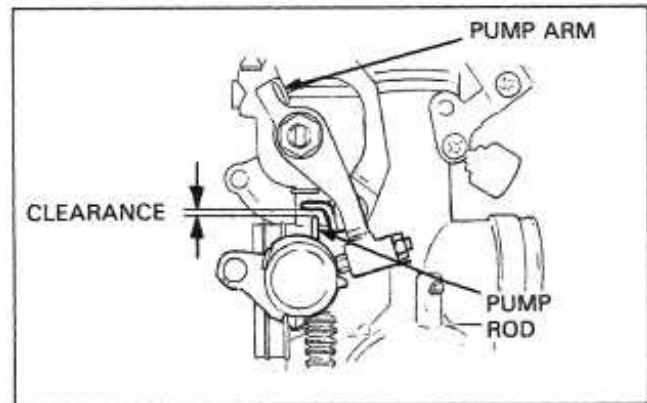

VEHICLE EMISSION CONTROL UPDATE LABEL

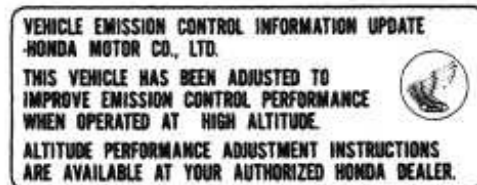

9. CYLINDER HEAD

SERVICE INFORMATION	9-1	CYLINDER HEAD DISASSEMBLY	9-12
TROUBLESHOOTING	9-1	VALVE SPRINGS	9-12
SYSTEM DESCRIPTION	9-2	VALVES	9-12
HYDRAULIC TAPPETS	9-5	VALVE GUIDES	9-13
DECOMPRESSOR SYSTEM	9-7	VALVE SEATS	9-15
CAMSHAFT	9-9	CYLINDER HEAD ASSEMBLY	9-18
ROCKER ARM, ROCKER ARM SHAFT	9-10	INITIAL CAMSHAFT LUBRICATION	9-19
CYLINDER HEAD INSPECTION	9-11		

SERVICE INFORMATION

- Refer to Engine Testing, section 3, for cylinder compression and leak-down testing.
- Remove accumulated carbon from the cylinder head of two-stroke engines as described in the Model Specific manual.
- Camshaft lubricating oil is fed through oil passages in the cylinder head. Clean the oil passages before assembling the cylinder head.
- Clean all disassembled parts with cleaning solvent and dry them by blowing them off with compressed air before inspection.
- Before reassembly, lubricate the sliding surfaces of the parts (see each Model Specific manual for lubrication).
- When disassembling, mark and store the disassembled parts to ensure that they are reinstalled in their proper locations.
- Loosen the cylinder head bolts in a crisscross pattern in two or three steps from outside to center and from small diameter to large diameter.
- When tightening cylinder head bolts:
 - tighten the bolts and nuts to the specified torque in the sequence described in Model Specific manual, or if the sequence is not described, tighten according to the following general rule.
 - hand-tighten the bolts and nuts, then torque large bolts and nuts before small ones in a crisscross pattern from inner-to-outer in two or three gradual steps.
- If it is no longer clear which bolt belongs in which hole, insert all bolts in the holes and check the exposed lengths; each should be exposed the same amount.

9

TROUBLESHOOTING

Engine top-end problems usually affect engine performance. These can be diagnosed by a compression or leak down test, or by tracing noises to the top-end with a sounding rod or stethoscope.

Low compression

- Valves
 - Incorrect valve adjustment (see section 2)
 - Burned or bent valves
 - Incorrect valve timing
 - Broken valve spring
 - Uneven valve seating
- Cylinder head
 - Leaking or damaged head gasket
 - Warped or cracked cylinder head
- Cylinder, piston (see section 10)
- Leaking crankcase primary compression (2-stroke engine)
 - Blown crankcase gasket
 - Damaged crankshaft oil seal

Excessive white smoke (4-stroke engine)

- Worn valve stem or valve guide
- Damaged stem seal

Rough idle

- Low cylinder compression
- Incorrect decompression adjustment

Compression too high

- Excessive carbon build-up on piston or combustion chamber

Excessive noise

- Incorrect valve adjustment
- Sticking valve or broken valve spring
- Damaged or worn camshaft
- Loose or worn cam chain
- Worn or damaged cam chain tensioner
- Worn cam sprocket teeth
- Worn rocker arm and/or shaft

Kick starting difficult

- Incorrect decompressor adjustment
- Seized engine

SYSTEM DESCRIPTION

CONSTRUCTION

As cylinder heads are subject to high combustion heat and pressure, they are made of a one-piece aluminum casting with considerable strength and cooling capability. Air-cooled engines are provided with air cooling fins, and liquid-cooled engines with a water jacket to cool the engine.

The cylinder head encloses a combustion chamber. A hemisphere shape is most common, providing a minimum possible space, for improved combustion efficiency. Where four valves per cylinder are used in a 4-stroke engine, the combustion chamber is shaped like a shed roof, according to the valve arrangement.

Some models, of both 2 and 4-stroke engines, are provided with squish areas on the outer circumference of the combustion chamber. This has the effect of improving combustion efficiency at the final stage of the compression process by extra compression of the air/fuel mixture in the squish areas between the piston and cylinder head, forcing the air/fuel mixture to the center of the combustion chamber. There is also the added advantage of decreased carbon adhesion.

The construction of the 2-stroke engine cylinder head is simple. Four-stroke engines, however, have a complicated configuration containing extra parts, due to the necessity of valve actuating mechanisms and exhaust ports. Furthermore, since the intake/exhaust port configuration of a four-stroke engine has a direct relation to engine performance, it is preferable to design these models with very direct inlet for a smoother air/fuel mixture by aligning the intake port from the carburetor to the combustion chamber.

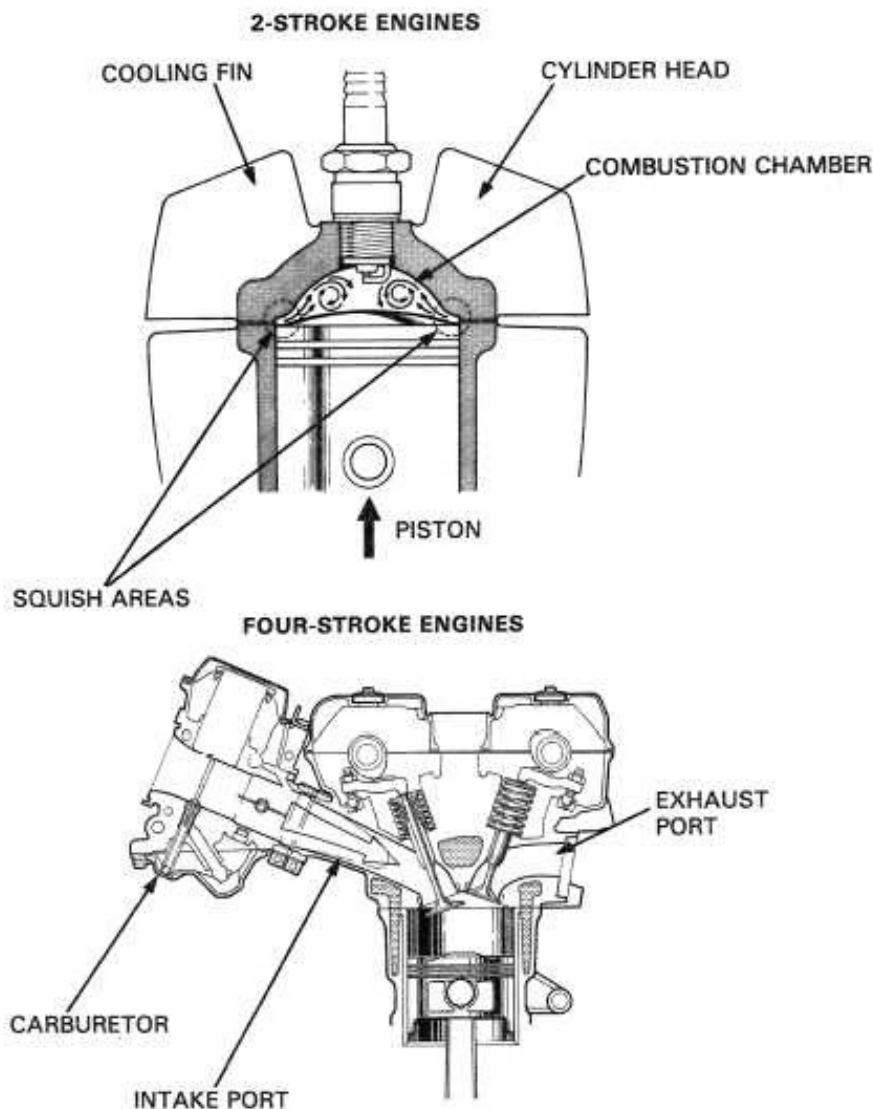

VALVE TRAIN

The current valve train designs used on four-stroke engines are divided into 3 types: a conventional chain drive, a belt drive (with considerable noise reduction), and a gear drive for high performance engines.

A chain drive is the most commonly used mechanism for current valve train design. Its simple construction allows for lower manufacturing costs. Some maintenance is required, however, because eventually chain elongation increases chain noise. Chain maintenance is not required with types using an "automatic cam chain tensioner". The automatic cam chain tensioner provides spring support by pressing the chain in the direction of tension and locking against any counter-pressure. This provides the automatic elimination of chain slack.

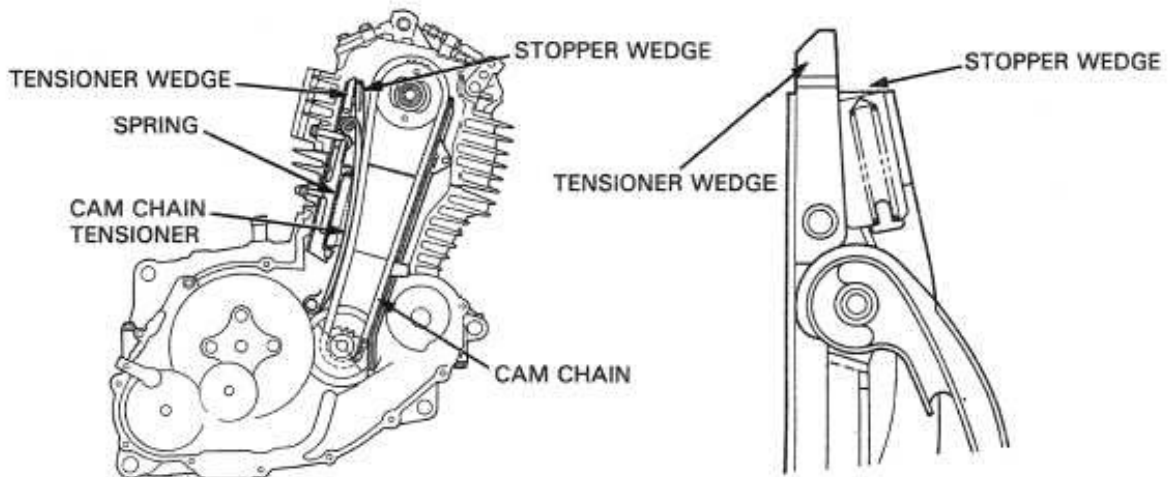

The GOLDWINGS adopt a belt drive system similar to that used on Honda automobiles. This type is used on engines requiring less noise.

There are also models adopting valve drive by gear. This type has minimal friction loss from valve drive and maintains accurate valve timing even at high engine speeds. Accordingly, this type is adopted for sport machines. The camshaft drive gear mechanism between the crankshaft and the camshaft is of a cassette type, allowing easier mounting/removal of the camshaft and gear case in comparison to the chain drive.

Both belt drive and gear drive types require no maintenance and provide reliable strength and durability.

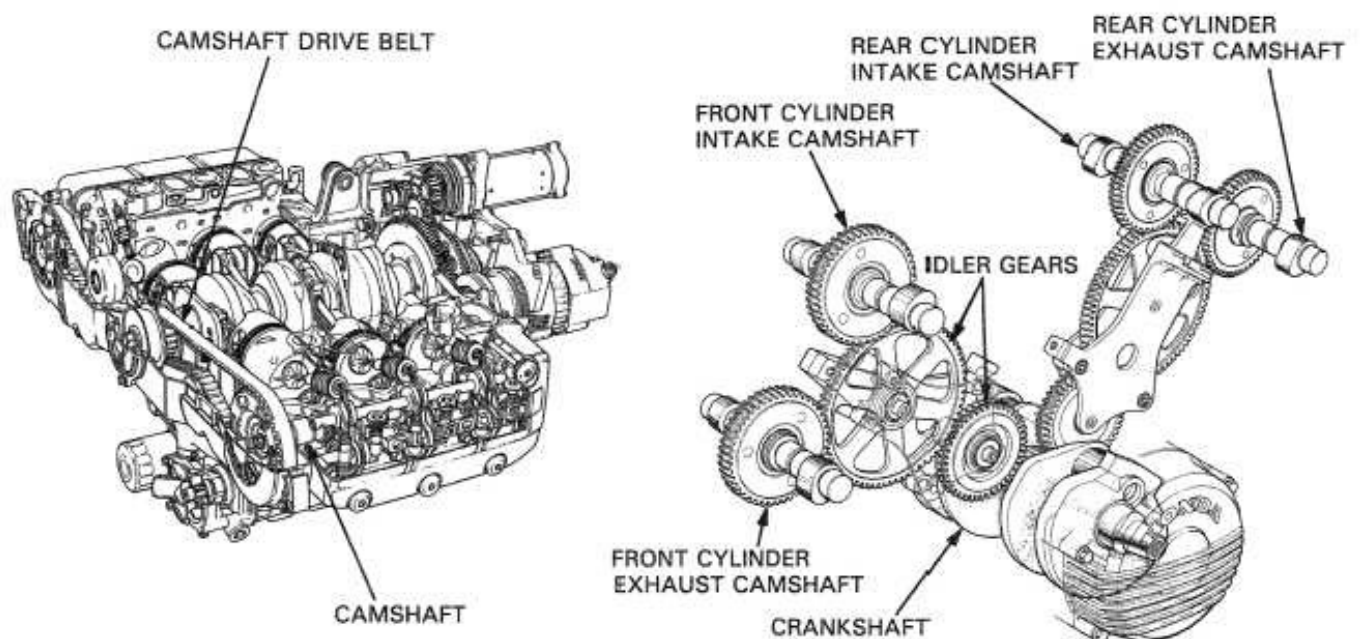

CYLINDER HEAD

VALVE LIFTER MECHANISM/ARRANGEMENT

The current camshaft arrangement in 4-stroke engines can be divided into Single Over Head Camshaft (SOHC) and Double Over Head Camshaft (DOHC) configurations.

The SOHC follows the basic design of 4-stroke engines, operating IN and EX valves through rocker arms with one camshaft. Compared to the DOHC, the SOHC type is less expensive to manufacture and is easier to maintain due to the reduced number of parts. However, "valve jump" (where the valve cannot accurately follow the cam when the engine rotates at high speed) can occur, causing the valve to contact the piston, and causing severe engine damage. To decrease valve mass and reduce the possibility of engine damage during high engine speeds, 4-stroke engines requiring high power generally use the DOHC design in which the valves are operated directly with two separate camshafts for IN and EX valves.

The DOHC configuration can be of two designs: a type pressing the valve bucket directly, or a type lifting the valve through the use of a rocker arm. For the former, a shim is provided in the bucket for valve clearance adjustment. The valve clearance is adjusted by replacing the shim. The shim is usually provided between the bucket and the cam lobe.

Some types have a small shim inserted between the under side of the bucket and the valve stem, allowing less valve actuating mechanism weight.

Some DOHC types are also equipped with rocker arms, allowing easier adjustment of valve clearance.

The DOHC has a further advantage when combined with the 4-valves per cylinder engine type. A larger valve area can be provided in the 4-valve type in comparison to that of the 2-valve type, enabling a greater intake volume of air/fuel mixture and a smoother exhaust. Valve weight is also less, consequently reducing the likelihood of valve jump associated with high engine speeds. Furthermore, with a 4-valve type the spark plug can be placed at the center of the combustion chamber, allowing an easy flame propagation balance during combustion.

EXAMPLE OF SOHC-4 VALVE SYSTEM

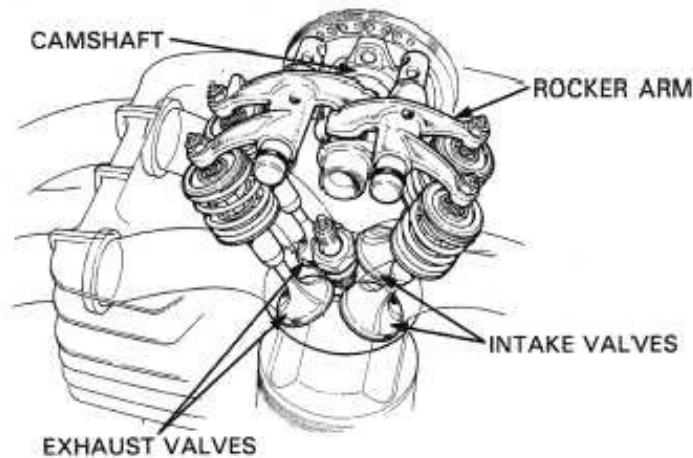

EXAMPLE OF DOHC WITH VALVE BUCKET TYPE

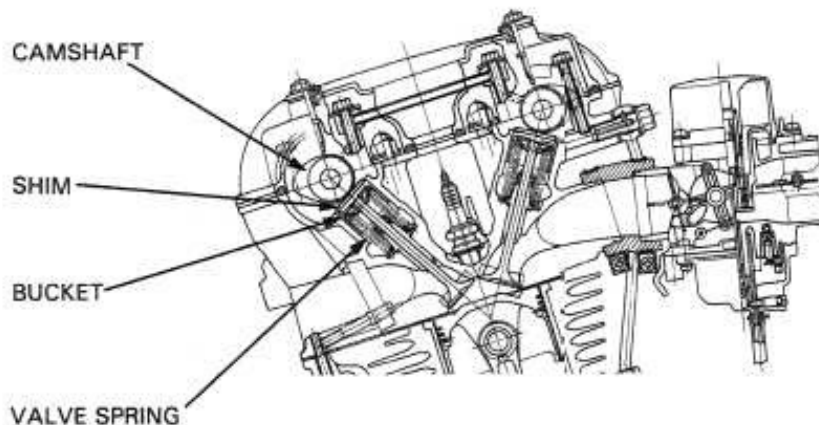

HYDRAULIC TAPPETS

GENERAL

Hydraulic tappets do not require adjustment and help the engine to run quieter by keeping valve clearance at zero at all engine temperatures.

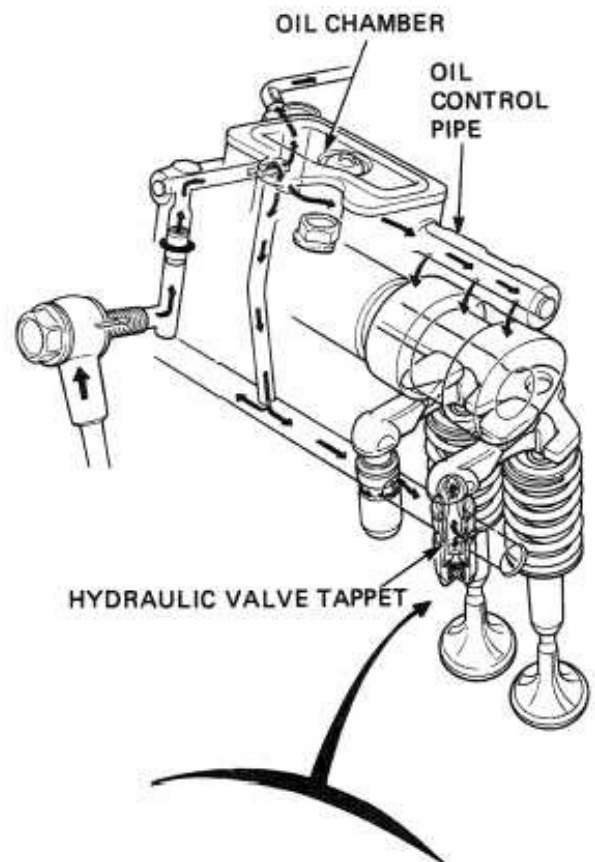

OPERATION

When the camshaft lobe does not push the rocker arm the tappet plunger is at rest. In this position its oil inlet hole aligns with the tappet body oil inlet hole. Oil enters the tappet reservoir through these holes.

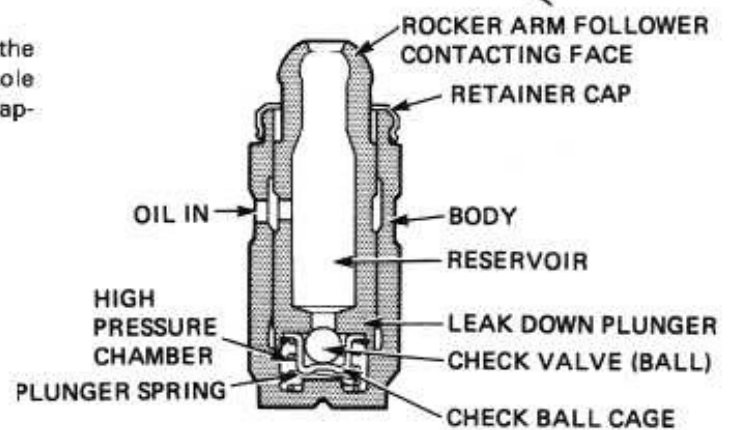

CYLINDER HEAD

As the camshaft turns and pushes on the rocker arm slipper, the rocker arm pushes the tappet plunger down and oil pressure in the tappet high pressure chamber increases causing the check valve to close. During the short time it takes the check valve to close, a small amount of oil leaks out of the chamber causing the tappet to compress.

As the cam lobe continues to push on the rocker arm, oil pressure in the high pressure chamber increases rapidly (because the check valve is closed). The high oil pressure keeps the tappet from compressing any further which then allows the rocker arm to pivot and open the engine valve. As the cam lobe nears maximum lift, oil pressure in the high pressure chamber becomes high enough to cause a very small amount of oil to leak out of the high pressure chamber between the plunger and body. This allows the plunger to absorb the shock from the effects of the cam lobe reaching maximum lift.

After the cam lobe passes maximum lift, the engine valve springs force the engine valve to close.

When the valve closes completely, the plunger is pushed up by the spring in the high pressure chamber. Oil pressure decreases and as a result the check valve opens and allows oil to re-enter the high pressure chamber from the reservoir.

All of the above actions keep valve clearance at zero under all normal operating conditions.

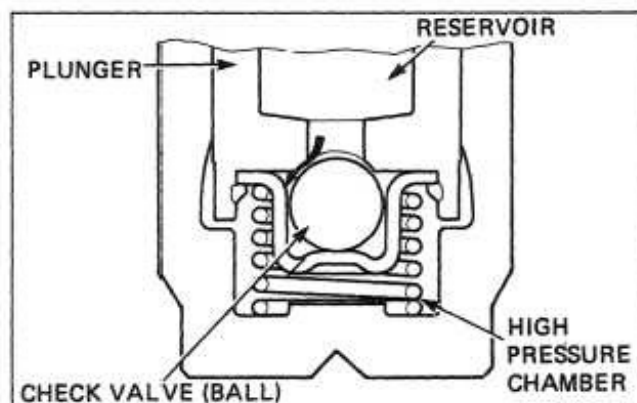
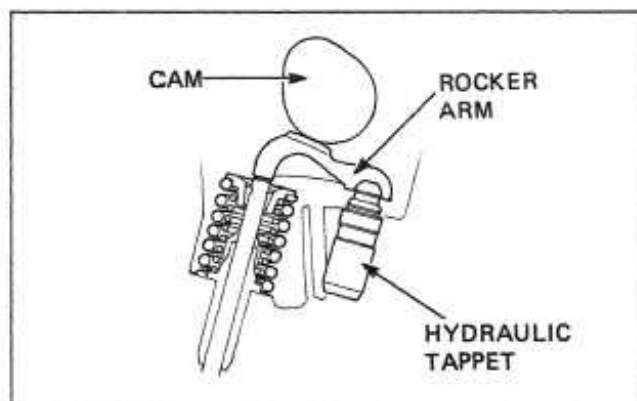
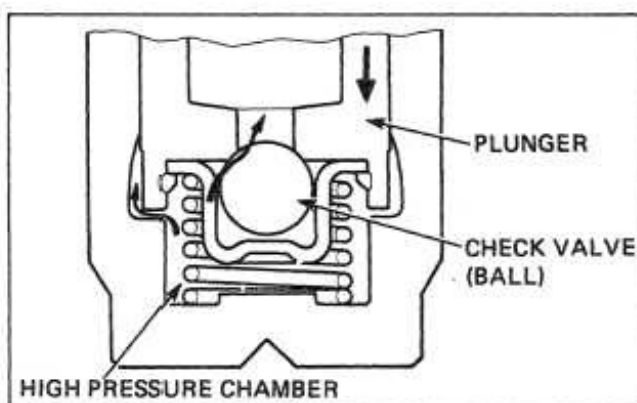

DECOMPRESSOR SYSTEM

Description

The decompressor which eases the required starting force and also reduces starting kickback. This system is used on all 1988 4-stroke singles of 250 cc and larger engines. It is more compact and lighter than previous systems and is maintenance free. On the XR600R, it reduces the required starting force to that of a 250 cc engine.

Construction

The system uses two separate decompressor cams: one is for reducing the necessary kickover force (decompressor cam) and the other reduces starting kickback (reverse decompressor cam). Both of these decompressor cams slip onto the drive end of the camshaft. The decompressor cam is loosely keyed onto the camshaft which allows it to shift positions as the engine speed increases (after startup). The reverse decompressor cam rotates on a machined surface on the camshaft but it can only rotate in one direction because of a one-way roller bearing.

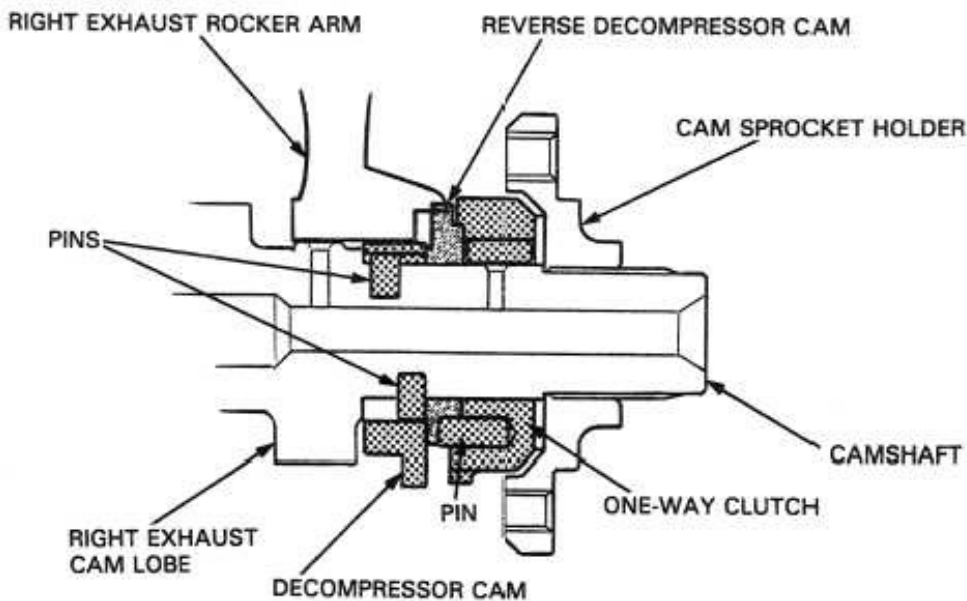

FUNCTION

Decompressor cam

At TDC (on compression) the right exhaust rocker arm is contacting the normal cam lobe's heel (concentric circle) so that valve is closed, as would be normal. But the decompressor cam opens the exhaust valve a slight amount to reduce kickstarting force. After the engine starts, centrifugal force moves the position of the decompressor cam and it becomes flush with the normal cam lobe's heel.

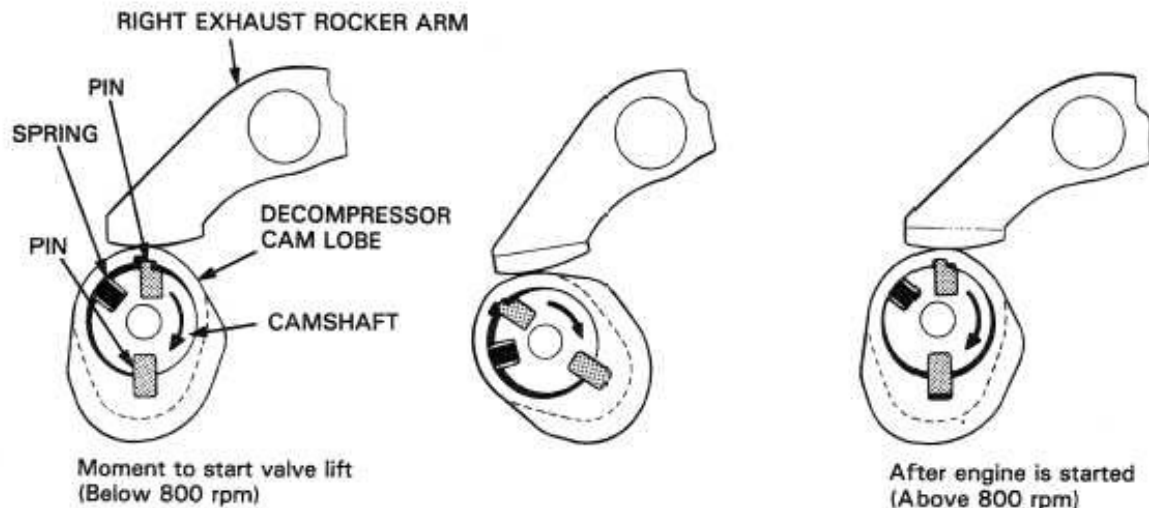

CYLINDER HEAD

Reverse decompressor cam

The reverse decompressor cam is stationary during normal engine operation. It doesn't turn when the engine is being started or when it is running. Its one-way roller bearing allows it to free-wheel whenever the engine is turning in the normal direction.

But if the engine kickbacks during startup, the reverse direction locks-up the one-way roller bearing which moves the lobe of the reverse decompressor cam into position (it opens the exhaust valve). The reverse decompressor cam automatically returns to its normal position when the engine stops turning from the kickback.

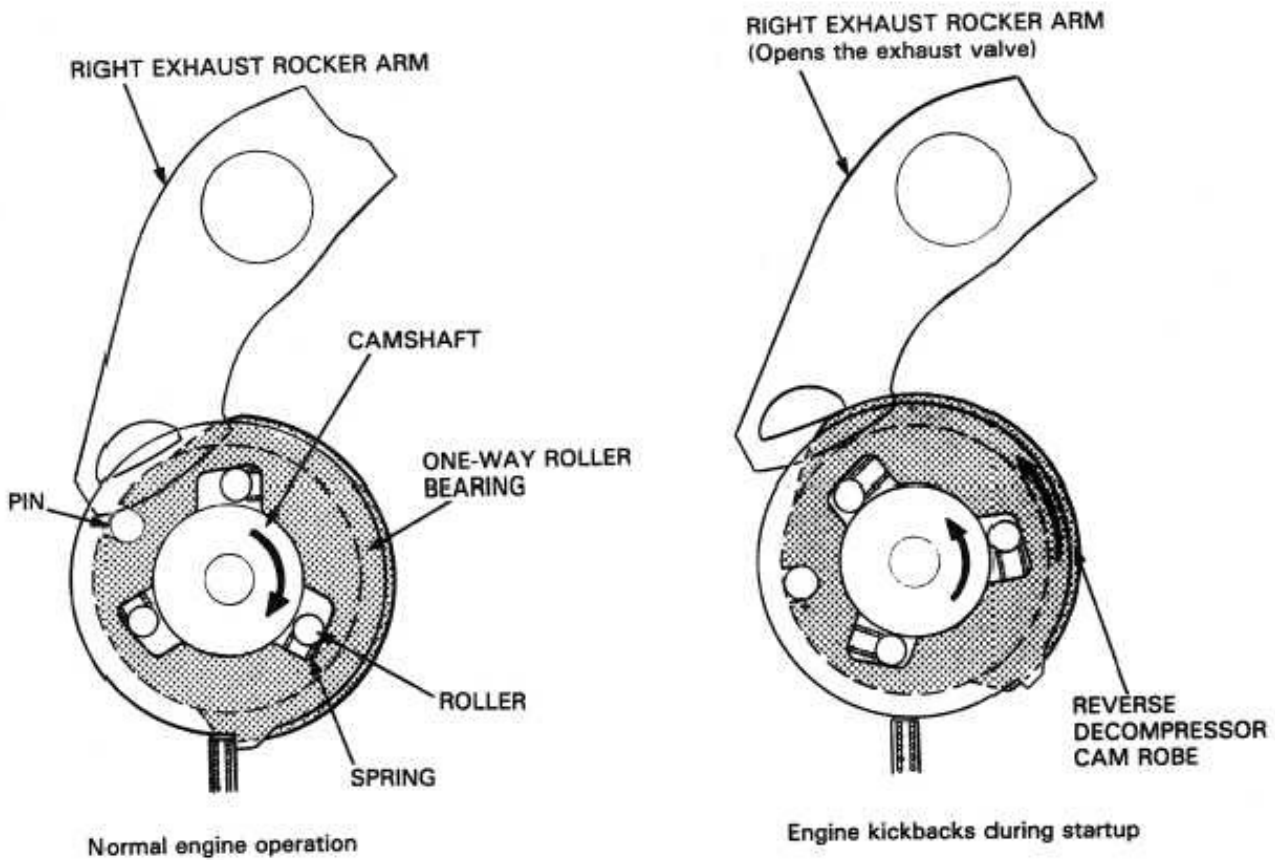

CAMSHAFT

CAMSHAFT INSPECTION

Inspect the cam lobes and replace cams that are worn, scored or scratched.

NOTE

- Inspect the rocker arm if the cam lobe is worn or damaged.

Inspect the journal surfaces. Replace the camshaft if any of the working surfaces are worn, scored or scratched.

NOTE

- Inspect the oil passages and camshaft holders for wear or damage if the journal surface is worn or damaged.

Measure the journal O.D. and cam height. Replace any camshaft if its measurements are beyond the service limits.

Check camshaft runout with a dial indicator.
Support both ends of the camshaft with V-blocks.

Actual runout is 1/2 the total indicator reading.

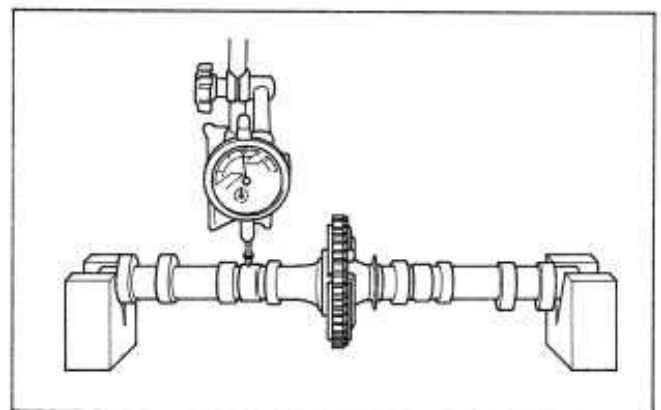
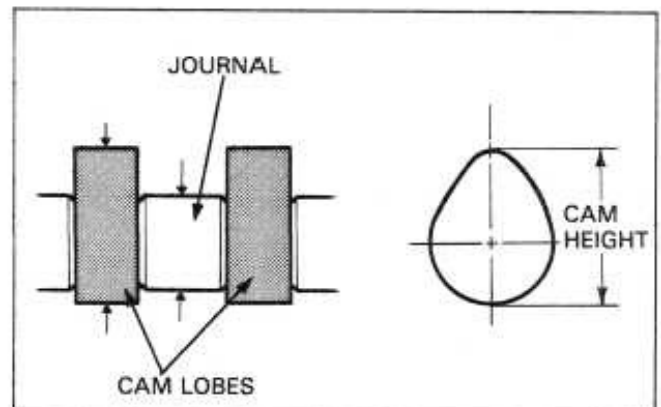

CAMSHAFT BEARING INSPECTION

Check that the bearing inner race fits the camshaft tightly without play.

Turn the outer race and check that the bearing turns smoothly and quietly.

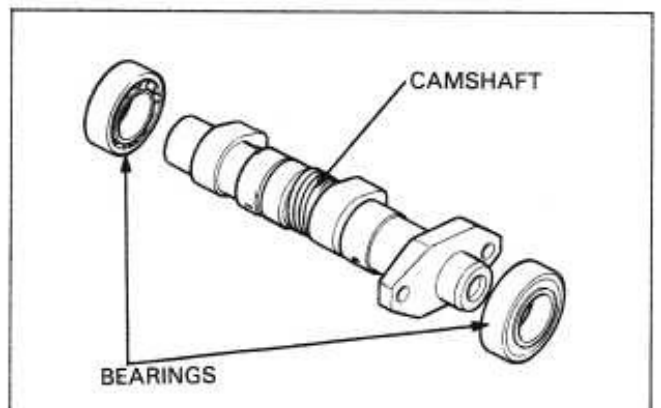

CAMSHAFT OIL CLEARANCE INSPECTION

The oil clearance is the difference between the camshaft holder I.D. and the journal O.D.

Measure the camshaft holder journal I.D. with a dial indicator. Subtract the camshaft journal O.D. from the camshaft holder journal I.D. to obtain the oil clearance.

When the service limits are exceeded, replace the camshaft and recheck the oil clearance.

Replace the cylinder head and camshaft holders if the clearance still exceeds service limits.

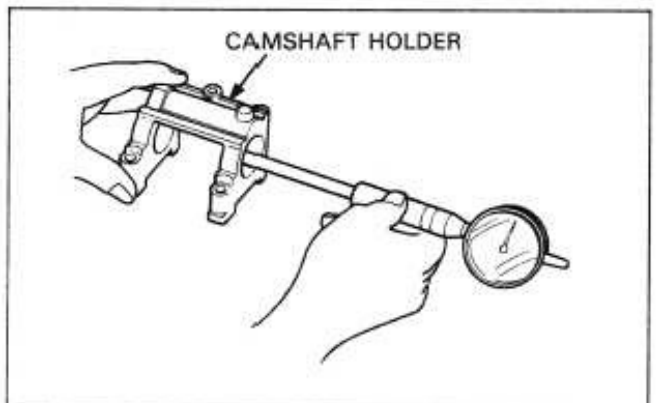

CYLINDER HEAD

If a dial indicator cannot be used, measure the oil clearances using plastigauge:

Clean off any oil from the camshaft journals.

Put the camshaft in the cylinder head and place a strip of plastigauge on top of each camshaft journal.

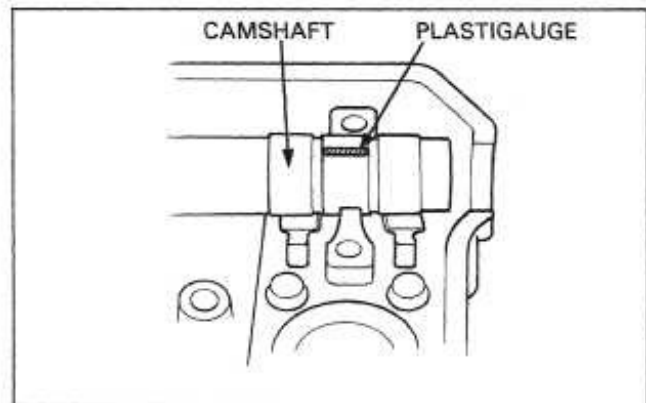

Install the camshaft holders and tighten the mounting bolts to the specified torque. (Refer to the Model Specific manual for the correct torque specification)

NOTE

- Do not rotate the camshaft during inspection.

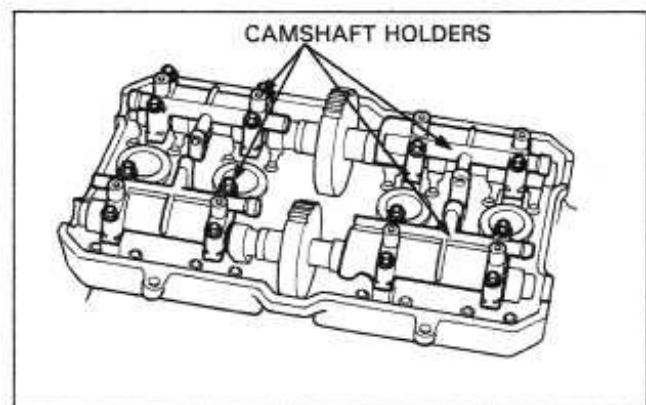

Remove the camshaft holders and measure the width of each plastigauge. The widest thickness determines the oil clearance.

When the service limits are exceeded, replace the camshaft and recheck the oil clearance.

Replace the cylinder head and camshaft holders if the clearance still exceeds service limits.

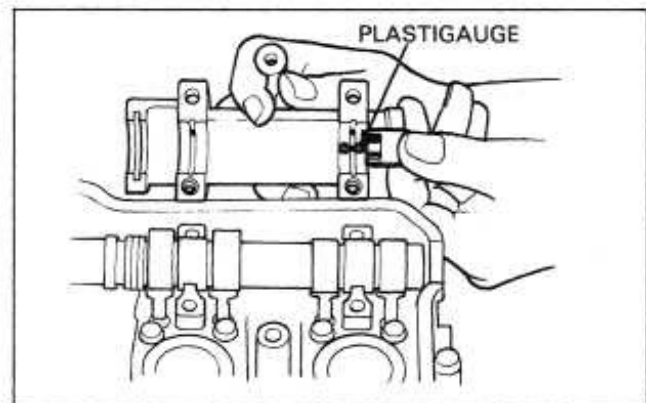

ROCKER ARM, ROCKER ARM SHAFT

Inspect the sliding surface of the rocker arms for wear or damage where they contact the camshaft, or for clogged oil holes.

Measure the I.D. of each rocker arm.
Measure each rocker arm and shaft O.D.

Inspect the shaft for wear or damage and calculate the shaft to rocker arm clearance.

Replace the rocker arm and/or shaft if the measurements exceed the service limits.

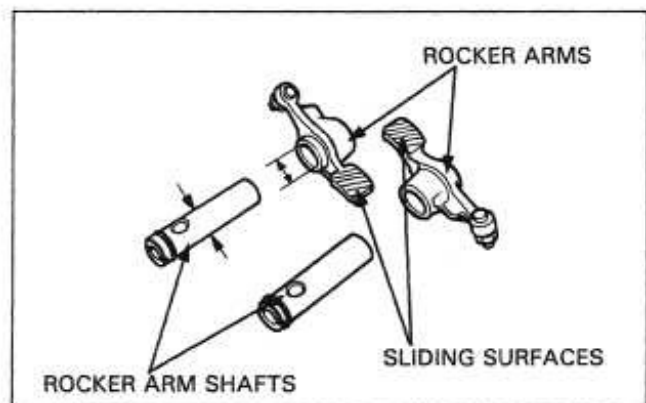

CYLINDER HEAD INSPECTION

SOLVENT TEST

Remove the cylinder head (refer to the Model Specific manual).

Place the cylinder head with the intake port facing up as shown. Pour kerosene into the intake port.

Wait for a few minutes, then check the valve area on the combustion chamber side for kerosene leakage.

With the exhaust port facing up, pour the kerosene into the port as shown. Wait for a few minutes, then check the valve area on the combustion chamber for kerosene leakage.

If kerosene leaks from around the valve, it indicates faulty sealing of the valve seat. Remove the valve from the cylinder head and check the following:

- Valve seat for damage (page 9-11)
- Valve seat contact face (page 9-11)
- Valve stem for bending or damage (page 9-8)

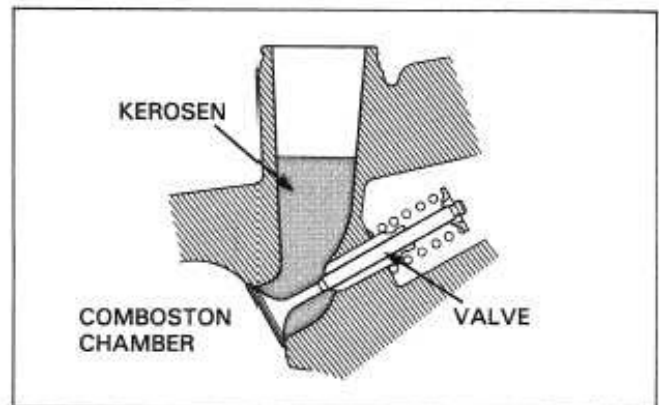

WARPAGE INSPECTION

Remove carbon deposits from the combustion chamber and clean off the head gasket surfaces.

NOTE

- Gaskets will come off easier if soaked in high flash-point cleaning solvent.

CAUTION

- Avoid damaging the gasket and valve seat surfaces.

Check the spark plug hole and valve areas for cracks.

Check the cylinder head for warpage with a straight edge and feeler gauge.

Repair or replace the cylinder head if warpage exceeds the service limit. (Refer to the Model Specific manual)

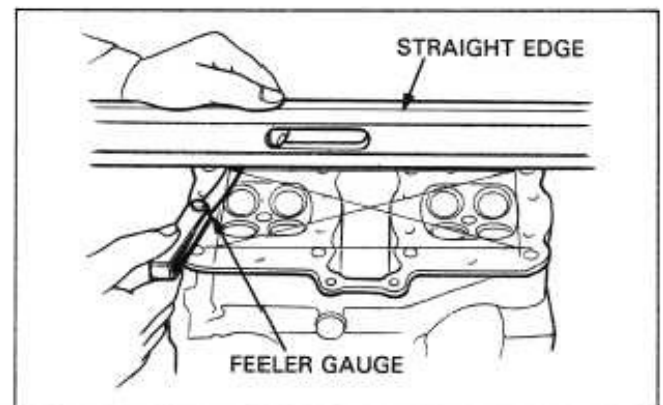

CYLINDER HEAD

CYLINDER HEAD DISASSEMBLY

Remove the cylinder head according to the Model Specific manual.

Remove the valve cotters with the valve spring compressor.

TOOL:
VALVE SPRING COMPRESSOR 07757-0010000 and
ATTACHMENT
(as necessary)

CAUTION

- Compressing the valve springs more than necessary will cause loss of valve spring tension.

Remove the valve spring compressor, then remove the retainers, valve springs and valves.

NOTE

- Mark the valves so they can be replaced in their original positions.

Remove and discard the stem seals if necessary.

NOTE

- Do not reuse the removed stem seal(s).

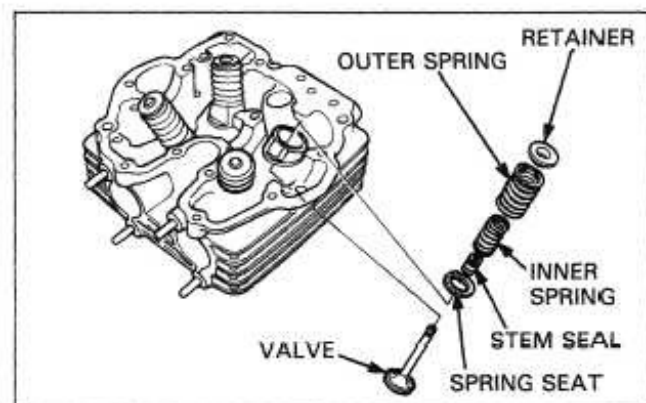
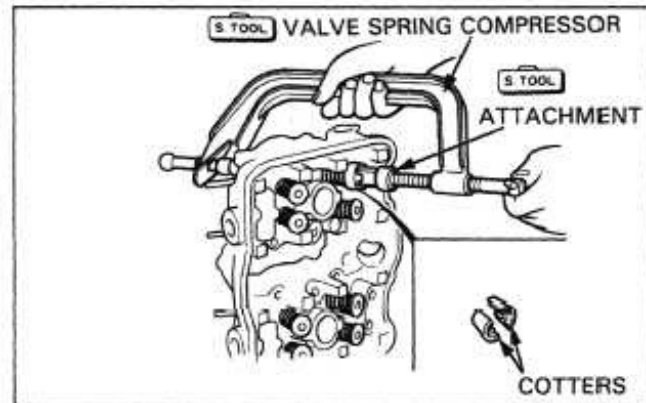

VALVE SPRINGS

Measure the free length of the inner and outer valve springs.

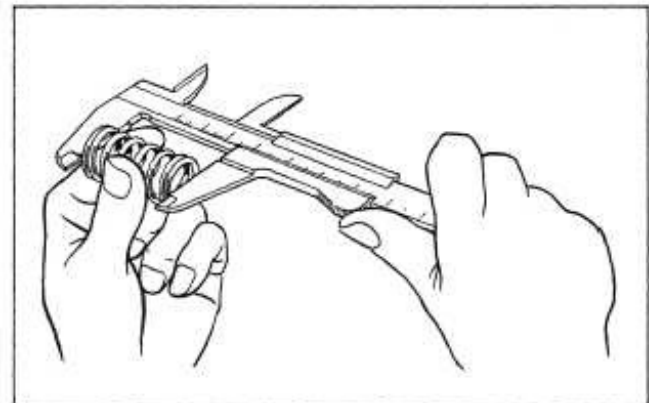

VALVES

Inspect each valve for bending, burning, scratches or abnormal wear.

Insert the valves in their original positions in the cylinder head. Check that each valve moves up and down smoothly, without binding.



Measure and record the valve stem O.D. in three places along the valve guide sliding area.

Replace the valve with a new one if the service limit is exceeded.

VALVE GUIDES

INSPECTION

Insert the valve guide reamer from the combustion chamber side and ream the guide to remove any carbon build-up before measuring the guide.

NOTE

- Take care not to tilt or lean the reamer in the guide while reaming.
- If reaming is irregular, oil will leak past the valve stem seal. It could cause improper seat contact that cannot be corrected by refacing.
- Rotate the reamer clockwise, never counterclockwise when inserting and removing.

Measure and record each valve guide I.D. using a ball gauge or inside micrometer.

STEM-TO-GUIDE CLEARANCE

When using a dial indicator:

Measure the stem-to-guide clearance with a dial indicator while rocking the stem in the direction of normal thrust (wobble method).

REPLACEMENT

NOTE

- Refinish the valve seats whenever the valve guides are replaced to prevent uneven seating.

Flanged Guides:

Chill the valve guides in the freezer section of a refrigerator for about an hour.

Heat the cylinder head to 130°C–140°C (275°F–290°F). Do not heat the cylinder head beyond 150°C (300°F). Use temperature indicator sticks, available from welding supply stores, to be sure the cylinder head is heated to the proper temperature.

CAUTION

- Using a torch to heat the cylinder head may cause warping.

▲ WARNING

- Wear insulated gloves to avoid burns when handling the heated cylinder head.

Support the cylinder head and drive the old guides out of the combustion chamber side of the cylinder head.

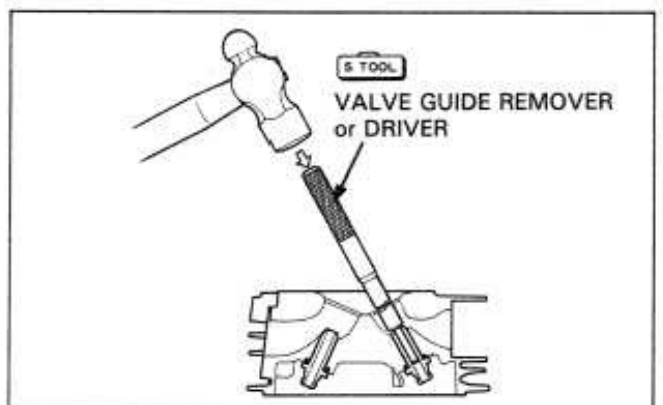
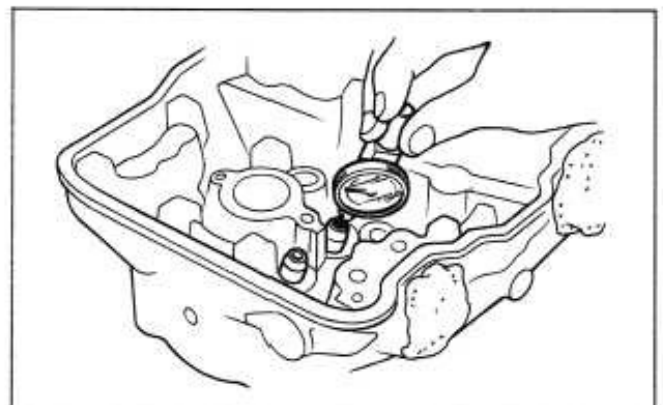
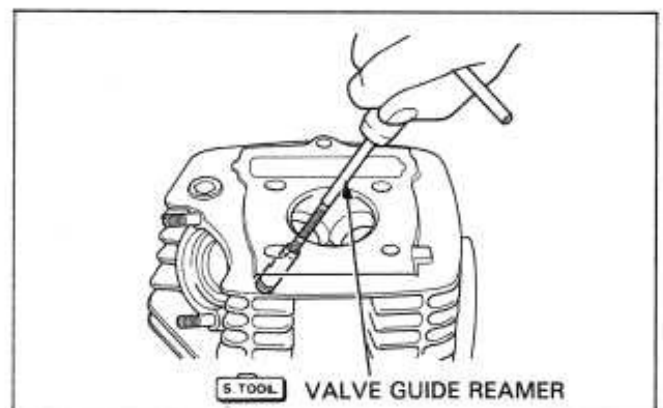
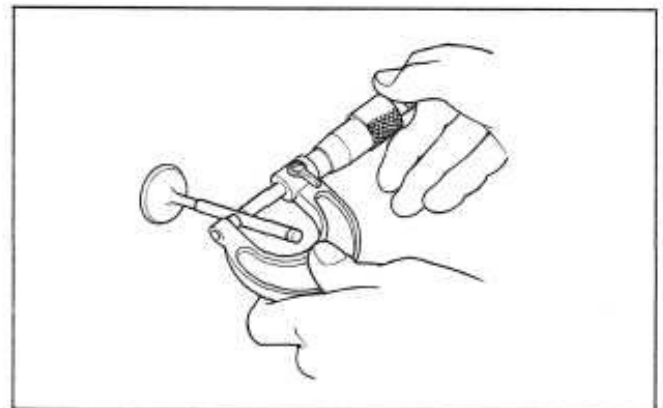

CYLINDER HEAD

CAUTION

- Avoid damaging the head when driving the valve guide out.

Apply oil to a new O-ring and install it onto a new valve guide. Drive the new guide in from the camshaft side of the cylinder head while the cylinder head is still heated.

Let the cylinder head cool to room temperature, then ream the new valve guides.

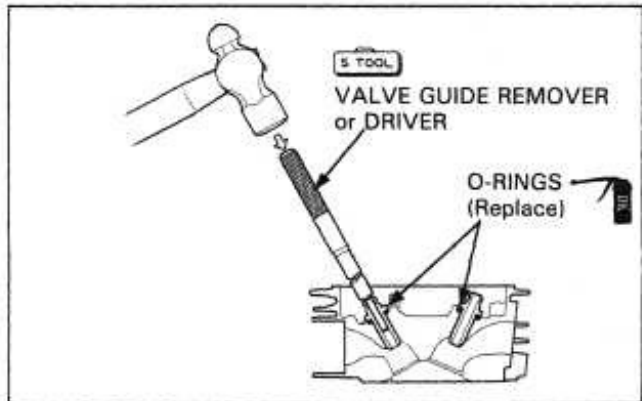

Flangeless Type Guides:

Measure and record the exposed height of the valve guide using a pair of vernier calipers.

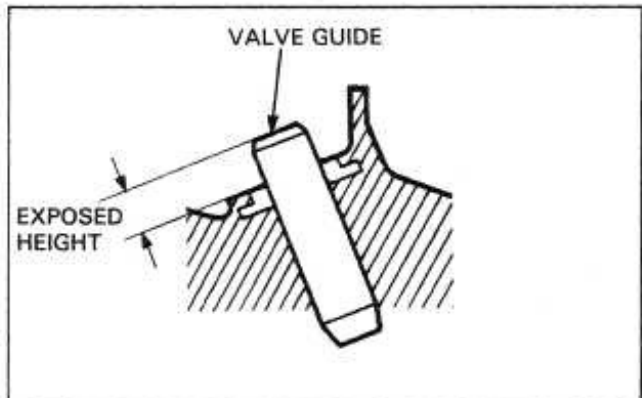

Chill the valve guides in the freezer section of a refrigerator for about an hour.

Heat the cylinder head to 130°C–140°C (275°F–290°F). Do not heat the cylinder head beyond 150°C (300°F). Use temperature indicator sticks, available from welding supply stores, to be sure the cylinder head is heated to the proper temperature.

CAUTION

- Using a torch to heat the cylinder head may cause warping.

WARNING

- To avoid burns, wear insulated gloves when handling the heated cylinder head.

Support the cylinder head and drive the old guides out of the combustion chamber side of the cylinder.

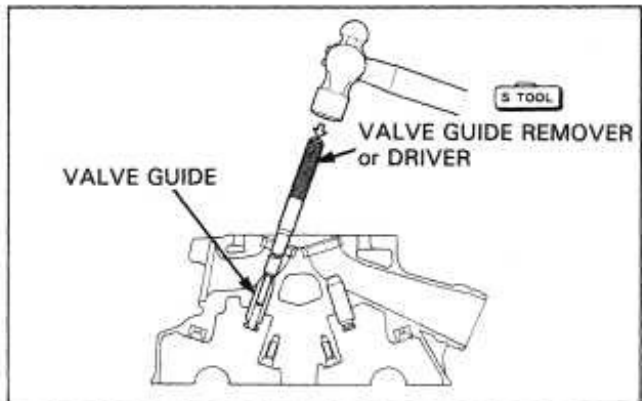

CAUTION

- Avoid damaging the head when driving the valve guide out.

While the cylinder head is still heated, drive a new valve guide in from valve spring side until the exposed height is the same as was measured for the old guide.

Let the cylinder head cool to room temperature and ream the new valve guide.

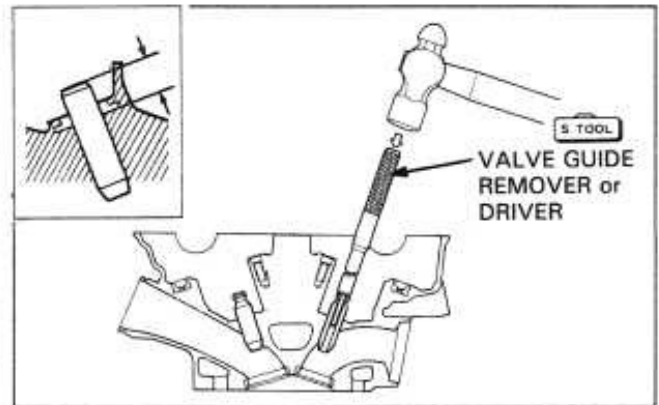

VALVE GUIDE REAMING

When reaming new valve guides, insert the valve guide reamer from the combustion chamber side.

NOTE

- Take care not to tilt or lean the reamer in the guide while reaming.
- If reaming is irregular, oil will leak past the valve stem seal. It could cause improper seat contact that cannot be corrected by refacing.
- Use cutting oil on the reamer during this operation.
- Rotate the reamer clockwise, never counterclockwise when inserting and removing.

Reface the valve seats and clean the cylinder head thoroughly to remove any metal particles.

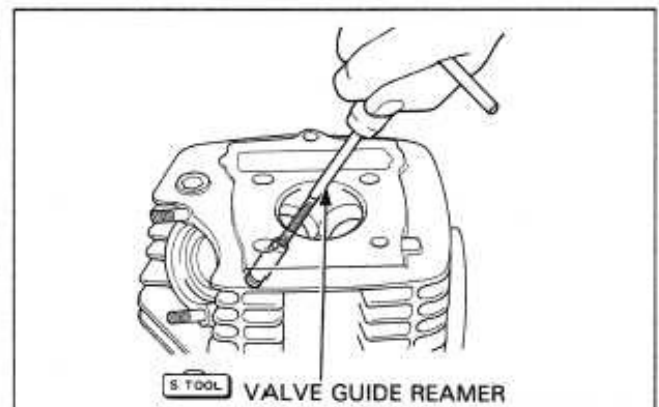

VALVE SEATS

INSPECTION

Clean all intake and exhaust valves thoroughly to remove carbon deposits.

Apply a light coating of Prussian Blue to each valve face.

Tap the valve against the valve seat several times with your finger, without rotating the valve, to check for proper valve seat contact.

Remove the valve and inspect the valve seat face. The valve seat contact should be within the specified width and even all around the circumference. (Refer to the model specific manual for the seat width.)

If the valve seat width is not within specification, reface the valve seat (page 9-12).

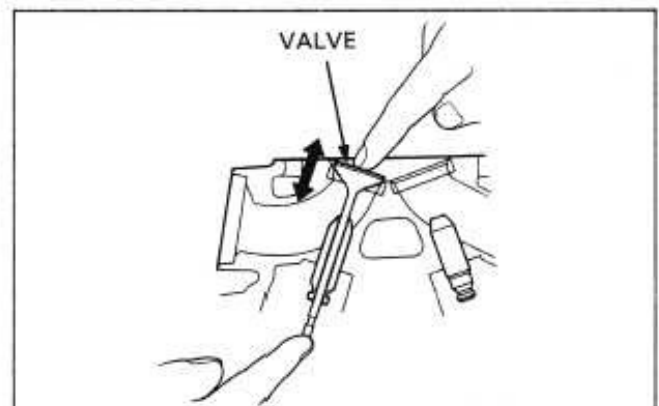

NOTE

- Most valve faces and stem tips are coated with a thin layer of stellite so they cannot be ground. If a valve face or stem tip is rough, worn unevenly, or contacts the seat improperly, the valve must be replaced.

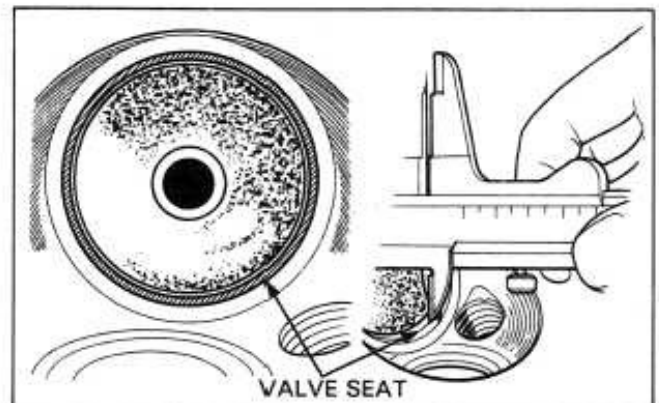

CYLINDER HEAD

Inspect the valve seat face for:

- Uneven seat width:
 - Bent or collapsed valve stem;
Replace the valve and reface the valve seat.
- Damaged face:
 - Replace the valve and reface the valve seat.

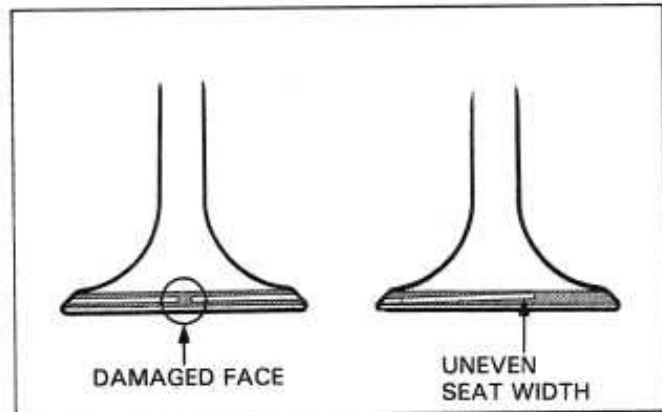

- Contact area (too high or too low).
 - Reface the valve seat.

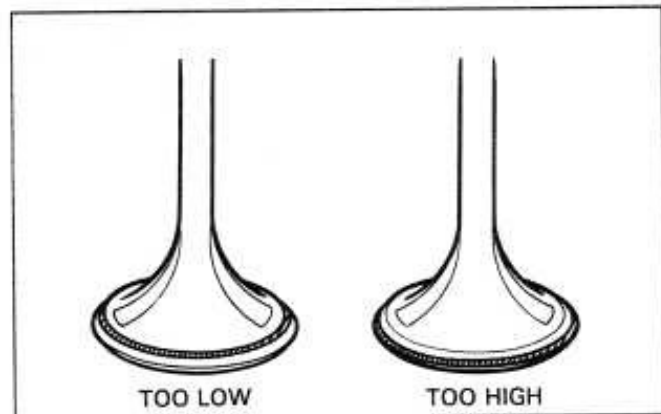

VALVE SEAT REFACING

NOTE

- Follow the refacer manufacturer's operating instructions.
- Reface the valve seat whenever the valve guide has been replaced.
- Be careful not to grind the seat more than necessary.

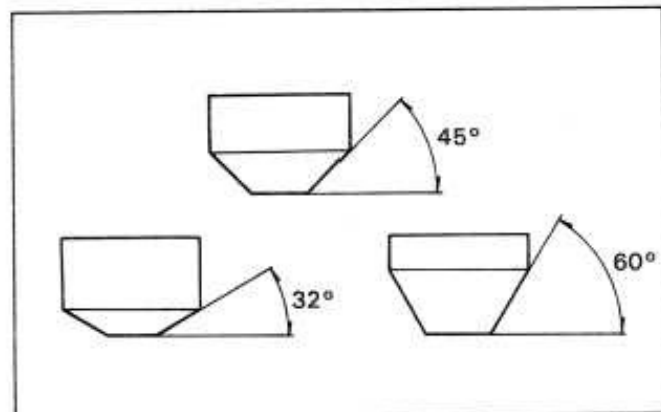

If the contact area is too high on the valve, the seat must be lowered using a 32 degree flat cutter.

If the contact area is too low on the valve, the seat must be raised using a 60 degree inner cutter. Refinish the seat to specifications, using a 45 degree finish cutter.

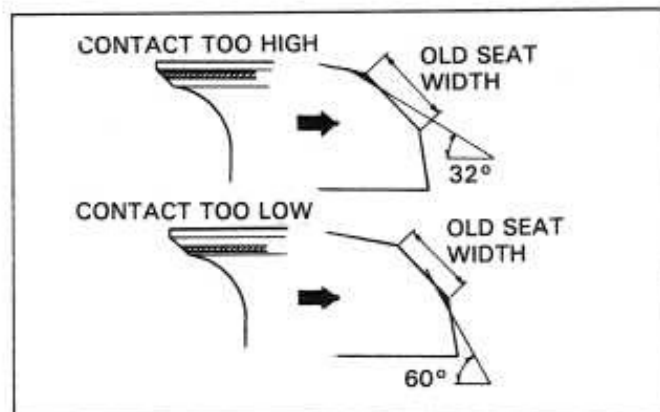

Using a 45 degree cutter, remove any roughness or irregularities from the seat.

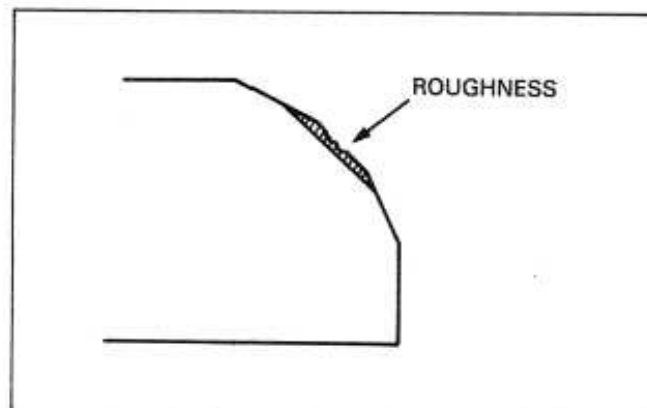

Using a 32 degree cutter, remove 1/4 of the existing valve seat material.

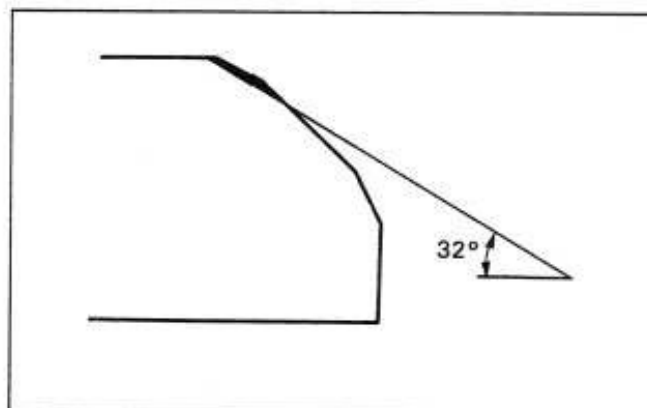

Using a 60 degree cutter, remove the bottom 1/4 of the old seat.

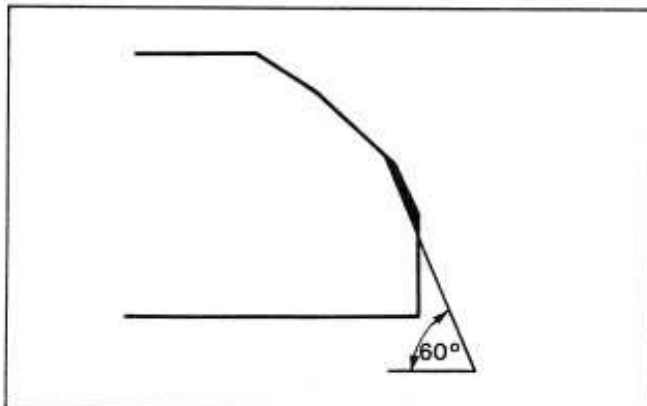

Using a 45 degree cutter, cut the seat to the proper width.

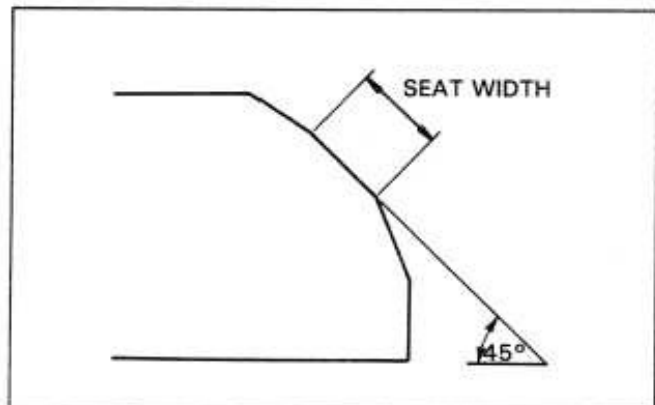

CYLINDER HEAD

After cutting the seat, apply lapping compound to the valve face, and lap the valve using light pressure.

CAUTION

- Excessive lapping pressure may deform or damage the seat.
- Change the angle of lapping tool frequently to prevent uneven seat wear.
- Lapping compound can cause damage if it enters between the valve stem and guide.

After lapping, wash any residual compound off the cylinder head and valve.

Recheck the seat contact after lapping.

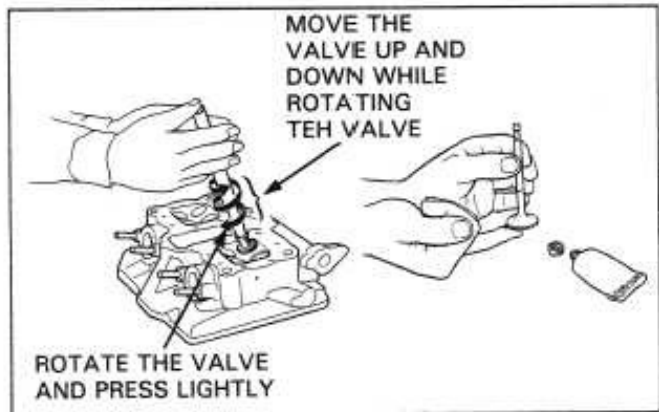

CYLINDER HEAD ASSEMBLY

Install new stem seals.

NOTE

- Replace the stem seals with new ones whenever a stem seal is removed.

Lubricate each valve stem with molybdenum disulfide grease and insert the valve into the valve guide while slowly turning the valve.

CAUTION

- To avoid damage to the stem seals, turn each valve when inserting.

Install the spring seats, valve springs and retainers.

NOTE

- If the valve springs have a varying pitch, install the springs with the narrow pitch end facing down.

Compress the valve springs with the valve spring compressor and install the valve cotters.

CAUTION

- Compressing the valve spring more than necessary when installing the valve cotters may cause loss of valve spring tension.

NOTE

- To ease installation of the cotters, grease them first.

Tap the valve stems gently with a soft hammer to firmly seat the cotters.

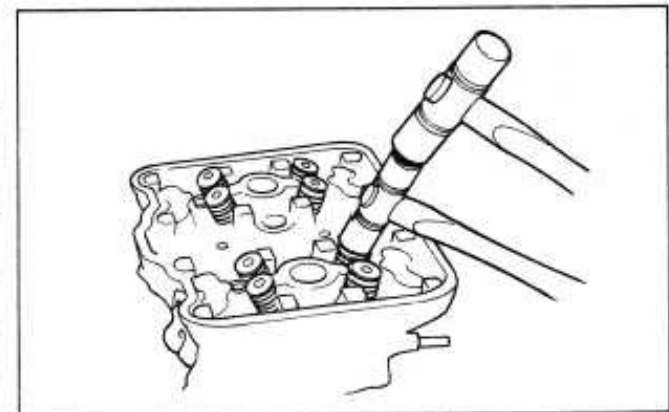
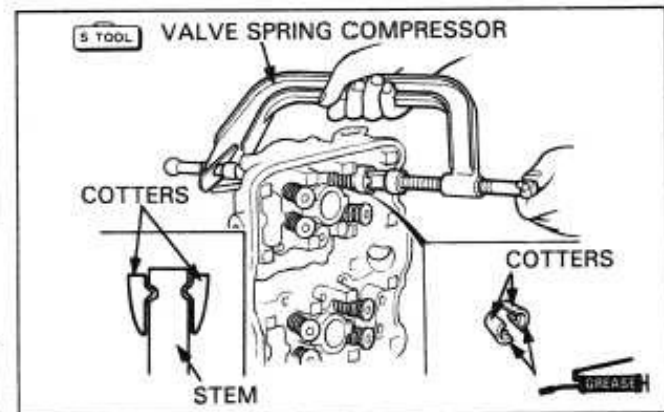
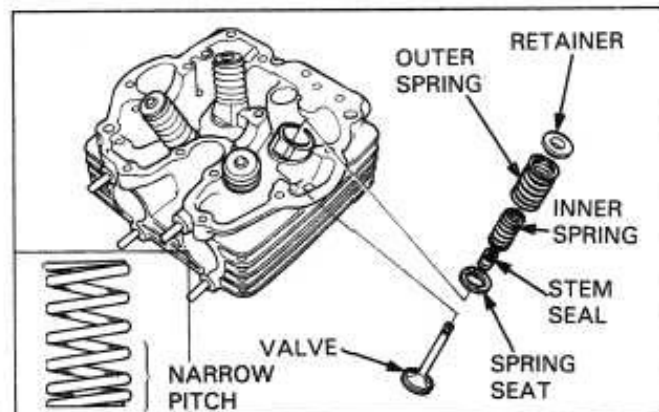

Clean any gasket material from the cylinder mating surface.
Reface the mating surface using oil stone, if necessary.

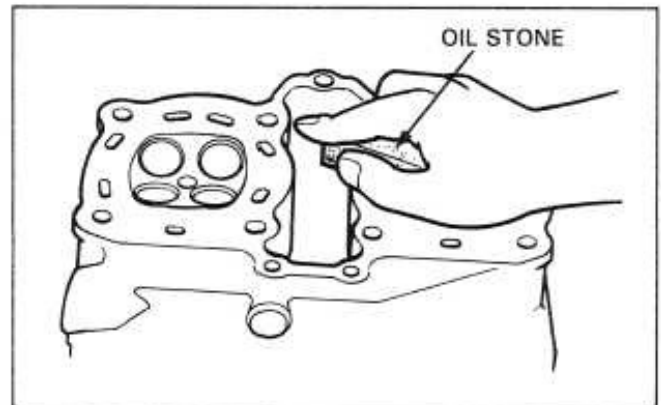

INITIAL CAMSHAFT LUBRICATION

Apply molybdenum disulfide oil to the camshaft journal surfaces in the cylinder head.

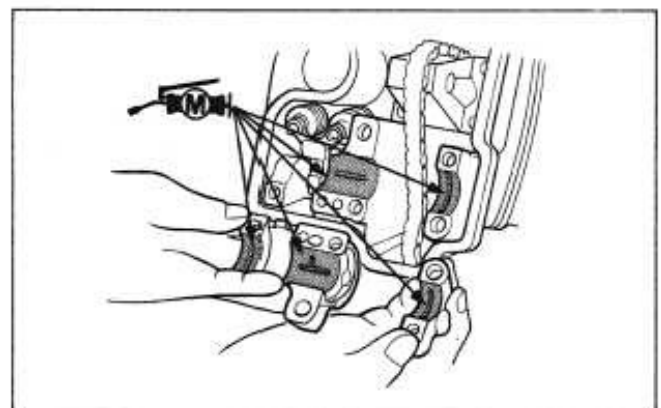

Fill the oil pockets in the head with the recommended oil.

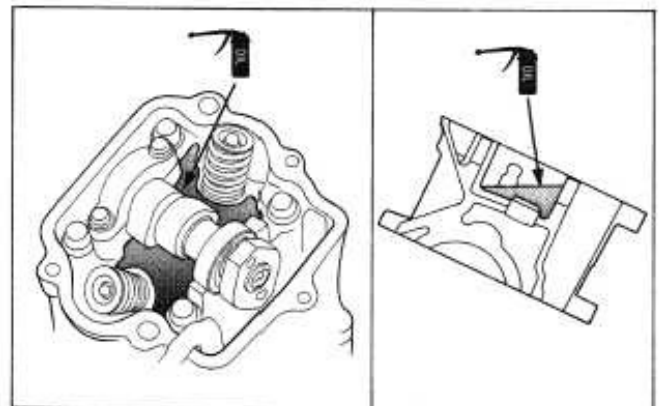

MEMO

10. CYLINDER/PISTON

SERVICE INFORMATION	10-1	CYLINDER	10-5
TROUBLESHOOTING	10-1	PISTON/PISTON RING	10-6
SYSTEM DESCRIPTION	10-2	CYLINDER INSTALLATION	10-10

SERVICE INFORMATION

- Be careful not to damage the mating surfaces by using a screwdriver when disassembling the cylinder. Do not strike the cylinder too hard during disassembly, even with a rubber or plastic mallet, to prevent the possibility of damage to the cylinder fins.
- Take care not to damage the cylinder wall and piston.
- With multi-cylinder engines, store the pistons, piston rings and piston pins in the same order they were installed so they can be reinstalled in the original positions.

TROUBLESHOOTING

Four stroke engines: If performance is poor at low speeds, check for white smoke in the crankcase breather tube. If the tube is smokey, check for a seized piston ring.

NOTE

- Refer to section 3 for cylinder compression and leak-down test procedures.

Compression too low, hard starting or poor performance at low speed

- Leaking cylinder head gasket
- Loose spark plug
- Worn, stuck or broken piston rings
- Worn or damaged cylinder and piston

Compression too high, overheating or knocking

- Excessive carbon build-up in cylinder head or on top of piston

Excessive smoke

- Worn cylinder, piston, or piston rings
- Improper installation of piston rings
- Scored or scratched piston or cylinder wall

Abnormal noise (piston)

- Worn cylinder and piston
- Worn piston pin or piston pin hole
- Worn connecting rod small end bearing

10

SYSTEM DESCRIPTION

CYLINDER

Because the cylinders are afflicted by combustion heat and pressure, they are made of a one-piece aluminum or steel casting with considerable strength and cooling abilities. Air-cooled engines are provided with cooling fins and liquid-cooled engines are provided with a water jacket; both necessary to cool the engine. With a 4-stroke engine, the cylinder wall has cylindrical shape. With the 2-stroke engine, however, the exhaust or scavenging ports are open and the characteristics of the engine depend on the shape, location and size of the ports. These ports are the key parts of a 2-stroke engine. Because the piston rings and piston skirts move against the cylinder walls, a material with high wear resistance is required. For the aluminum cast cylinder, a steel cylinder sleeve is pressed into the part that directly contacts the piston and rings. In some 2-stroke engines, the cylinder walls are plated with special hard metal (nickel-silicon carbide coating which is much lighter than the sleeve type), and which has considerable cooling ability, seizure and wear resistance.

With the sleeve type, the cylinder wall is honed for a finish. Fine grooves are made in the surface to collect and spread the oil on the cylinder wall to lubricate the piston. With the plated type, neither modification of the cylinder wall nor reboring is possible. If the cylinder wall is flawed the cylinder must be replaced.

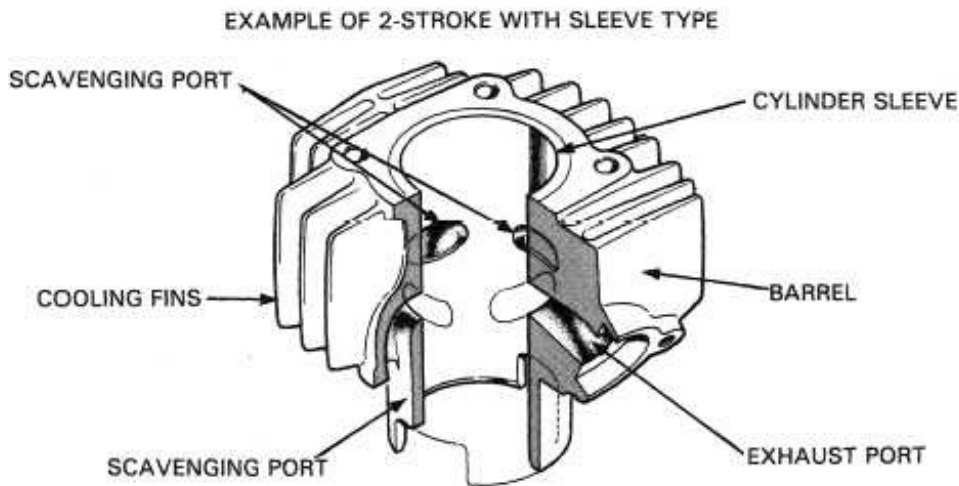

EXAMPLE OF 2-STROKE ENGINE PROCESSED WITH NICKEL-SILICON CARBIDE (Nikasil®)

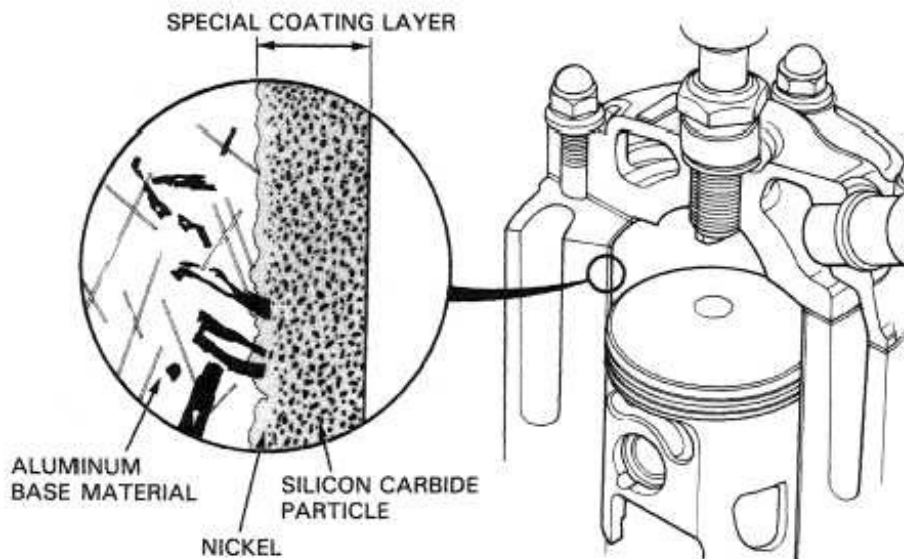

PISTON

The piston moves at high speed in the cylinder, and is exposed to the extreme temperature of combustion. Pistons are therefore made of a specially forged light alloy type aluminum, which is not only lightweight but also less susceptible to thermal expansion.

The piston itself is a high temperature part, being cooled only by the release of heat to the cylinder through the inhaled air/fuel mixture and the piston ring. The piston head is therefore fabricated to have a somewhat smaller outer diameter than the skirt, due to the high temperature exposure and large thermal expansion. With a 2-stroke engine, the cylinder is distorted and the clearance with the piston tends to partially decrease, as there are two different parts with unequal thermal expansion in the cylinder: a part cooled by the air/fuel mixture around the piston, such as the scavenging port, and a part exposed to the extreme heat near the exhaust port. To resolve this problem the piston head of the 2-stroke engine is oval and designed to have appropriate clearance during driving.

At the small end of the connecting rod of the 2-stroke engine, a needle bearing is used. For the 4-stroke engine, however, a plain bearing is used at this point.

The reciprocating motion of the piston is converted into a rotational motion of the crankshaft through the connecting rod. To smooth the motion conversion, the pin hole of the piston is slightly offset against the center shaft of the crankshaft.

If the piston is assembled in an incorrect direction, the piston strikes the cylinder wall due to reversed offset, causing rapid wear or seizure.

To assemble the offset correctly, the assembly must be done by following the marks indicating the piston head assembly direction.

PISTON RING

4-STROKE

The piston rings are inserted within the grooves in the piston. Rings are made of a material with considerable wear resistance, because the piston rings move at high speed with the piston while being pressed against the cylinder wall by their own tension.

The ring arrangement for the 4-stroke engine is with two compression rings sealing the combustion gas and a pair of oil rings removing the oil from the cylinder wall.

Although the two compression rings are similar in appearance, they are different in detail. Therefore, when removed, their installation position must be noted and marked before storing to prevent incorrect reassembly. If identification is difficult, the difference in shapes should be remembered; the top ring is usually plain and the second ring has a beveled edge. Most of the top rings are chrome plated on their sliding surface in order to increase wear resistance. A few second rings are, however, also plated.

Piston rings for 4-stroke and 2-stroke engines have identification marks near the end gap of the top and second rings. These ring marks must face upwards on the piston when assembling.

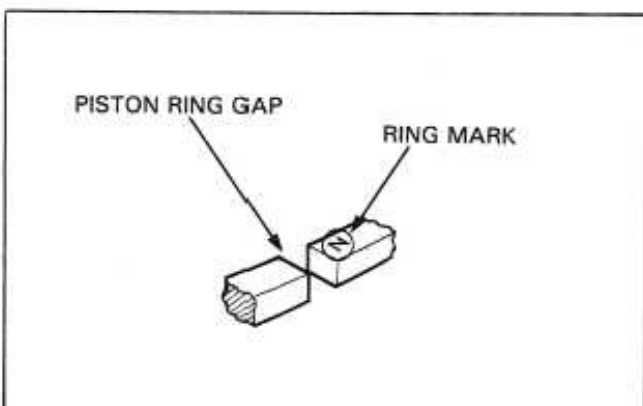
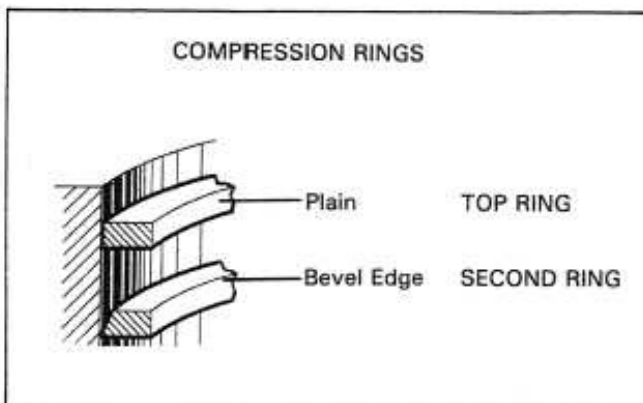
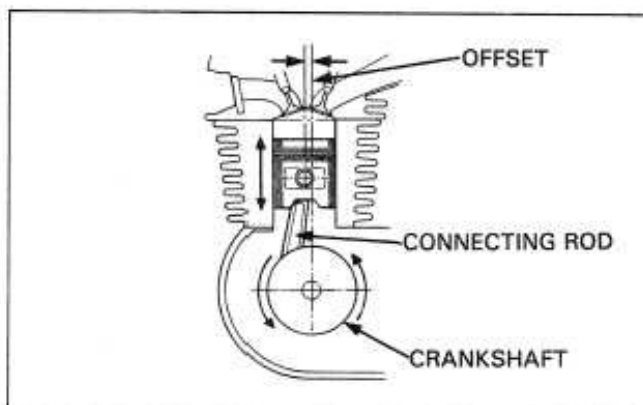
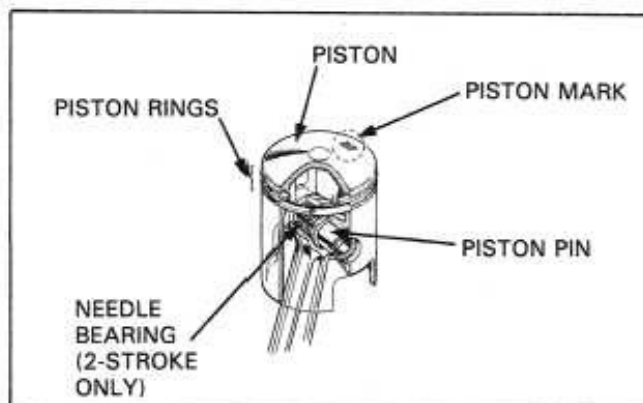

CYLINDER/PISTON

The oil ring is needed to remove oil from the cylinder wall and return the residue from the hole of the oil ring groove. If the oil ring fails, oil flows into the combustion chamber and burns, causing smoke. The oil ring is either of a split type arranged with two side rails and a slotted expander, or an integral type with a slotted square edge.

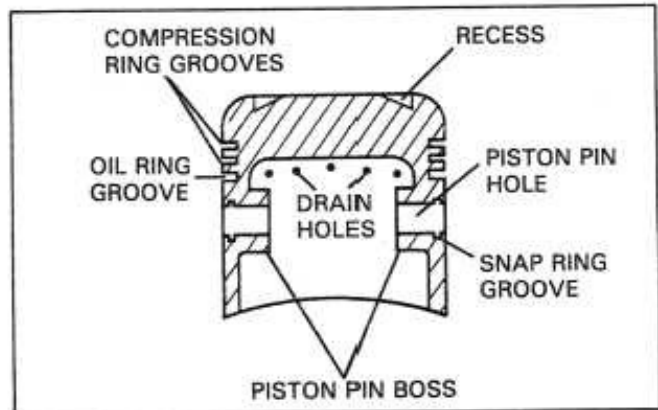
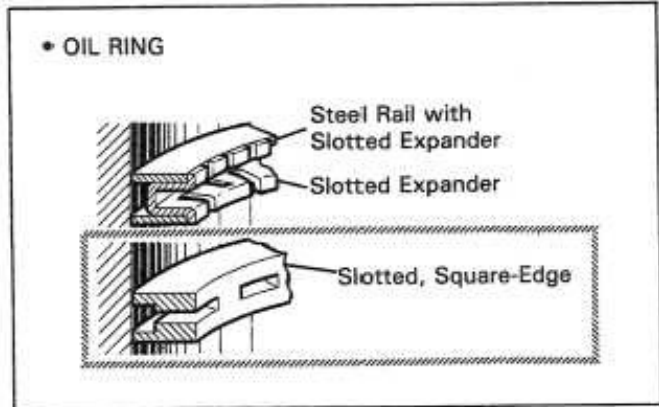

2-STROKE

As the 2-stroke engine has a different lubrication system, it is arranged with only the top and second rings and without an oil ring. As the 2-stroke engine has a cylinder wall with a port, a piston ring dowel is added to the ring groove of the piston, to prevent the rings from moving and hooking an edge in a port, causing breakage. The piston rings of the 2-stroke engine must therefore be assembled by aligning the end gaps to the dowels.

The design and shape of piston rings for 2-stroke engines are different than that of 4-stroke engines. A taper is provided over the entire cross section in 2-stroke ring design. This is because with the 2-stroke engine burning engine oil, carbon tends to adhere to the ring groove. If not remedied, the ring sticks to the groove, causing it to lose tension and resulting in decreased compression. The ring and the ring groove therefore have a tapered form to remove the carbon in the ring groove when the ring is compressed during engine movement. The rings of this type are called keystone rings.

Some 2-stroke piston rings are provided with an expansion ring inserted between the inside of the second ring and the piston. The tension of the expansion ring absorbs the impact generated when the piston contacts the cylinder wall, with a resultant decrease in engine noise.

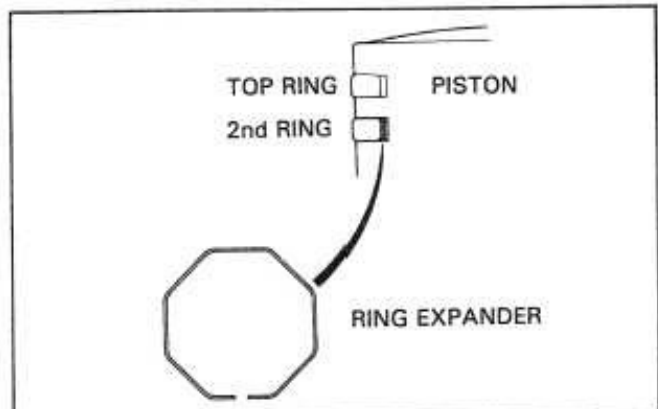
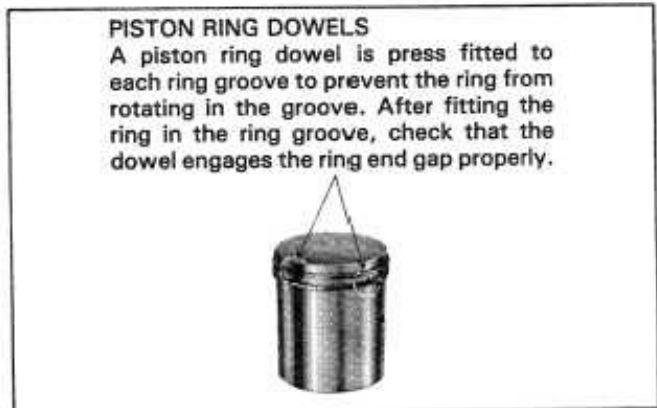

CYLINDER

WARPAGE INSPECTION

Remove the cylinder (see the Model Specific manual).

Carefully remove any adhering gasket material from the cylinder/head mating surface. Do not scratch the surface.

Check the cylinder for warpage by placing a straight edge and a feeler gauge across the stud holes. Replace the cylinder if the service limit is exceeded.

NOTE

- Any clearance between the cylinder and head due to damage or warpage will result in compression leaks and reduced performance.

WEAR INSPECTION

Inspect the cylinder wall for scratches and wear.

NOTE

- Inspect the area near T.D.C. (Top Dead Center) carefully. This area is especially subject to wear due to the possibility of borderline lubrication from heat and top ring compression.

Measure and record the cylinder I.D. at three levels in both an X and Y axis.

Take the maximum reading to determine the cylinder wear.

NOTE

- Two-stroke engines: avoid the intake and exhaust ports when measuring.

Measure the piston O.D. (see page 10-7).

Calculate the piston-to-cylinder clearance. Take the maximum reading to determine the clearance.

Calculate the cylinder for taper at three levels in an X and Y axis. Take the maximum reading to determine the taper.

Calculate the cylinder for out-of-round at three levels in an X and Y axis. Take the maximum reading to determine the out-of-round.

If any of the cylinder measurements exceed the service limits and oversized pistons are available, rebore to next smallest size possible and install the proper pistons. Otherwise, replace the cylinder.

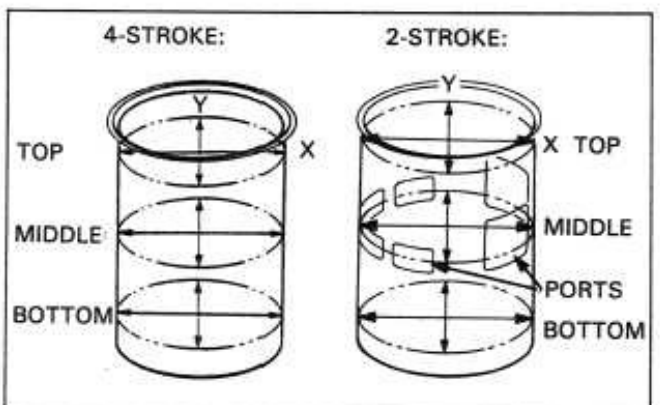
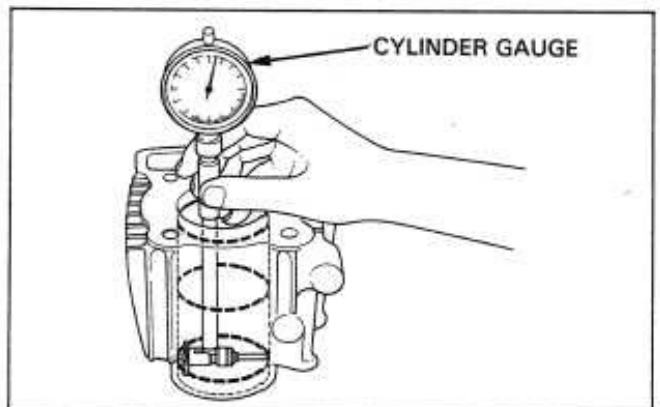
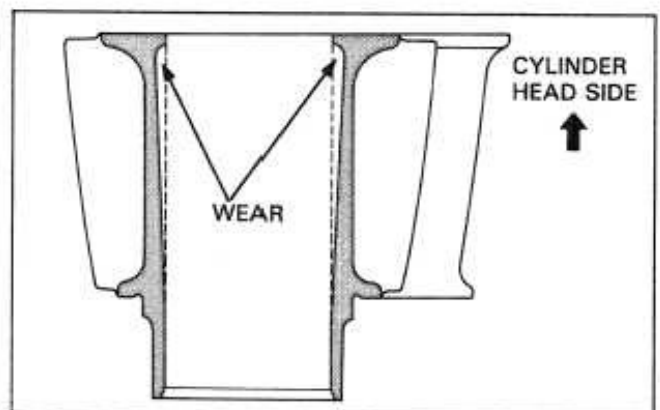
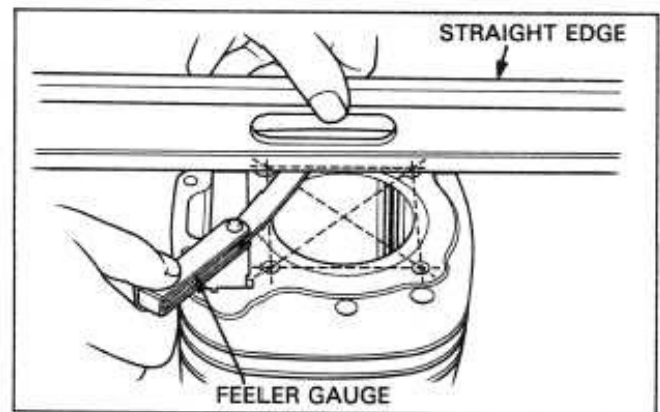

PISTON/PISTON RING

REMOVAL

NOTE

- Place a clean shop towel over the crankcase to prevent the possibility of the clip falling into the crankcase.

Remove the piston pin clip using a pair of pliers. Press the piston pin out of the piston.

2-stroke engines:

Remove the needle bearing from the small end of the connecting rod.

NOTE

- Do not damage or scratch the piston.
- Do not apply side force to the connecting rod.
- Do not let the clip fall into the crankcase.
- Mark and store the pistons and piston pins so that they can be reinstalled in their original positions.

INSPECTION

Clean carbon deposits from the piston.

NOTE

- Clean carbon deposits from the piston ring grooves with a ring that will be discarded. Never use the wire brush; it will scratch the groove.

Inspect the piston rings for movement by pressing the rings. The rings should be able to move in its groove without catching.

Spread each piston ring and remove it by lifting it up at a point just opposite the gap.

CAUTION

- Do not damage the piston ring by spreading the ends too far.

Some 2-stroke engines: Remove the expander from the second ring groove.

Inspect the piston:

- Sliding surface for scratches or wear. Remove any small surface scratches using #600–#800 sandpaper. If there are deep scratches, replace the piston.
- Piston ring grooves—for excessive wear. Replace the piston as necessary.
- 4-stroke engines: Oil pass holes in the oil ring groove—for clogs. Clean the oil holes with compressed air.

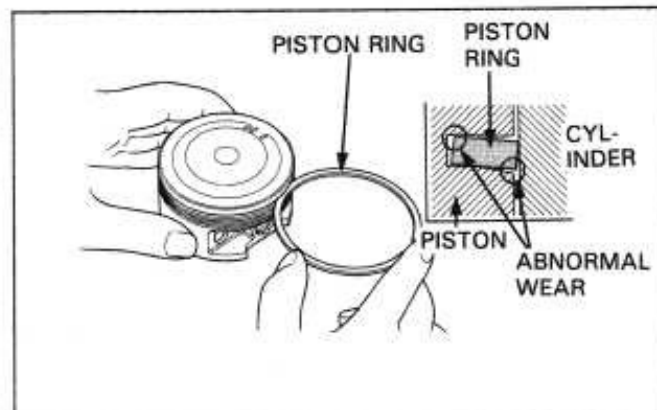
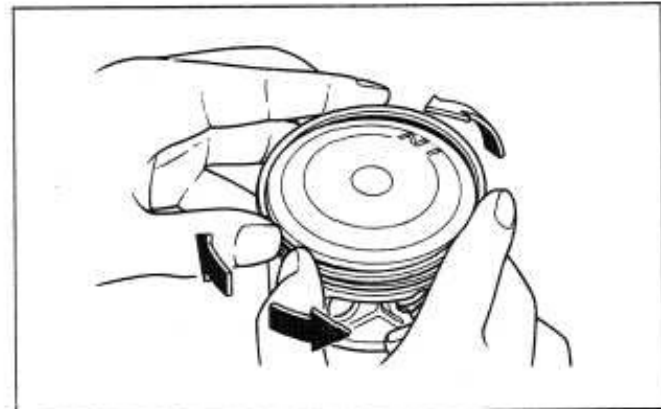
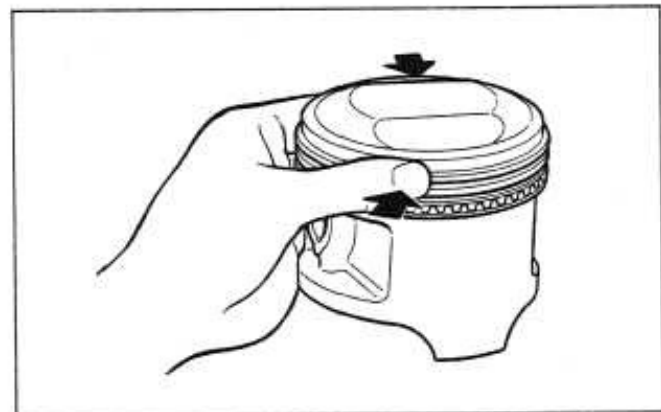
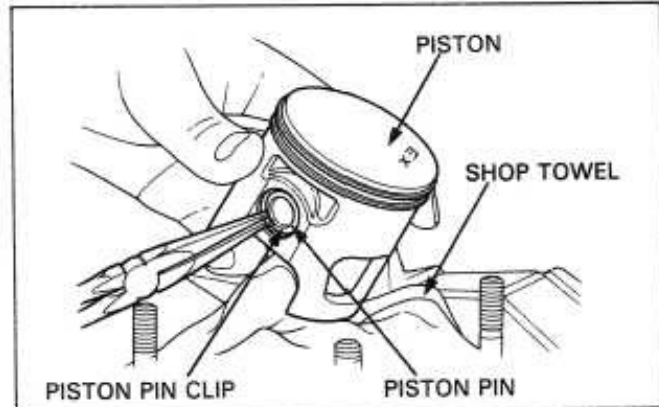

Measure and record the piston O.D. 90° to the piston pin bore and at the point specified in the Model Specific manual, near the bottom of the piston skirt.

Replace the piston if the service limit is exceeded.

Calculate the piston-to-cylinder clearance (see page 10-5).

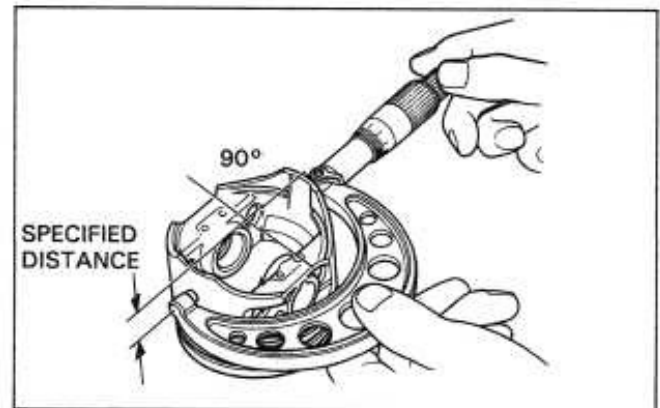

Measure the piston pin bore I.D. in an X and Y axis. Take the maximum reading to determine the I.D.

Replace the piston if the I.D. is over the service limit.

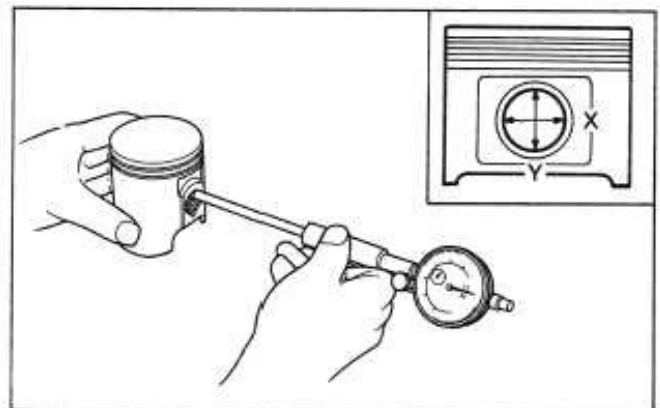

Inspect the piston rings, and replace them if they are worn.

NOTE

- Always replace piston rings as a set.

Reinstall the piston rings (see page 10-8) into the piston grooves.

Push in the ring until the outer surface of the piston ring is nearly flush with the piston and measure the clearance using a feeler gauge. Replace the piston ring if the service limit is exceeded.

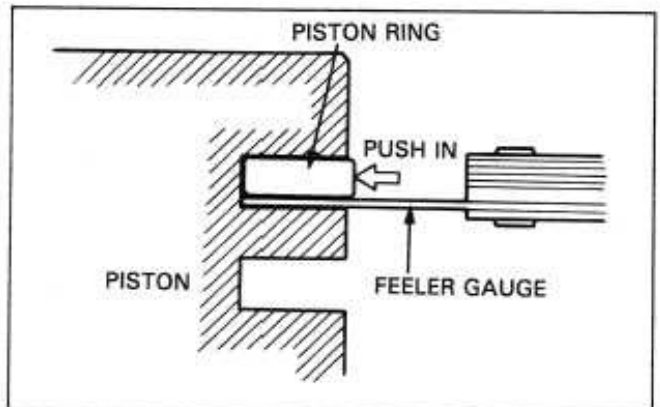

Insert the piston ring into the bottom of the cylinder squarely, using the piston as shown.

Measure the end gap using a feeler gauge. Replace the ring if the service limit is exceeded.

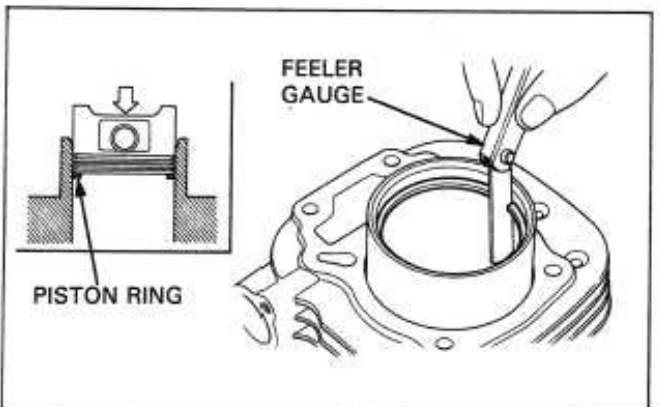

CYLINDER/PISTON

PISTON PIN INSPECTION

Measure the piston pin O.D. at three points.

Replace the piston pin if the service limit is exceeded.

Calculate the piston pin-to-pin bore clearance by subtracting the piston pin O.D. from the pin bore I.D.

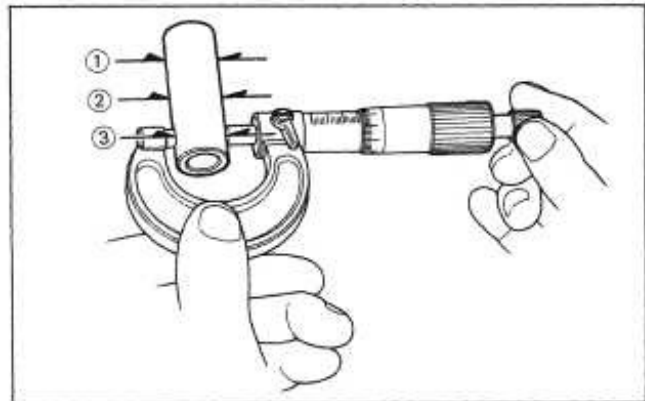

SMALL END BEARING SURFACE INSPECTION

2-stroke Engines:

Install the needle bearing and piston pin in the connecting rod small end and check for excessive play.

If the piston pin I.D. is over the service limit, the crankshaft must be replaced. Measure the I.D. of the connecting rod small end.

4-stroke Engines:

Measure the I.D. of the connecting rod small end.

Replace the connecting rod or crankshaft assembly if the service limit is exceeded.

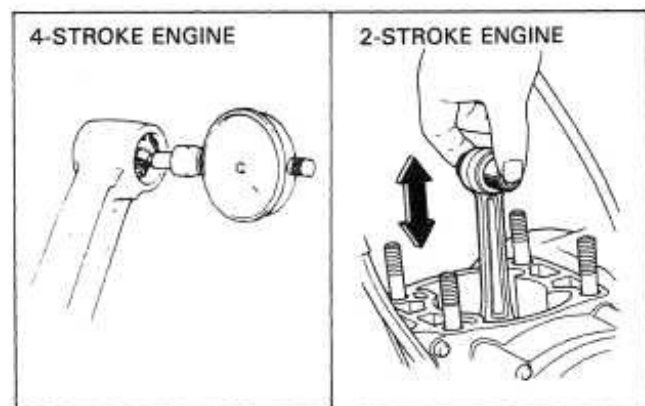

PISTON/PISTON RING INSTALLATION

4-stroke Engines:

Clean the piston heads, ring lands and skirts.

Carefully install the piston rings onto the piston with the markings facing up.

NOTE

- Be careful not to damage the piston and rings during assembly.
- Do not confuse the top and second rings: The top ring is chrome-coated and the second ring is not coated (black).
- After installing the rings they should rotate freely, without sticking.
- Space the ring end gaps 120 degrees apart.
- Space the side rail gaps 40 mm (1.6 in) or more apart as shown.

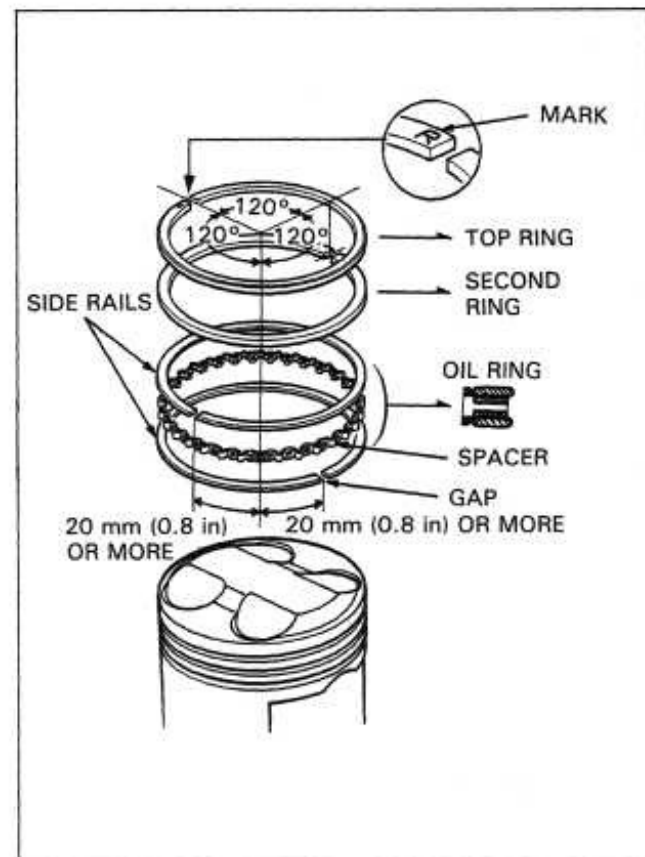

2-stroke Engines:

Clean the piston ring grooves.

Lubricate the piston rings and ring grooves with clean 2-stroke oil.

Install the piston rings on the piston with the marks facing up.

NOTE

- Do not confuse the top and second rings. Be sure to install them in the proper grooves.
- Some 2-stroke engines use an expander ring behind the second ring.

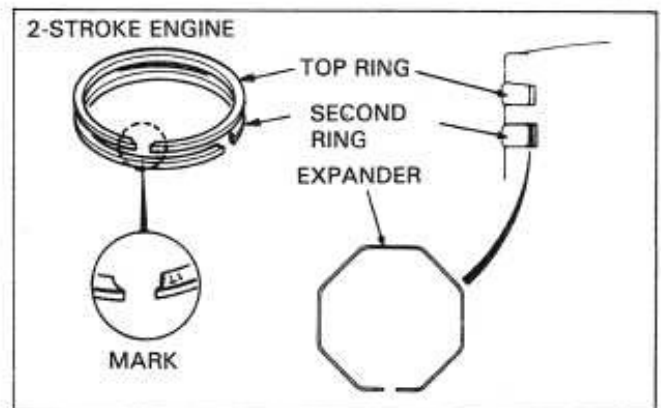

In 2-stroke engines, the piston has locating pins that hold the piston rings away from the intake and exhaust ports.

Align the piston ring end gaps with the locating pins.

Check the fit of each ring in its groove by pressing the ring into the groove. Make sure that it is flush with the piston at several points around the ring.

If the ring rides on the locating pin, it is damaged during assembly.

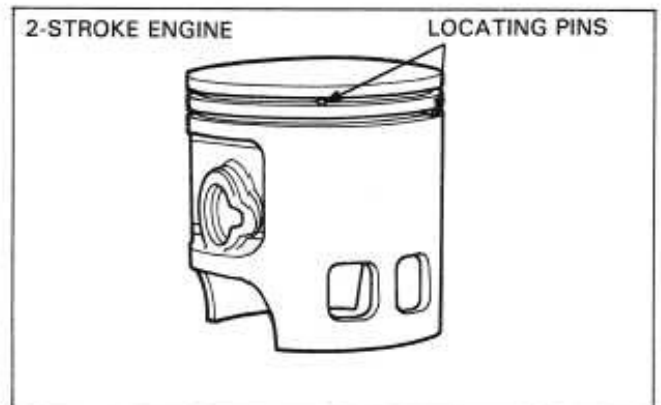

PISTON INSTALLATION

Coat the needle bearing (2-stroke engine only) and piston pin with the recommended oil.

Lubricate the piston pin.

4-STROKE ENGINE: Molybdenum solution

2-STROKE ENGINE: Recommended engine oil

NOTE

- Place a clean shop towel over the crankcase to prevent the clip from falling into the crankcase.

Install the needle bearing into the connecting rod.

Install the piston and insert the piston pin.

NOTE

- The mark that is stamped on the piston head should be facing the correct direction.
 "IN" MARK: TO INTAKE SIDE
 "EX" or "Δ" MARK: TO EXHAUST SIDE

Install new piston pin clips.

CAUTION

- Always use new piston pin clips. Reinstalling used piston pin clips may lead to serious engine damage.

NOTE

- Take care not to drop the piston pin clip into the crankcase.
- Set the piston pin clip in the groove properly.
- Do not align the clip's end gap with the piston cutout.

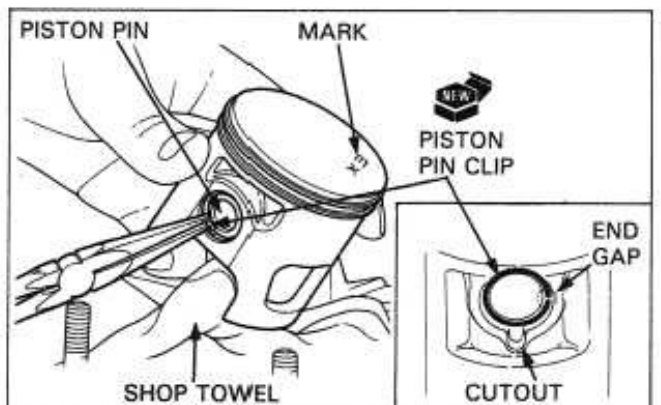
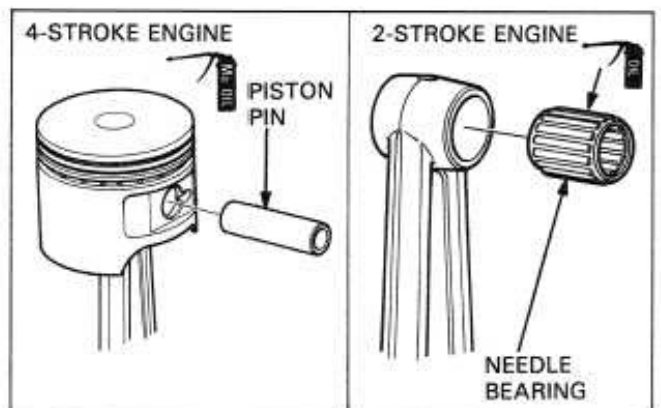

CYLINDER/PISTON

CYLINDER INSTALLATION

Make sure that the piston ring end gap is correct.
Install a new cylinder gasket and dowel pins.

Coat the cylinder wall with clean engine oil and install the cylinder.

NOTE

- Route the cam chain through the cylinder.
- Be careful not to damage the piston rings.

Single cylinder:

Install the cylinder over the piston while compressing the piston rings by hand.

Multi cylinder:

Position the piston at T.D.C. and install two piston bases to hold the 2/3 pistons.

Compress the rings with the piston ring compressor and install the cylinder.

Parallel four cylinders:

First install #2/3, then #1/4.

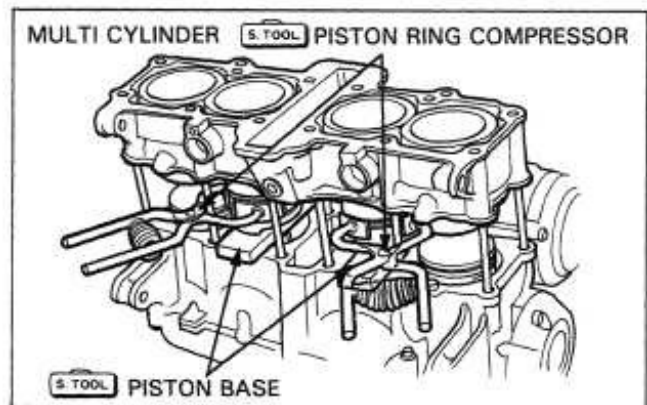
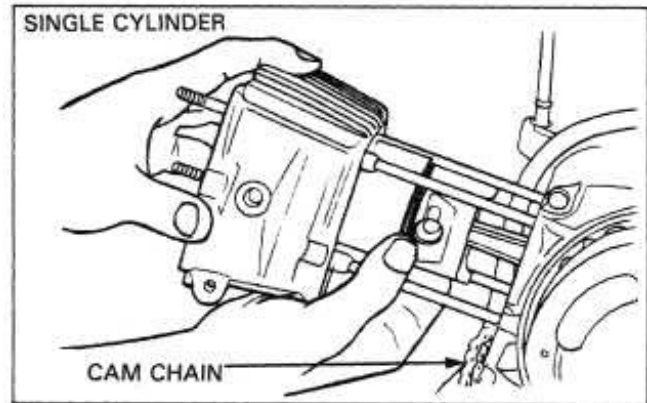

11. CLUTCH

SERVICE INFORMATION	11-1	CLUTCH INSPECTION	11-10
TROUBLESHOOTING	11-1	HYDRAULIC CLUTCH SYSTEM	
SYSTEM DESCRIPTIONS	11-2	SERVICE	11-27

SERVICE INFORMATION

- Clutch maintenance can be done with the engine in the frame.
- Refer to the Model Specific manual for removal/installation of the crankcase cover and specific clutch maintenance.
- Engine oil viscosity and level have an effect on clutch disengagement. When the clutch does not disengage or the vehicle creeps with clutch disengaged, inspect the engine oil level before servicing the clutch system.
- On wet centrifugal clutches, the clutch will not engage properly if the engine oil contains additives such as molybdenum disulfide. Oils with a molybdenum disulfide additive tend to reduce clutch friction.

TROUBLESHOOTING

11

Clutch lever too high

- Damaged, kinked or dirty clutch cable
- Damaged clutch lifter mechanism
- Faulty clutch lifter plate bearing
- Sticking clutch slave cylinder piston
- Clogged hydraulic system

Clutch will not disengage or motorcycle creeps with clutch disengaged

- Too much clutch lever free play
- Warped plate
- Loose clutch lock nut
- Oil level too high, improper oil viscosity or oil additive used
- Air in hydraulic system
- Low fluid level
- Hydraulic system leaking or clogged

Clutch slips

- Clutch lifter sticking
- Worn clutch discs
- Weak clutch springs
- No clutch lever free play
- Hydraulic system clogged

SYSTEM DESCRIPTIONS

The clutch system functions to disconnect/connect the power of the crankshaft. Most clutches are placed between the primary reduction and transmission. With some models, however, they are attached directly to the crankshaft. The actuation of the clutch can be roughly divided into two types: the manual clutch controlled by the rider and the centrifugal clutch which connects/disconnects power according to engine rotation.

The clutch controls the transmission of power by frictional force. When the clutch is completely disengaged, power cannot be transmitted to the rear wheel. When the vehicle is started, the clutch gradually increases its frictional force and smoothly transmits power to the rear wheel. When the clutch is completely engaged, the power of the crankshaft will be directly transmitted to the rear wheel.

If the clutch is partially released with the engine at high rpm, the reduction in friction force caused by heat or wear in the clutch causes the clutch to slip even when completely engaged. As a result, power transmission is lost.

WET MULTIPLATE MANUAL CLUTCH (TYPE A: OUTER PUSH TYPE)

This is the most conventional clutch type used on motorcycles. The primary drive gear of the crankshaft drive the primary driven gear integrated in the clutch outer. The clutch discs and the clutch outer rotate with the crankshaft, because the claws of the clutch disc are engaged with the grooves of the clutch outer.

The mainshaft of the transmission and the clutch center are fixed with a lock nut. Furthermore, the clutch center and the clutch plates are engaged with splines. Thus, the clutch plates rotate with the rear wheel through the transmission.

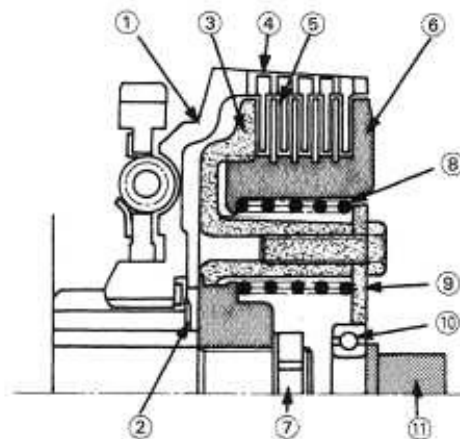
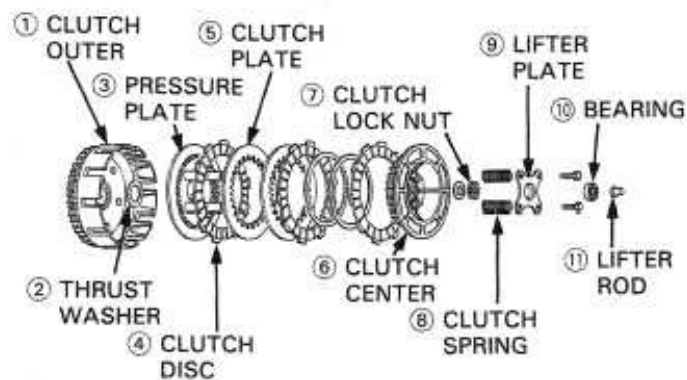

When the clutch lever is pulled in, the clutch lifter mechanism presses the pressure plate through the lifter plate, resulting in a gap between the discs and the plates. The power of the crankshaft is now not transferred to the rear wheel.

When operating the transmission gear and gradually releasing the clutch lever, the pressure plate begins to press the disc and plate by the tension of the spring, and the discs and the plates begin to transmit power by sliding contact. At this time, the vehicle will start to move.

When the clutch lever is completely released, the discs and plates are completely caught between the pressure plate and the clutch center, and no longer mutually slip. The power of the crankshaft is thus completely transmitted to the rear wheel.

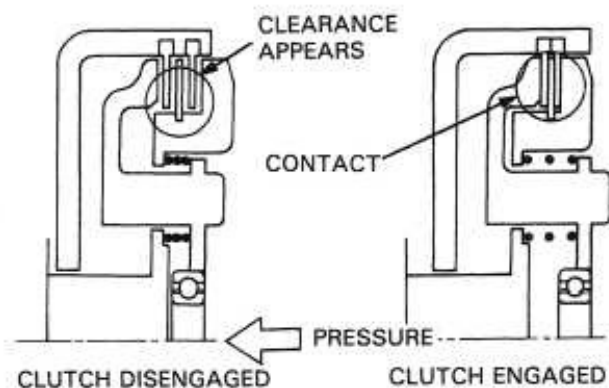

Judder Spring Purpose

When the clutch lever is released to engage the clutch, the clutch discs and plates sometimes engage intermittently causing judder or vibration to some degree.

To lessen this symptom, some models are equipped with a judder spring.

The clutch discs and plates are pressed by the judder spring tension and each disc and plate engages smoothly.

A judder spring is not installed on motorcycles on which the judder is not bothersome.

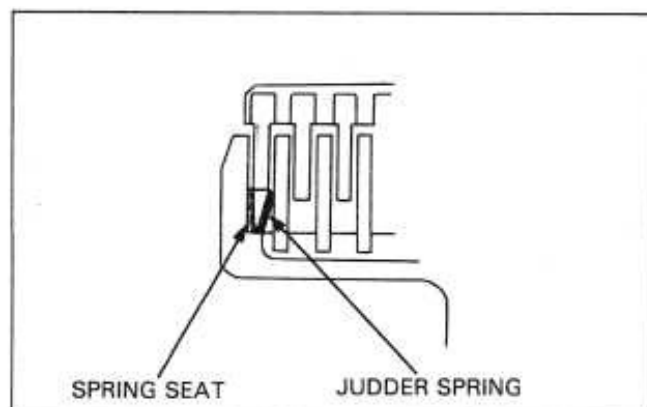

Damper Spring Purpose

When the engine is running, the combustion pressure that the piston receives is applied to the crankshaft intermittently and the clutch outer primary driven gear receives the striking force from every piston stroke.

Due to the pulsing nature of the power input, a damper spring is installed between the clutch outer and primary driven gear, close to the crankshaft.

The damper springs absorb the impact of the power pulses so they are not transmitted through the rest of the drive line. The drive train is thus protected from unnecessary damage and overall vibration is reduced.

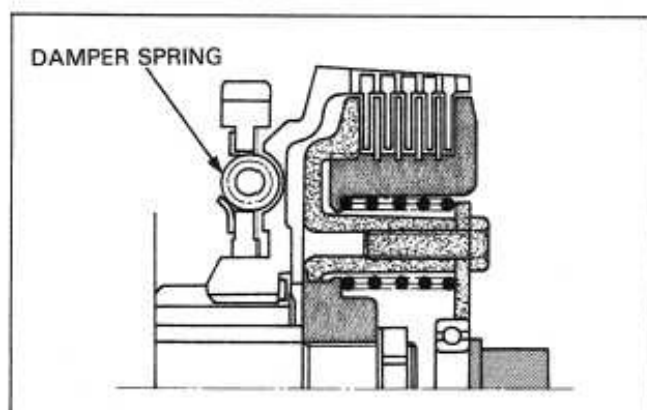

TYPE B (INNER PUSH TYPE)

The clutch lifter mechanism of this type is equipped on the opposite side of the clutch, and is different from the type A. The push rod is installed through the mainshaft and presses the clutch pressure plate located outside of the clutch outward to disengage the clutch. All but the above characteristic are the same as type A.

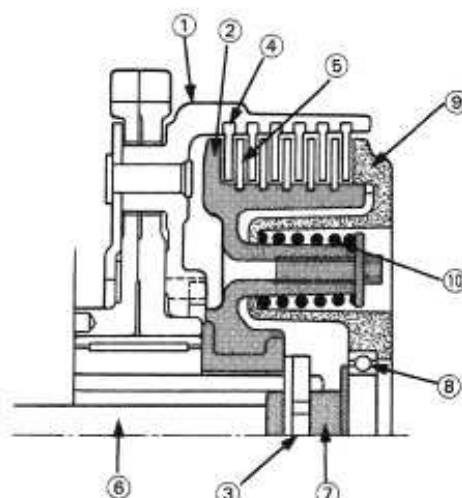
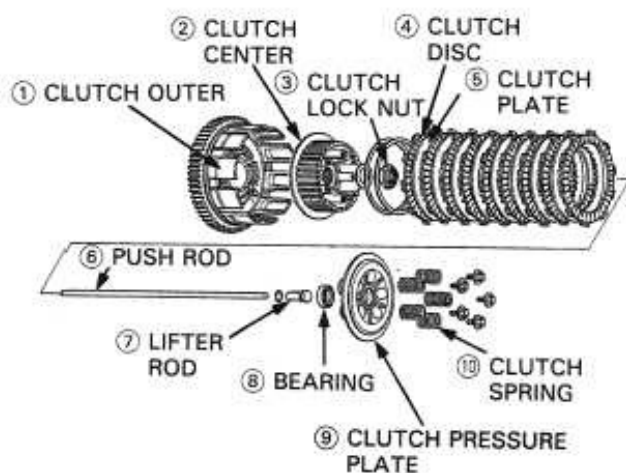

Power transmission and operating principle are the same as type A (see page 11-2).

CLUTCH

ONE-WAY CLUTCH SYSTEM (TYPE C: INNER PUSH TYPE WITH BACK TORQUE LIMITER MECHANISM)

On rapid downshifting from high RPM, the compression braking forces created by the engine can exceed the rear wheel's traction; the engine becomes a rear wheel brake. This can cause momentary lockup of the rear wheel — until the compression braking force drops below the level necessary to make the rear tire break traction. If multiple downshifts are made, the result will be a much longer loss of traction. The one-way clutch system has been specifically designed to prevent this loss of traction.

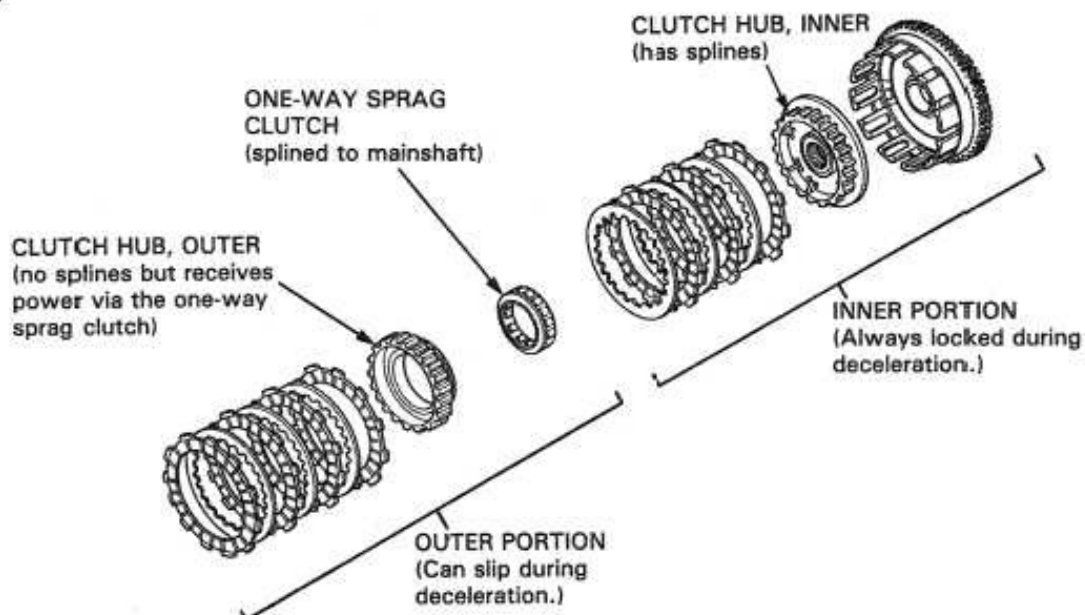

The major difference between this system and a conventional clutch is a two-piece clutch hub, inner and outer. In addition, the outer portion of the clutch hub, that which controls the majority of the clutch plates and discs, is driven by a special one-way sprag clutch.

The inner portion of the clutch hub is splined to the transmission's mainshaft as is normal. But it only controls about two-fifths of the clutch plates and discs. This portion of the clutch transmits power and deceleration forces in the usual manner.

The outer portion of the clutch hub is not splined to the transmission's mainshaft. It controls about three-fifths of the clutch plates and discs. This portion transmits power when the sprag clutch is locked up, such as during normal acceleration, cruising, and deceleration. But it will slip during high RPM deceleration.

OPERATION:

When the transmission is downshifted from high RPM, it causes a backloading at the clutch because of the forces generated by the engine's compression braking effect. If these forces approach that which will cause the rear wheel to lock up, the one-way clutch will disengage the outer portion and allow the inner portion to slip. It will do this to a degree that allows the rear wheel to maintain traction while maintaining the highest effect of engine braking. So rather than being a harsh ON or OFF mechanism, the one-way clutch determines the correct amount of slip for each situation, all the while maintaining maximum possible engine braking effect.

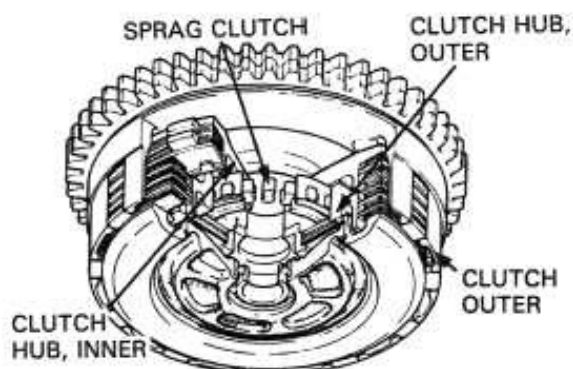

• **OPERATION**

During acceleration, cruising, and normal deceleration, power is transmitted through the clutch in the normal manner: Clutch outer → plate → disc → sprag clutch → mainshaft.

When there is a backloading on the clutch caused by the rear wheel nearing lock-up, the sprag clutch will slip just enough to prevent the wheel from locking without losing the benefit of maximum engine compression braking.

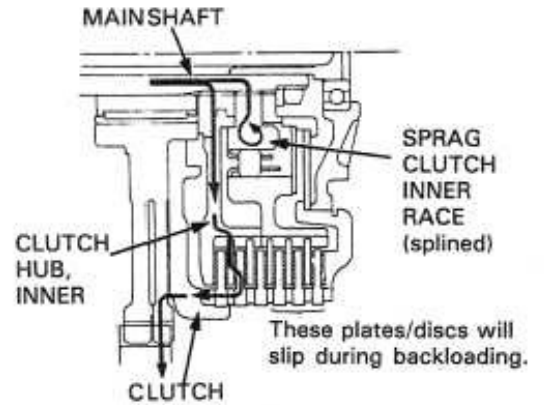
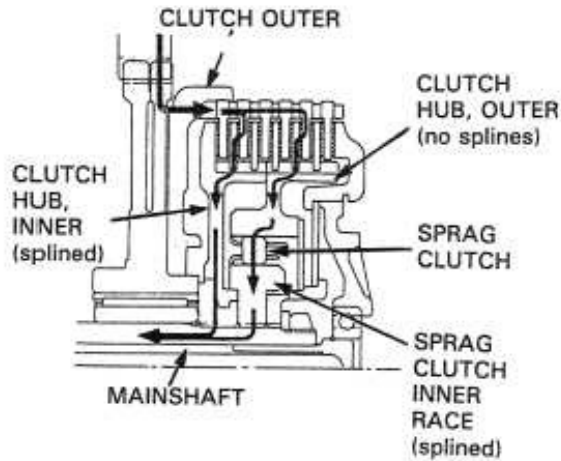

• **POWER FLOW DIAGRAM**

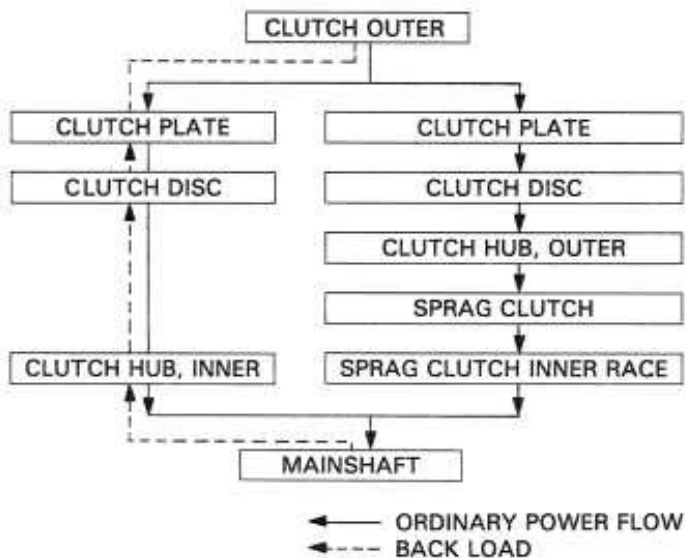

CLUTCH

TYPE D (CRANKSHAFT MOUNTED)

- Clutch outer is on the crankshaft

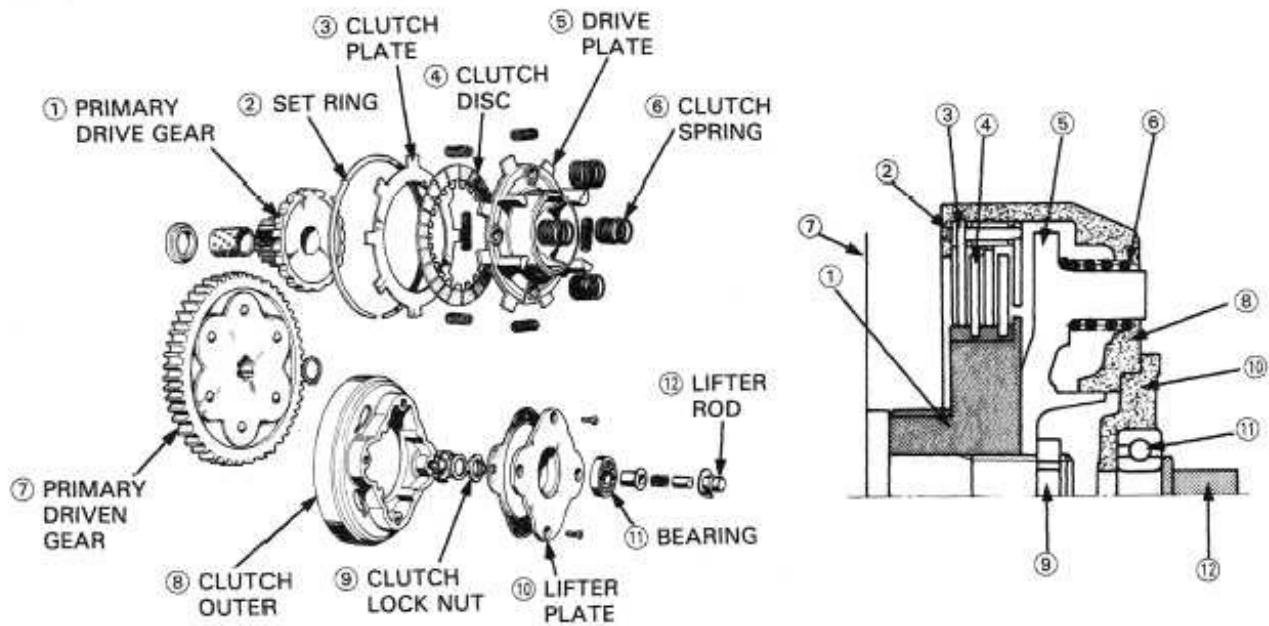

Power Flow Diagram

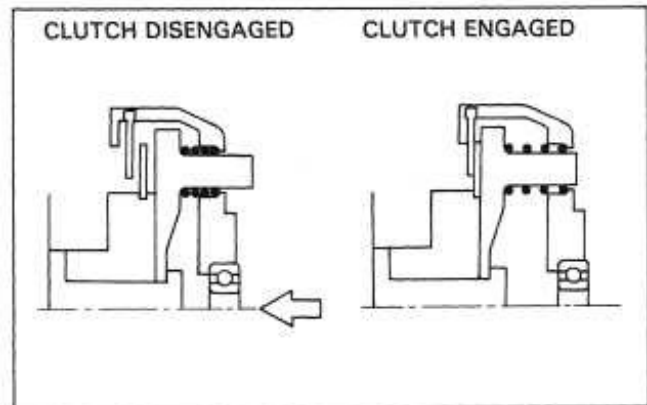
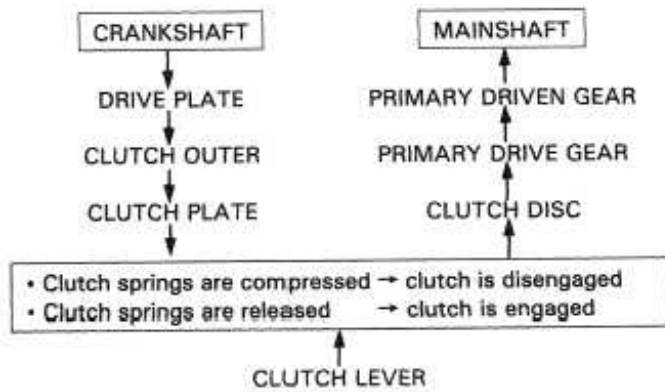

OPERATION:

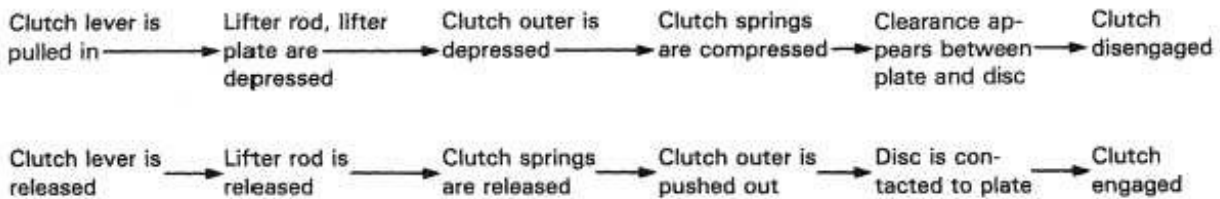

WET MULTIPLATE CENTRIFUGAL CLUTCH

The centrifugal clutch achieves a connection/disconnection of the clutch by the centrifugal force applied on the clutch rotated by the crankshaft. With this mechanism, the vehicle will not start when idling, because the centrifugal force is less and the clutch is disengaged. However, as the rotation of the engine increases, the clutch will be engaged and the vehicle can be moved without manual operation of the clutch.

When the centrifugal clutch is combined with the transmission, it will be provided with an independent mechanism, to disengage the clutch by the motion of the pedal when operating the gear shift. This is to disengage the clutch temporarily when changing gears, and to eliminate the pressure applied on the toothed surface of the gear transmission to enable the gear to slide smoothly, resulting in an easier shift.

TYPE A: SHIFT CLUTCH COMBINED

The centrifugal and shift clutches are combined to be mounted to the crankshaft.

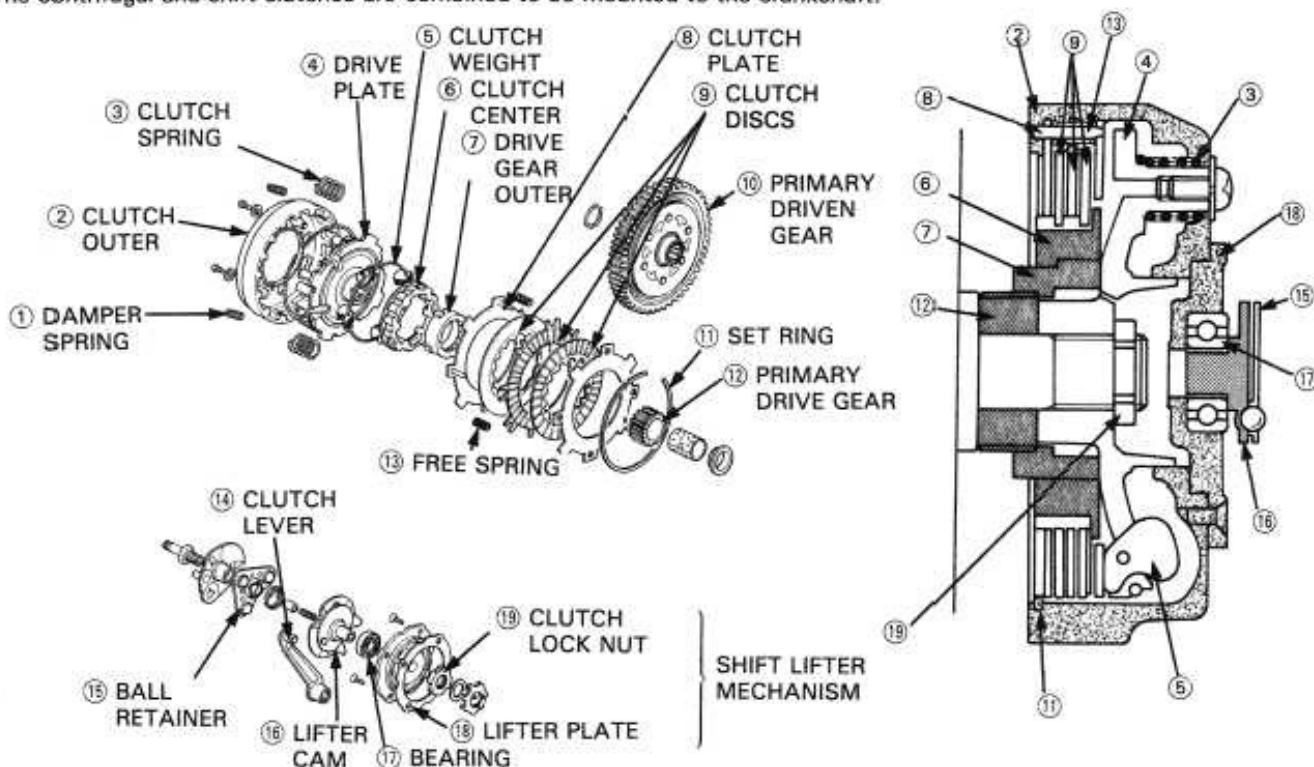

At low engine speeds, the centrifugal force applied on the clutch weight is less. The weight does not work, and a gap exists between the clutch plates and discs. The clutch is disengaged.

When the engine speed is increased, the centrifugal force applied to the clutch weight increases. The weight moves outwards and presses the clutch plate. The plates and the discs therefore press closely join and the power of the crankshaft will be transmitted to the primary drive gear.

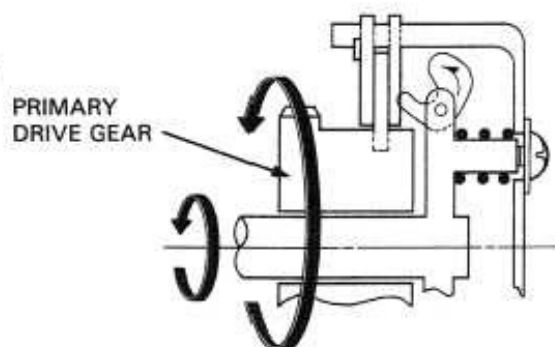
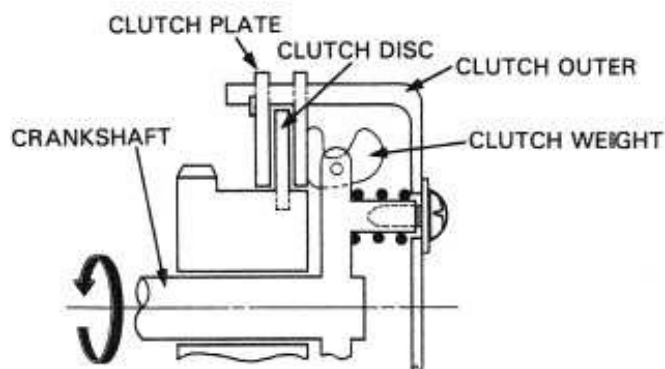

CLUTCH

In some cases, a roller is used instead of a clutch weight between the drive plate and the clutch plate. In this type, centrifugal force shifts the roller to the outside of the drive plate, causing the pressure on the clutch plate to engage the clutch.

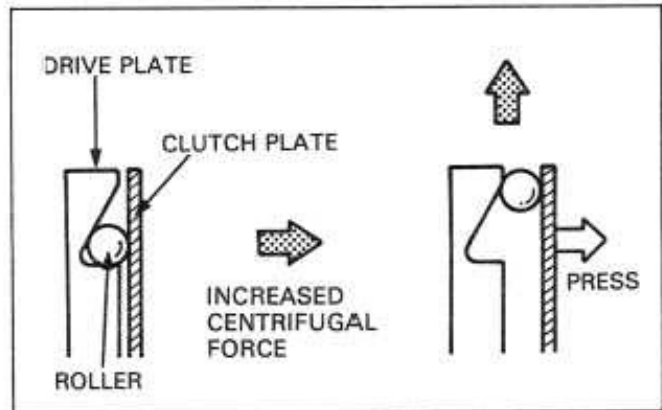

GEAR SHIFT LIFTER

When the shift pedal is operated, the rotation of the gear shift spindle rotates the lifter cam through the clutch lever. When the lifter cam is rotated, the ball positions of the ball retainer and the lifter cam are dislocated, causing the lifter cam to lift for the distance shown in the figure (a) and the pressure plate is pressed.

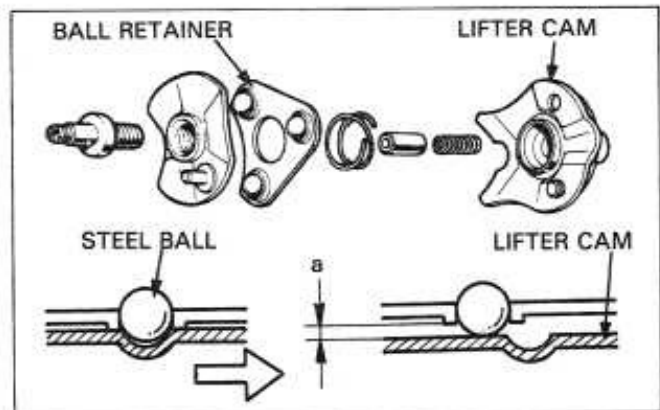

When the pressure plate is pressed, the clutch outer contracts the spring and the whole clutch outer is pushed inwards. At this time, even though the clutch weight is closely joined to the disc and plate, a gap will exist between the disc and plate from the motion of the clutch outer, and the clutch is then disengaged.

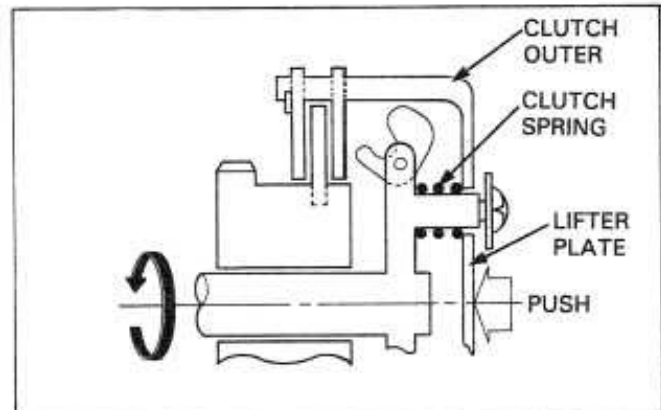

As the pedal is released after completion of shifting gears, the lifter cam returns to its original position. When the clutch outer returns to its original position by the tension of the clutch spring, the disc and the plate closely join again, and the clutch is then engaged.

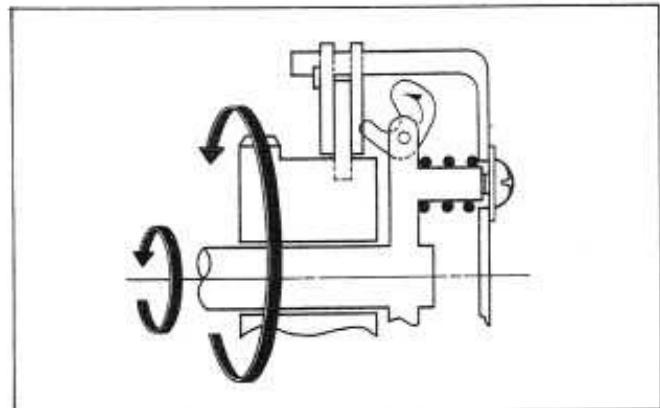

TYPE B: SEPARATED SHIFT CLUTCH

The centrifugal clutch and the shift clutch are separate in this type, increasing the clutch capacity in comparison with the combined type described on previous pages. Differing from the type mentioned in the previous section, the centrifugal clutch has a mechanism whereby the clutch shoe attached to the crankshaft is expanded outwards by centrifugal force, and the shoe is pressed against the inner surface of the clutch drum, allowing power transmission. This is a similar mechanism to a drum brake. The shift clutch is attached to the mainshaft as with a manual clutch. The work of engaging/disengaging is also the same as with the manual clutch. The gear shift lifter mechanism is the same as that of the combined type described in the previous section.

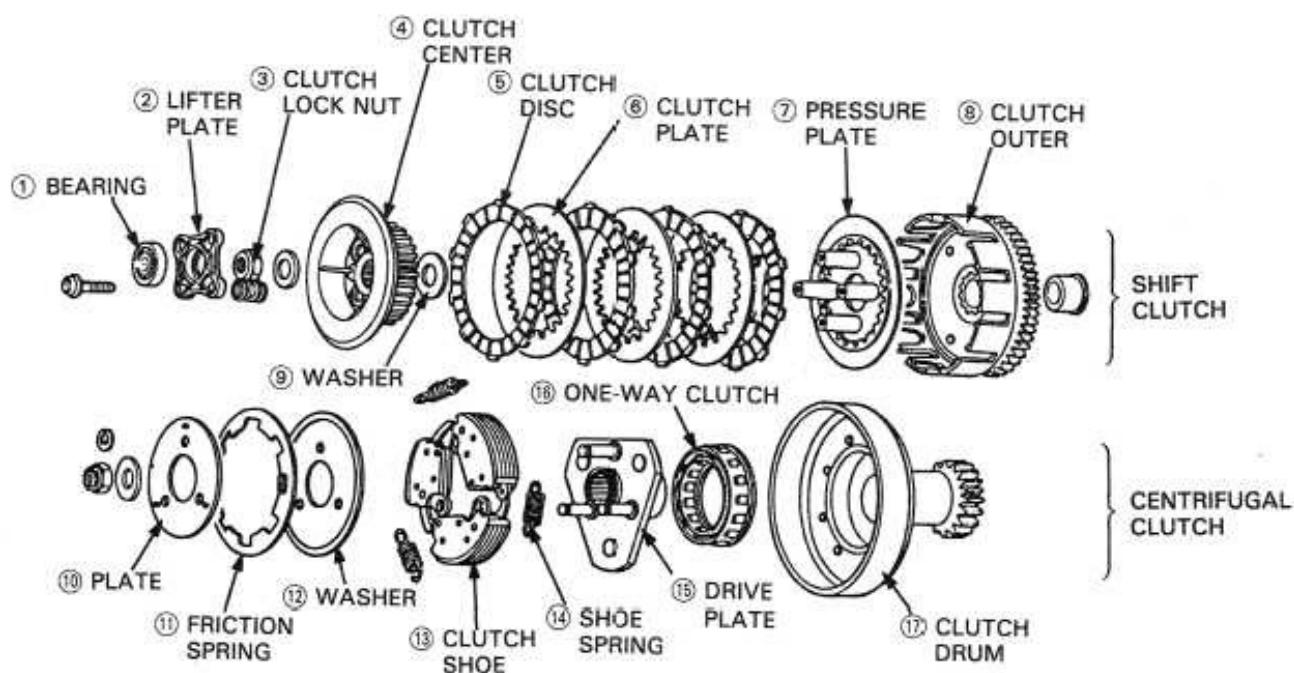

OPERATION PRINCIPALS

- Centrifugal operation: refer to belt automatic transmission.
- Lifter mechanism operation: refer to wet multiplate centrifugal clutch (Type A).
- Clutch mechanism operation: refer to wet multiplate centrifugal clutch (Type A).

CLUTCH

CLUTCH INSPECTION

CLUTCH LIFTER DISASSEMBLY/INSPECTION

(Type A and a part of Type B)

Remove the crankcase cover (Refer to Model Specific manual).

Remove the lifter rod and return spring.

If a spring pin is used, drive out the pin using a pin driver.

Remove the lifter shaft from the crankcase cover.

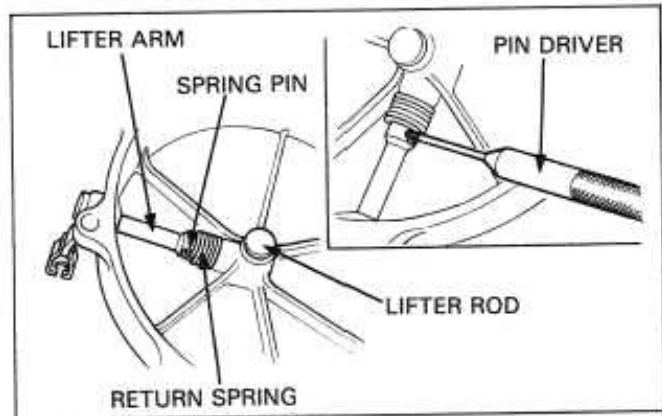

Check following:

- lifter rod for bending
- needle bearing for play or damage
- dust seal for damage
- return spring for damage or weakness

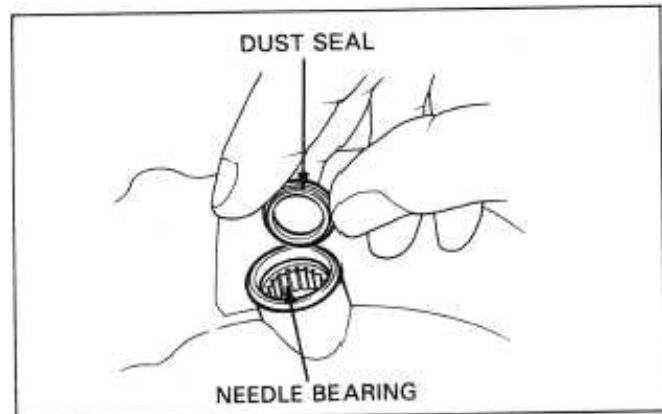

(Type D)

Remove the right crankcase cover (see the Model Specific manual).

Remove the screws and lifter cover.

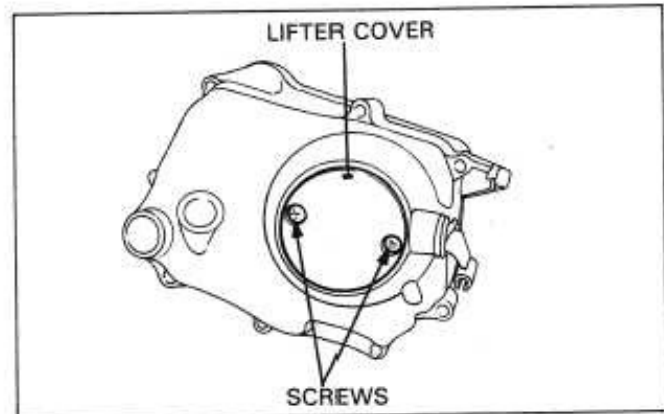

Remove the following:

- Stopper pin and lifter arm
- Screw and set plate
- Lifter plate and lifter rod

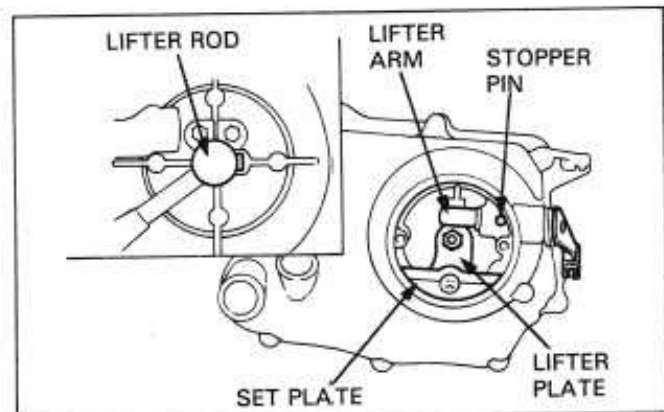

Check the following:

- Lifter arm, for straightness
- Return spring for weakness
- O-ring, for damage
- Sliding surface of the lifter arm, for abnormal wear or damage.

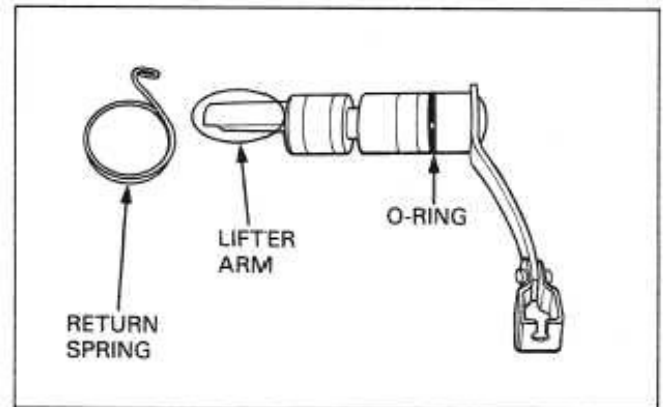

CLUTCH REMOVAL/DISASSEMBLY

(Type A)

Loosen the clutch spring bolts in a crisscross pattern in 2 or 3 steps.

Remove the clutch spring bolts, lifter plate and clutch springs.

If the clutch is secured with a staked lock nut, unstake the nut.

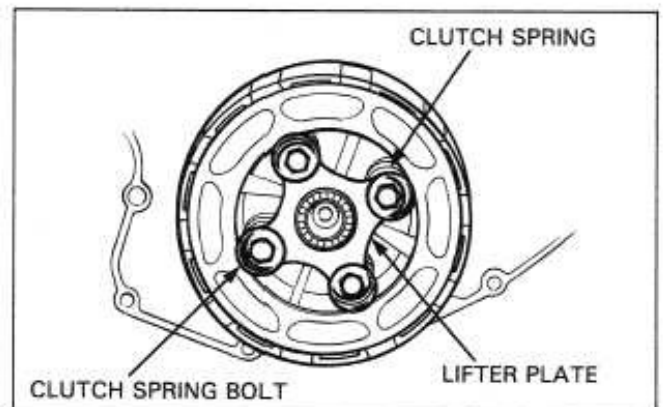

Remove the lock nut and lock washer using a special tool.

If a snap ring is used, remove the snap ring and clutch assembly.

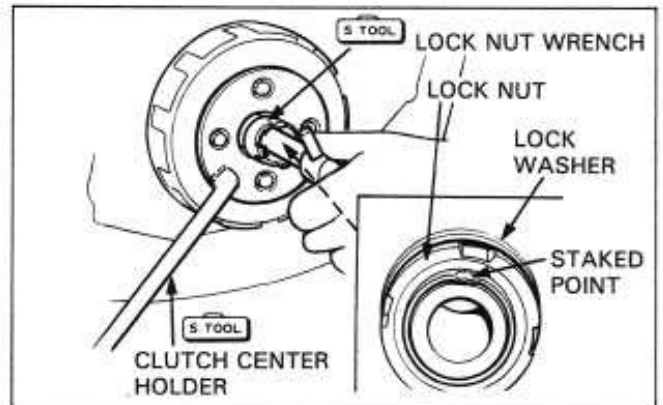

(Type B)

Loosen the clutch spring bolts in a crisscross pattern in 2 or 3 steps.

Remove the clutch spring bolts, pressure plate and clutch springs.

NOTE

- Hydraulic Clutches: To protect the clutch system from air contamination slowly squeeze the clutch lever immediately after removing the pressure plate, then tie the lever to the handlebar grip.

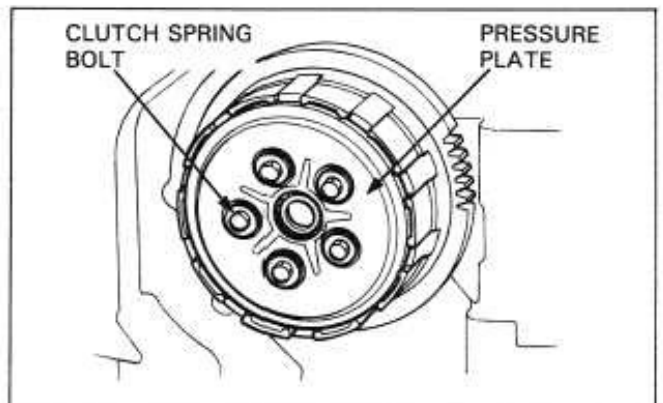

CLUTCH

Remove the lifter rod, push rod, discs and clutch plates.

NOTE

- Some models have a steel ball between the lifter and push rods.

Remove judder spring and spring seat if they are installed.

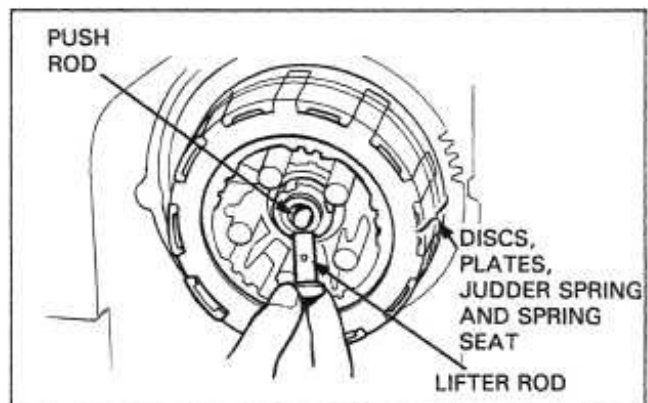

If the lock nut is staked to the mainshaft, unstake the lock nut and remove it.

Remove the lock washer.

Remove the clutch center and clutch outer.

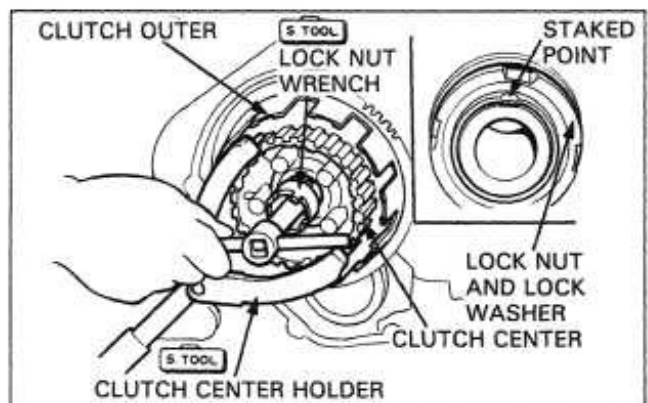

(Type C)

Remove the set ring, lifter plate, lifter rod and bearing.

Slowly squeeze the clutch lever immediately after removing the clutch lifter plate, then tie the lever to the handlebar.

CAUTION

- Ambient air can contaminate and may damage the clutch system.

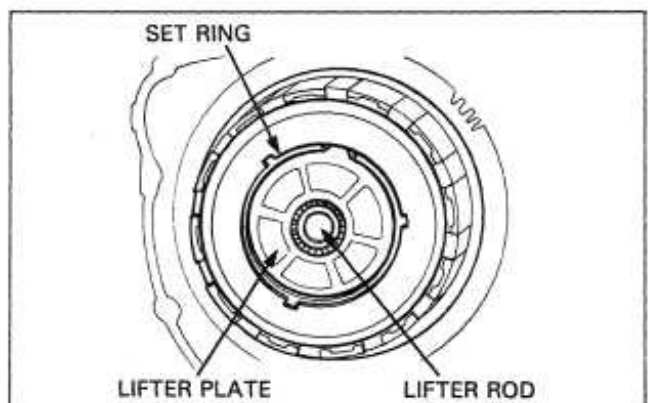

Shift the transmission into top gear and apply the rear brake. Remove the lock nut.

NOTE

- If the engine is not in the frame, shift the transmission into top gear and hold the drive sprocket using the universal holder (07725-0030000).

Remove the lock washer, clutch spring set plate, clutch spring and washers.

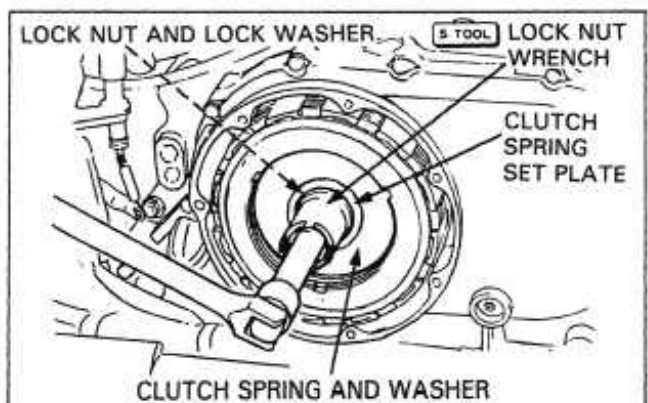

Remove the clutch pressure plate, clutch plates and discs.

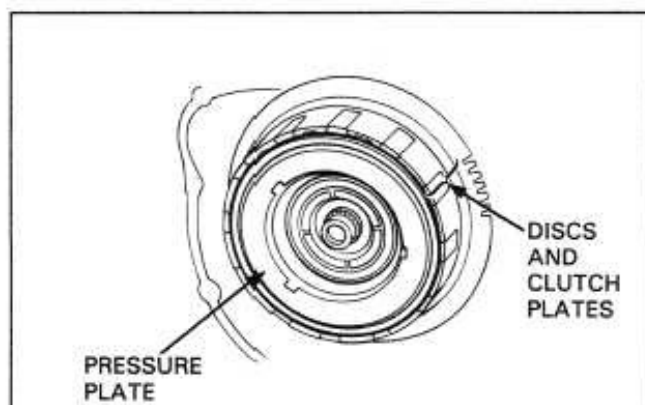

Remove clutch center B and the one-way clutch as an assembly.

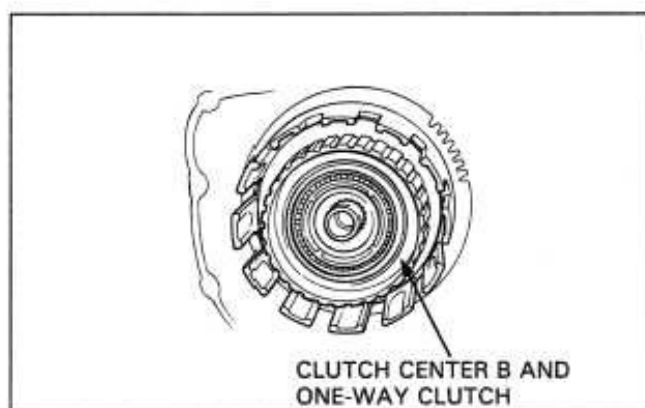

Remove clutch center A, the washer and the clutch outer.

Remove the clutch outer guide.

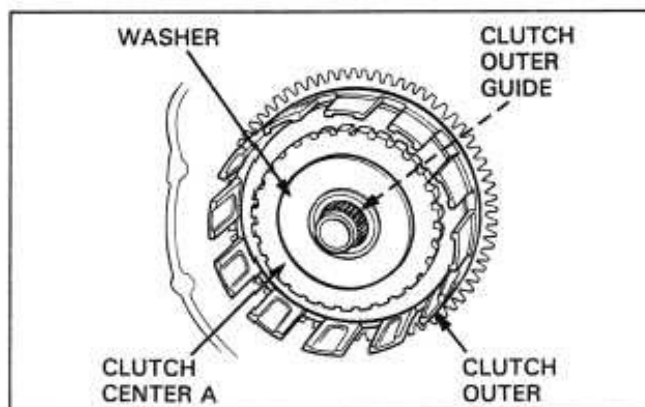

(Type D)

Remove the lifter, spring and oil through guide.

Remove the screws, clutch outer cover and gasket.

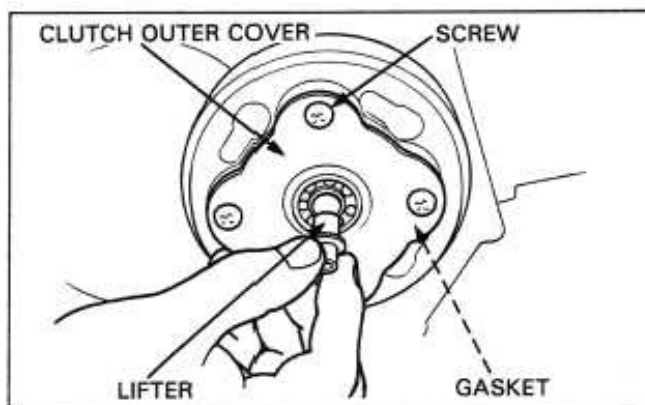

CLUTCH

Straighten the lock washer tab.

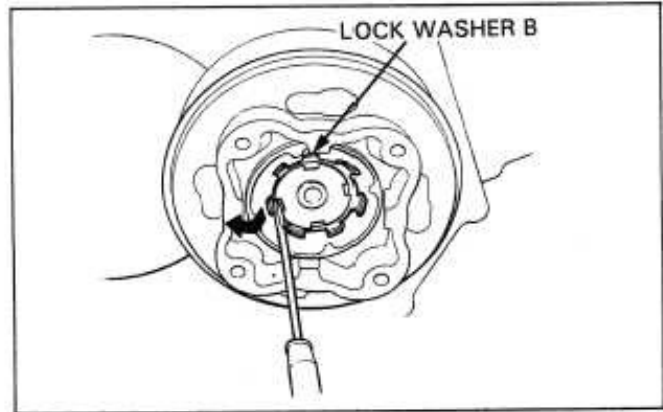

Hold the clutch outer using the clutch outer holder.

Remove the lock nut using the lock nut wrench.

Remove lock washers A and B; discard washer B.

NOTE

- Replace lock washer B whenever it is removed.

Remove the clutch assembly from the crankshaft.

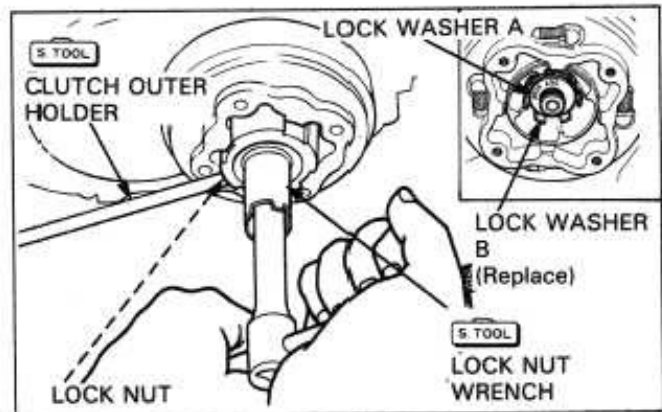

Remove the snap ring and primary driven gear from the mainshaft.

Remove the clutch center guide and collar from the crankshaft.

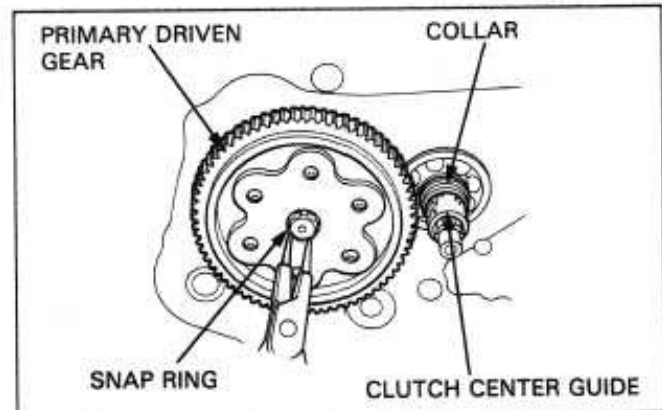

Remove the damper springs from the clutch outer.

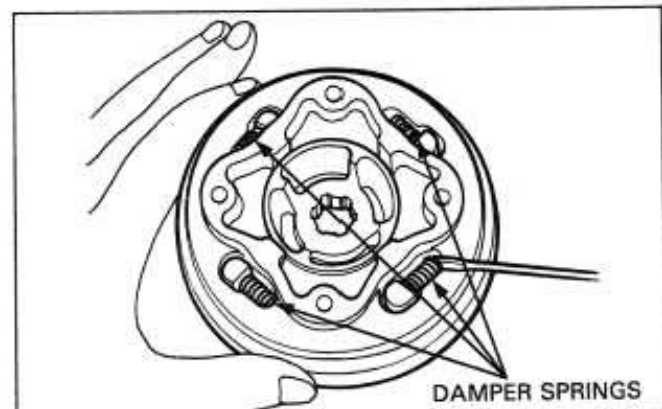

Install the primary drive gear onto the clutch assembly and compress the clutch springs using the clutch spring compressor, then remove the set ring.

S TOOL

CLUTCH SPRING COMPRESSOR 07960-0110000

Loosen and remove the tool, then disassemble the clutch.

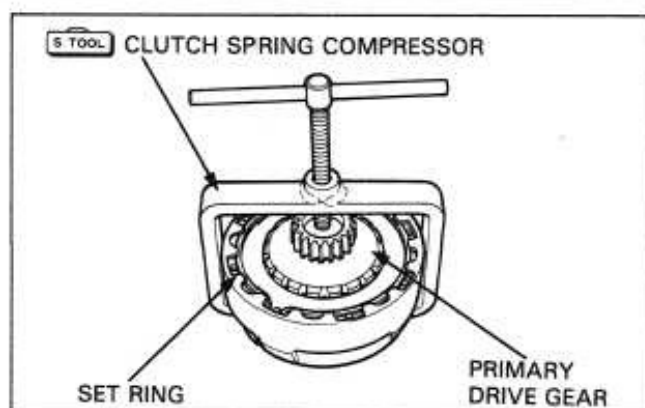

CLUTCH INSPECTION

Lifter Plate Bearing (Type A, B, C, and D)

The lifter plate bearing inner race is loaded by the lifter rod when the clutch is disengaged. Inner bearing race damage affects the clutch operation.

Turn the bearing inner race with your finger, and check that the bearing turns smoothly and quietly without play. Also check that the outer race fits tightly in the lifter plate.

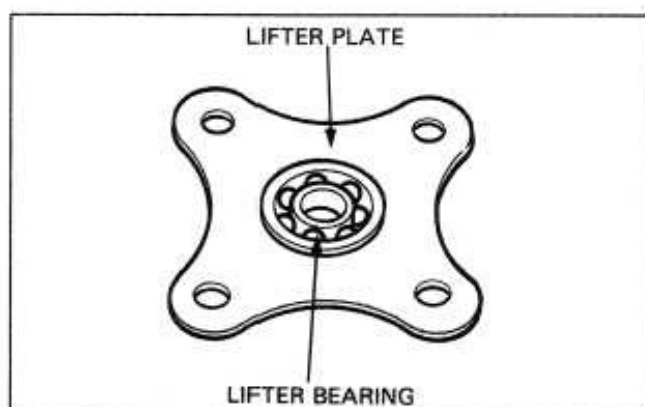

Clutch Outer (Types A, B, C and D)

- Check the primary driven gear teeth for wear or damage; replace as necessary.
- Check the slots of the clutch outer for nicks, damage or wear from the clutch discs; replace as necessary.

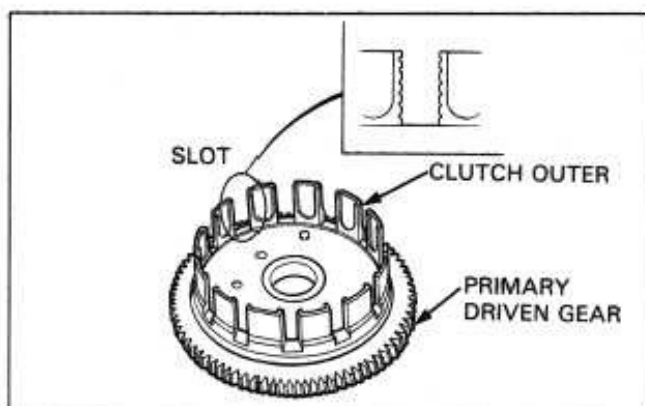

Clutch Outer Guide, Needle Bearing (Types A, B and C)

- Measure the I.D. and/or O.D. of the clutch outer guide. Replace if the service limits are exceeded.
- Check the needle bearing for damage or excessive wear; replace if necessary.

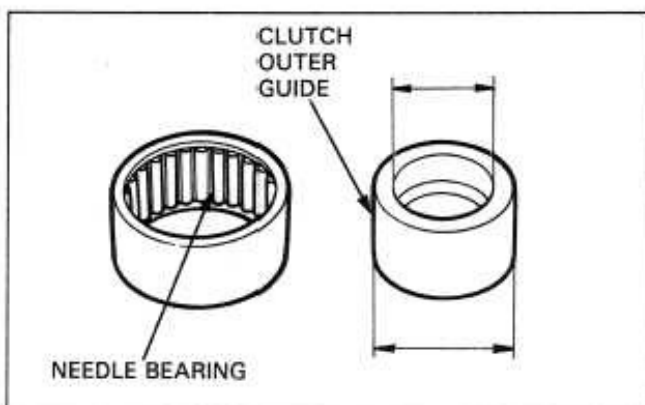

CLUTCH

Clutch Disc (Types A, B, C and D)

- Check the clutch discs for scoring or discoloration; replace as necessary.
- Measure the disc thickness and replace the discs if the service limit is exceeded.

NOTE

- Replace the clutch discs and plates as a set.

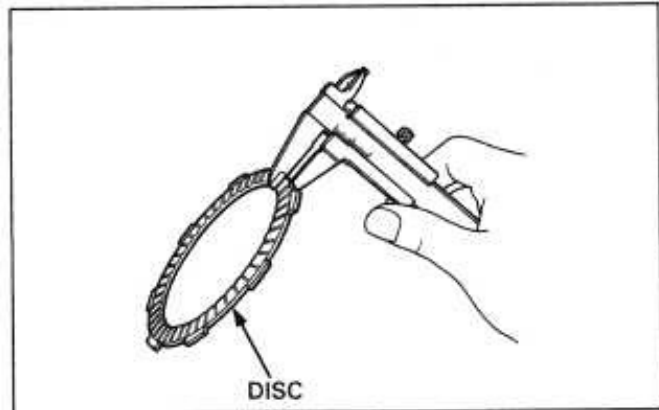

Clutch plate (Types A, B, C and D)

- Check the clutch plates for warpage or discoloration; replace if necessary.
- Check for plate warpage on a surface plate using a feeler gauge; replace if the service limit is exceeded.

NOTE

- Warped clutch plates prevent the clutch from disengaging properly.

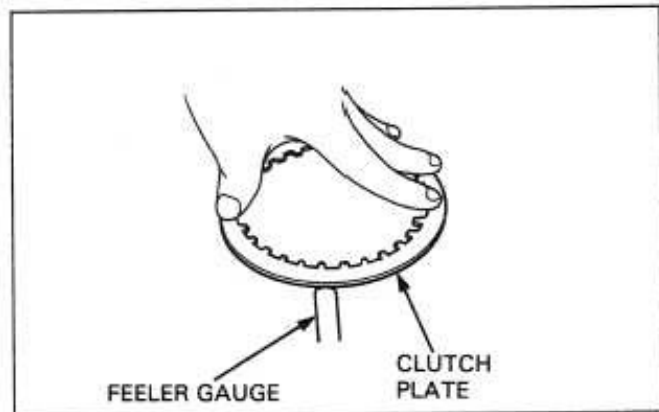

Clutch Center

Check the clutch center for nicks, grooves or abnormal wear from the clutch plates; replace as necessary.

NOTE

- A damaged clutch center causes engine noise.

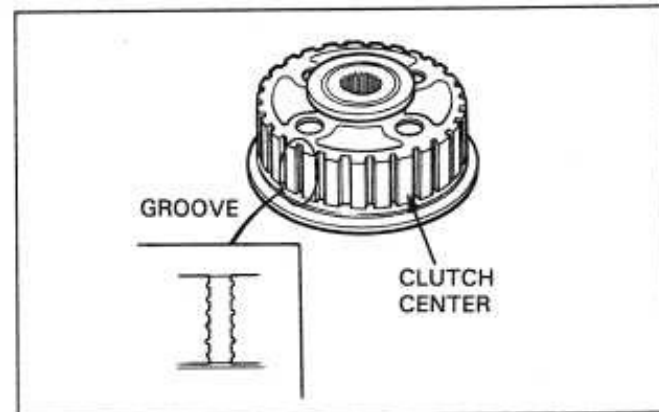

Lifter Push Rod (Types B and C)

Check the push rod for trueness or damage; replace if necessary.

If there is a steel ball between the lifter rod and push rod, check the ball for wear or damage; replace as necessary.

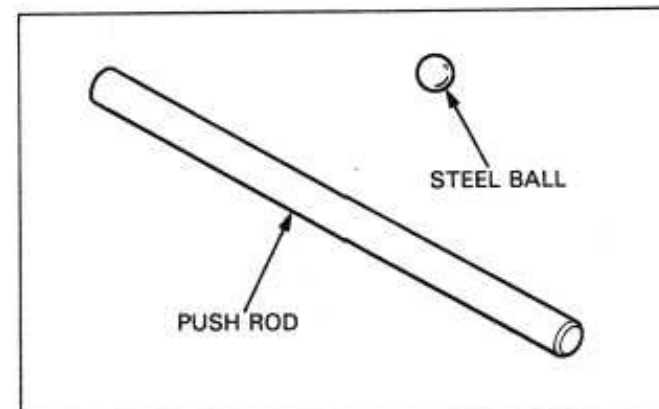

Judder Spring, Spring Seat**(Types A and B)**

Check the judder spring and spring seat for deformation, warpage or damage; replace as necessary.

A damaged or warped spring seat will cause the judder spring to be pressed unevenly.

A damaged judder spring also causes the weak contact between the discs and plates or uneven disc/plate contact.

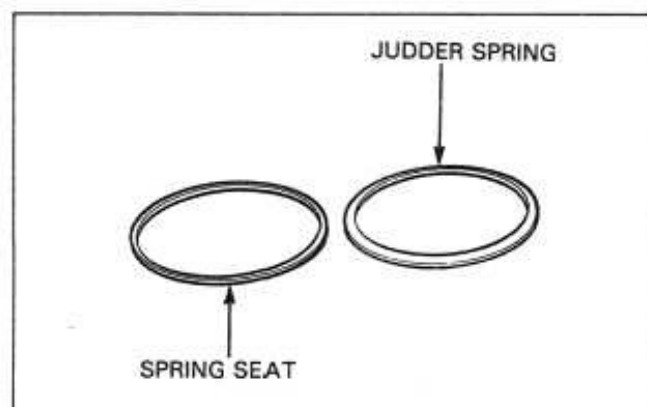
**Mainshaft****(Types A, B and C)**

Measure the mainshaft O.D. at the sliding surface, if the clutch outer guide slides on the mainshaft.

Replace the mainshaft if the service limit is exceeded.

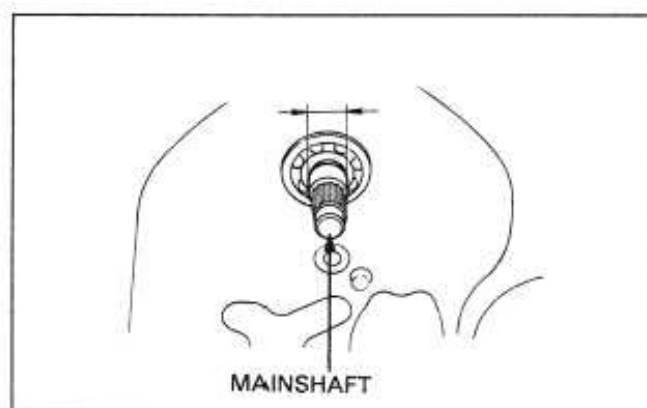
**Clutch Spring****(Types A, B and D)**

Measure the clutch spring free length; replace the springs if the measurement is not within the service limit.

NOTE

- If the vehicle has been used for a long time, the clutch spring free length will be shorter, because the clutch springs are compressed while the clutch is disengaged.
- Replace the clutch springs as a set so that the discs contact the clutch plates evenly.

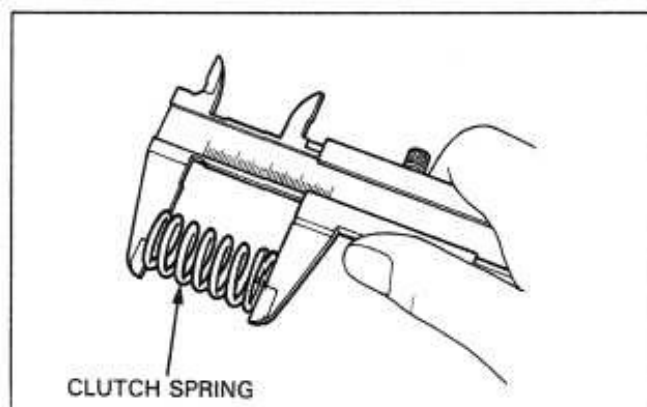
**Clutch Spring****(Type C)**

Measure the free height of the clutch spring; replace the spring if the measurement is lower than service limit.

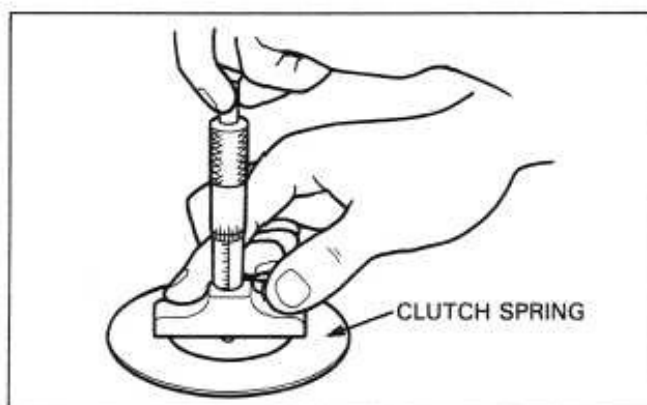

CLUTCH

One-Way Clutch (Type C)

- Check the inside surface of clutch center B for abnormal wear or damage; replace as necessary.
- Measure the I.D. of clutch center B. Replace if the service limit is exceeded.

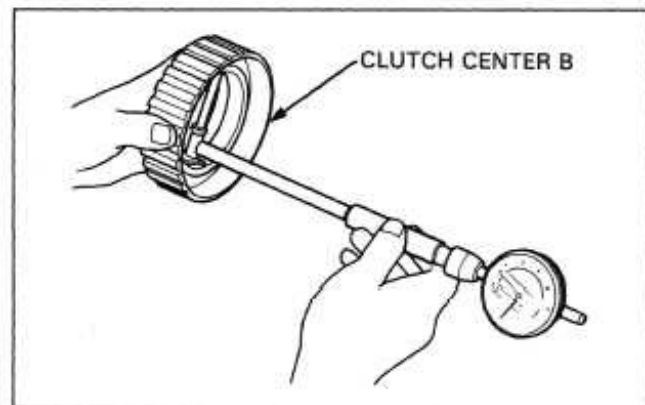

- Check the outside surface of the one-way clutch inner for abnormal wear, replace if necessary.
- Measure the O.D. of the one-way clutch inner. Replace if the service limit is exceeded.

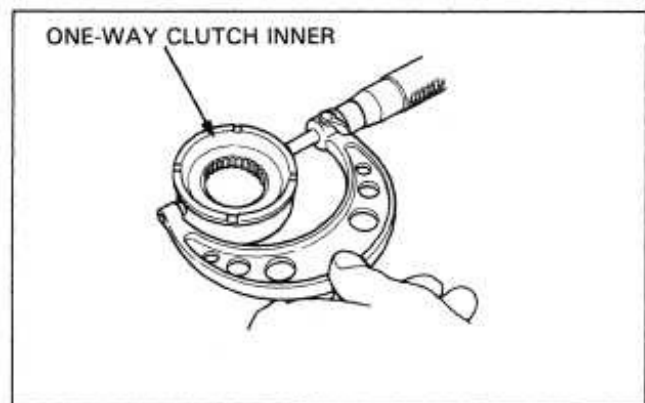

- Check the sprag for damage or excessive wear, replace if necessary.

Reassemble the one-way clutch as follows:

- Install the sprag into the clutch center B, with the flanged side facing up.
- Install the clutch inner into the sprag by turning it in the specified direction with the groove facing up.

Hold the clutch inner and turn clutch center B as shown and check that the clutch center turns in the specified direction but not in the opposite direction. Replace the one-way clutch if the clutch center turns in both directions.

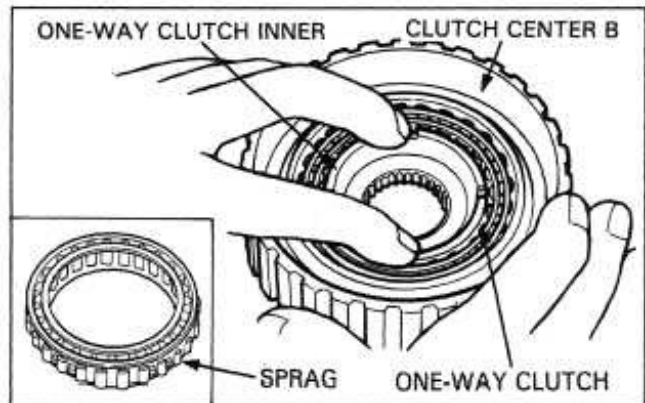

Primary Drive Gear (Type D)

- Check the drive gear grooves for nicks or wear caused by the clutch plates; replace as necessary.
- Measure the I.D. of the primary drive gear. Replace if the service limit is exceeded.

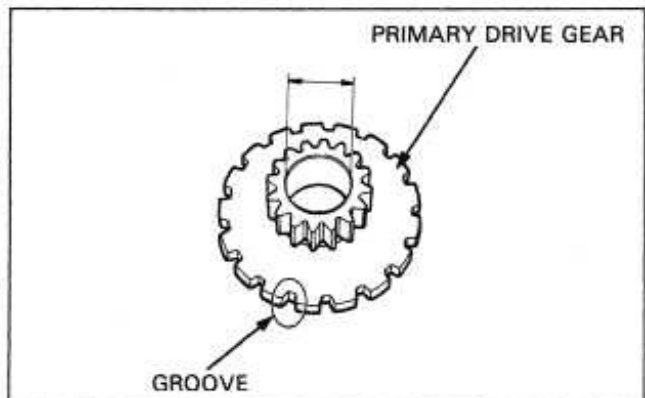

Clutch Center Guide, Collar (Type D)

- Measure the I.D. and/or O.D. of the clutch center guide at the sliding surface.

Replace the guide if the service limit is exceeded.

- Measure the I.D. and/or height of the collar; replace if the service limit is exceeded.

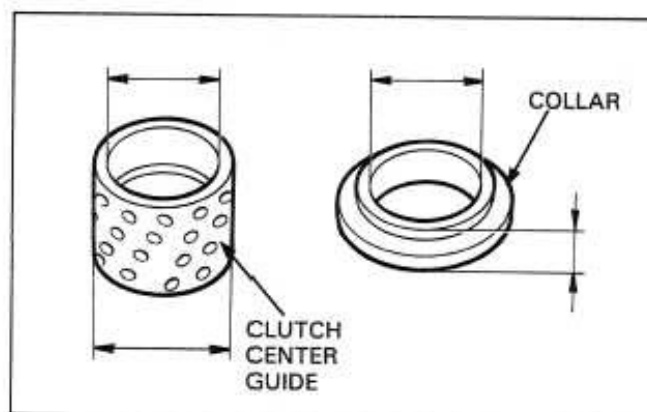

Crankshaft (Type D)

Measure the O.D. of the crankshaft at the clutch center guide sliding surface, replace if the service limit is exceeded.

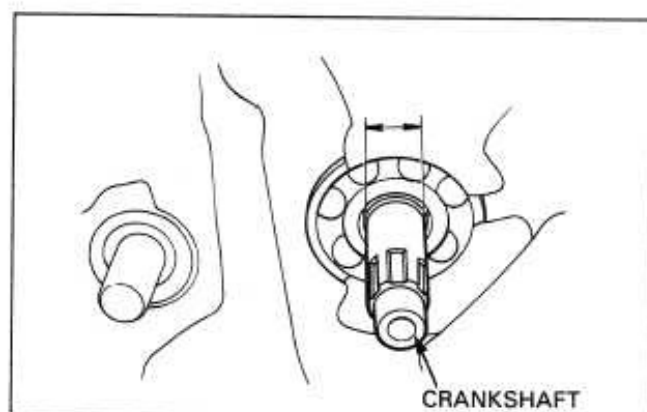

CLUTCH REASSEMBLY

(Type A)

Install the needle bearing or clutch outer guide onto the mainshaft.

Install the clutch outer onto the mainshaft.

NOTE

- If the pump drive sprocket is installed on the mainshaft, align the holes of the clutch outer with the pins on the oil pump drive sprocket.
- If the primary drive gear is the anti-backlash type, install the clutch outer onto the mainshaft while moving the drive sub gear to align the two gear teeth using a screwdriver. Take care not to damage the gear teeth.

Install the thrust washer (if used).

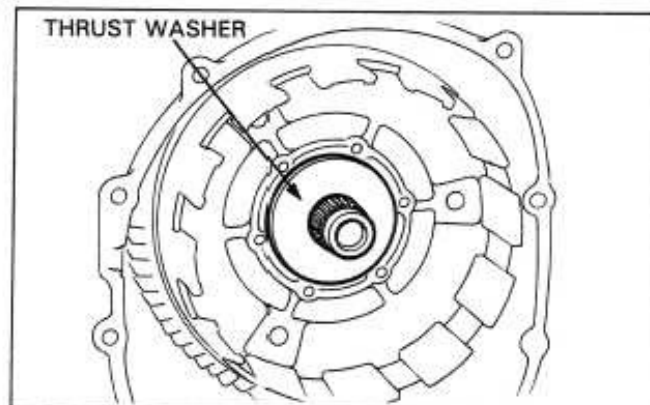
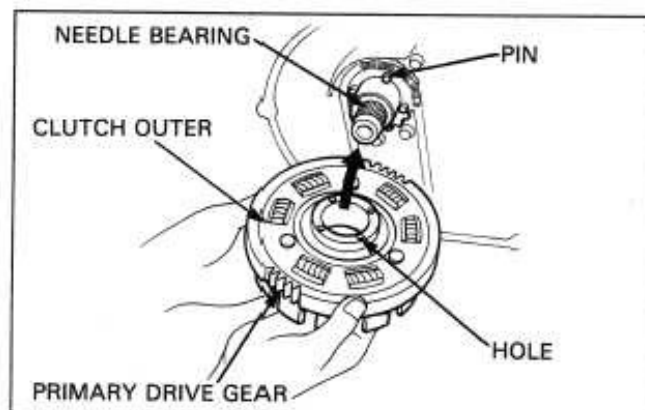

CLUTCH

Coat the clutch discs and plates with clean oil.

Install the pressure plate, discs, plates and clutch center onto the mainshaft in the order shown. If a judder spring is used, install the judder spring and spring seat as shown below.

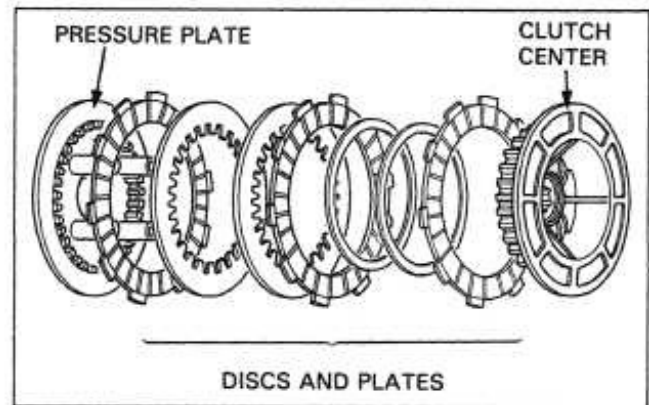

NOTE

- The disc that is installed against the judder spring has a larger I.D. than the other discs.
- If the splines of the clutch center cannot be aligned with the mainshaft splines while installing, change the transmission into any gear position and turn the rear wheel to ease installation.

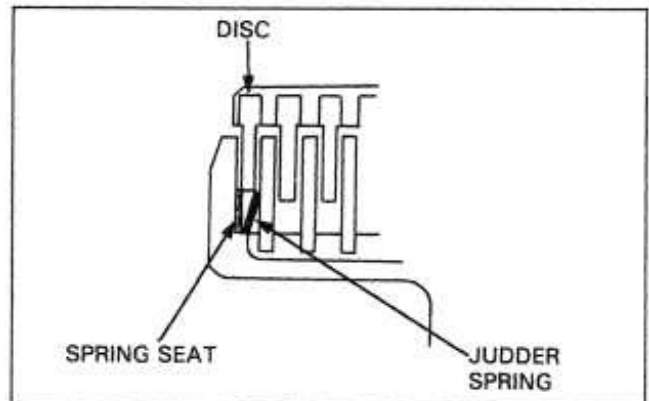

Make sure that the clutch center is installed completely; the grooves of the clutch center must align with the tabs of the pressure plates.

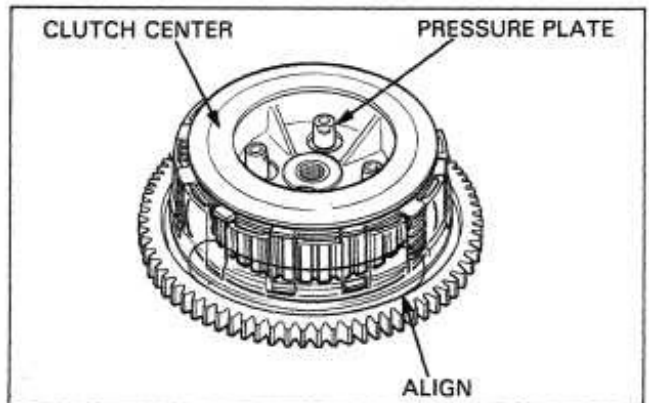

If the clutch is secured with a lock nut:

Install the lock washer onto the mainshaft with the "OUTSIDE" mark facing outside.

If there is no mark, install the lock washer with the convex side facing out.

Install the lock nut and tighten it to the specified torque.

NOTE

- Use a new lock nut if the lock nut was staked.
- Face the chamfered side of the lock nut inward if the lock nut is chamfered.

• If a snap ring is used:

Set the snap ring into the groove in the mainshaft with the chamfered side inward. Turn the snap ring to be sure that it is seated in the groove.

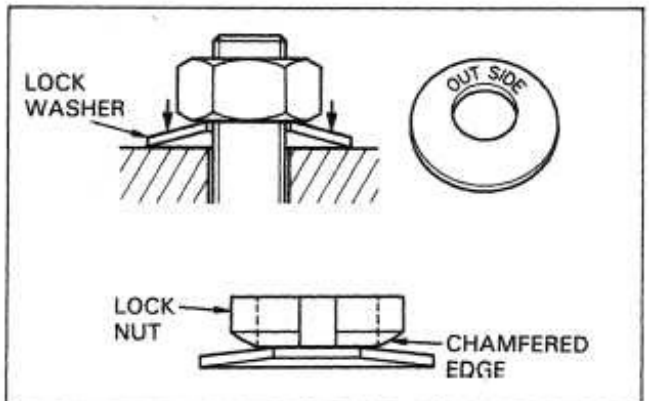

Tighten the lock nut to specified torques using a special tool.

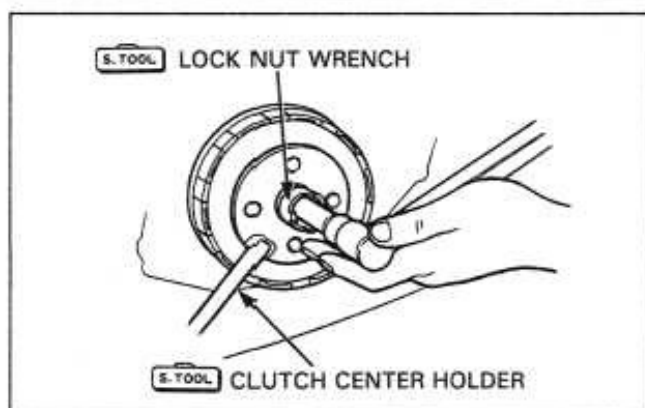

Where a staked lock nut is used:

Stake the nut to the mainshaft.

NOTE

- Replace staked-type lock nuts if the old staked area of the nut aligns with the groove of the shaft after tightening the nut to the specified torque.
- Be careful not to damage the shaft when staking the lock nut.
- Make sure that the peen point covers at least 2/3 of the width of the mainshaft groove.

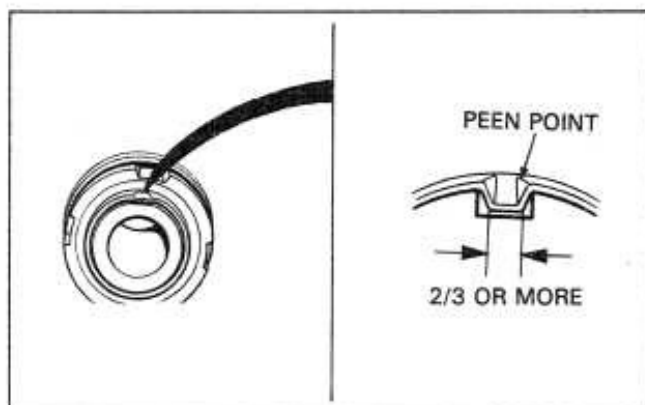

Set the bearing in the lifter plate, then install the clutch springs and the lifter plate.

Install the clutch spring bolts and tighten them in a crisscross pattern in 2 or 3 steps.

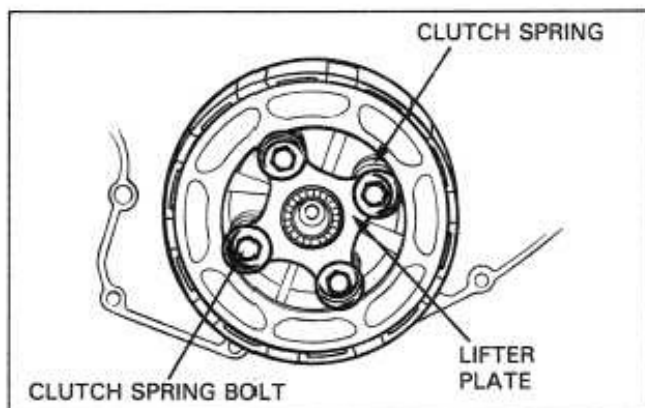

(Type B)

Install the clutch outer guide, needle bearing and clutch outer (see page 11-19).

Install the clutch center.

Install the lock washer and lock nut (see page 11-20).

Tighten the lock nut using the special tool to hold the clutch center.

Stake the lock nut if necessary.

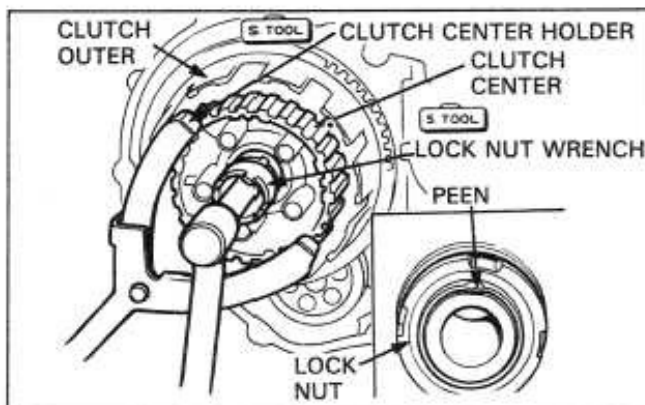

CLUTCH

Coat the clutch plates and discs with clean engine oil.

Install the judder spring seat and spring, discs and clutch plates.

NOTE

- The judder spring and spring seat should be installed as shown.
- The disc that is installed against the judder spring has a larger I.D. than the other discs.

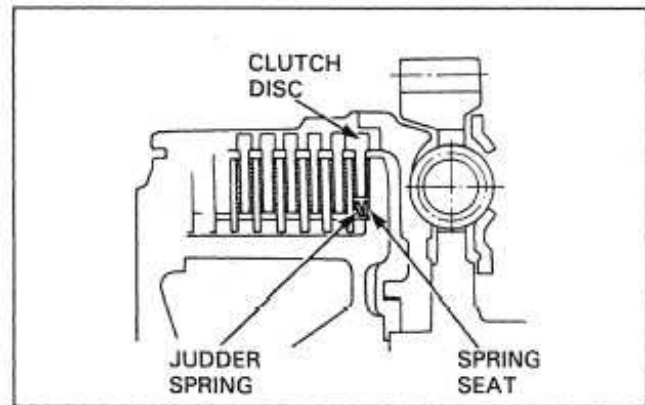

Coat the push rod with grease and install it into the mainshaft.

Install the lifter rod (and steel ball, if removed).

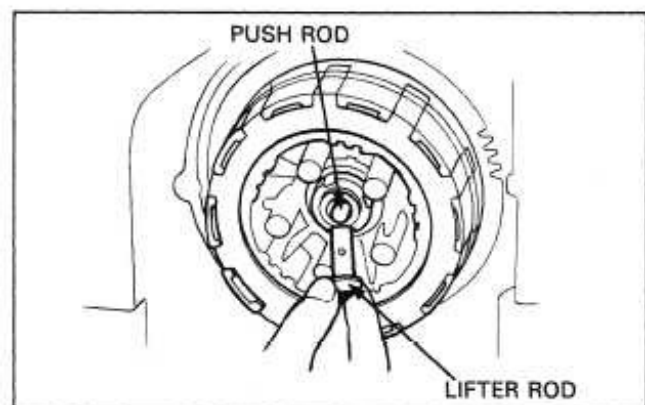

Install the bearing in the lifter plate, then install the clutch springs, pressure plate, washer(s) and clutch spring bolts.

Tighten the clutch spring bolts.

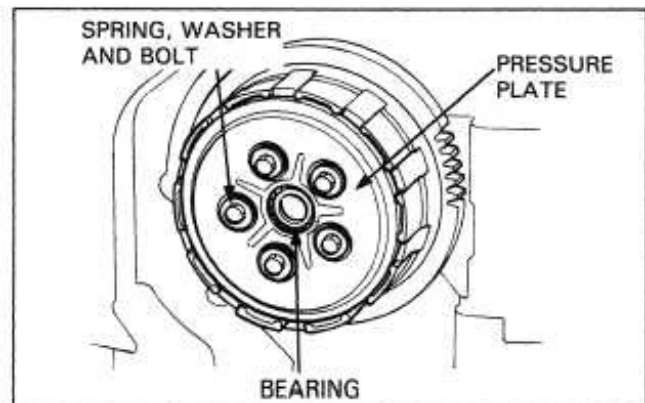

(Type C)

Install the clutch outer guide, needle bearing and clutch outer (see page 11-19).

Install clutch center A and the washer.

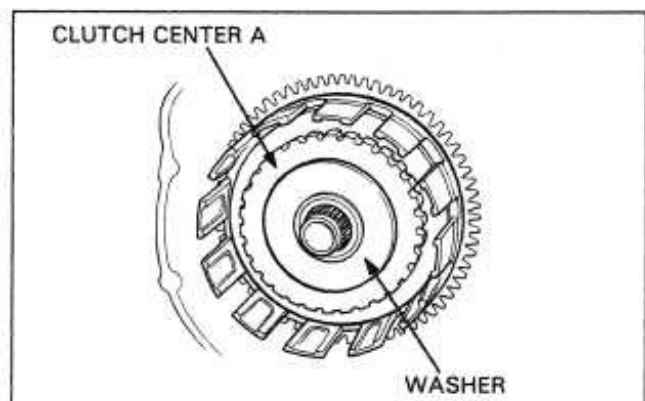

Install the clutch center B, the one-way clutch and one-way clutch inner as an assembly onto the clutch outer.

NOTE

- See page 11-18 for one-way clutch assembly.
- Make sure that the one-way clutch is installed correctly by turning clutch center B. The clutch center should turn in the specified direction freely and should not turn in the opposite direction.

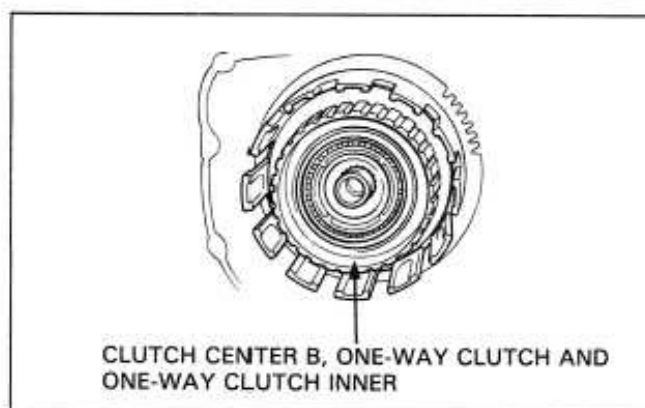

Coat the clutch plates and discs with clean engine oil and install them in the clutch outer and on the clutch center.

NOTE

- Two discs have different groove patterns than the other discs. Install these two in the SECOND and THIRD disc positions (from the mainshaft).
- Do not move clutch center B after installing the discs and clutch plates.

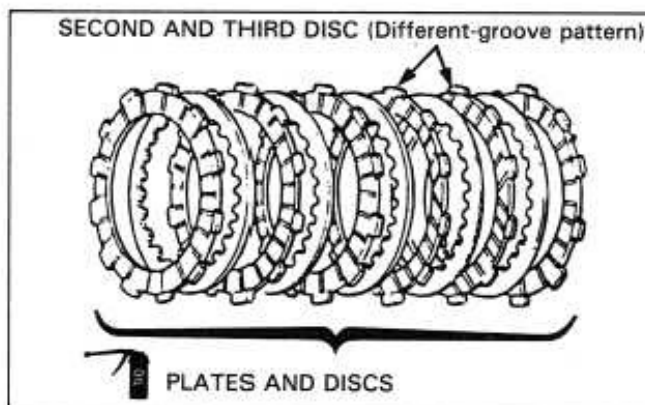

Install the pressure plate.

Install the washers, clutch spring and set plate.

NOTE

- Install the clutch spring with concave side toward the inside.

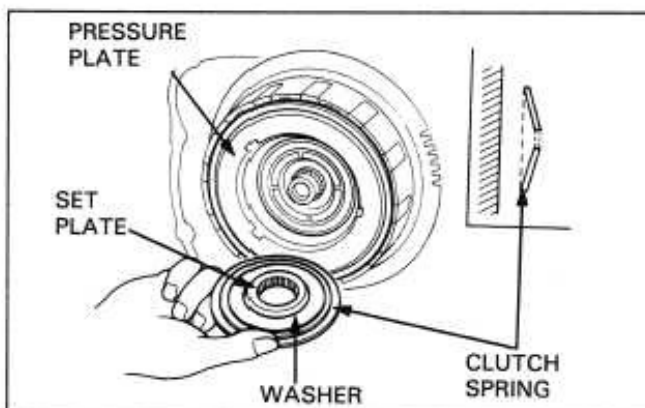

Install the lock washer and lock nut (see page 11-20).

Put the transmission in top gear and apply the rear brake. Then tighten the lock nut to the specified torque.

NOTE

- If the engine is not in the frame, shift the transmission into top gear, hold the drive sprocket with the universal holder, and tighten the lock nut.

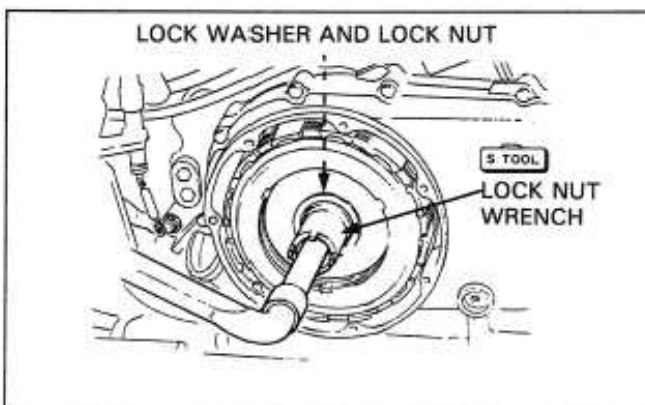

CLUTCH

Coat the push rod with grease and install it in the mainshaft.

Install the lifter rod.

Untie the clutch lever from the handlebar.

Install the bearing onto the lifter plate.

Install the lifter plate and secure it with the set ring.

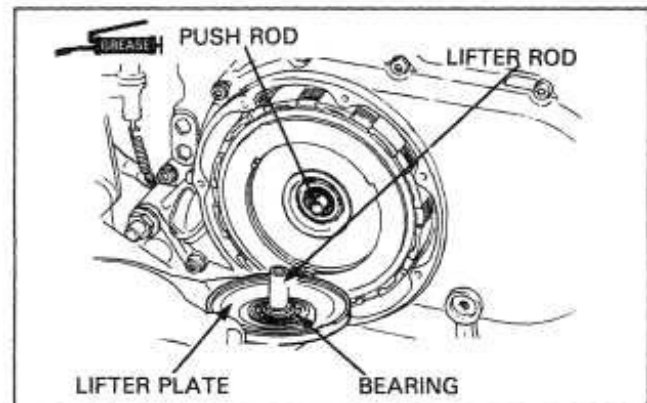

(Type D)

Install the clutch springs on the clutch outer.

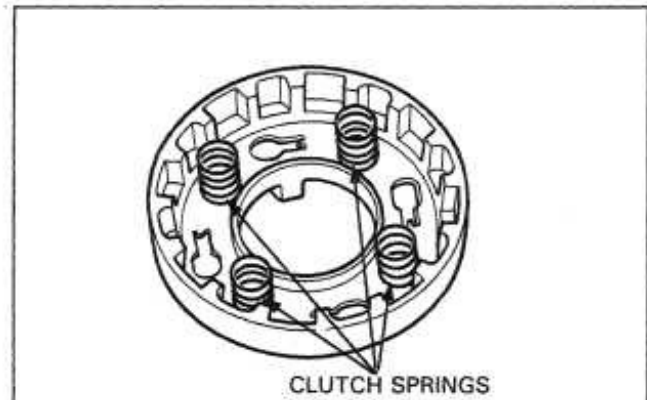

Assemble the drive plate in the clutch outer.

Install the clutch disc, clutch plate and primary drive gear.

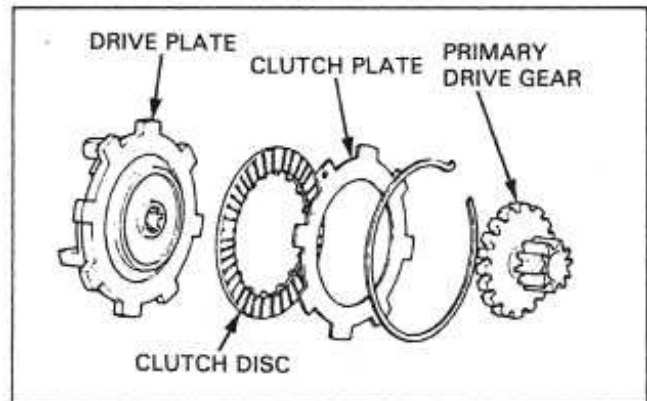

Compress the clutch springs with the clutch spring compressor, then install the set spring in the groove of the clutch outer.

Remove the tool.

 S TOOL

CLUTCH SPRING COMPRESSOR 07960-0110000

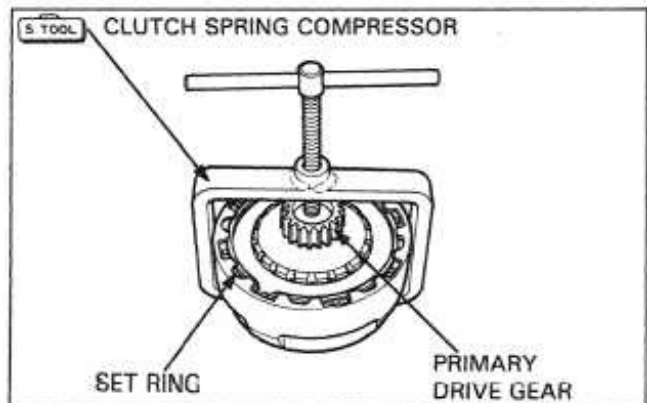

Install the clutch damper springs.

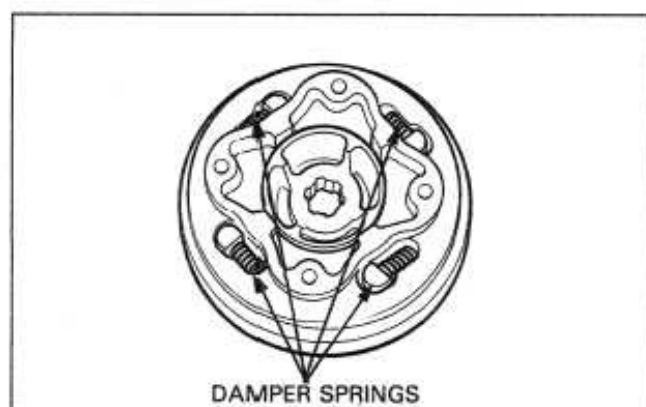

Install the collar and clutch center guide onto the crankshaft.

Install the primary driven gear onto the mainshaft and secure it with a snap ring.

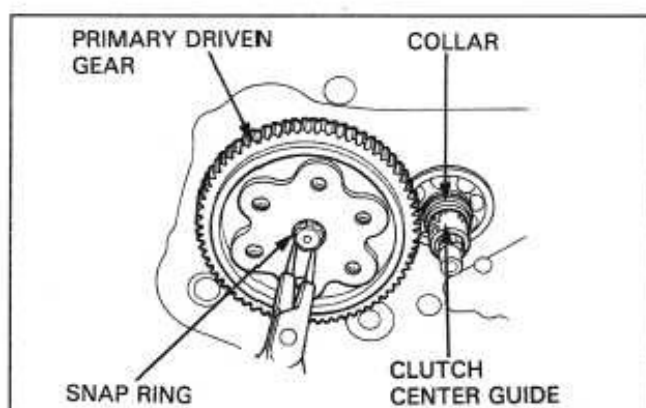

Install the clutch assembly onto the crankshaft.

Install a new lock washer B (tongued washer) onto the mainshaft.

NOTE

- Replace lock washer B with new one whenever it is removed.

Install lock washer A with the "OUTSIDE" mark facing outside. If there is no mark, install the lock washer with the convex side toward the outside.

Install the lock nut with the chamfered edge toward the inside.

Hold the clutch outer using a special holder tool and tighten the lock nut to the specified torque.

Bend the tab of lock washer B up into the lock nut groove.

NOTE

- If the tab and groove aren't aligned, turn the lock nut in the tightening direction to align; do not loosen the nut to set the locking tab.

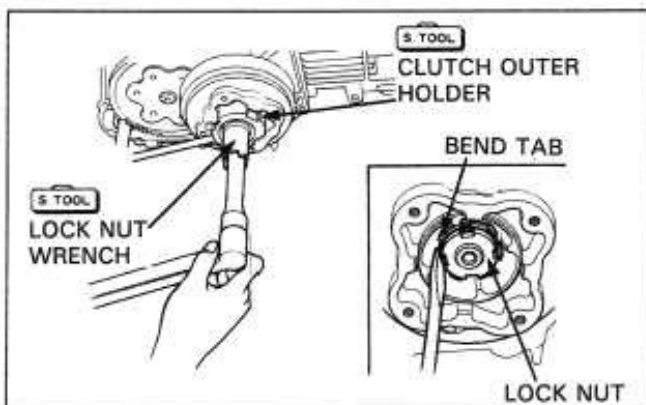
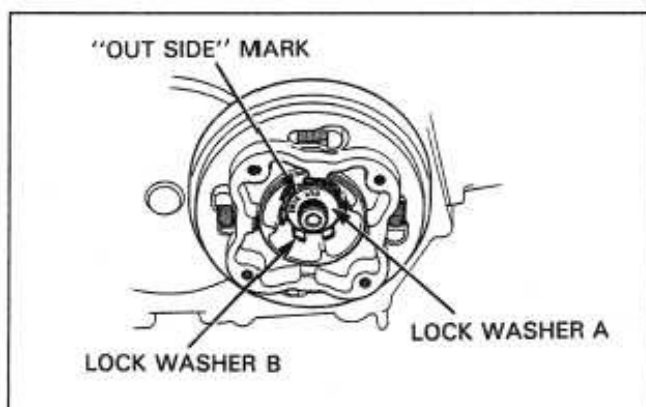

CLUTCH

Install a new gasket onto the clutch outer.

Install the clutch outer cover and tighten the mounting screws.

Install the lifter, spring and oil through guide onto the clutch assembly.

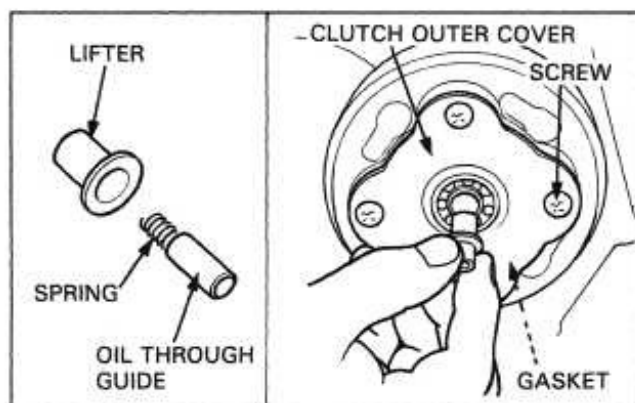

CLUTCH LIFTER REASSEMBLY

(Type A and a part of type B)

Coat the lifter arm and dust seal with grease.

Install the lifter arm and return spring.

Drive in a new spring pin using a pin driver until the pin does not interfere with the lifter arm.

Reset the return spring in the place.

Install the lifter rod into the cutout in the lifter arm.

Install the crankcase cover (see the Model Specific manual).

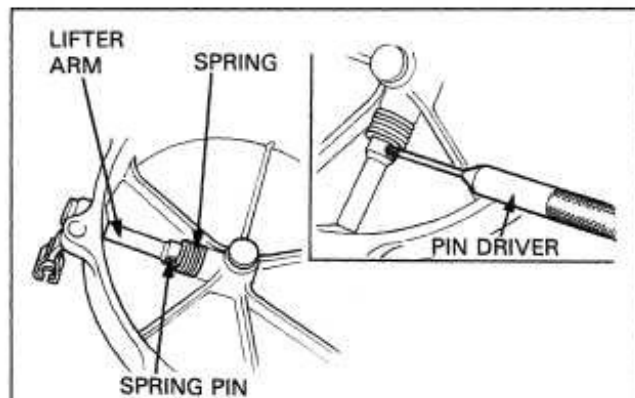

(Type D)

Coat the lifter arm with grease.

Replace the O-ring with new one, and install the return spring and lifter arm in the crankcase cover.

Install the stopper pin into the pin hole on the crankcase cover.

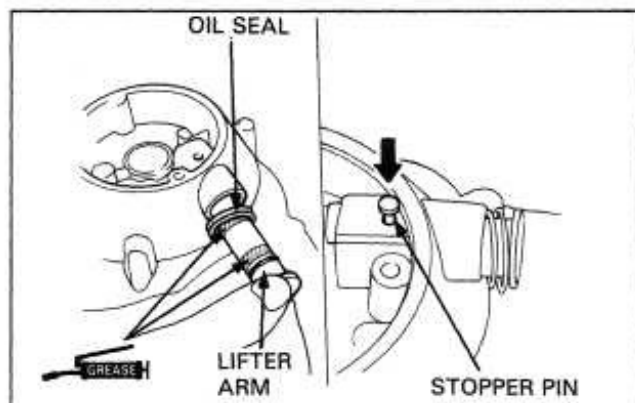

Install the lifter plate and set plate, then tighten the screw.

Install the lifter rod by aligning the boss of the lifter rod with the groove in the crankcase cover.

Install a new gasket and the clutch lifter cover. Tighten the screws.

Install the crankcase cover (see the Model Specific manual).

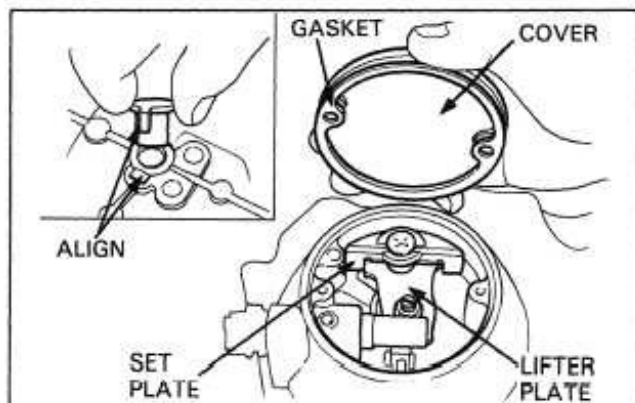

HYDRAULIC CLUTCH SYSTEM SERVICE

FLUID REPLACEMENT

Before removing the reservoir cover, turn the handlebar until the reservoir is level.

Place a rag over painted, plastic or rubber parts whenever the system is serviced.

Remove the reservoir cover, diaphragm cover and diaphragm.

CAUTION

- Spillings brake/clutch fluid on painted, plastic or rubber parts will damage them.

Connect a bleed hose to the bleed valve.
Loosen the bleed valve and pump the clutch lever.
Stop operating the lever when no fluid flows out of the bleed valve.

Close the bleed valve.

Fill the reservoir with the recommended fluid from an unopened container. Do not allow foreign material to enter the system when refilling the reservoir.

Install the diaphragm and reservoir cover.

Install and tighten the cover screws.

▲ WARNING

- Using the wrong fluid will cause loss of braking efficiency.
- Contaminated fluid can clog the system, causing a loss of braking ability.

Connect the brake bleeder to the bleed valve.

Pump the brake bleeder and loosen the bleed valve.

Add clutch fluid when the fluid level in the master cylinder reservoir is low.

Repeat above procedure until air bubbles do not appear in the bleed hose.

NOTE

- Be sure the fluid reservoir is parallel to the ground before removing the cover and diaphragm.
- If air enters the bleeder from around the bleed valve threads, seal the threads with teflon tape.

If the brake bleeder is not available, perform the following procedure.

Connect a bleed hose to the bleed valve.

Loosen the slave cylinder bleed valve and pump the clutch lever.

Stop operating the lever when no fluid flows out of the bleed valve.

Close the bleed valve. Fill the reservoir, and install the diaphragm.

Pump up the system pressure with the lever until there are no air bubbles in the fluid flowing out of the reservoir small hole and lever resistance is felt.

Then bleed the system.

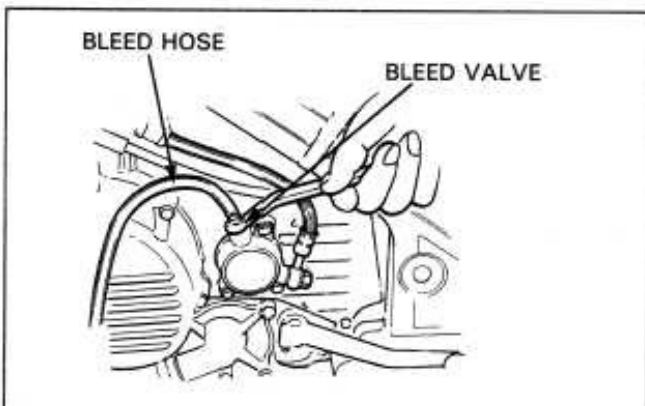
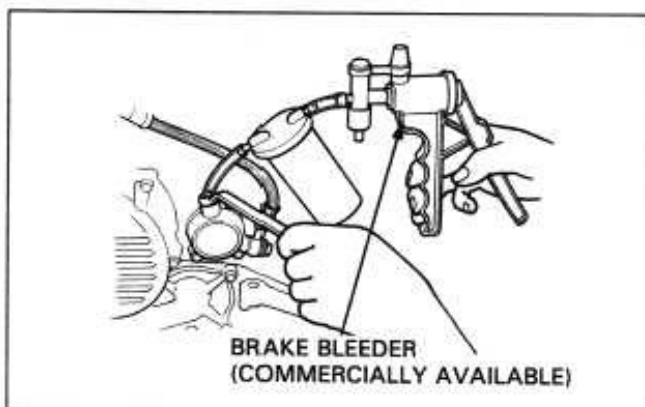
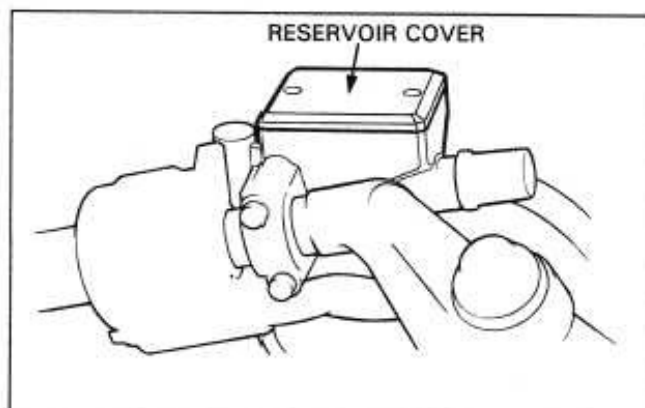

CLUTCH

AIR BLEEDING

- 1) Squeeze the clutch lever, open the bleed valve 1/2 turn then close the valve.

NOTE

- Do not release the clutch lever until the bleed valve has been closed.
- Check the fluid level often while bleeding the system to prevent air from being pumped into the system.

- 2) Release the clutch lever slowly and wait several seconds after it is fully released, before repeating the procedure.

Repeat the above procedures until air bubbles no longer appear at the end of the hose.

Tighten the bleed valve to the specified torque.

Fill the clutch fluid reservoir to the upper level.

Install the diaphragm, diaphragm cover and reservoir cover.

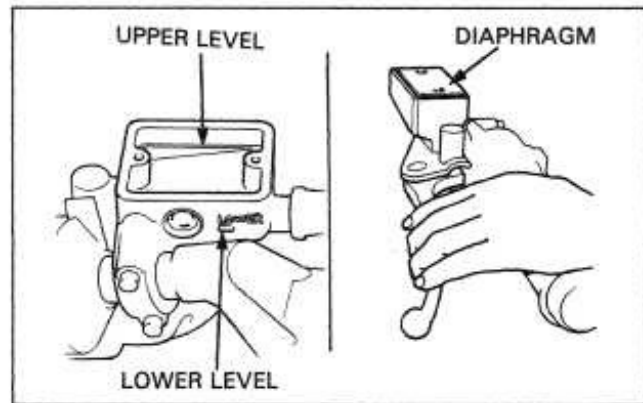

CLUTCH MASTER CYLINDER

Removal/Disassembly

Place a rag over painted, plastic or rubber parts whenever the system is serviced.

CAUTION

- Spilled fluid will damage painted, plastic, or rubber parts.

Disconnect the clutch switch wires, and remove the clutch hose bolt and two sealing washers.

Cover the end of the hose with a clean rag to prevent contamination of the system. Then secure the hose to the handlebar.

Remove the holder bolts and holder, then remove the master cylinder from the handlebar.

Remove the clutch lever pivot bolt, nut and clutch lever.

Remove the push rod and boot.

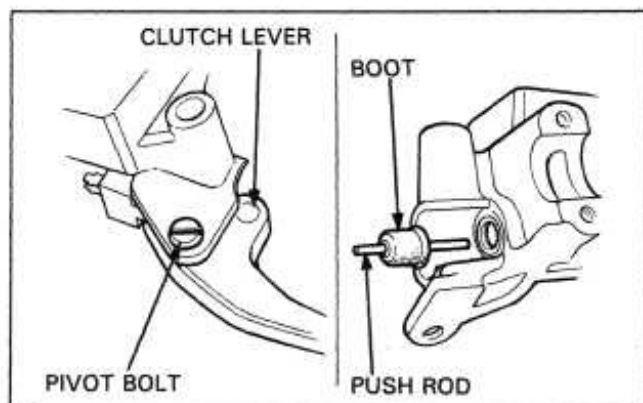
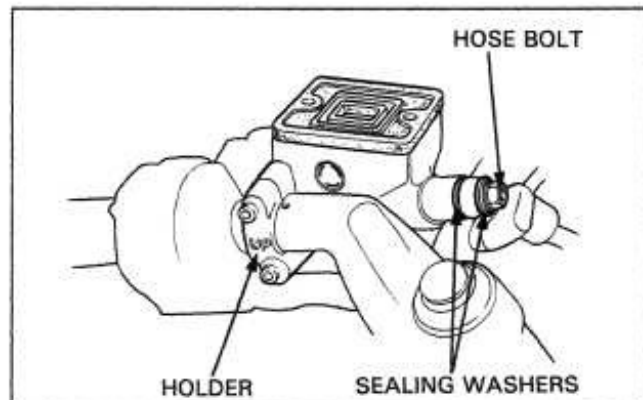
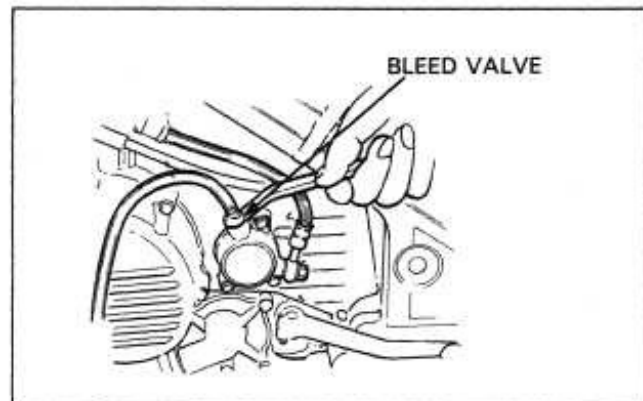

Remove the snap ring from the master cylinder.

S TOOL

SNAP RING PRIERS

07914-3230001 or equivalent tool commercially available

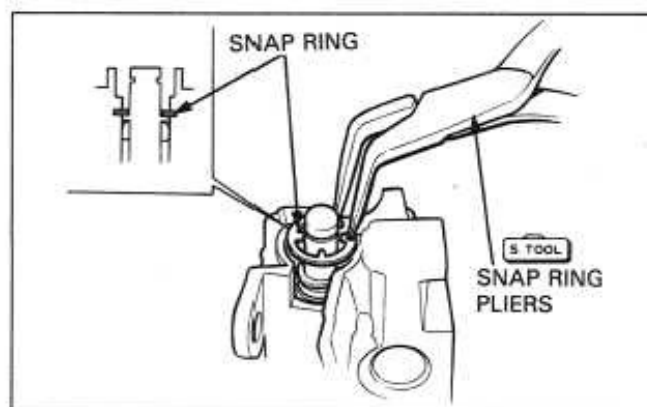

Remove the washer, piston/secondary cup, primary cup and spring from the master cylinder body.

Replace the master piston components as a set.

CAUTION

- Replacing individual master piston components can cause clutch system failure.

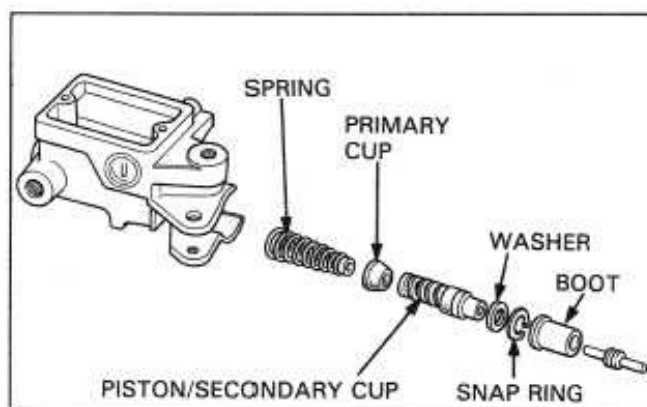

Inspection

Check the primary cup and secondary cup for wear, damage or deterioration and replace as necessary. Measure the master piston O.D., replace if the service limit is exceeded.

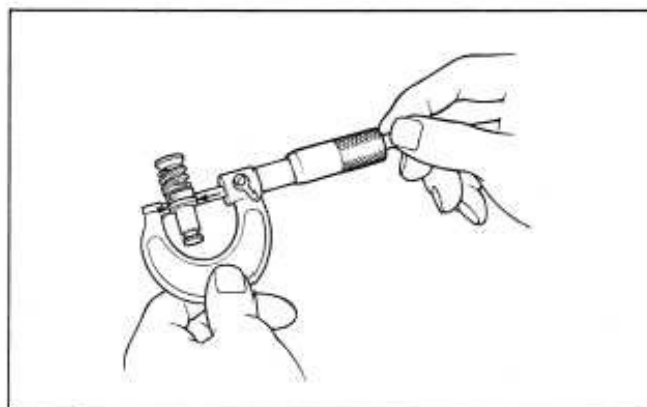

Check the master cylinder for scores or nicks and replace as necessary.

Measure the master cylinder I.D. in X and Y directions; replace if the service limit is exceeded.

NOTE

- Replace the piston, spring and cups as a set.

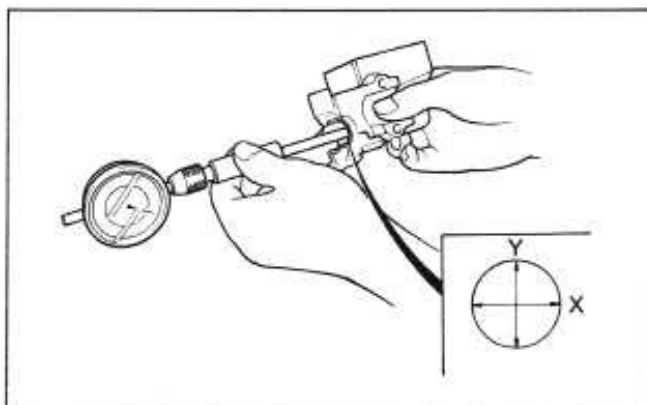

CLUTCH

Assembly/Installation

Clean all parts thoroughly.

Coat the primary and secondary cups with clean brake fluid before assembly.

Install the spring in the master cylinder with the small end out.

Install the primary cup and piston/secondary cup.

CAUTION

- Allowing the lips to turn inside out when installing the cups will result in brake system failure.

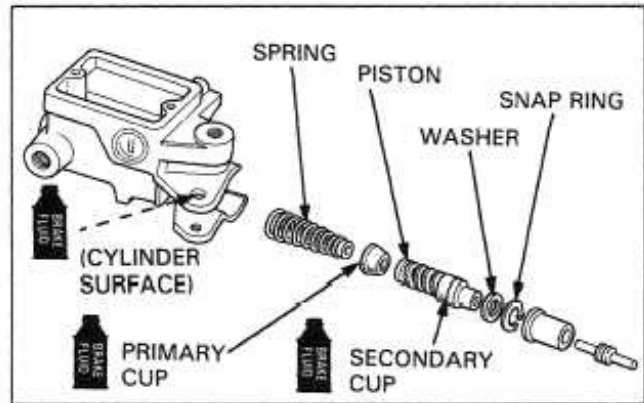

Install the washer and snap ring making sure the snap ring is seated firmly in the groove.

S TOOL

SNAP RING PLIERS

07914-3230001 or equivalent tool commercially available

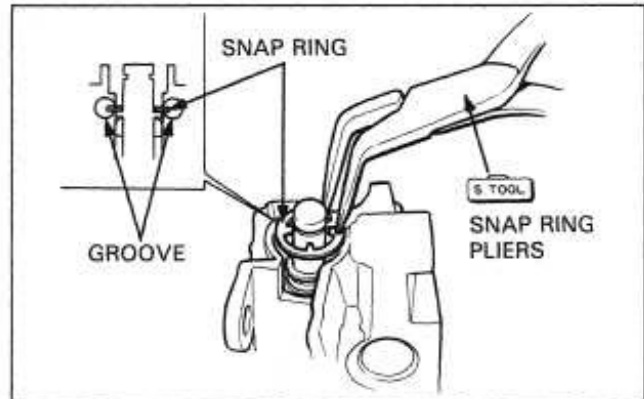

Install the boot and push rod.

Set the push rod end piece into the clutch lever hole. Then install the lever with the end piece over the push rod.

Screw in the pivot bolt making sure that the lever moves smoothly, then tighten the pivot nut securely.

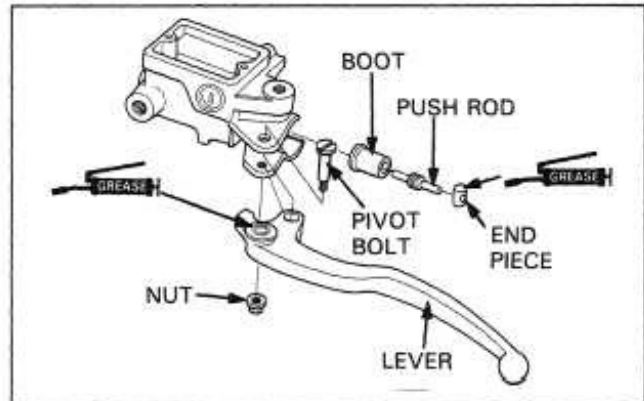

Place the master cylinder on the handlebar and install the holder with the "UP" mark facing up.

Align the end of the holder with the handlebar punch mark.

Tighten the upper holder mounting bolt first, then tighten the lower bolt.

Install the clutch hose with the bolt and two new sealing washers.

Connect the clutch switch wires to the switch terminals. Fill the reservoir and bleed the clutch system (page 11-28).



CLUTCH SLAVE CYLINDER

Place a rag over painted, plastic or rubber parts whenever the system is serviced.

CAUTION

- Spilled fluid will damage painted, plastic, or rubber parts.

Remove the slave cylinder mounting bolts and then remove the slave cylinder from the crankcase.

NOTE

- Do not disconnect the clutch hose until the piston has been removed.

Inspect the piston seals for signs of leakage.

Disassemble the slave cylinder and replace the piston seal as required.

Place a clean pan under the slave cylinder to catch the draining fluid and squeeze the clutch lever slowly to push out the piston.

Drain the clutch fluid. Temporarily install the slave cylinder then disconnect the clutch hose.

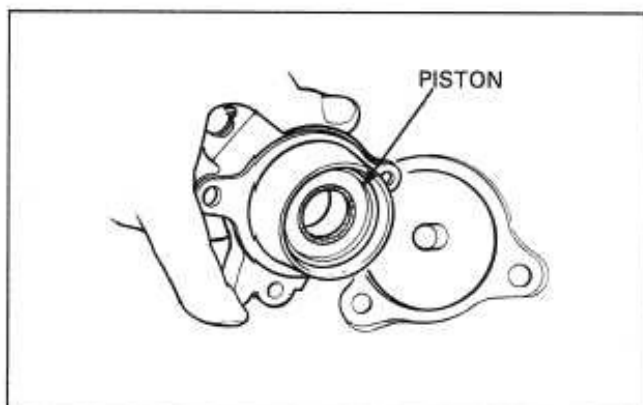
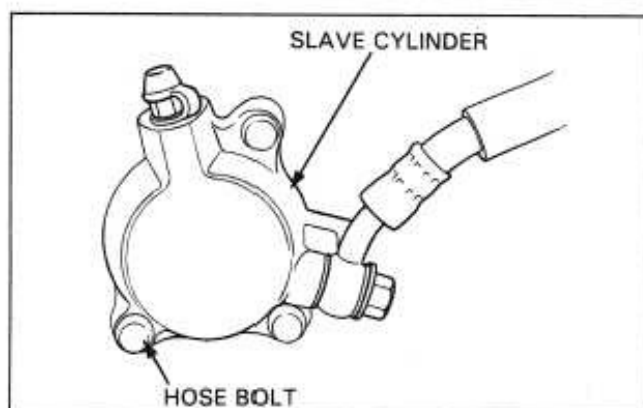

Remove the spring from the piston.

Check the piston and cylinder for scoring or scratches.

Remove the oil seal and piston seal from the piston and discard them.

The seals must be replaced with new ones whenever they have been removed.

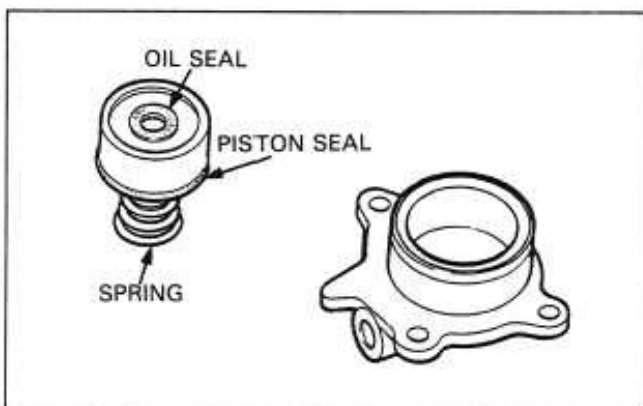
**Assembly**

Assemble the slave cylinder in the reverse order of disassembly.

Apply a medium grade of hi-temperature silicone grease or brake fluid to the new piston seal and oil seal.

Carefully seat the piston seal in the piston groove. Install the oil seal. Place the piston in the cylinder with the seal end facing out.

Install the spring in the cylinder with small end toward the piston.

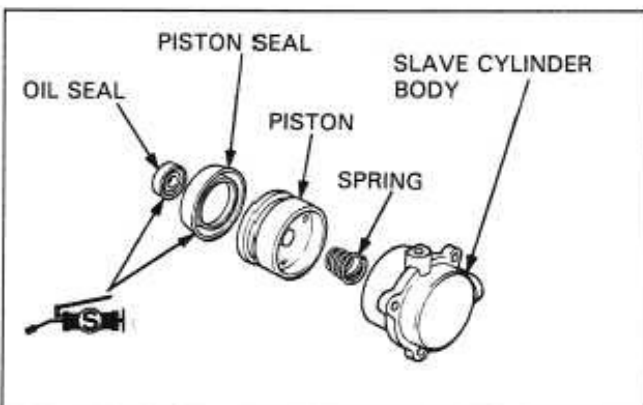

CLUTCH

Make sure that the clutch lifter push rod is installed properly.

Install the dowel pins and a new gasket onto the slave cylinder and install the cylinder by aligning the push rod with the oil seal hole.

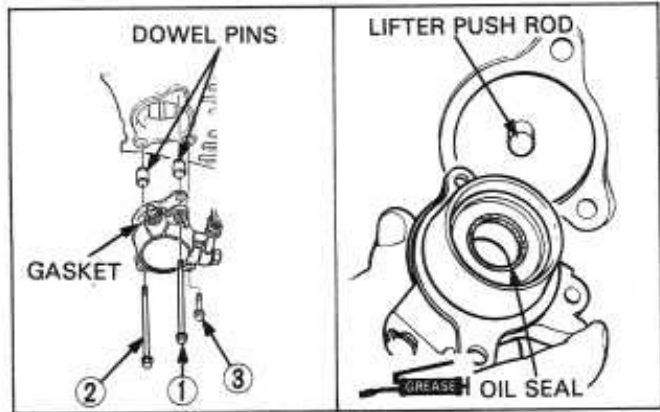

Tighten the mounting bolts to the specified torque.

NOTE

- Some models have dowel bolts instead of dowel pins to secure the slave cylinder positions.
- Note the location of the dowel bolts or dowel pins for positioning the slave cylinder.
- Tighten the bolts in 2 or 3 steps in a crisscross pattern starting from the dowel bolt or the dowel pin bolt.

Connect the clutch hose with the hose bolt and two new sealing washers, then tighten the hose bolt to the specified torque.

Fill the clutch fluid reservoir and bleed the clutch system (page 11-28).

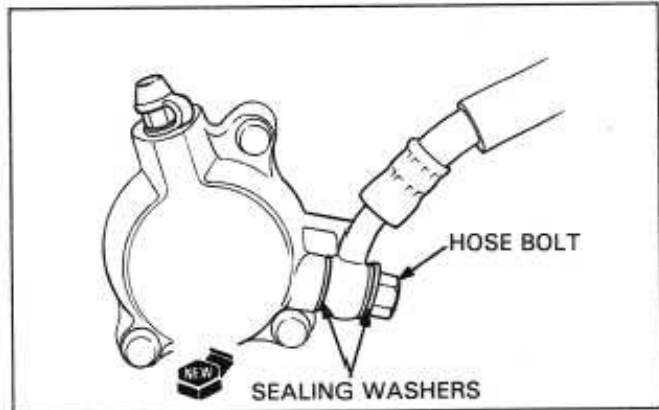

12. V-MATIC BELT DRIVE SYSTEM

SERVICE INFORMATION	12-1	DRIVE BELT	12-5
TROUBLESHOOTING	12-1	DRIVE PULLEY	12-6
SYSTEM DESCRIPTION	12-2	CLUTCH/DRIVEN PULLEY	12-10

SERVICE INFORMATION

- Avoid getting grease and oil on the V-belt and pulley drive faces in order to prevent belt slippage.
- Refer to the Model Specific manual for removal/installation of the left crankcase cover and specific clutch maintenance.

TROUBLESHOOTING

Engine starts but vehicle won't move

- Worn drive belt
- Damaged ramp plate
- Worn or damaged clutch lining

Engine stalls or vehicle creeps

- Broken clutch shoe spring

Poor performance at high speed or lack of power

- Worn drive belt
- Weak driven face spring
- Worn weight roller
- Faulty driven pulley face

V-MATIC BELT DRIVE SYSTEM

SYSTEM DESCRIPTION

OPERATION

HONDA V-MATIC provides variable drive ratios between the engine and rear wheel according to the engine speed and load. It accomplishes this with two sets of pulleys, drive and driven, connected by a drive belt. The drive pulley is attached to the engine crankshaft. The driven pulley is attached to a shaft that incorporates a centrifugal clutch. In the V-Matic Drive, there is a final gear reduction between the driven pulley and rear wheel, providing an increase in torque.

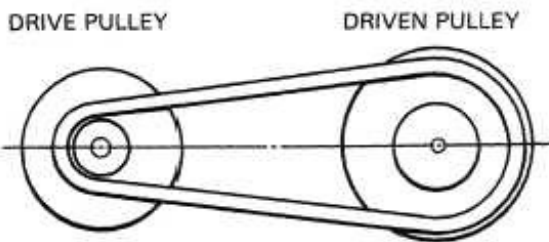
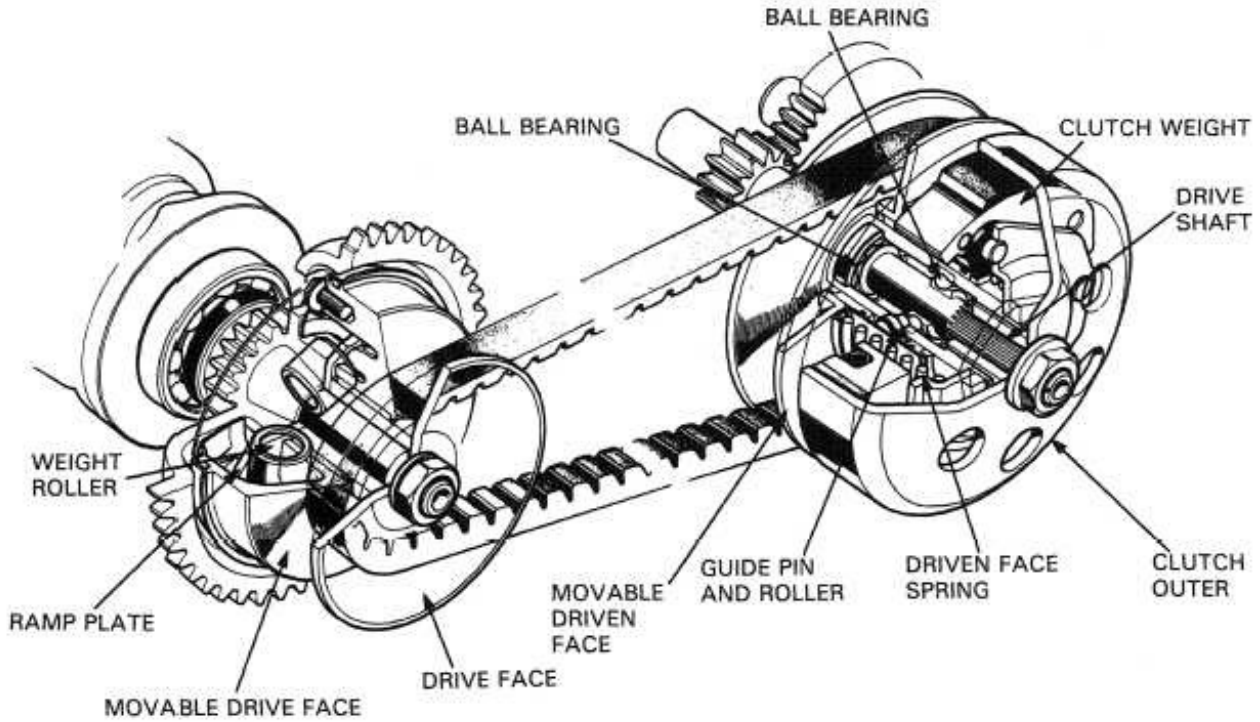

When the engine is running at low speed, the unit increases or multiplies torque. This delivers more torque than a higher engine speed at a greater drive ratio.

REDUCTION: LOW

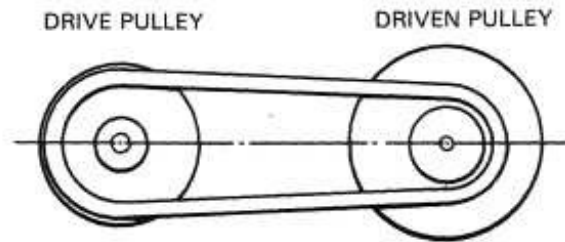

As the engine rpm increases, or the load on the rear wheel decreases, centrifugal force on the weight rollers throws the rollers outward. When the rollers are forced outward, they push the movable face of the drive pulley closer to the drive face. The result is a reduced drive ratio between the driven and drive pulleys.

REDUCTION: HIGH

DRIVE PULLEY OPERATION

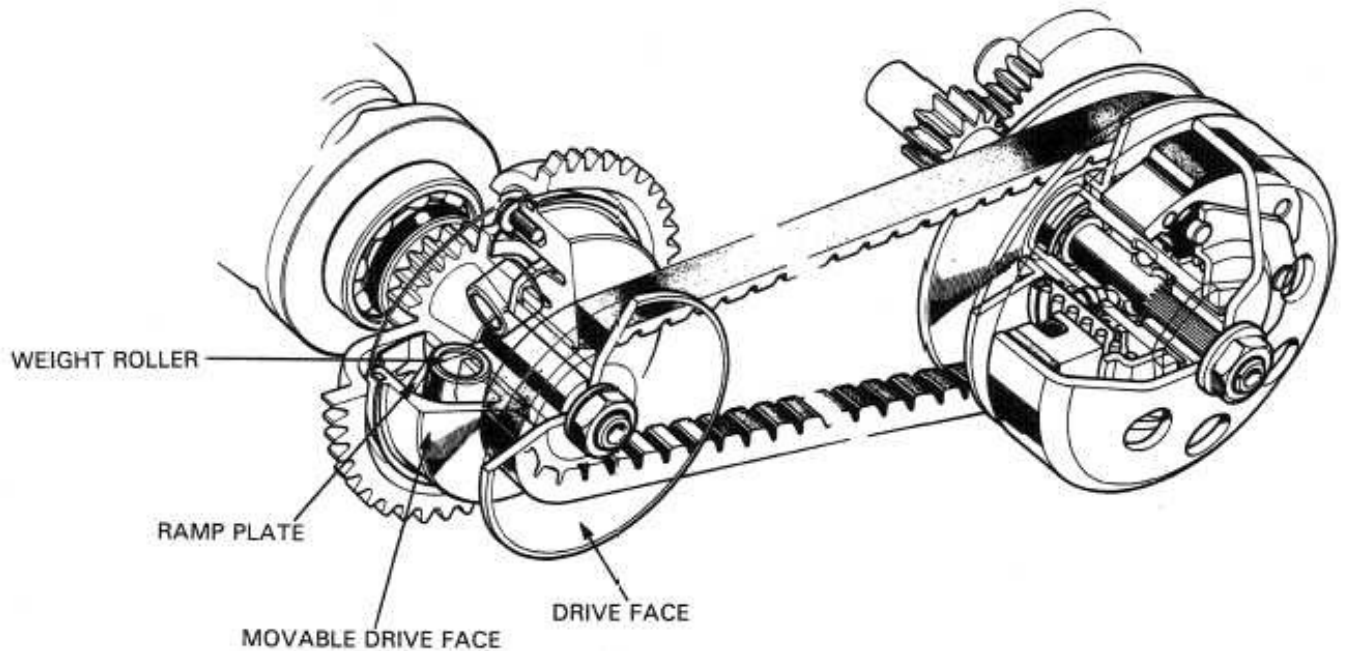

The drive pulley consists of a fixed and a movable face. The movable face is capable of sliding axially on the shaft of the fixed face. The ramp plate, which pushes the weight rollers against the drive face, is attached to the shaft of the drive face with a nut.

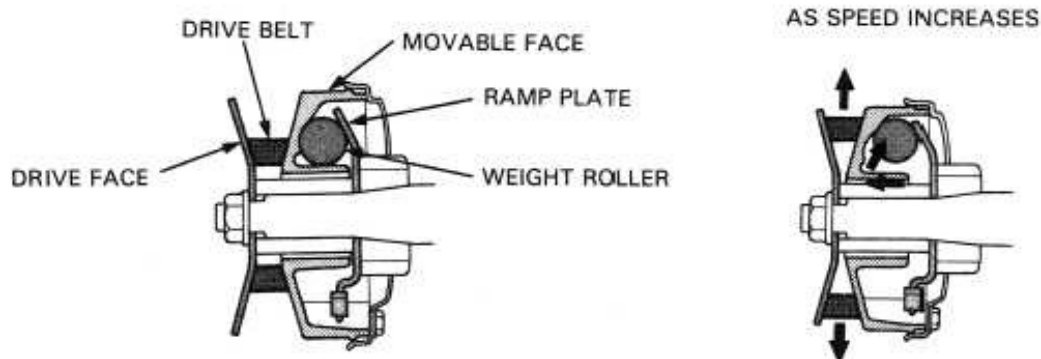

As the engine rpm increases, centrifugal force on the weight rollers is increased. This pushes the movable drive face toward the fixed face. This reduces the drive ratio by allowing the drive belt to run on a pulley of greater diameter.

V-MATIC BELT DRIVE SYSTEM

DRIVEN PULLEY/CENTRIFUGAL DRY CLUTCH

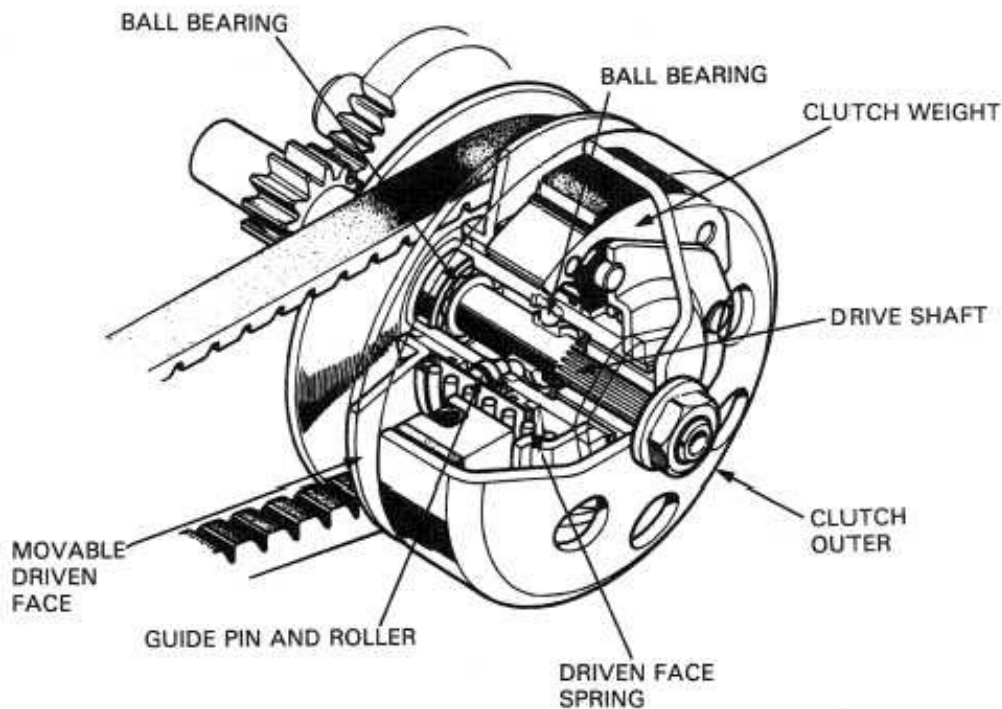

The centrifugal clutch is disengaged when the engine speed is low. When engine speed increases, the rotating clutch shoes of the clutch weight will expand as the centrifugal force increases. In this way, the clutch is automatically engaged.

The drive belt is pushed out towards the drive face circumference of the drive pulley as the engine speed increases. As the belt remains constant in length, the belt, in turn, is pulled in toward the center of the driven face, pushing out the movable driven face and compressing the driven face spring.

By this mechanism, the diameter of the belt on the driven pulley decreases at high engine speed. When the engine speed decreases, the belt is pulled back towards the center of the drive pulley releasing the tension on the belt. This allows the driven face spring to move the movable driven face toward the original position, pushing the belt back toward the circumference of the driven pulley.

In the manner described above, the reduction ratio varies with engine speed automatically, without the need to manually shift between gear ratios.

DRIVE BELT

REMOVAL

Remove the left crankcase cover (see Model Specific manual).

Hold the clutch outer using the universal holder and remove the nut and clutch outer.

 S TOOL

UNIVERSAL HOLDER

07725-0030000

CAUTION

- Use the special tool when loosening the lock nut. Holding the rear wheel or rear brake will damage the final reduction system.

Squeeze the drive belt into the pulley groove as shown so that it slackens enough to remove the driven pulley from the drive shaft.

Remove the driven pulley/clutch with the drive belt in place.

Remove the drive belt from the driven pulley groove and drive pulley groove.

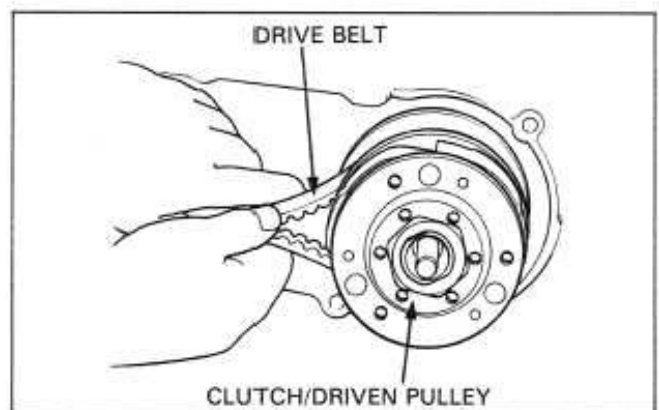
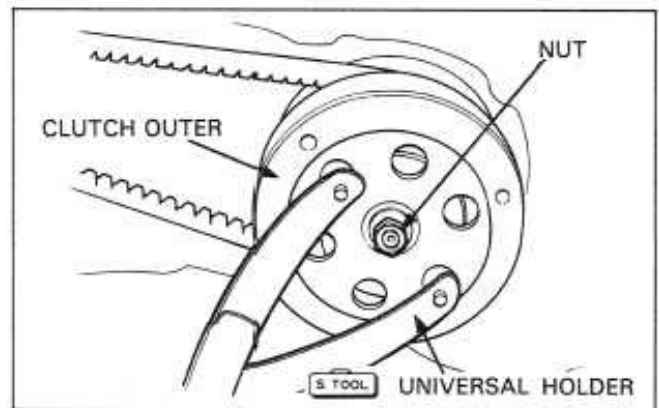

INSPECTION

Check the drive belt for cracks, pry separation and wear; replace as necessary.

Measure the width of the drive belt as shown.

Replace the belt if the service limit is exceeded.

NOTE

- Use only a genuine HONDA replacement drive belt.
- Do not get oil or grease on the drive belt or pulley faces. Clean off any grease or oil before reinstalling.

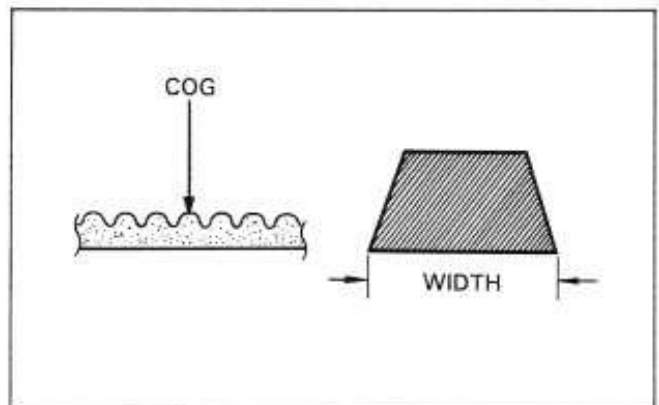

INSTALLATION

Temporarily install the driven pulley/clutch assembly on the drive shaft.

Turn the pulley clockwise and spread the faces apart while installing the drive belt.

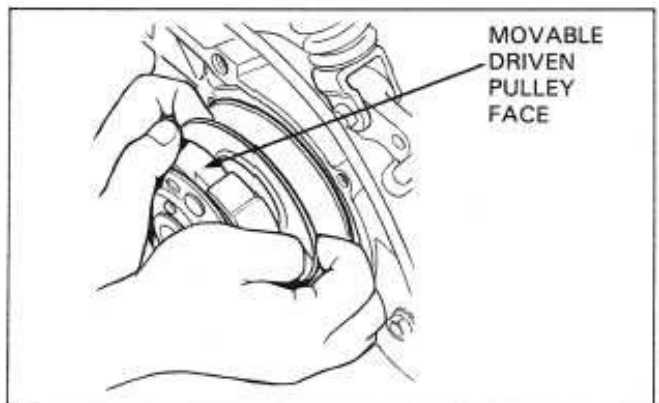

V-MATIC BELT DRIVE SYSTEM

Remove the pulley assembly once with the drive belt installed.

NOTE

- Hold the pulley faces apart preventing them from closing.

Put the drive belt over the drive pulley.

Reinstall the driven pulley on the drive shaft with the drive belt attached.

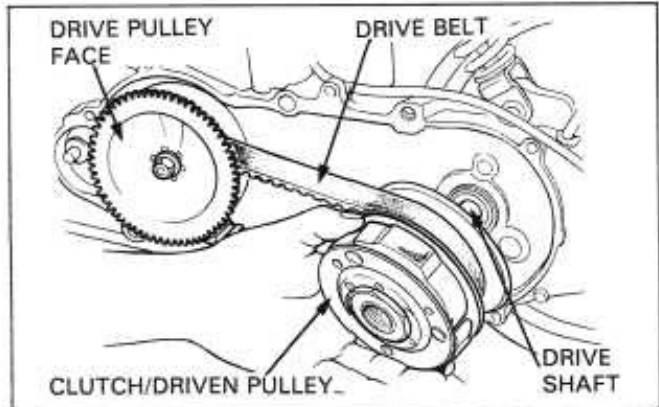

Install the clutch outer and the universal holder. Tighten the nut to the specified torque.

S TOOL

UNIVERSAL HOLDER

07725-0030000

Reinstall the left crankcase cover (see Model Specific manual).

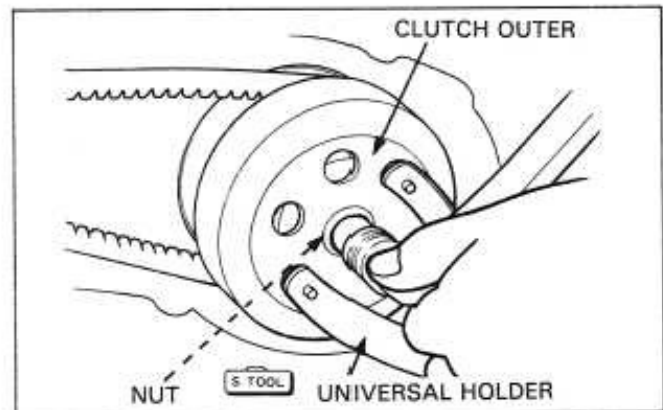

DRIVE PULLEY

REMOVAL

Remove the left crankcase cover (see Model Specific manual).

Hold the drive pulley face using the drive pulley holder and remove the nut and washer.

Remove the drive pulley face.

S TOOL

DRIVE PULLEY HOLDER

07923-KM10000

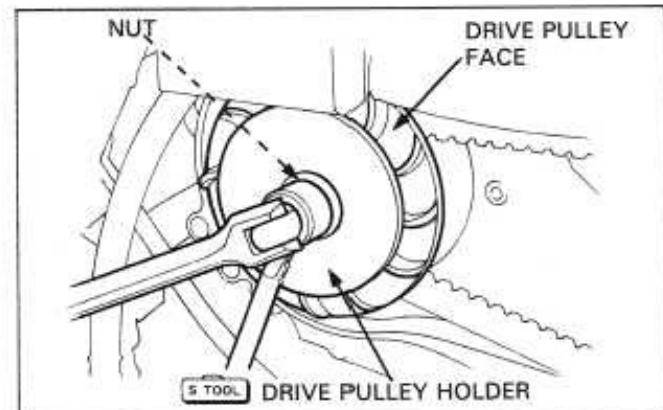

If the drive pulley holder cannot be used, remove the cooling fan at the right side of the crankshaft, and hold the flywheel with the universal holder.

S TOOL

UNIVERSAL HOLDER

07725-0030000

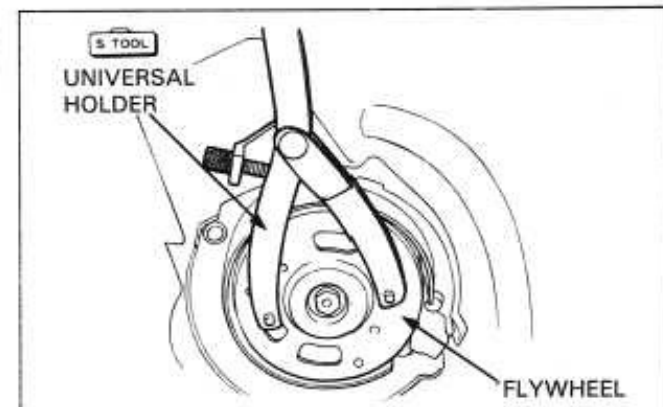

DISASSEMBLY

NOTE

- There are two types of movable drive face; wet type which needs the grease application inside of the face and dry type which doesn't need grease application.

Remove the movable drive face and drive face shaft from the crankshaft.

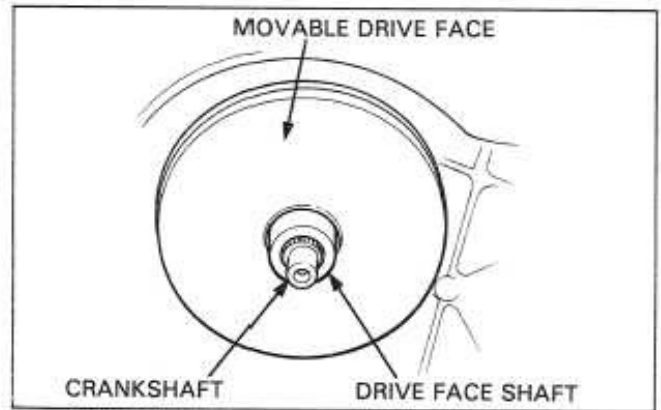

Remove the three bolts attaching the movable drive face seal and remove the seal.

Remove the ramp plate.

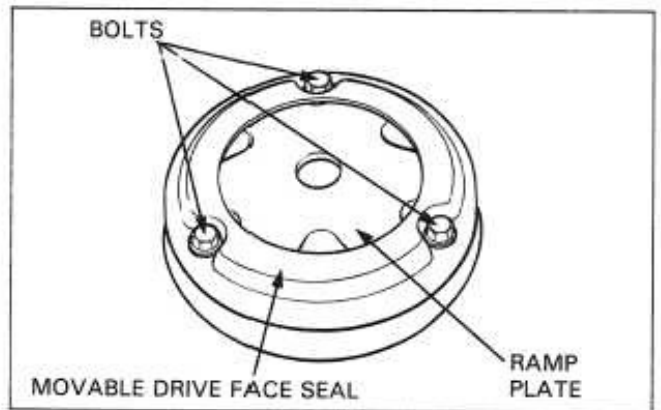

WET TYPE:

Remove the weight rollers and the O-rings from the movable drive face.

DRY TYPE:

Remove the weight rollers from the movable drive face.

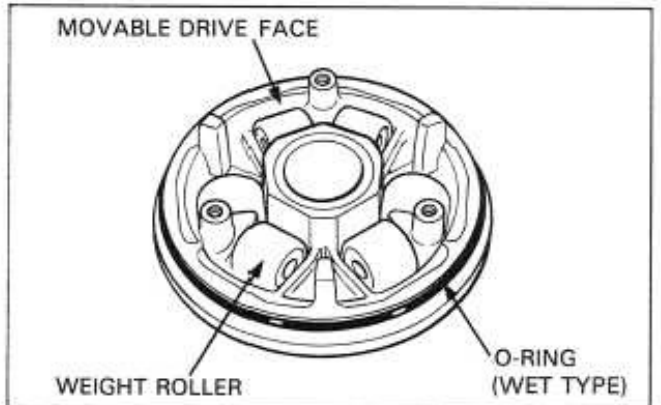

INSPECTION

The weight rollers push on the movable drive pulley face (by centrifugal force); worn or damaged weight rollers will interfere with this force.

Check the rollers for wear or damage and replace as necessary.

Measure the O.D. of each roller, replace if the service limit is exceeded.

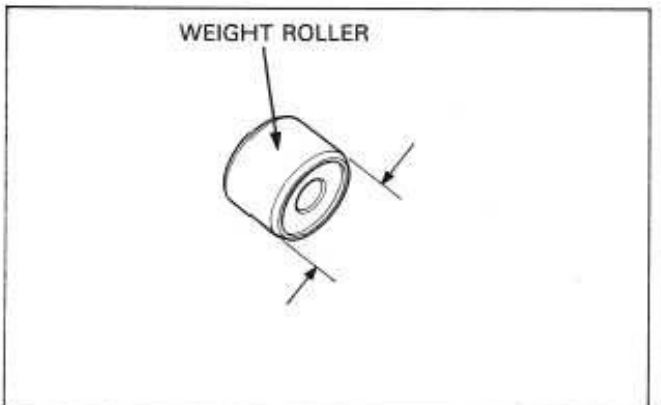

V-MATIC BELT DRIVE SYSTEM

Check the drive face shaft for wear or damage and replace as necessary.

Measure the O.D. of the drive face shaft. Replace the shaft if the service limit is exceeded.

Measure the I.D. of the drive face. Replace it if the service limit is exceeded.

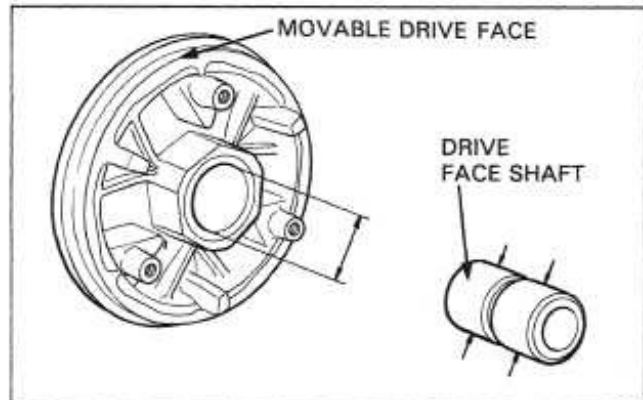

If an dust seal is installed, check it for damage and deterioration. Because defect dust seal causes bad operation of the movable drive face (the dust seal doesn't slide smoothly on the face boss), replace it with the new one.

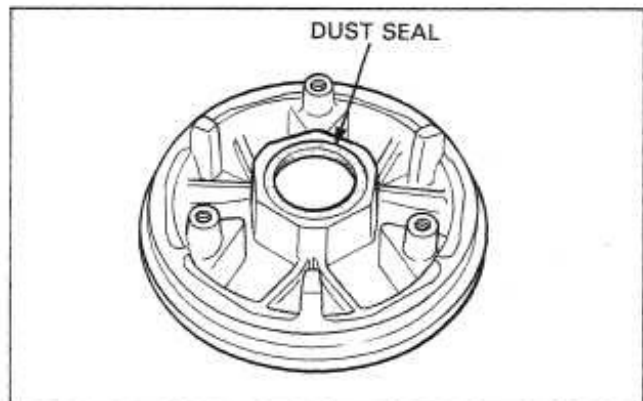

ASSEMBLY/INSTALLATION

WET TYPE:

Pack the inside of the movable drive face with the specified amount of grease, then install the weight rollers.

NOTE

- Use only the specified grease in the specified amount or the clutch operation will be affected.
- Apply the grease equally over the inside of the pulley face.

SPECIFIED GREASE (Lithium Based Grease):

Mitsubishi HD-3

Nippon Sekiyu Lipanox Deluxe 3

Idemitsu Coronex 3

Sta-Lube MP #3141

Bel-Ray Moly Lube 126 EP#0

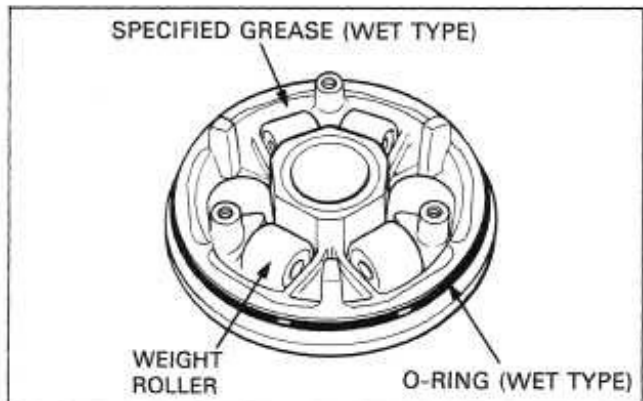

Install the O-ring.

DRY TYPE:

Make sure there is no oil or grease inside of the movable drive face, then install the weight rollers.

Install the ramp plate.

Install the face seal and tighten the bolts to the specified torque.

NOTE

- Take care that the O-ring doesn't come out from its groove, with the wet type.

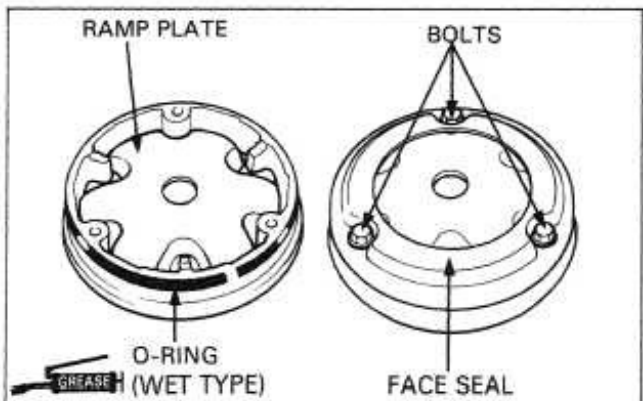

V-MATIC BELT DRIVE SYSTEM

Coat the inside of the drive face shaft with 4–5 g of grease. Install the shaft with the splined hole facing out.

NOTE

- Do not get the grease on the pulley face. Remove any misplaced grease with a degreasing agent.

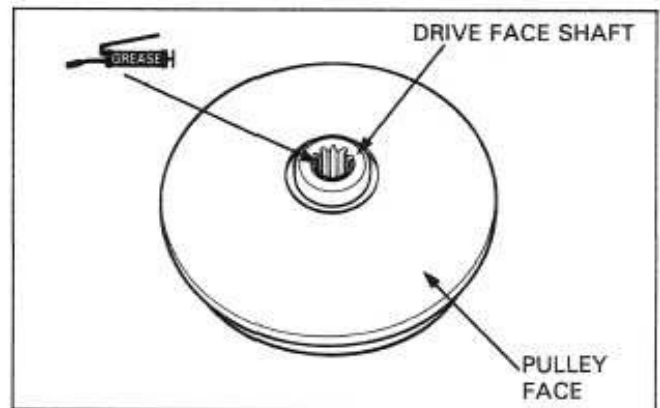

Install the movable face assembly on the crankshaft.

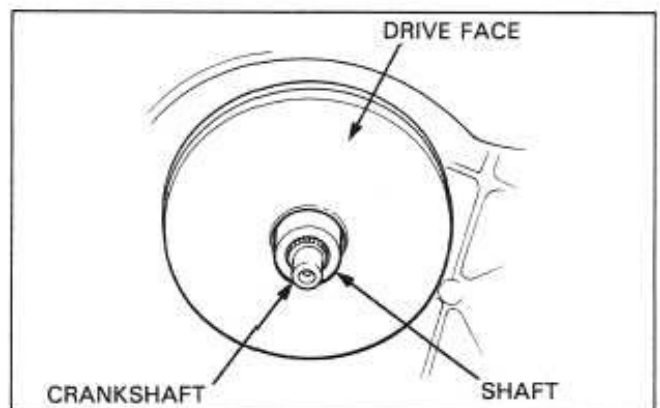

DRIVE PULLEY FACE INSTALLATION

Squeeze the drive belt into the pulley groove and pull the drive belt over the drive face shaft.

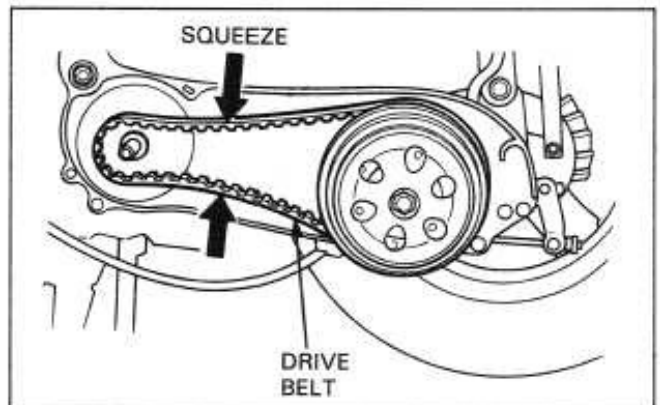

Install the drive pulley face, washer and nut.

NOTE

- Be sure both pulley faces are free of oil and grease.

Hold the drive pulley face using the drive pulley holder and tighten the nut to the specified torque.

 S TOOL

DRIVE PULLEY HOLDER

07923-KM10000

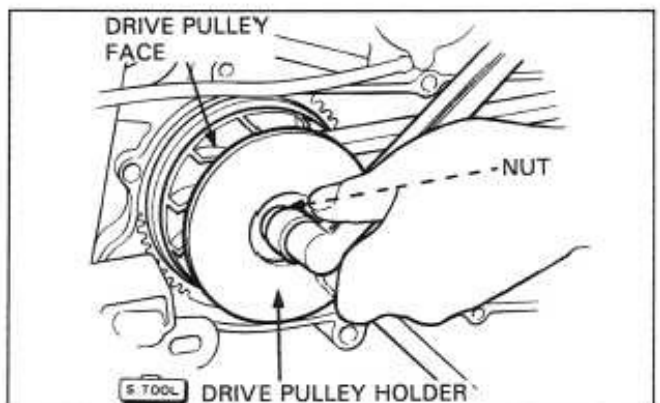

V-MATIC BELT DRIVE SYSTEM

NOTE

- If the pulley holder cannot be used, remove the cooling fan and hold the flywheel with the universal holder.

S TOOL

UNIVERSAL HOLDER

07725-0030000

Install the left crankcase cover (see Model Specific manual).

CLUTCH/DRIVEN PULLEY

DISASSEMBLY

Remove the drive belt and clutch/driven pulley (see page 12-5).

Install a clutch spring compressor on the pulley assembly and tighten the tool to gain access to the nut.

NOTE

- Do not overtighten the compressor.

Hold the clutch spring compressor in a vise as shown and remove the lock nut using the lock nut wrench.

Loosen the clutch spring compressor and disassemble the clutch and spring from the driven pulley.

Remove the seal collar from the driven pulley.

Remove the guide pins and guide pin rollers and the movable driven pulley face.

Remove the O-ring and oil seals from the movable face.

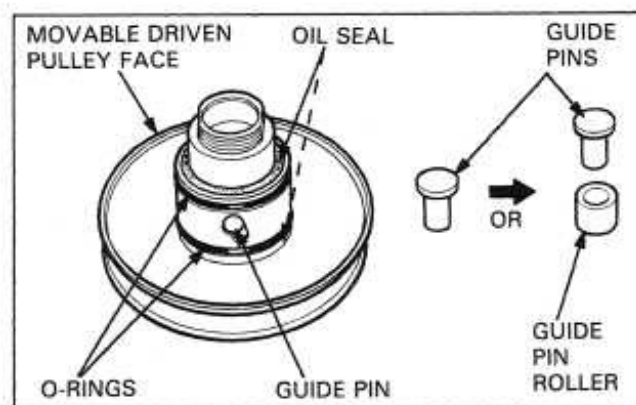
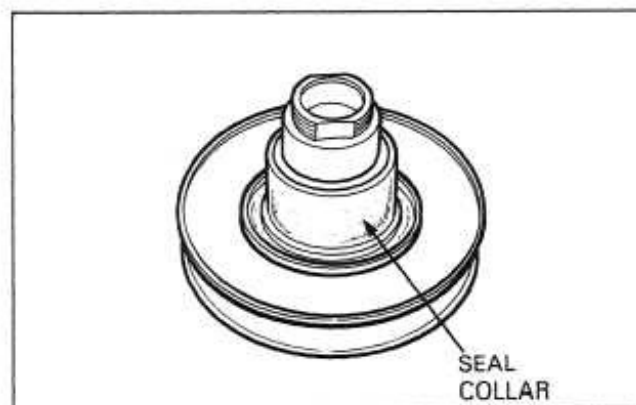
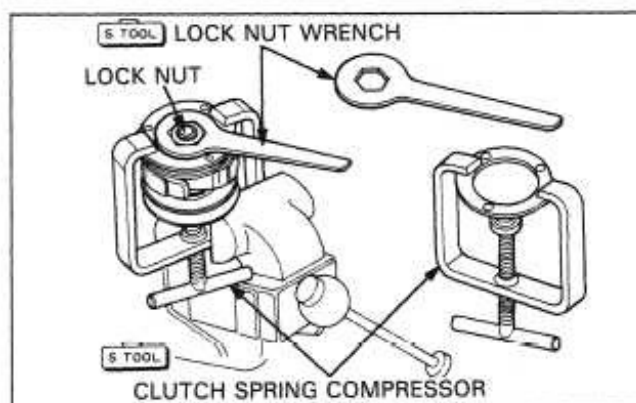
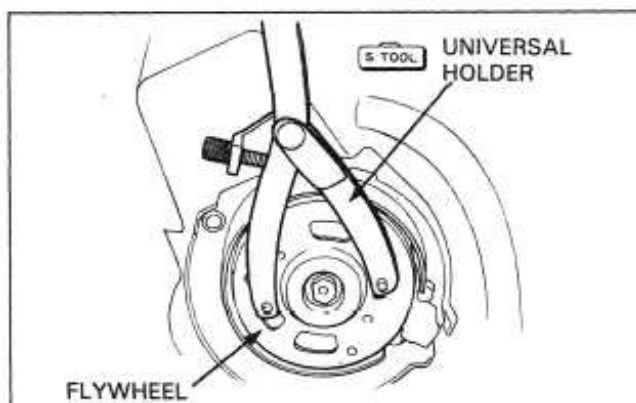

INSPECTION

Clutch Outer

Measure the I.D. at the shoe contact surface of the clutch outer.
 Replace the outer if the service limit is exceeded.

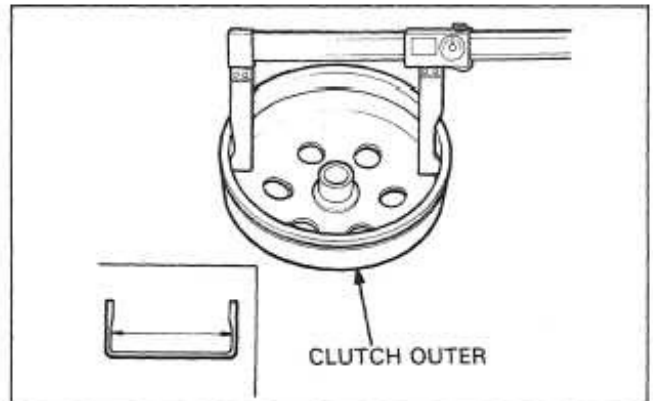

Clutch Shoe

Measure the thickness of each shoe; replace if the service limit is exceeded.

Refer to page 12-12 for clutch shoe replacement.

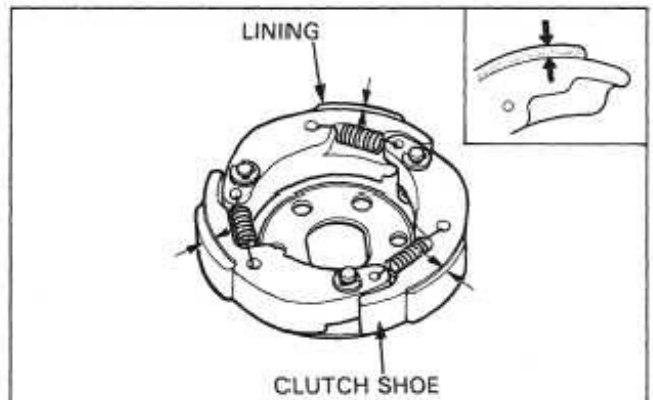

Driven Pulley Spring

Measure the free length of the driven pulley spring and replace if the service limit is exceeded.

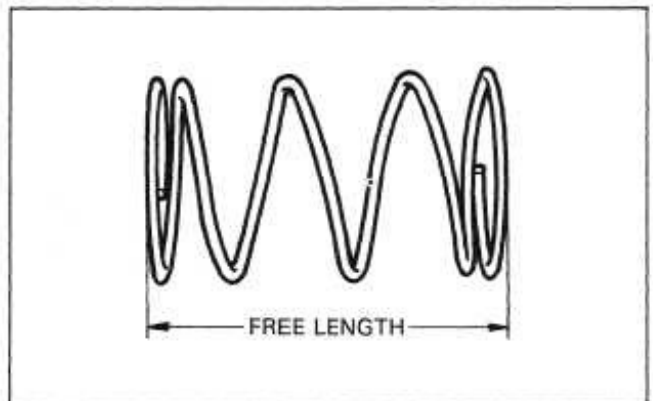

Driven Pulley

Check the following:

- Both faces for damage or excessive wear.
- Guide pin groove for damage or deformation.

Replace damaged or worn parts as necessary.

Measure the O.D. of the driven face and the I.D. of the movable driven face. Replace either part if the service limit is exceeded.

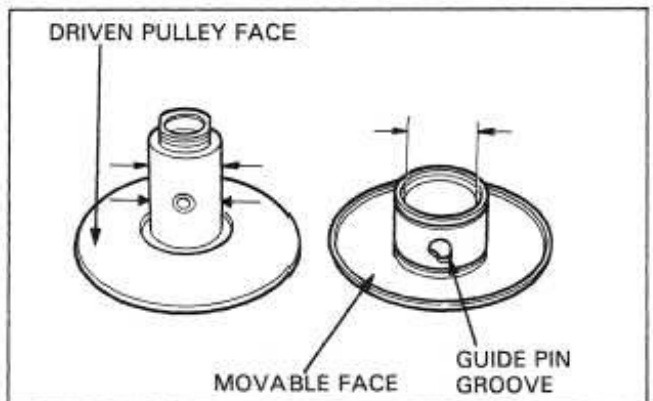

V-MATIC BELT DRIVE SYSTEM

Driven Face Bearing Inspection

Check the inner bearing oil seal (if installed) for damage; replace as necessary.

Check the needle bearing for damage or excessive play and replace as necessary.

Turn the inner race of the outer bearing with your finger. Check that the bearing turns smoothly and quietly, and that the bearing outer race fits securely. Replace the bearing if necessary.

NOTE

- Some models use two ball bearings.

Refer to page 12-13 for bearing replacement.

CLUTCH SHOE REPLACEMENT

Remove the snap rings and washers, then remove the clutch shoes and shoe springs from the drive plate.

NOTE

- Some models use one retainer plate instead of three snap rings.

Check the shoe springs for damage or loss of tension.

Check the damper rubbers for damage or deformation; replace as necessary.

Apply a small amount of grease on the pivot pins.

Install new clutch shoes on the pivot pins and push them into place.

Use a small amount of grease on the pivot pin and keep grease off of the brake shoes. Replace the brake shoes if there is any grease on them.

CAUTION

- Grease or oil damages clutch shoes and can lead to a loss of engaging ability.

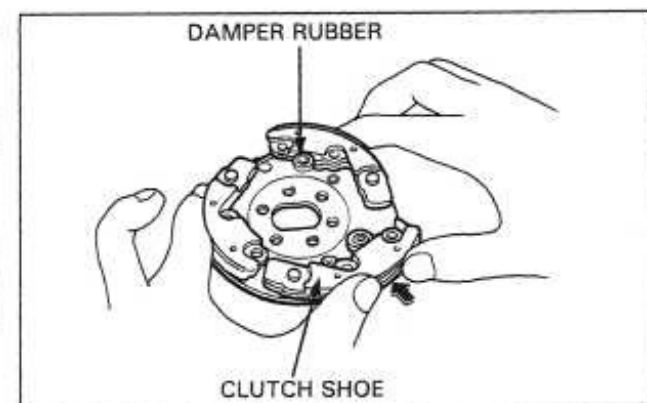
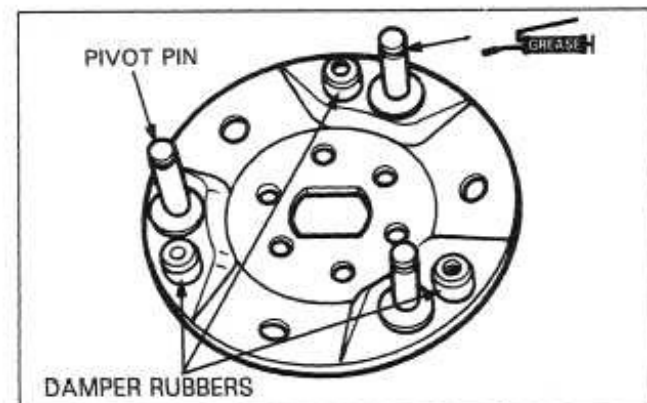
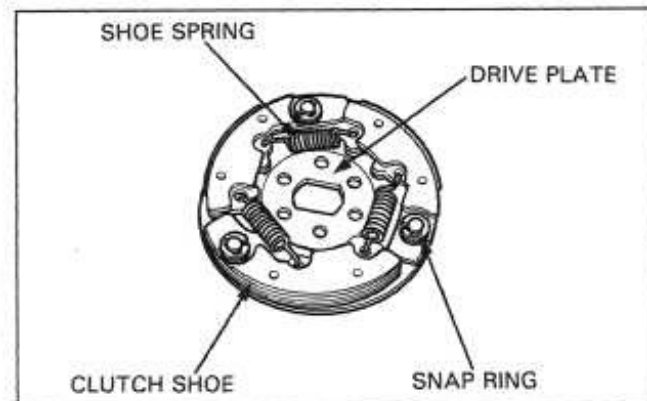
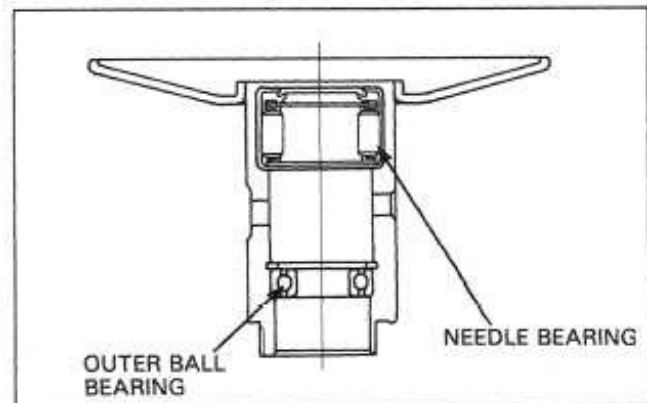

Use pliers to hook the springs to the shoes.



Install the snap rings and washers or retainer plate onto the pivot pins.

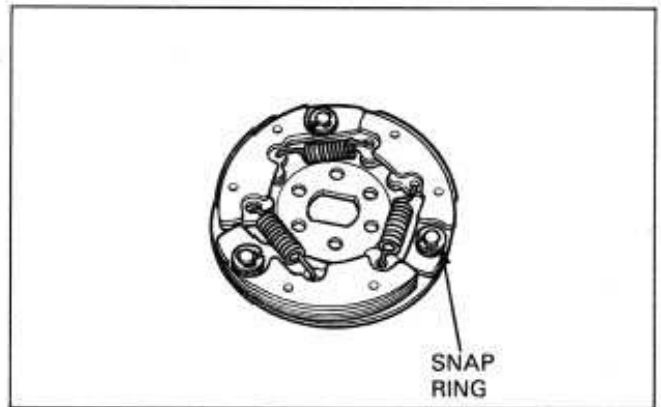

DRIVEN FACE BEARING REPLACEMENT

Remove the inner bearing.

NOTE

- If the driven face has an oil seal at inner bearing side, remove the oil seal first.
- If a ball bearing is used on the inside, remove the snap ring first then remove the bearing.

Remove the snap ring then drive out the outer bearing toward the inner bearing side.

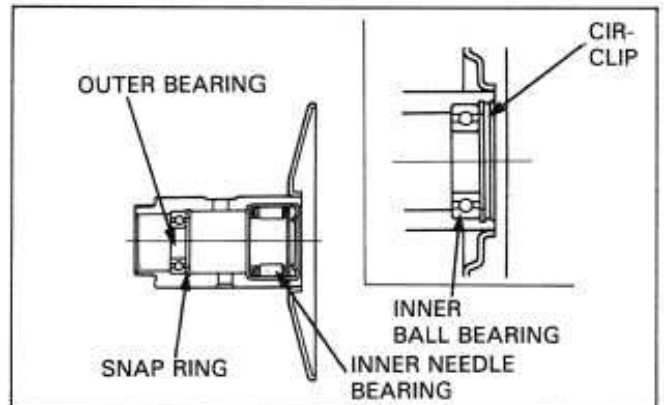

Drive a new outer bearing into place with the sealed end toward the outside.
Install the snap ring securely.

Apply the specified amount of specified grease as shown.

SPECIFIED GREASE (Lithium Based Grease):

- Mitsubishi HD-3
- Nippon Sekiyu Lipanox Deluxe 3
- Idemitsu Coronex 3
- Sta-Lube MP #3141
- Bel-Ray Moly Lube 126 EP#0

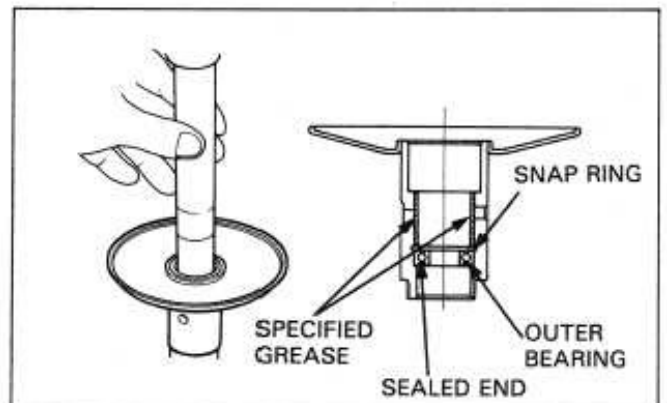

V-MATIC BELT DRIVE SYSTEM

Install in a new inner bearing.

NOTE

- Install the bearing with the sealed side facing out.
- Install the needle bearing using a hydraulic press. Install the ball bearing by driving it in or using a hydraulic press.

Install the snap ring into the groove in the driven face.

Install a new oil seal with the lip toward the bearing (if required).

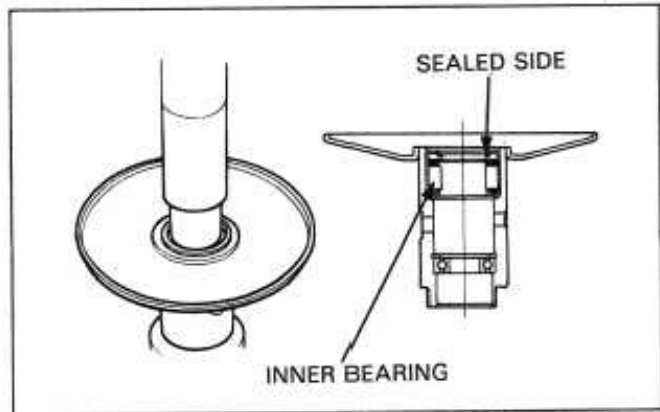

CLUTCH/DRIVEN PULLEY ASSEMBLY

Install new oil seals and O-rings on the movable driven pulley face.

Lubricate the inside of the movable face with the specified amount of grease.

SPECIFIED GREASE (Lithium Based Grease):

- Mitsubishi HD-3
- Nippon Sekiyu Lipanox Deluxe 3
- Idemitsu Coronex 3
- Sta-Lube MP #3141
- Bel-Ray Moly Lube 126 EP#0

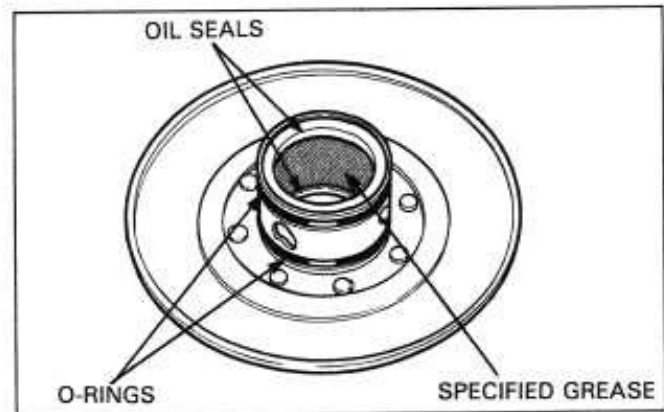

Install the movable face on the driven pulley face.

Install the guide pins, or guide pins and guide pin rollers.

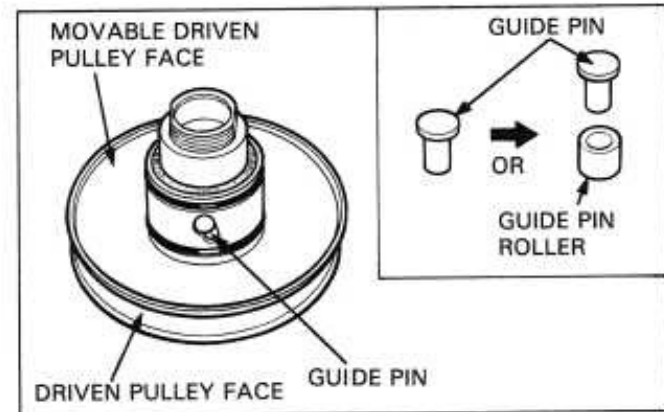

Install the seal collar.

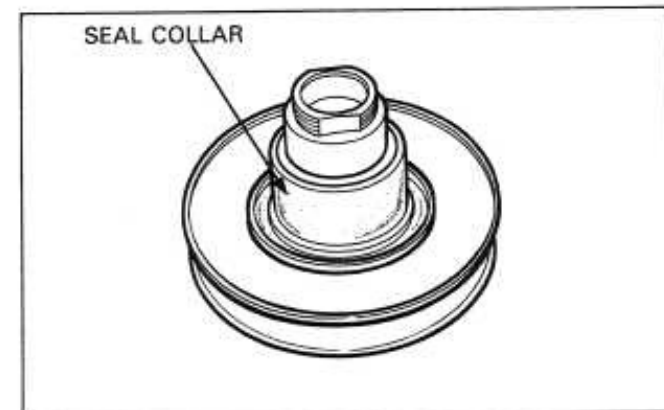

V-MATIC BELT DRIVE SYSTEM

Assemble the driven pulley, spring and clutch in the clutch spring compressor. Compress the assembly by turning the tool handle until the lock nut can be installed.

Clamp the clutch spring compressor in a vise and tighten the lock nut to the specified torque using the lock nut wrench. Remove the spring compressor.

Install the clutch/driven pulley and drive belt onto the drive shaft (see page 12-5).

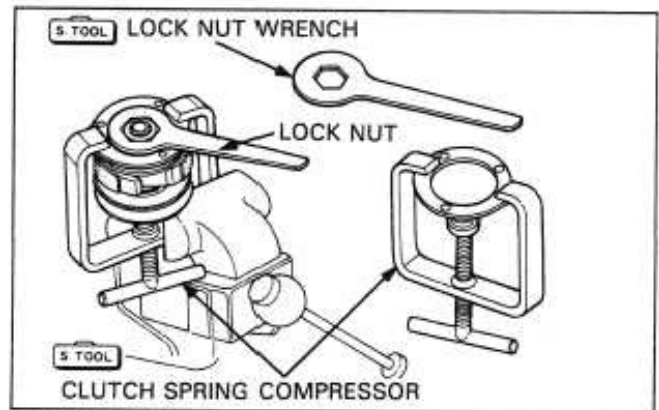

MEMO

13. TRANSMISSION

SERVICE INFORMATION	13-1	TRANSMISSION DISASSEMBLY	13-6
TROUBLESHOOTING	13-1	TRANSMISSION INSPECTION	13-6
SYSTEM DESCRIPTION	13-2	TRANSMISSION ASSEMBLY	13-7

SERVICE INFORMATION

- Refer to the Model Specific manual for proper servicing information on the particular model in question.

TROUBLESHOOTING

Hard to shift

- Improper clutch operation
- Incorrect engine oil weight
- Incorrect clutch adjustment
- Bent shift forks
- Bent fork shaft
- Bent fork claw
- Damaged shift drum cam grooves
- Bent shift spindle

Transmission jumps out of gear

- Worn gear dogs or slots
- Bent fork shaft
- Broken shift drum stopper
- Worn or bent shift forks
- Broken shift linkage return spring

TRANSMISSION

SYSTEM DESCRIPTION

GEARSHIFT MECHANISM

CONVENTIONAL TYPE

The gearshift mechanism consists of three gearshift forks, a gearshift drum, a gearshift arm, a shift drum stopper and a gearshift positive stopper. When the gearshift pedal is depressed the gearshift spindle rotates, causing the gearshift arm to rotate the shift drum. When the shift drum rotates, the shift forks move sideways due to the cam action of the groove cut in the shift drum body.

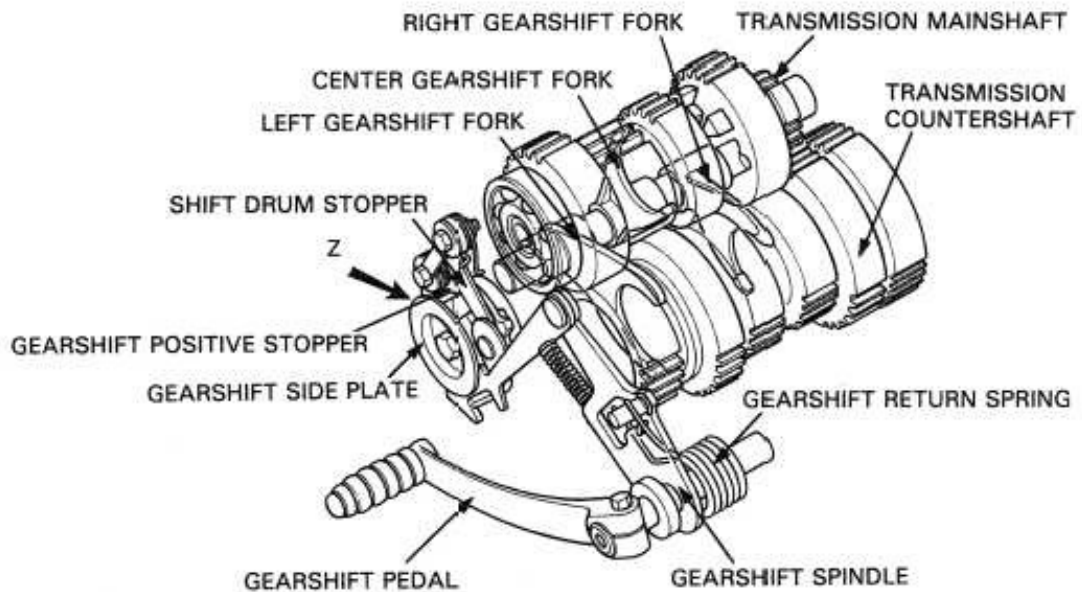
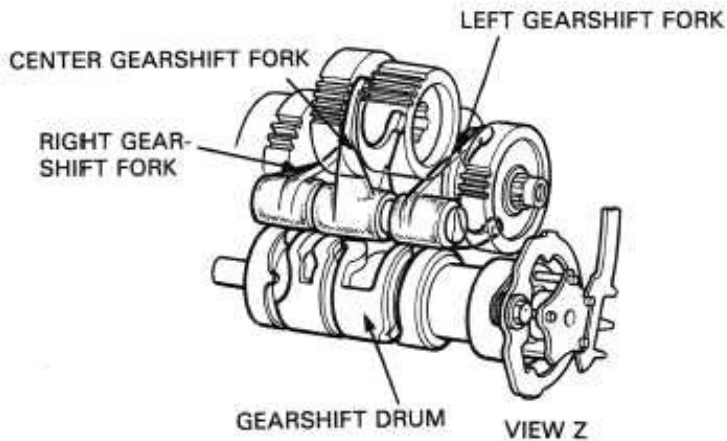

PLANETARY GEAR TYPE

This system is comprised of a shift spindle assembly, guide plates, drum shifter, and two stopper assemblies.

The shift spindle assembly is comprised of the shift spindle, and the three planetary gears.

The shift spindle assembly, plus the guide plates, transmit the gear shifter movement to the sun gear on the drum shifter. As the drum shifter turns, one of its pawls will engage a detent in the shift drum, turning the drum.

Turning the drum causes the shift forks to move by the same cam action as with the conventional type shift mechanism.

The two stopper assemblies locate the shift drum at the proper gear and neutral positions.

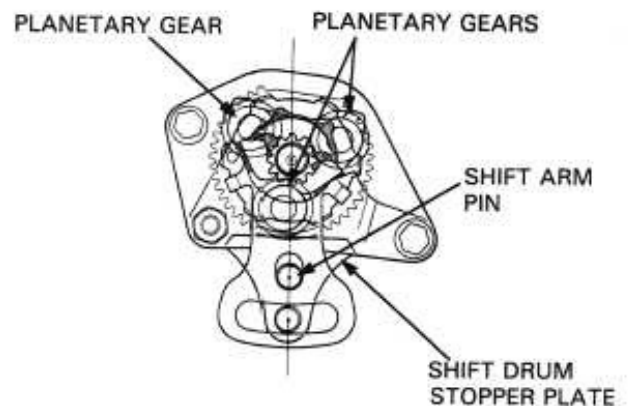
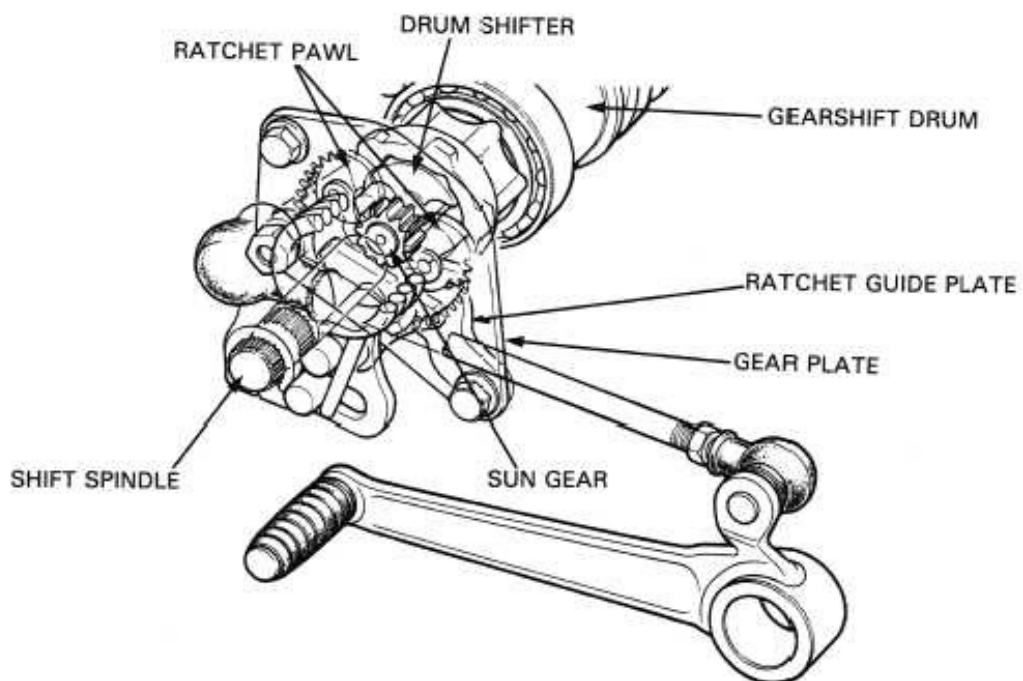

TRANSMISSION

Shift Start

Pushing down on the shift pedal turns the spindle counterclockwise. Because the gear plate is fixed, the planetary gears turn clockwise, turning the drum shifter counterclockwise.

As the drum shifter turns counterclockwise, the right pawl engages the detent in the shift drum, while the left pawl is pushed out of the way into the shifter by the guide plate. With the pawl engaged, the drum shifter turns the shift drum, moving the shift forks into place.

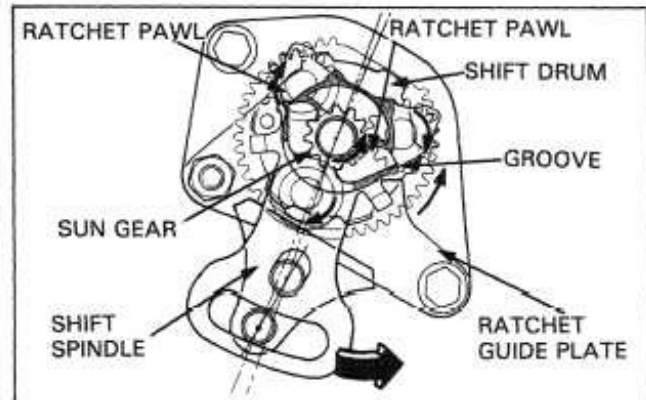

Shift Finish

To prevent the drum from rotating too far, a shift drum stopper plate is used. The shift drum stopper plate rotates on an eccentric pivot moved by the spindle assembly.

As the spindle reaches the end of its travel, one leg of the stopper plate is moved up to contact a positive stop on the shift drum. At the same time the spindle assembly is prevented from moving too far by the shift arm stopper pin.

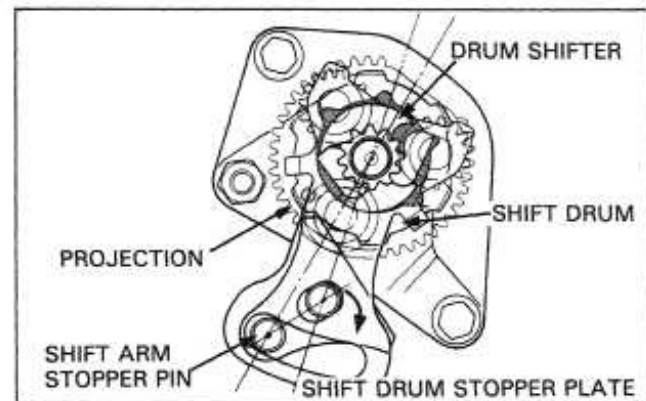

Shift Return

When the shift pedal is released, the shift return spring brings the spindle assembly back to the centered position.

At this time, the drum shifter rotates and the ratchet feature allows the right pawl to disengage from the shift drum. As the drum shifter rotates, the drum stopper arm prevents the shift drum from moving.

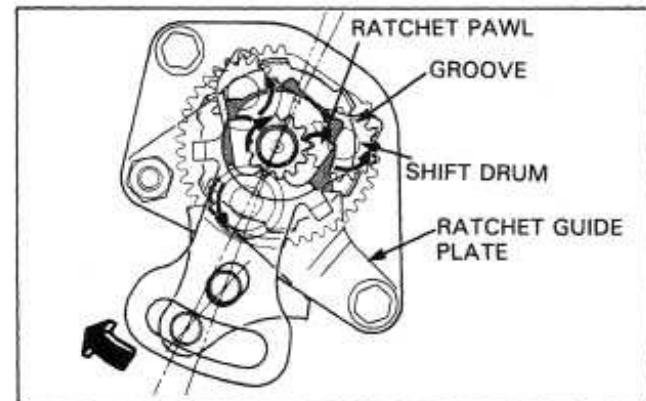

CONSTANT MESH TRANSMISSION

The constant mesh transmission consists of the following components:

- The mainshaft, with its fixed and sliding gears.
- The countershaft, with its fixed and sliding gears.
- The shift forks.
- The shift drum.

Power is transmitted through the clutch to the mainshaft.

From the mainshaft, power may be transmitted through several gear sets to the countershaft.

M1 through M5 are the gears on the mainshaft and C1 through C5 are the countershaft gears.

The gear sets are comprised of opposing gears, one gear on each shaft.

The illustration on the right shows the gear sets, pairing the mainshaft number with the countershaft number (M1/C1, M2/C2, etc.).

Selection of the proper gear set is done by moving a sliding gear into contact with the gear set desired.

Connection of the sliding gear and the gear set is done using dogs and dog holes on the sides of the gears.

In the illustration, gears M3, C4, and C5 are the sliding gears.

The sliding gears are moved by shift forks which ride on the shift drum. Cam grooves cut in the shift drum move the shift forks as the drum rotates.

Rotation of the shift drum is done by working the gearshift pedal.

The relative positions of the transmission at the respective changing position are shown below.

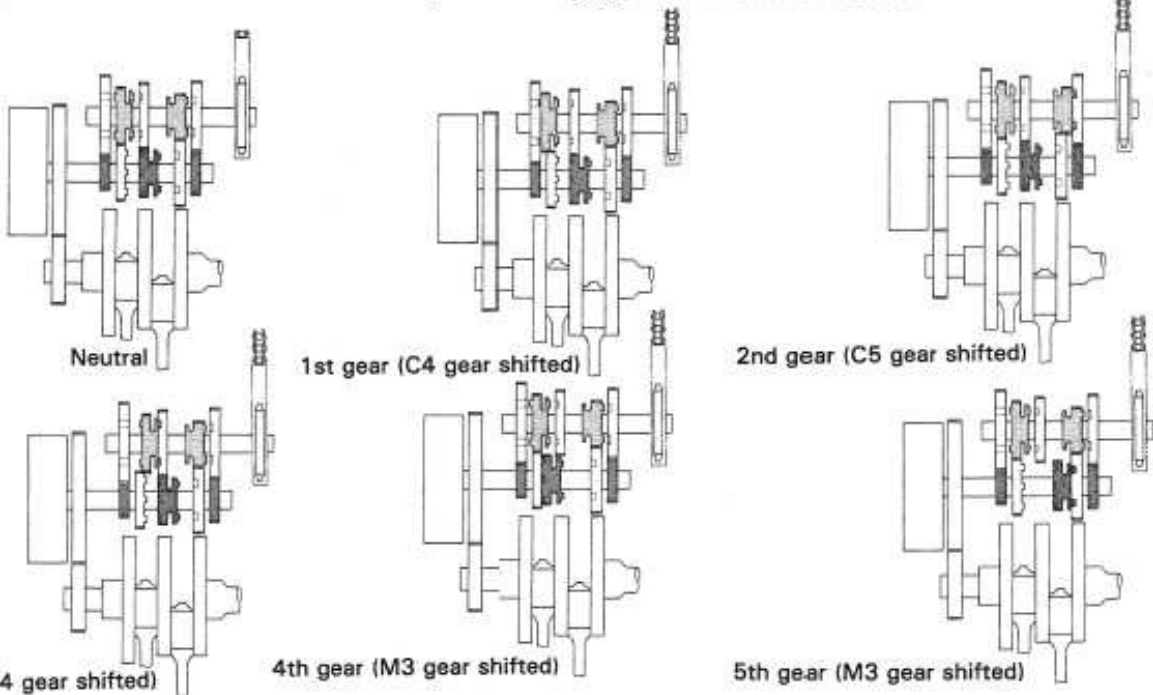
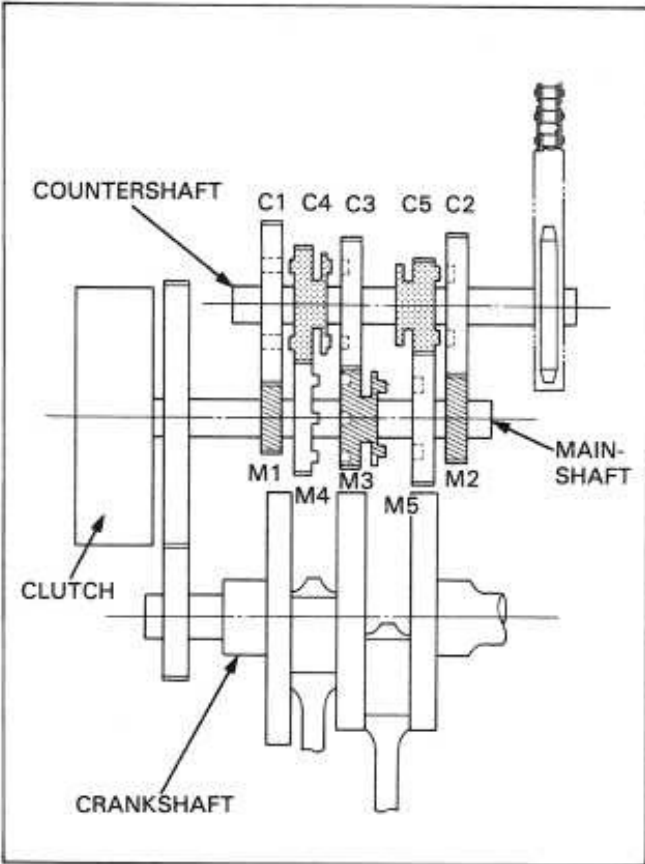

TRANSMISSION

TRANSMISSION DISASSEMBLY

NOTE

- Keep track of the disassembled parts (gears, bushings, washers, and snap rings) by stacking them on a tool or slipping them onto a piece of wire.
- Do not expand the snap ring more than necessary for removal. To remove a snap ring, expand the snap ring and pull it off using the gear behind it.

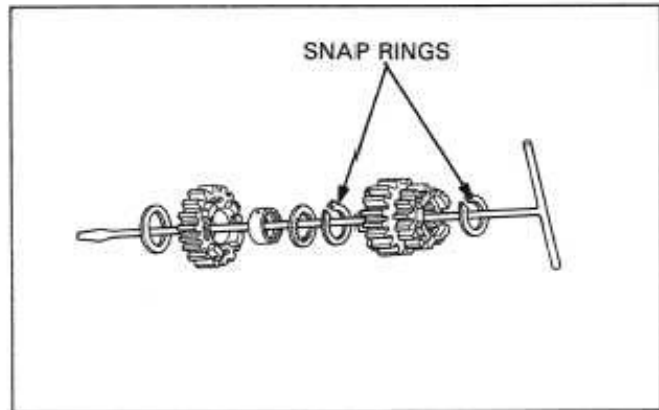

TRANSMISSION INSPECTION

Check the following:

Gears:

- Inspect teeth—for damage or excessive wear.
- Inspect dogs and dog holes—for damage excessive wear.
- Measure the gear I.D. (except splined holes and holes with needle bearings).

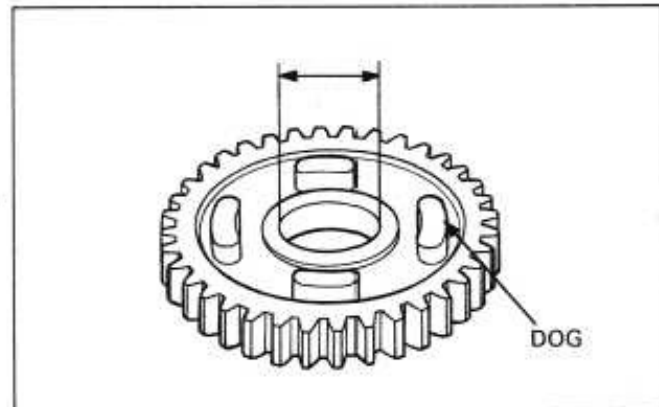

Bushings:

- Inspect for wear or damage.
- Measure the I.D. and O.D.
- Calculate the gear-to-bushing and bushing-to-shaft clearances.

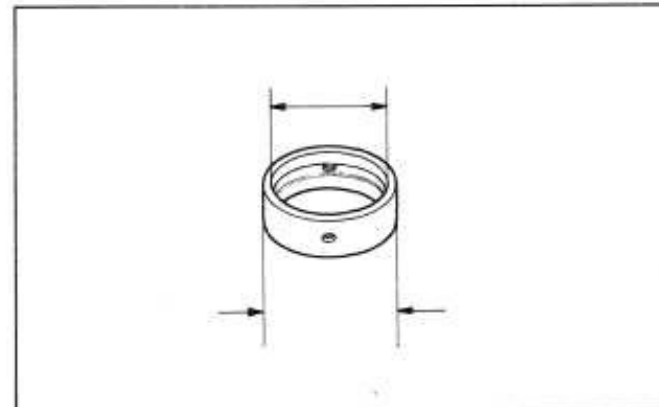

Mainshaft, Countershaft

- Inspect spline groove and sliding surface for abnormal wear or damage.
- Measure O.D. at the gear sliding areas.
- Calculate the gear-to-shaft and shaft-to-bushing clearances.

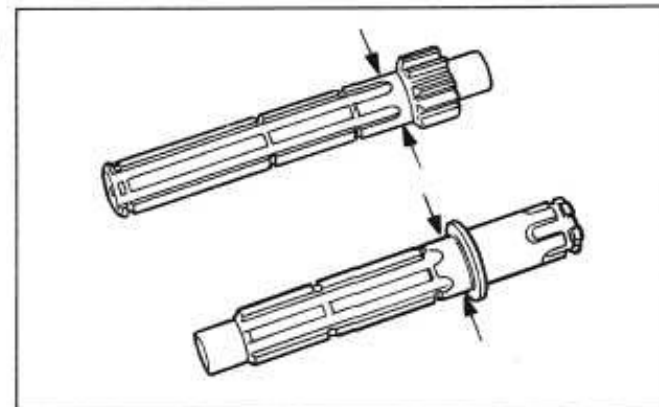

Shift Drum

- The guide groove for abnormal wear or damage.
- The bearing for excessive play or damage (if required).

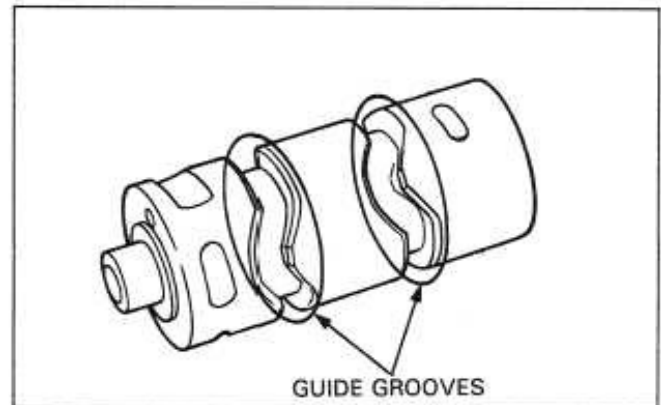

Shift Fork

- For deformation or abnormal wear.
- Measure the fork claw thickness.
- Measure the I.D. of the shift fork.

NOTE

- Some fork claws are measured at A and C (claw ends). Others are measured at B (the center).

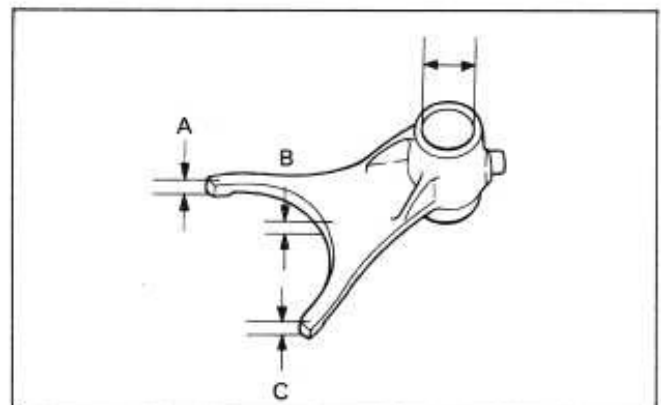

Shift Fork Shaft

- For damage and straightness.
- Measure the O.D. at the shift fork areas.

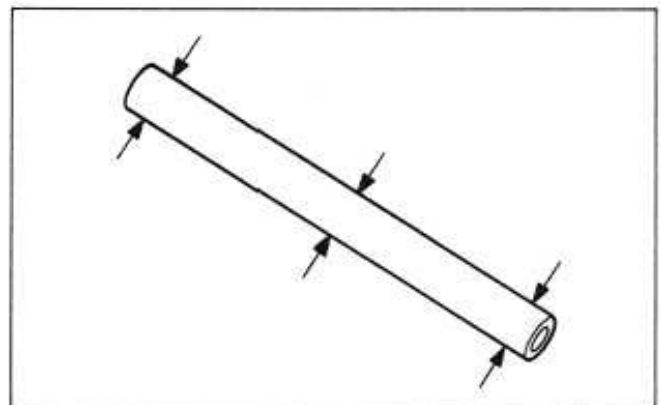

TRANSMISSION ASSEMBLY

Clean all parts in solvent.

Apply molybdenum disulfide grease to all sliding surfaces of the mainshaft, countershaft and bushings to ensure initial lubrication.

Reassemble all parts into their original positions.

NOTE

- Always install the thrust washers with the chamfered (rolled) edge facing away from the thrust load.
- After installing a snap ring, slightly open the ring and rotate it in its groove to be sure it is fully seated.
- Do not use worn snap rings which could easily spin in the groove. It would be too loose to properly seat in the groove. Align the gap in the snap ring with the groove of the spline.

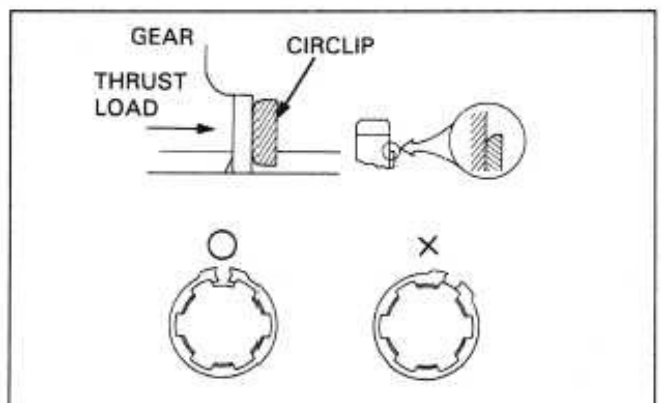

TRANSMISSION

Install the lock washer by aligning its tabs with the grooves of the spline washer.
Do not forget to install the thrust washer at the end of the mainshaft and countershaft.

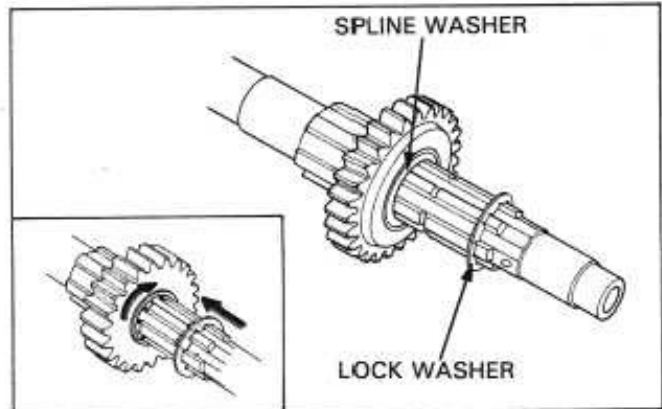

Align oil hole in the bushing or gear with shaft oil hole.

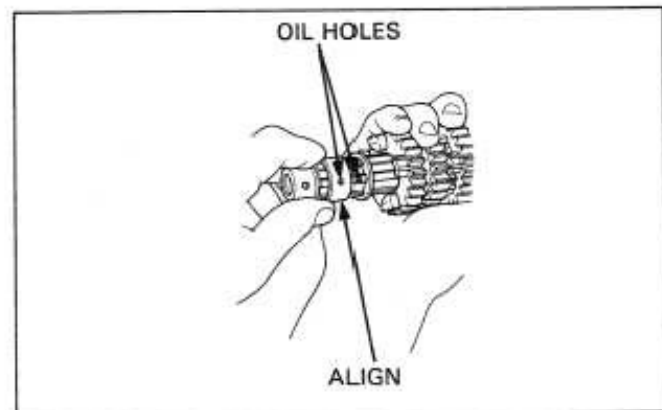

Install the shift forks in the correct positions according to the location mark on each fork.

- "L" mark: Left side of the crankcase
- "C" mark: Center of the crankcase
- "R" mark: Right side of the crankcase

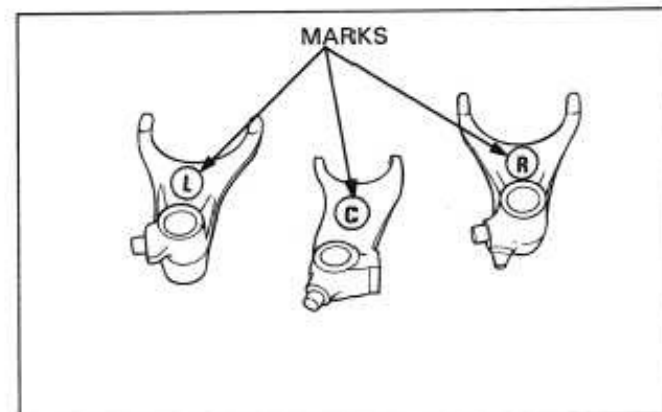

Turn the mainshaft or countershaft to ensure that the gears turn smoothly after reassembly.

Lubricate gears with clean (recommended) engine oil while turning the shaft.

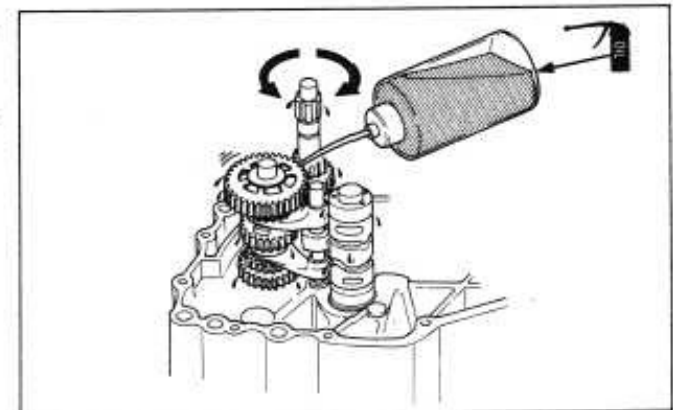

14. CRANKCASE/CRANKSHAFT

SERVICE INFORMATION	14-1	CRANKSHAFT MAIN BEARING	14-3
TROUBLESHOOTING	14-1	CONNECTING ROD BEARINGS	14-8
SYSTEM DESCRIPTIONS	14-2	CONNECTING ROD	14-10
CRANKSHAFT INSPECTION	14-3		

SERVICE INFORMATION

- Refer to the Model Specific manual for removal/installation of the crankshaft.
- Mark and store the bearing inserts to be sure of their correct locations for reassembly. If the inserts are improperly installed they will block the oil holes, causing insufficient lubrication and eventual engine seizure.

TROUBLESHOOTING

Excessive noise

- Worn connecting rod big end bearing
- Bent connecting rod
- Worn crankshaft main bearing

CRANKCASE/CRANKSHAFT

SYSTEM DESCRIPTIONS

The crankshaft changes the reciprocating action of the piston and connecting rod into rotary motion, so the energy can be transmitted to the clutch and transmission.

It is necessary that the reciprocating and rotating components are properly balanced to produce a smooth running engine.

Stresses on the components increase proportional with an increase in rpm's.

Because of this increased stress, it is critical that the balance is maintained when components are replaced.

There are two types of crankshafts; the assembly type in which the right and left crankshafts are assembled with the aid of a crank pin, and the single unit type, in which a unibody crankshaft is employed. In the case of the former, caution should be exercised when handling it, because if it is dropped, the crank pin will be knocked out of alignment.

The unit type employs plain-type main bearings. While the crankshaft is designed to rest directly on the metal bearing material, strictly speaking, the crankshaft and metals are lubricated on their surfaces by an oil film.

Consequently, scratches, burrs or dust on the bearing surface spoils the oil film, leading to bearing seizure.

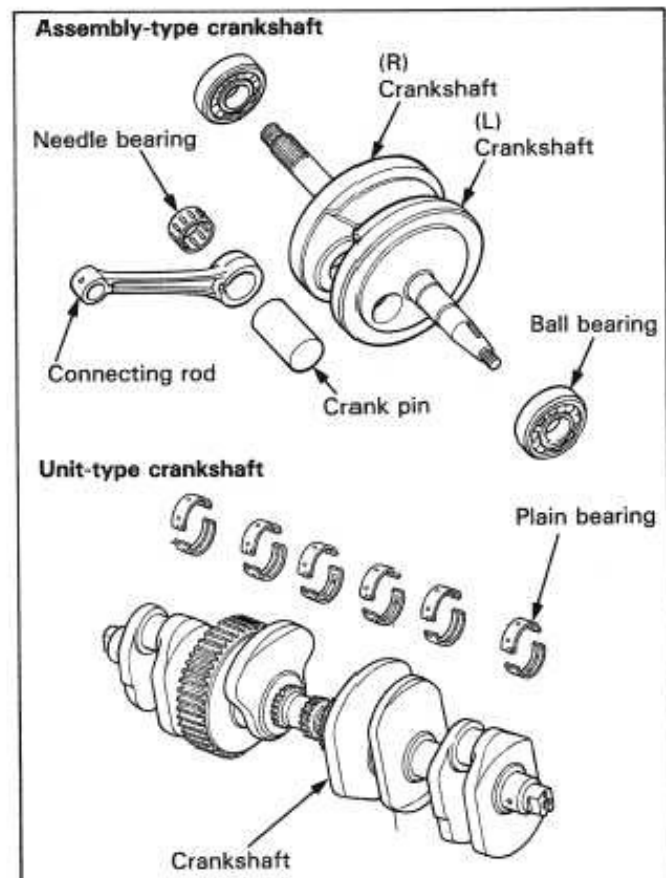
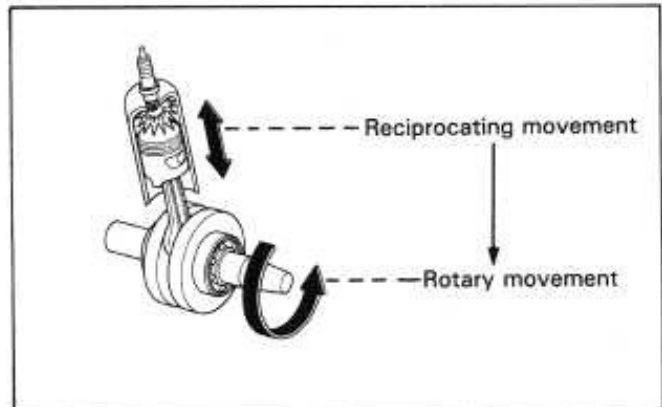

CRANKSHAFT INSPECTION

SIDE CLEARANCE

Measure the side clearance by inserting the feeler gauge between the crankshaft and connecting rod big end as shown.

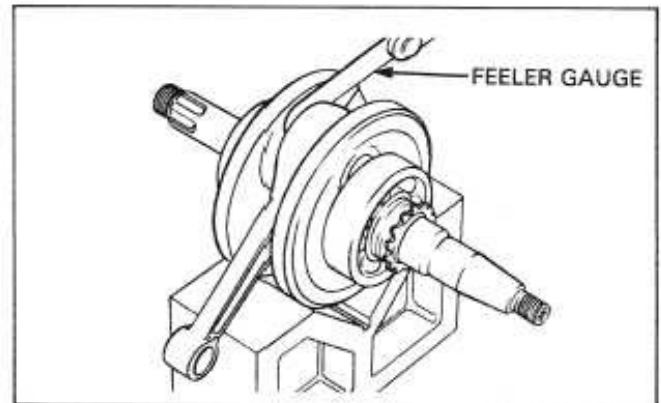

RADIAL CLEARANCE (ASSEMBLY-TYPE CRANKSHAFT ONLY)

Measure the side clearance at the connecting rod big end with a feeler gauge. Replace the crankshaft if the service limit is exceeded.

Measure the connecting rod radial clearance in both X and Y directions.

Replace the crankshaft if the service limit is exceeded.

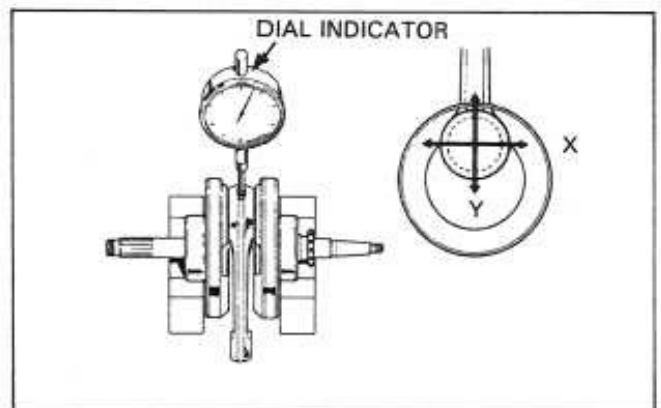

Measure the crankshaft runout using dial indicators.

NOTE

- The single unit crankshaft uses the plain bearings at the main journal. Excessive runout can cause engine seizure.
- Refer to the Model Specific manual for measuring and supporting points.

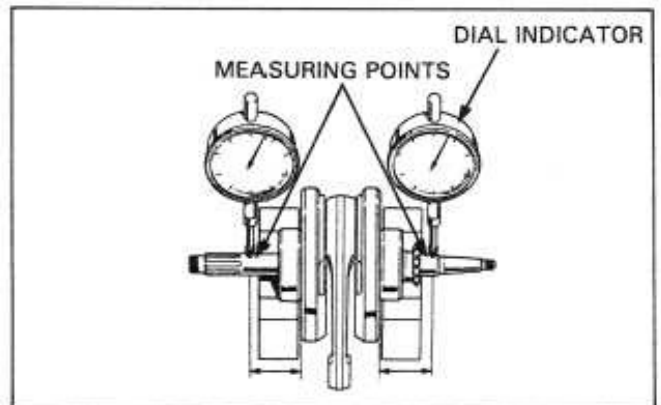

CRANKSHAFT MAIN BEARING

OIL CLEARANCE INSPECTION

NOTE

- Main bearings may be either two-piece or one-piece bushing types.

Check the bearing inserts for unusual wear, damage or peeling and replace as necessary.

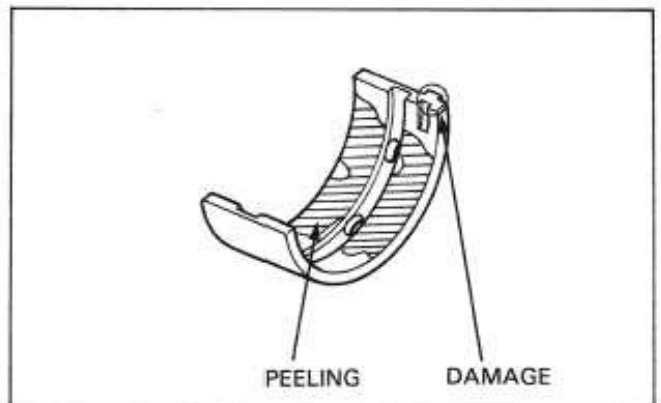

CRANKCASE/CRANKSHAFT

Two-Piece Type:

Wipe all oil from the bearing inserts and journals.

Reinstall the upper crankcase's main bearing inserts, then carefully lower the crankshaft in place.

Put a piece of plastiguage on each journal.

NOTE

- Do not put the plastiguage over the oil holes.
- Do not rotate the crankshaft during the inspection.

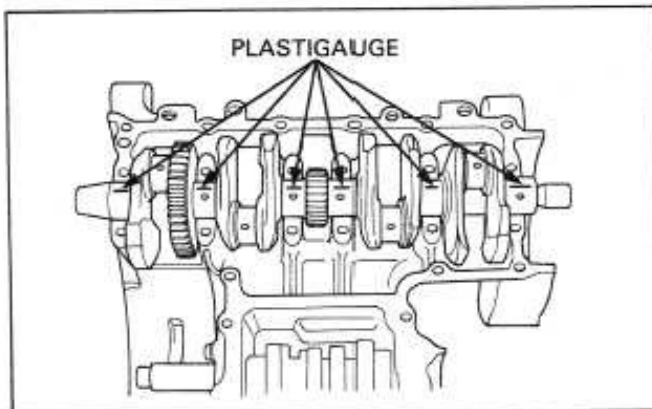

Install the main bearing inserts on the correct journals in the lower crankcase, then assemble and tighten the bolts evenly in 2 or 3 steps to the specified torque.

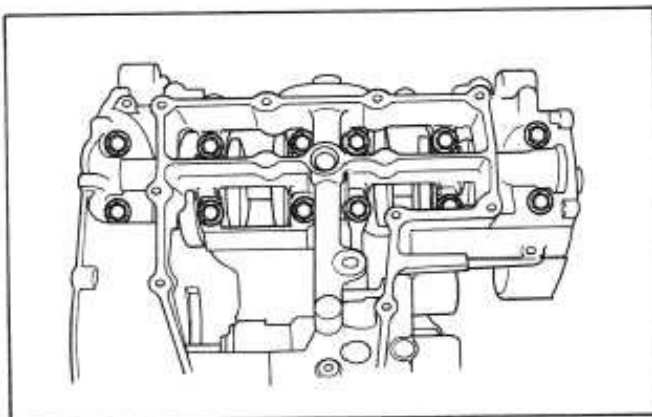

Remove the lower crankcase and measure the compressed plastiguage on each journal.

If the clearance is beyond the service limit, select the correct replacement bearings.

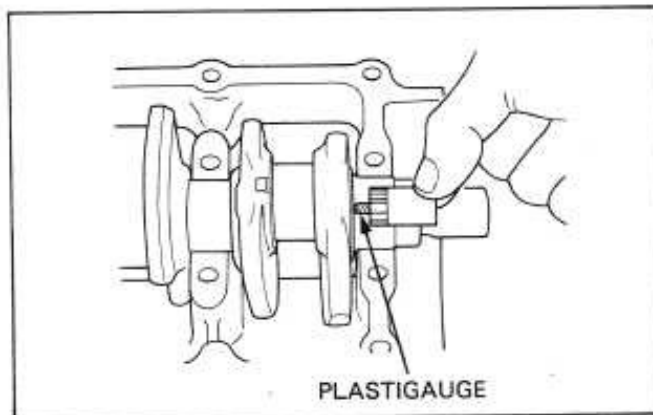

One-piece Type

Wipe all oil from the bearing and the crankshaft journals.

Measure and record the crankshaft main journal O.D.

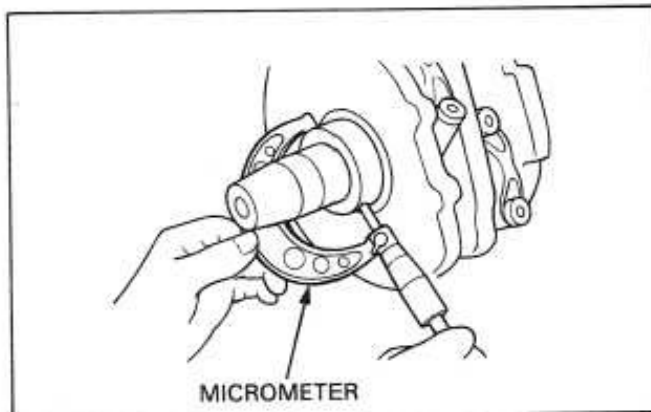

Measure and record the main bearing I.D.

Calculate the oil clearance by subtracting the journal O.D. from bearing I.D. Replace the bearing if the service limit is exceeded.

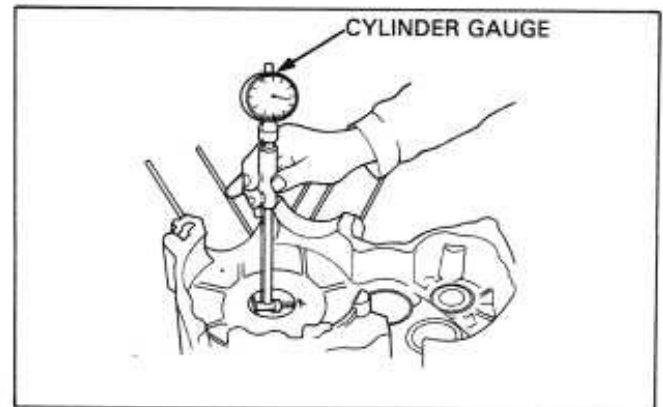

MAIN BEARING SELECTION

Two-piece Type:

Record the crankcase I.D. code letters.

NOTE

- Letters (A, B or C) on the upper crankcase are the codes for the main journal I.D.s from left to right.

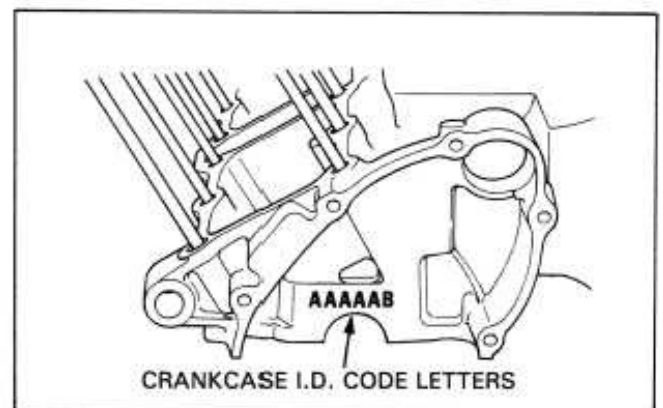

Record the corresponding main journal O.D. code numbers (or measure the main journal O.D.).

NOTE

- Numbers (1, 2 or 3) on each crank weight are the codes for the main journal O.D.s from left to right.

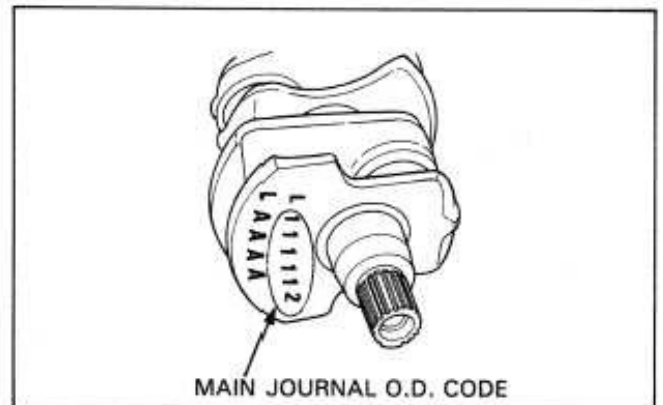

Cross reference the case and journal codes to determine the replacement bearing color code.

Example:

- I.D. code on the crankcase: **A**
- O.D. code on the crankshaft: **1**
- Bearing color code: **Pink**

		CRANKCASE I.D. CODE		
		A	B	C
MAIN JOURNAL O.D. CODE	1	Pink	Yellow	Green
	2	Yellow	Green	Brown
	3	Green	Brown	Black

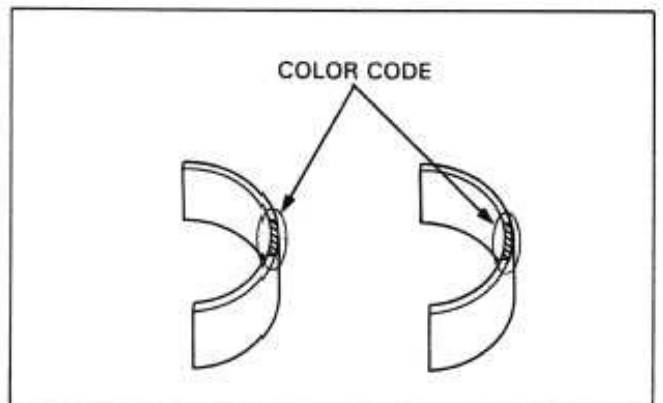

CRANKCASE/CRANKSHAFT

One-piece Type

NOTE

- Some bearings cannot be replaced. Refer to the Model Specific manual for complete information.

Press the old bearing out of the crankcase (page 11-7).

Record the I.D. code letter (A, B or C), or measure the crankcase I.D. after the bearing has been removed.

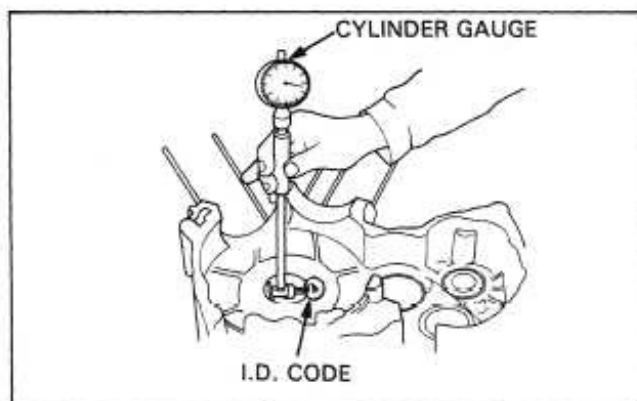

Record the main journal O.D. code number (1, 2 or 3).

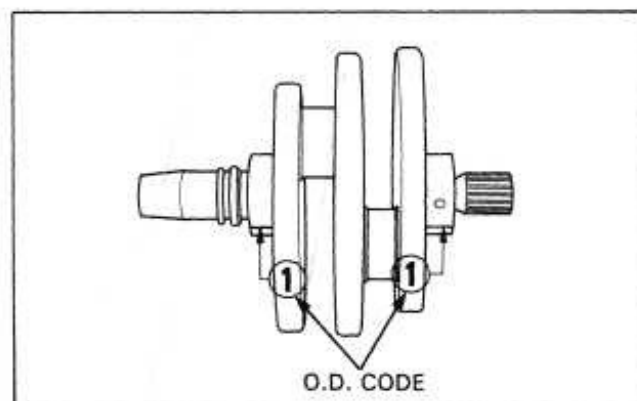

Cross-reference the case and journal codes to determine the replacement bearing color code.

Example:

I.D. code on the crankcase: A
 O.D. code on the crankshaft: 1
 Bearing code: Brown

		CRANKCASE I.D. CODE	
		A	B
MAIN JOURNAL O.D. CODE	1	Brown	Black
	2	Black	Blue

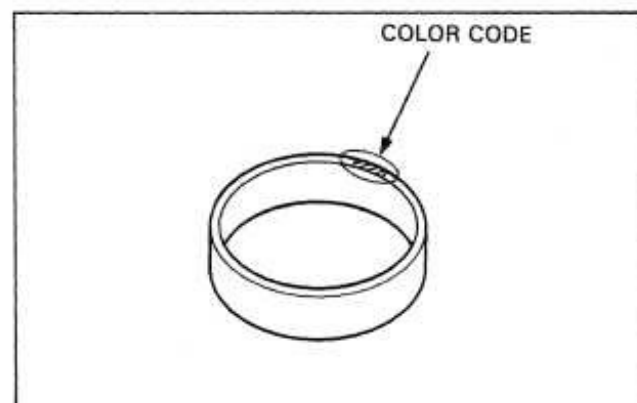

REMOVAL

Two-piece Type

Carefully remove the bearing inserts from the crankcase.

Wipe all oil from the insert seating areas.

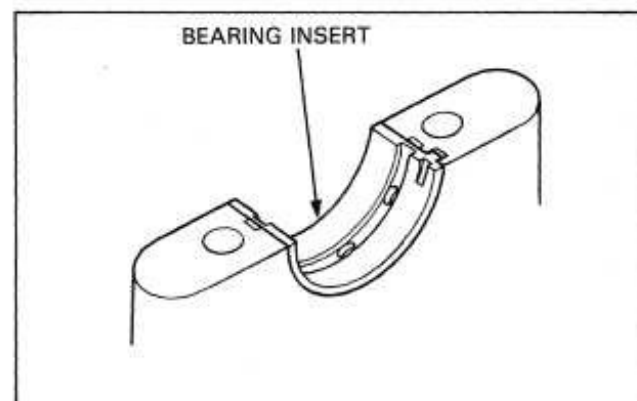

One-piece Type:

Press out the main bearing using the special tool and hydraulic press.

CAUTION

- When removing bearings, always use a hydraulic press and bearing removal tool to prevent crankcase damage.

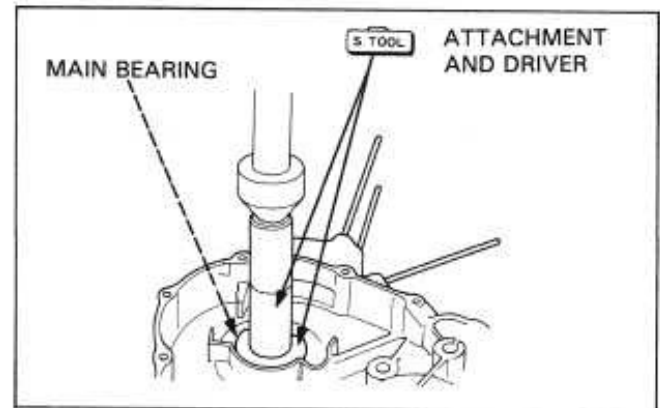

MAIN BEARING INSTALLATION

Two-piece Type:

Install the main bearings into the crankcase.

The bearing tabs should be aligned with the grooves in the case and caps.

Apply molybdenum disulfide solution to the upper and lower main bearings.

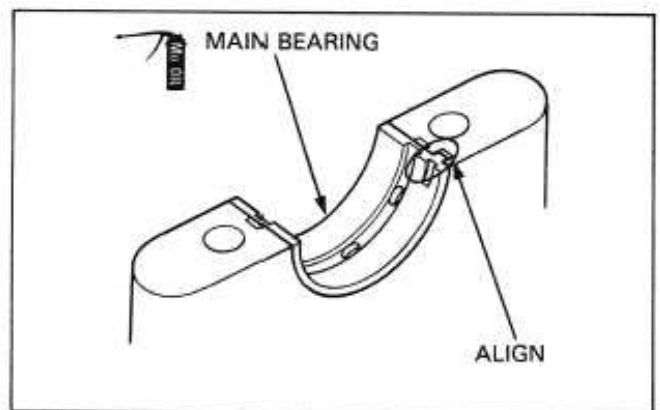

Mark a line perpendicular to the bearing surface from each edge of the notch as shown.

Apply molybdenum disulfide grease to the outer face of the bearing.

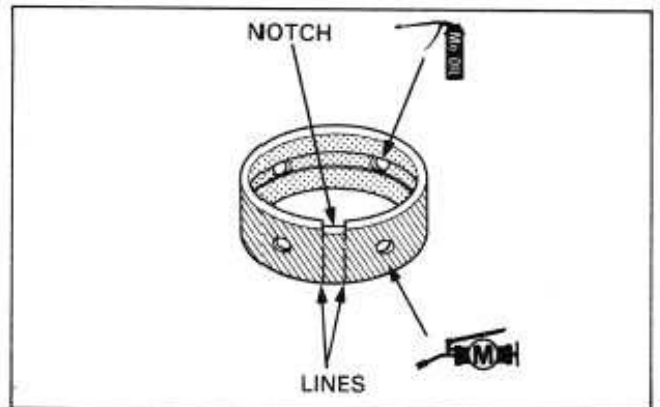

Place the bearing in the crankcase by aligning the two lines with the crankcase groove. Press it into place using a hydraulic press.

CAUTION

- Take care not to damage the inside surface of the new bearing during installation.

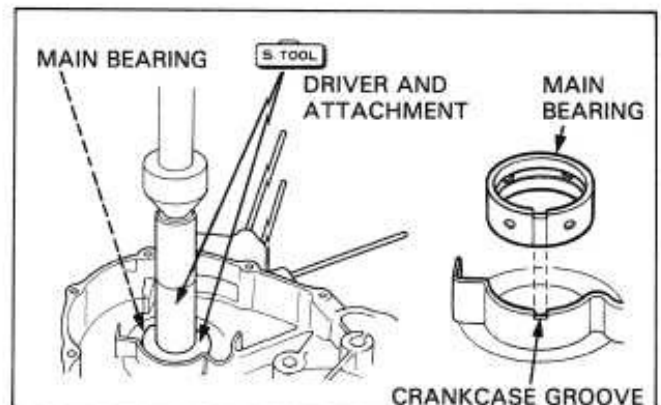

CRANKCASE/CRANKSHAFT

CONNECTING ROD BEARINGS

OIL CLEARANCE INSPECTION

Check the bearing inserts for unusual wear or damage and replace as necessary.



Wipe all oil from the bearing inserts and crankpins. Put a piece of plastigauge on each crankpin.

NOTE

- Do not put the plastigauge over the oil hole in the crankpin.

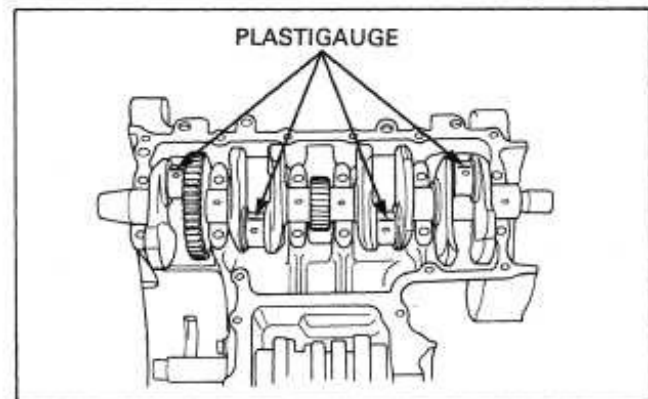

Install the bearing caps and rods on the correct crankpins, and tighten them evenly.

NOTE

- Do not rotate the crankshaft during inspection.

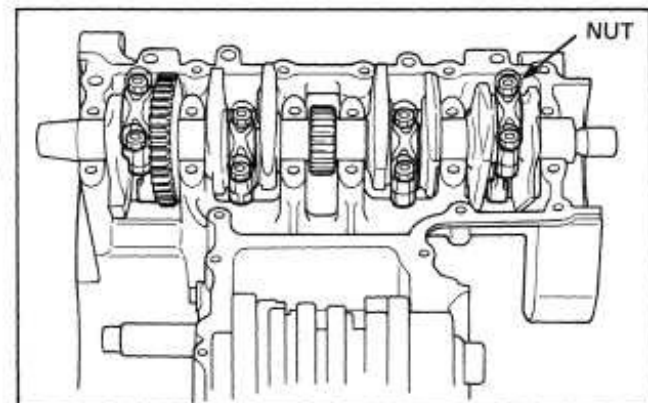

Remove the caps and measure the compressed plastigauge on each crankpin.

If the rod bearing clearance is beyond tolerance, select replacement bearings.

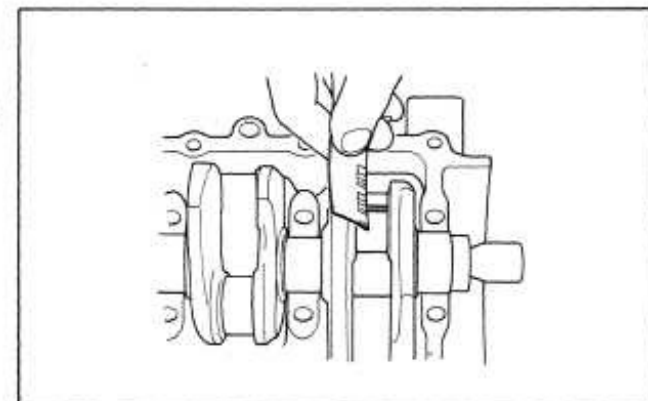

**4-STROKE
BIG END BEARING SELECTION**

Record the corresponding rod I.D. code number (1, 2 or 3) or measure the I.D. with the bearing cap installed without bearing inserts.

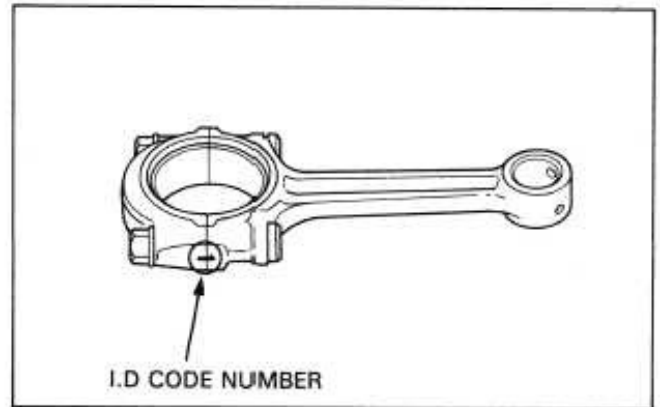

Record the corresponding crankpin O.D. code letter (A, B or C) or measure the crankpin O.D.

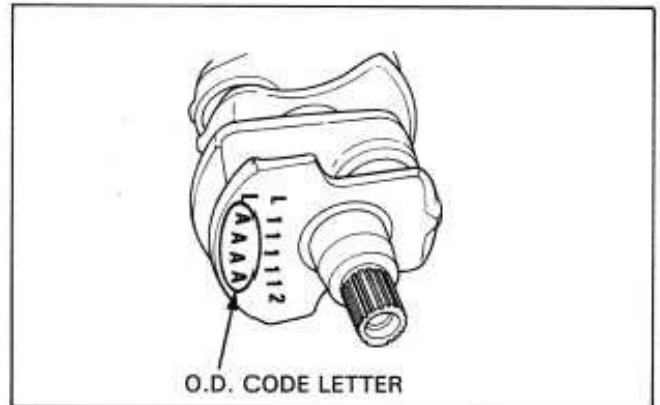

Cross-reference the crankpin and rod codes to determine the replacement bearing color.

Example:

- Crankpin code: A**
- Connecting rod code: 1**
- Bearing code: Pink**

The pink code bearing should be selected.

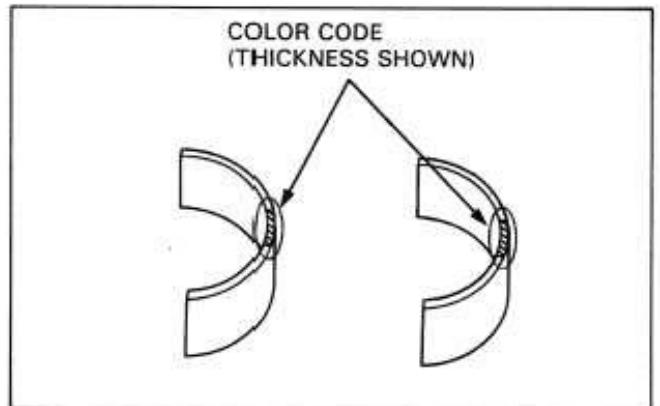

		CRANKPIN I.D. CODE	
		A	B
CONNECTING ROD I.D. CODE	1	Pink	Yellow
	2	Yellow	Green

CRANKCASE/CRANKSHAFT

BEARING REPLACEMENT

Remove the bearing inserts from the connecting rod and cap.

Wipe all oil from the connecting rod and the new bearing inserts.

Install the bearing inserts by aligning the tabs with the grooves in the connecting rod and cap.

The oil hole in the connecting rod should be aligned with the bearing insert oil hole.

Apply molybdenum disulfide solution to the inside bearing surface for initial lubrication.

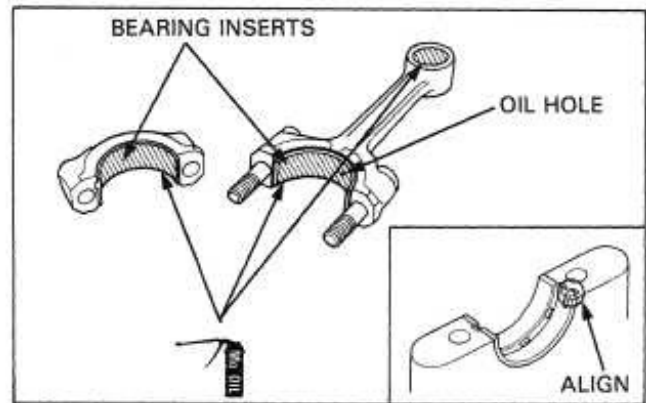

NOTE

- Molybdenum disulfide solution is a mixture of equal parts of molybdenum disulfide grease and engine oil.

CONNECTING ROD

SELECTION (MULTI CYLINDER ENGINE)

When replacement of the connecting rods requires balancing of the weights, refer to the Model Specific service manual, select the connecting rods and replace.

NOTE

- The stamped Alphabet code is the weight code.

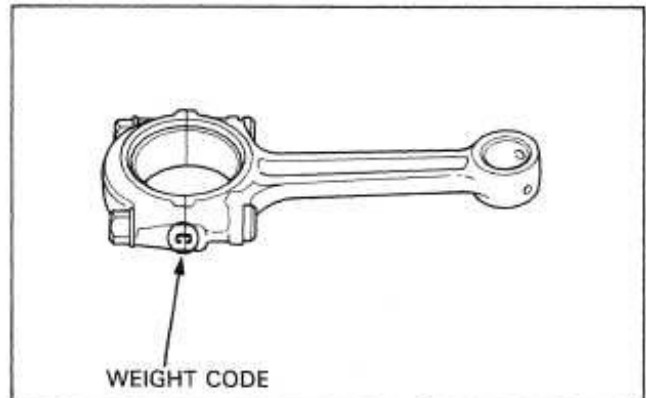

INSTALLATION

Coat the inside bearing surfaces with molybdenum disulfide solution for initial lubrication, and install them into the original positions and directions.

NOTE

- Molybdenum disulfide solution is a mixture of equal parts of molybdenum disulfide grease and engine oil.

If the connecting rod has an oil hole, install the rod so that the hole is "behind" the crankshaft rotating direction as shown.

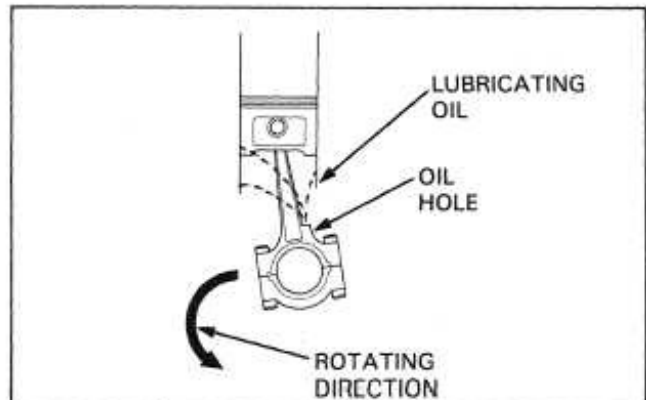

Install the bearing caps and connecting rods on the correct crankpins.

NOTE

- Install the connecting rods and bearing inserts in their original positions.
- Do not rotate the crankshaft and connecting rods during the plastigauge procedure.

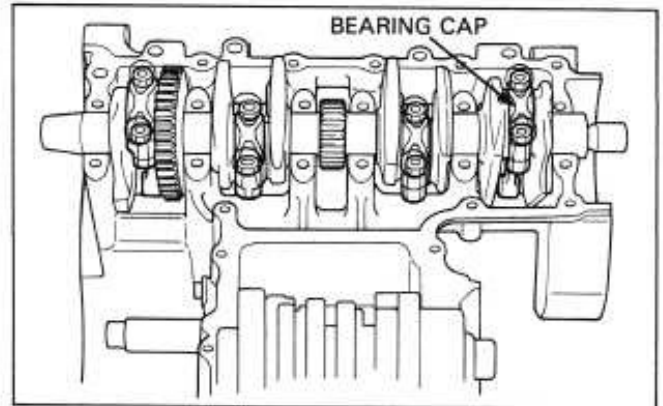

Oil the threads of the connecting rod bolts and nuts so that the bolts will be tightened evenly. Tighten the nuts to the specified torque.

After tightening, check that the connecting rods move freely without binding.

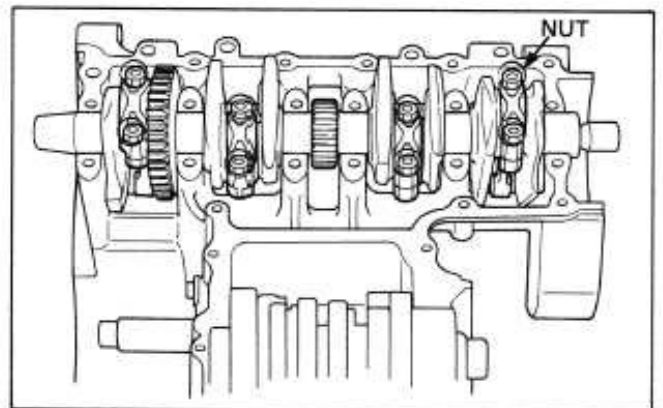

MEMO

15. FINAL DRIVE/OUTPUT SHAFT

SERVICE INFORMATION	15-1	OUTPUT SHAFT	15-2
TROUBLESHOOTING	15-1	FINAL DRIVE	15-5
SYSTEM DESCRIPTION	15-2		

SERVICE INFORMATION

- Inspect the gear contact pattern and backlash whenever you replace the bearings, gears or gear case. Extension lines plotted from the gear engagement surfaces should intersect at one point.

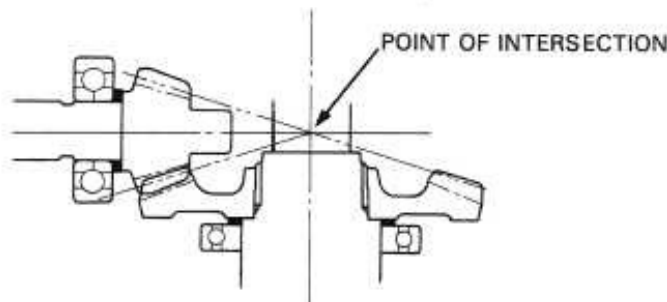

- Check the ring gear-to-gear case cover stop pin clearance whenever the ring gear is removed/replaced.
- Replace the final drive shaft, side gear case, output shaft, and the ring and pinion gears of the final gear case as a set.
- Protect the gear case with a shop towel when holding it in a vise. To avoid damaging the case, do not clamp it too tight.
- When tightening the lock nut with a lock nut wrench, the actual torque on the nut is greater than the reading by the length of the lock nut wrench.
Refer to the Model Specific manual for the specified torque. Do not overtighten the lock nut.
- Gear tooth engagement:

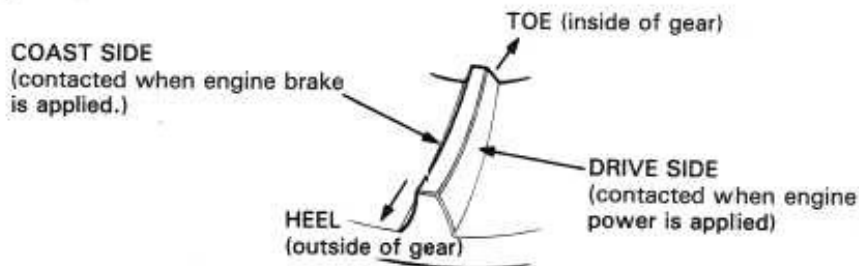

15

TROUBLESHOOTING

Excessive noise in final drive

- Worn or damaged ring gear and driven flange
- Damaged driven flange or wheel hub
- Worn or damaged pinion gear and/or pinion joint splines
- Excessive backlash between pinion and ring gear.
- Low oil level

Excessive noise in side gear

- Worn or damaged output shaft and final drive shaft gears
- Worn or damaged side gear case bearing
- Incorrect adjustment shim

Excessive rear wheel backlash

- Worn drive shaft splines
- Excessive backlash between ring gear and pinion gear
- Worn driven flange and ring gear splines
- Excessive play in final drive case bearings
- Worn drive shaft, universal joint and/or pinion joint splines
- Excessive play or worn universal joint bearing.

Oil leak at final gear case

- Clogged breather hole
- Too much oil
- Faulty oil seal(s)

FINAL DRIVE/OUTPUT SHAFT

SYSTEM DESCRIPTION

Power from the engine is transmitted to the rear wheel as follows:

Countershaft (or output drive gear) → output driven gear → drive shaft → pinion gear → ring gear → rear wheel.

To prevent harsh or jerky acceleration or deceleration, a damper spring is placed in the drive line. The spring absorbs sudden applications of torque and provides smooth starts and stops.

A damper mechanism is attached to either the output gear case or the drive shaft.

Unlike a drive chain, the gear driven system requires only periodic gear oil changes for maintenance.

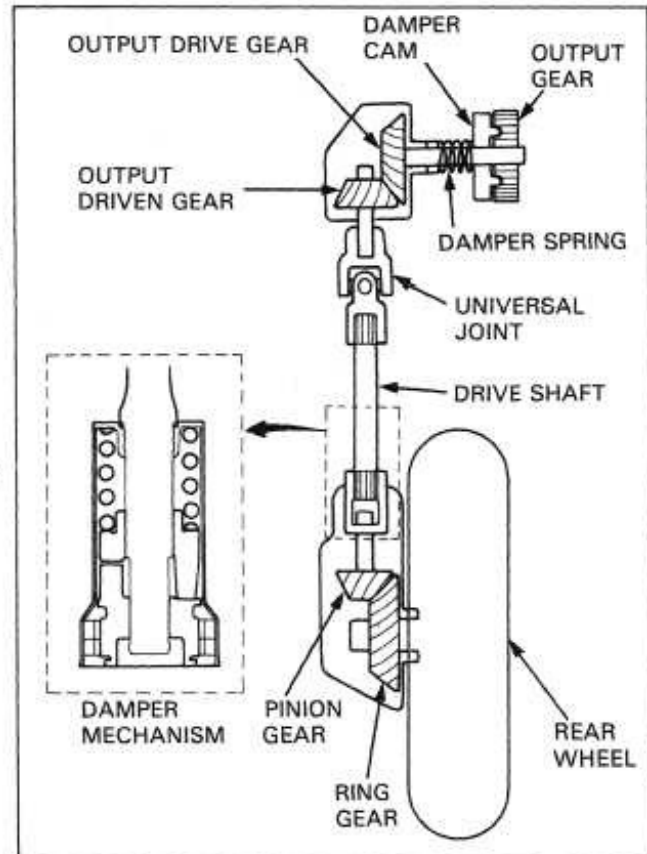

OUTPUT SHAFT

REMOVAL

NOTE

- When a damper spring is installed at the output gear, remove the side gear case only after the damper spring has been removed. Follow the steps below.
- Refer to the Model Specific manual for output shaft removal.

Remove the output gear.

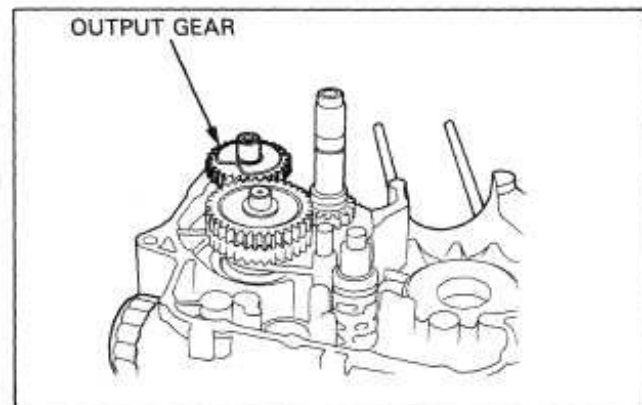

Using the damper spring compressor, compress the damper spring and remove the snap ring. Remove the damper spring compressor and then take out the damper cam and damper spring.

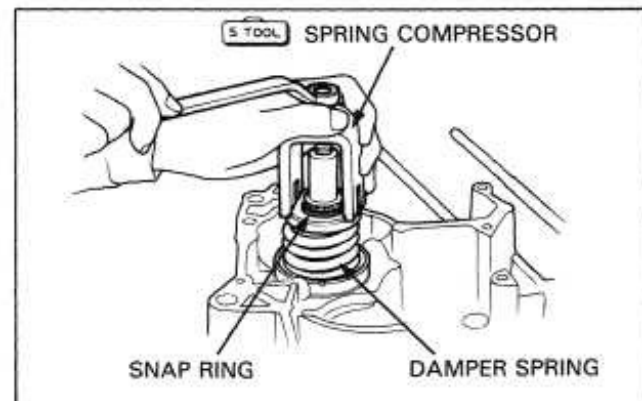

INSPECTION

Check the gear and the dog holes for abnormal or excessive wear, or signs of insufficient lubrication; replace as necessary.

Measure the gear I.D.. Replace the gear if the service limit is exceeded.

Check the bushing for wear or damage.

Measure the bushing I.D. and O.D.. Replace the bushing if the service limit is exceeded.

Calculate the gear-to-bushing clearance. Replace either component if its service limit is exceeded.

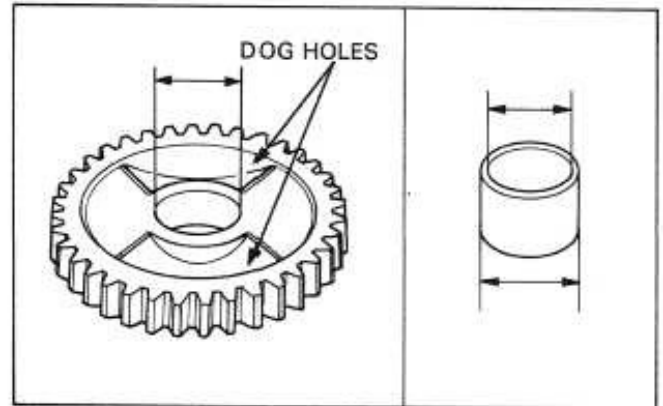

Measure the O.D. of the countershaft or output drive shaft at the sliding area. Replace the shaft if the service limit is exceeded.

Calculate the shaft-to-bushing clearance. If it is beyond the service limit, determine if a new bushing would bring the clearance within tolerance. If so, replace the bushing. If the clearance still exceeds the service limit with a new bushing, replace the shaft.

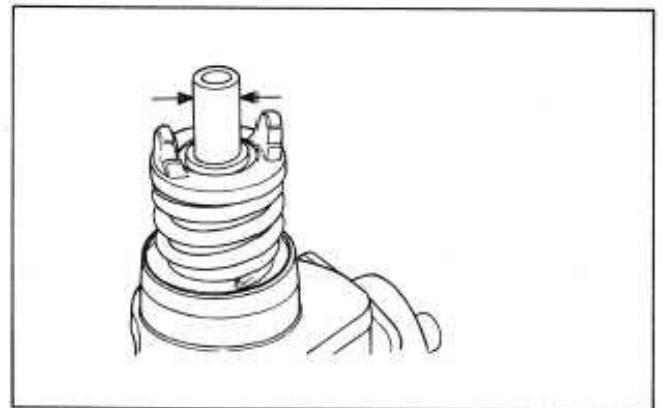

Measure the damper spring free length. Replace the spring if the free length exceeds the service limit.

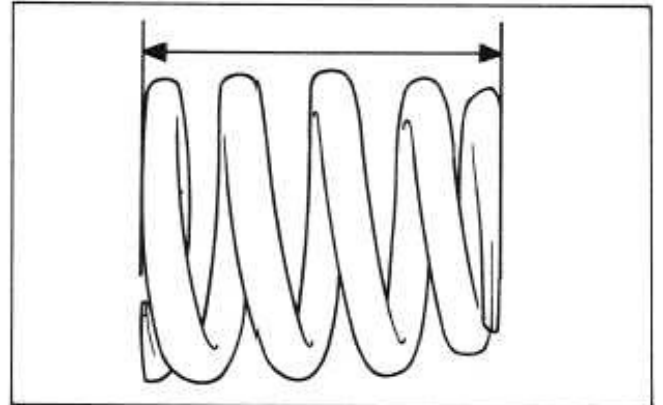

BACKLASH INSPECTION

Clamp the output gear case in a soft jaw vise or use a shop towel to cushion the case.

Set a horizontal type dial indicator on the countershaft or output drive shaft as shown.

Hold the driven gear with the shaft holder and rotate the shaft by hand until gear slack is taken up.

Turn the countershaft or output drive shaft back and forth to read the backlash.

Remove the dial indicator. Turn the countershaft or output drive shaft 120° and measure backlash. Repeat this procedure once more.

Compare the difference between the three measurements.

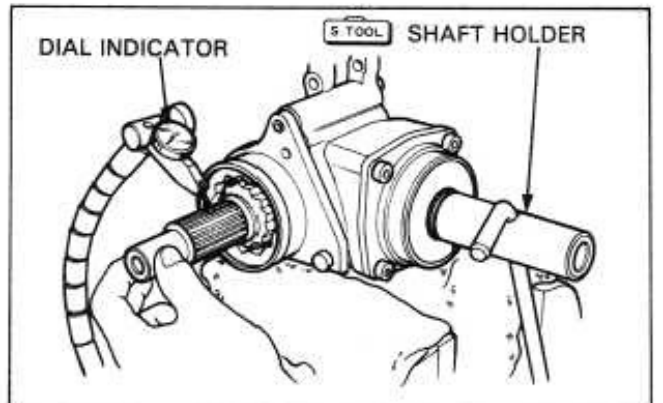

FINAL DRIVE/OUTPUT SHAFT

If the difference in measurements exceeds the limit, the shaft bearing is probably not installed squarely. Inspect the bearing and reinstall if necessary.

If backlash is excessive, replace the countershaft or output drive shaft adjustment shim with a thinner one.

If the backlash is too small, replace the countershaft or output drive shaft shim with a thicker one.

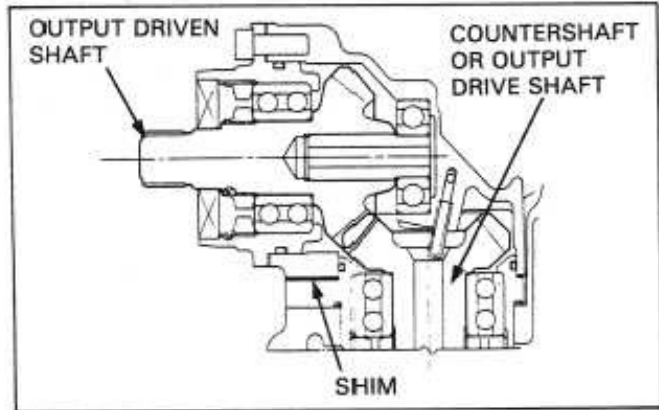

Gear tooth contact pattern check

Remove the countershaft or output drive shaft from the side gear case.

Apply Prussian Blue to the output drive gear teeth.

Install the countershaft or output drive shaft and the shim.

Rotate the drive shaft several times in the normal direction of rotation.

Remove the shaft and check the gear tooth contact pattern.

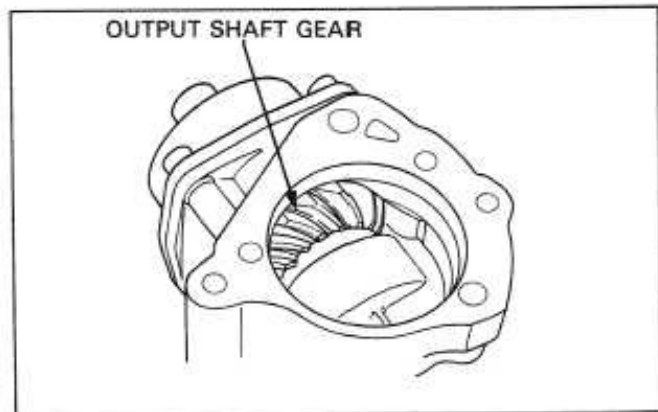

Contact is normal if Prussian Blue is transferred to the approximate center of each tooth.

If the pattern is not correct, remove the output driven shaft and replace the shaft adjustment shim.

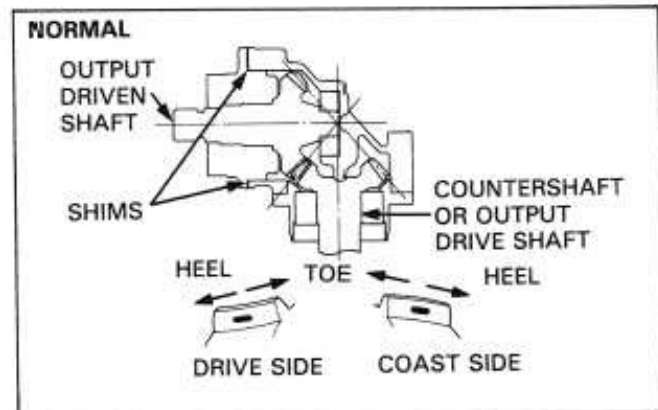

Replace the shim with a thinner one if the contact pattern is too high (on the face end).

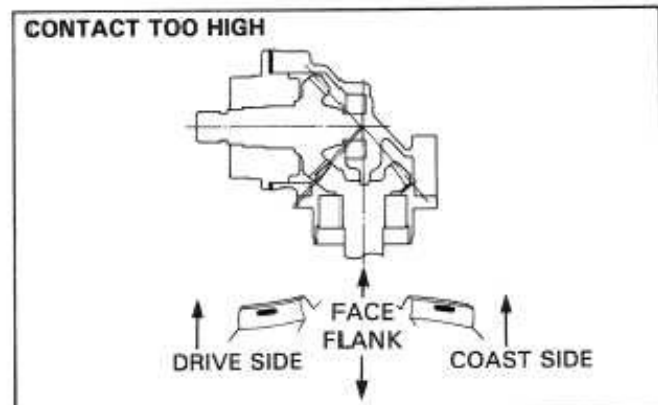

Replace the output shaft adjustment shim with a thicker one if the contact is too low (on the flank end).

Refer to the Model Specific manual for information about shim thickness selections.

CONTACT TOO LOW

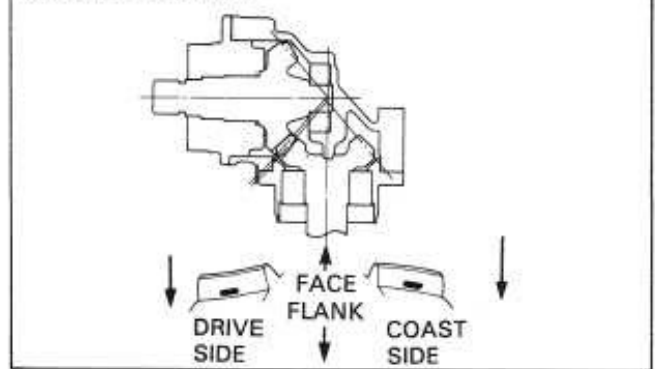

INSTALLATION

Refer to the Model Specific manual for side gear case installation.

If the damper spring was removed, install it according to the following procedure:

Place the damper spring and damper cam over the shaft. Install the damper spring compressor and compress the spring, then install the snap ring securely.

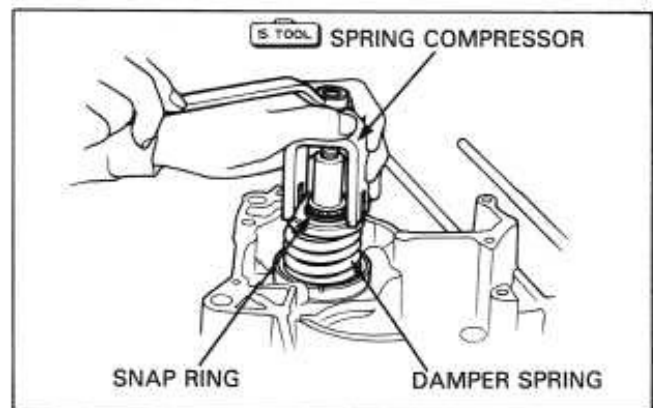

FINAL DRIVE

REMOVAL

Drain the final gear oil and remove the rear wheel. Remove the mounting nuts, and remove the final drive assembly.

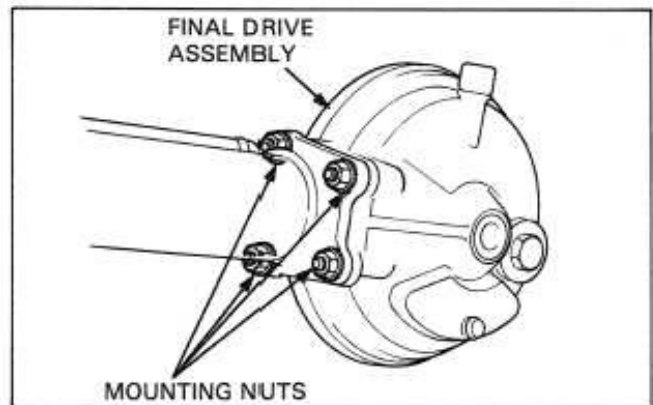

DRIVE SHAFT REMOVAL

With Damper Case:

Hold the drive shaft in a soft jaw vise and separate the final gear case from the drive shaft.

CAUTION

- Use care when clamping the damper case section of the final drive assembly in a vise to avoid damaging it.

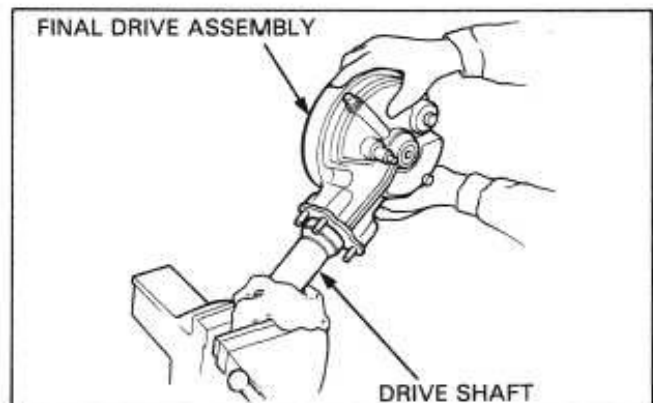

FINAL DRIVE/OUTPUT SHAFT

Without Damper Case:

Separate the drive shaft from the final gear case by gently turning the drive shaft and pulling.

Remove the spring and oil seal.

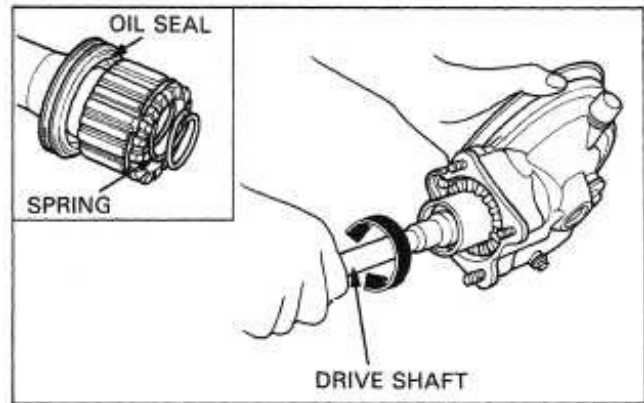

DRIVE SHAFT/DAMPER DISASSEMBLY

Drain the oil from the damper case.

Set the drive shaft in the shock absorber compressor with the proper attachments.

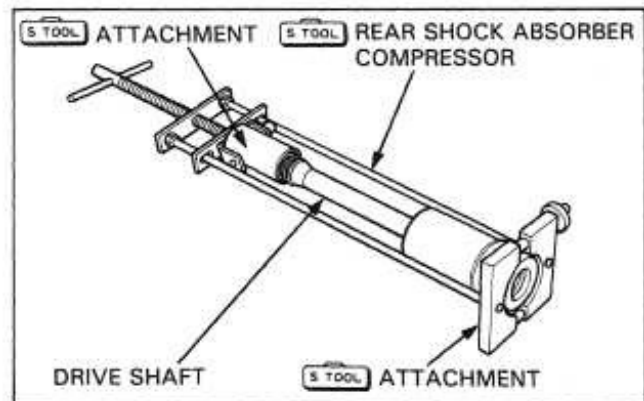

Compress the damper spring and remove the stop ring.

Remove the tool.

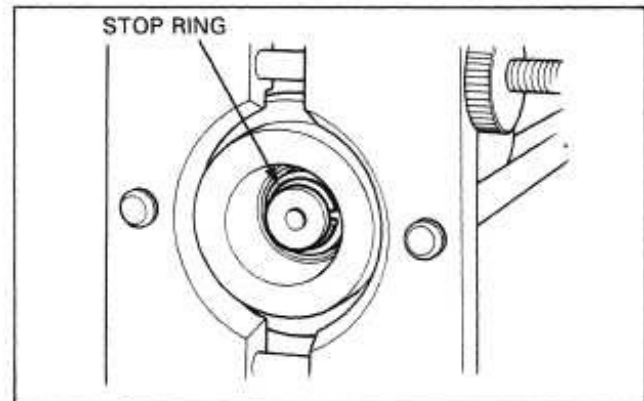

Remove the following:

- spring seat
- damper cam
- damper lifter
- damper case
- O-ring
- snap ring
- spring

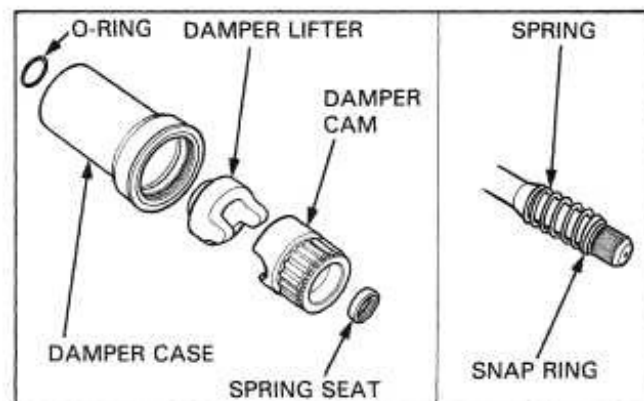

Remove the oil seal, oil seal guide and damper spring from the damper case.



DRIVE SHAFT INSPECTION

Measure the damper spring free length. Replace the spring if the free length exceeds the service limit.

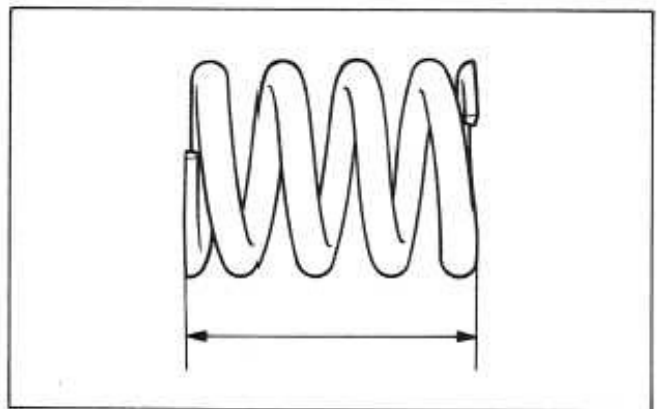

Check the drive shaft splines for excessive or abnormal wear; replace as necessary.

If the splines are wear-damaged, check the universal joint splines also.

Check the damper cam and lifter for damage; replace as necessary.

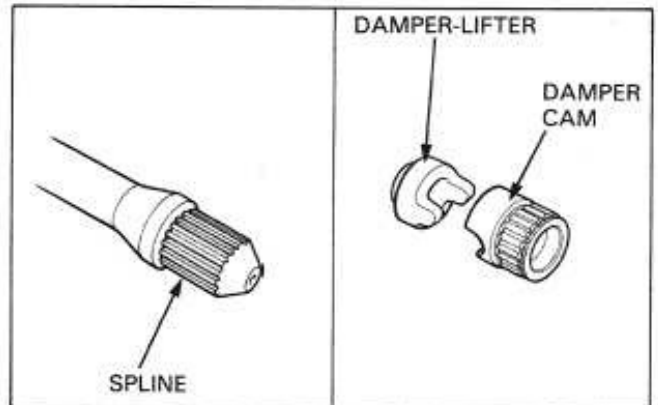

DAMPER CASE ASSEMBLY

Install the spring in the damper case.

Install the oil seal guide and a new oil seal using the special tool.

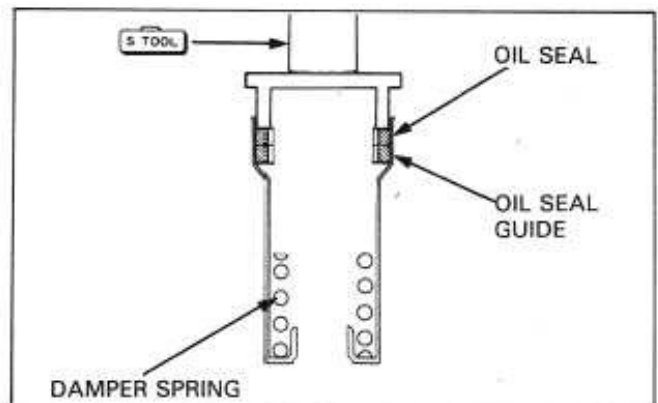

FINAL DRIVE/OUTPUT SHAFT

Install a new O-ring onto the drive shaft.

Install the shaft spring and secure the snap ring.

Insert the drive shaft into the damper case.

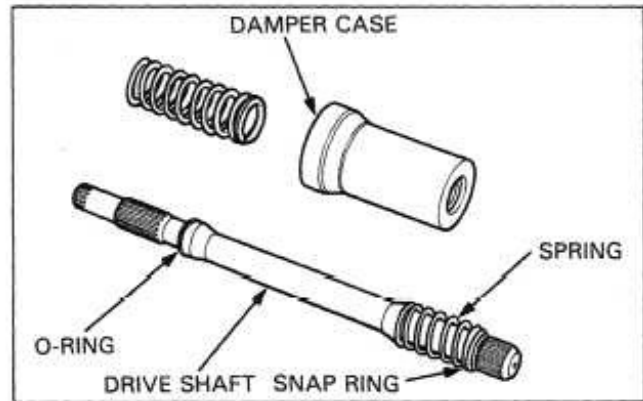

Install the damper lifter, damper cam and spring seat.

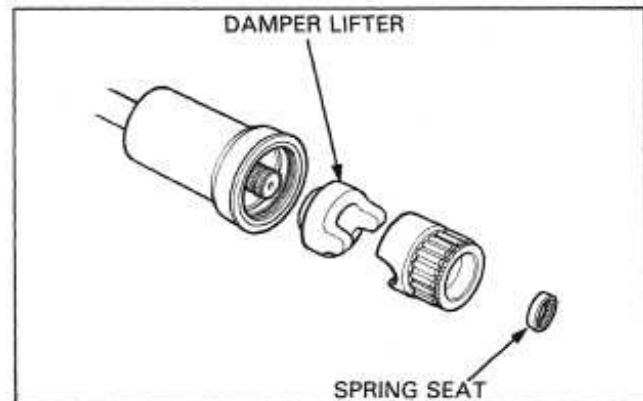

Set the drive shaft in the shock absorber compressor and compress the spring.

Set the stop ring securely into the groove on the drive shaft.

Remove the tools.

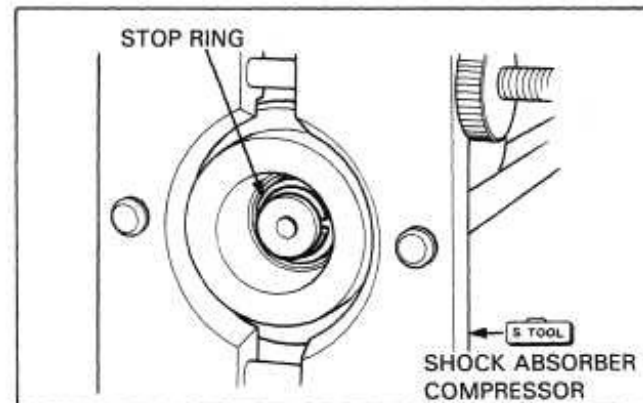

DRIVE SHAFT INSTALLATION

With Damper Case:

Fill the damper case with the recommended type and amount of gear oil.

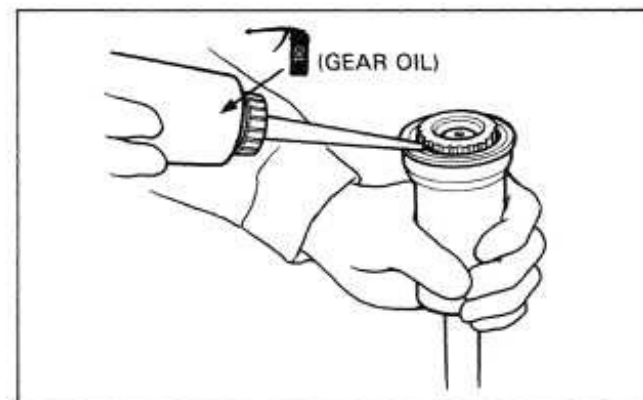

FINAL DRIVE/OUTPUT SHAFT

Hold the drive shaft upright to avoid spilling the oil.

Carefully position the gear case on the shaft.

CAUTION

- Avoid damaging the damper case oil seal during assembly.

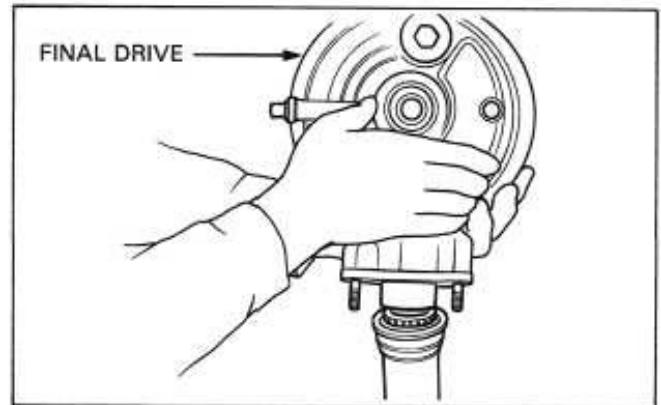

Without Damper Case:

Install a new oil seal, stop ring and spring, then install the shaft on the final drive assembly.

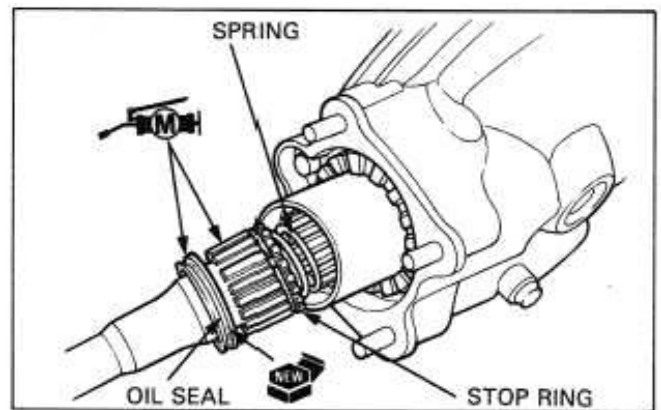

UNIVERSAL JOINT INSPECTION

Remove the swingarm (see the Model Specific manual).

Remove the universal joint from the output shaft.

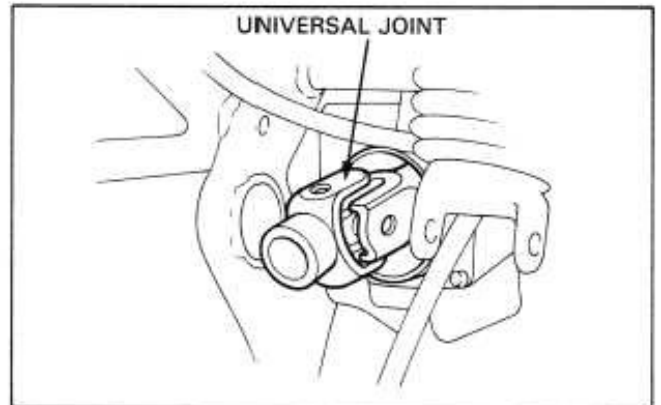

Check that the universal joint moves smoothly without binding or noise.

Check the splines for wear or damage and replace the joint if necessary.

Install the universal joint on the output shaft, then install the swingarm.

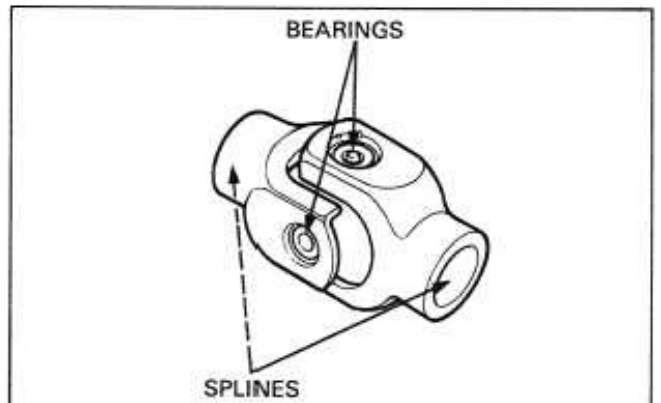

FINAL DRIVE/OUTPUT SHAFT

FINAL DRIVE INSPECTION

Turn the pinion joint and check that the ring gear turns smoothly and quietly without binding.

If the gear does not turn smoothly or quietly, the bearing may be improperly installed, and/or pinion/ring gear may be damaged.

Check the backlash first, then service the appropriate component(s).

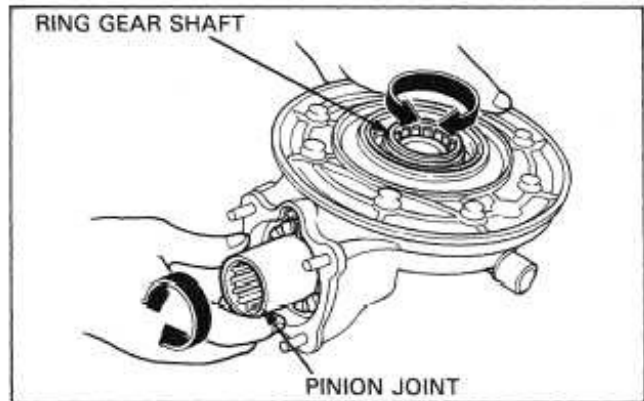

BACKLASH INSPECTION

Remove the oil filler cap.

Set the final gear assembly into a jig or vise with soft jaws.

Hold the pinion gear splines with pinion joint holder.

Set a horizontal type dial indicator on the ring gear through the oil filler hole.

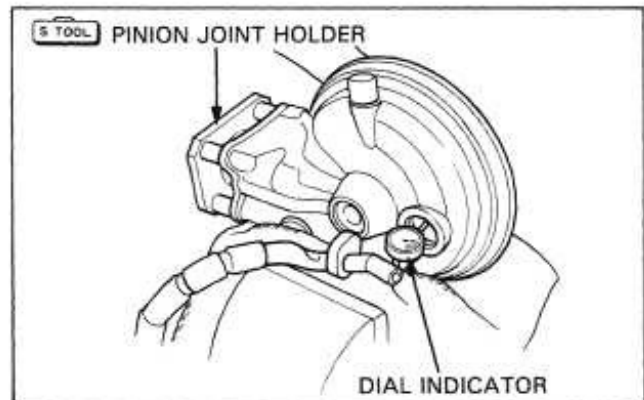

Turn the ring gear back and forth to read backlash.

Remove the dial indicator and the pinion joint holder. Turn the ring gear 120° and reinstall the pinion joint holder. Reinstall the dial indicator and measure backlash. Repeat this procedure once more.

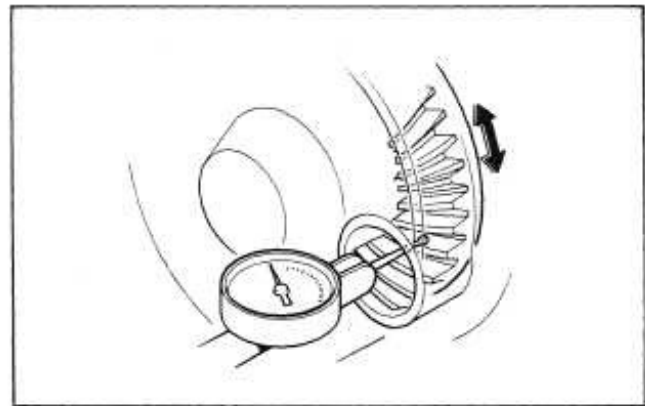

If the difference in measurements exceeds the limit specified in the Model Specific manual, it indicates that the ring gear bearing is not installed squarely.

Inspect the bearing and reinstall if necessary.

If backlash is excessive, replace the ring gear shim with a thicker one.

If the backlash is too small, replace the ring gear shim with a thinner one.

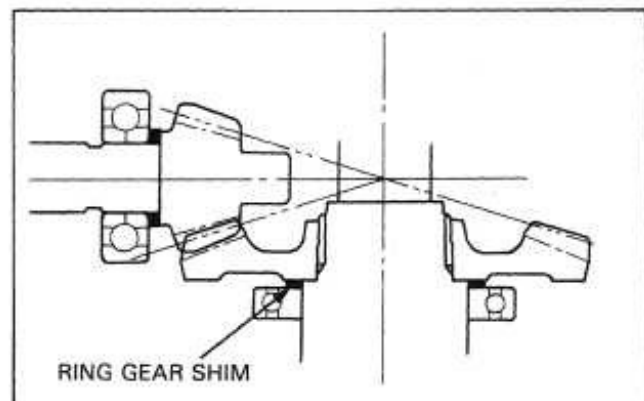

RING GEAR REMOVAL/SHIM REPLACEMENT

Remove the distance collar.

Remove the bolt and dust guard plate.

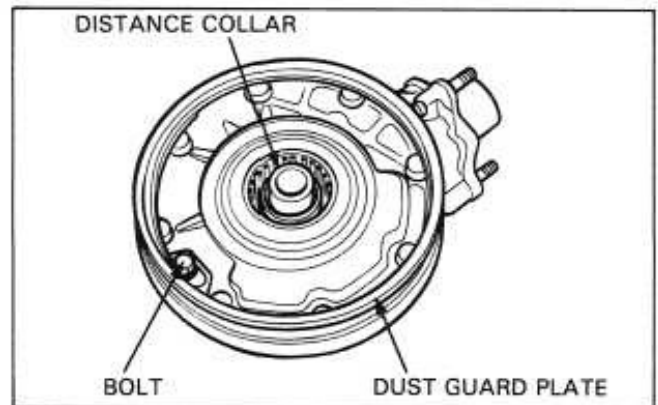

Loosen the case cover bolts in a crisscross pattern in 2 or 3 steps.

Remove the gear case cover.

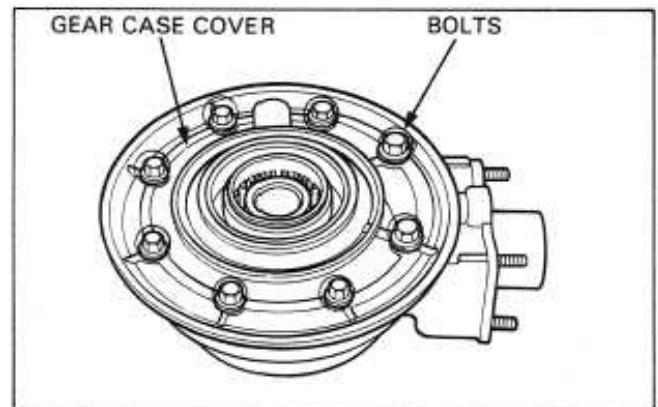

If the ring gear stays in the cover:

Support the cover horizontally with the ring gear facing down, and press the gear out using a hydraulic press.

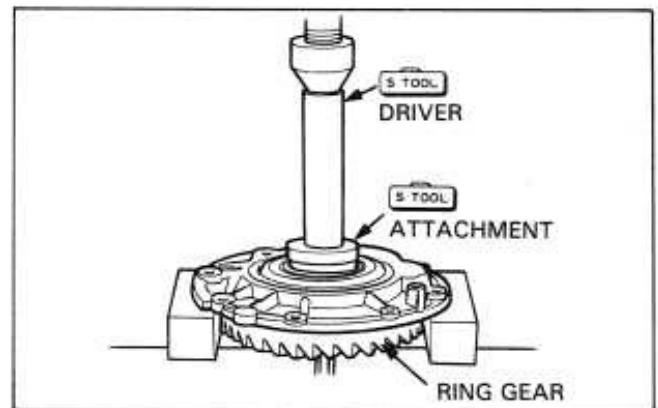

Remove the ring gear from the case.

Remove the O-ring guide by tapping it from the opposite side.

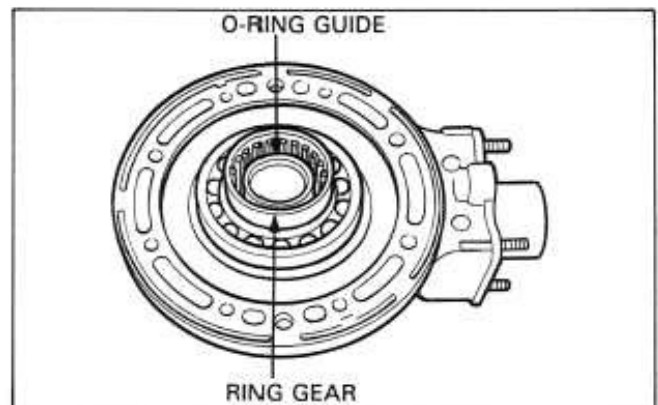

FINAL DRIVE/OUTPUT SHAFT

Remove the ring gear bearing using a bearing puller.

NOTE

- This bearing may not need to be replaced after removal. However, inspect the bearing for noise and/or excessive play after removal.

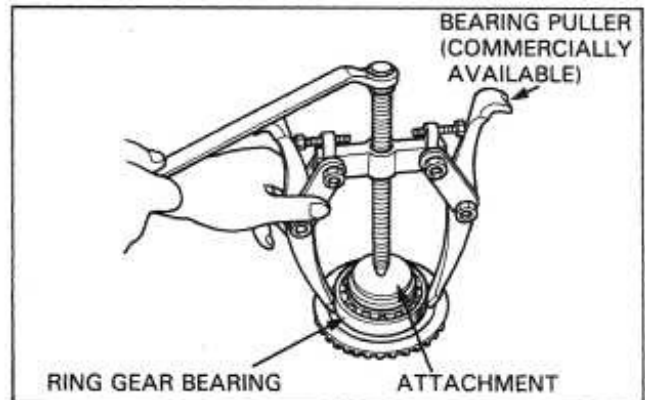

Replace the bearing adjustment shim.

NOTE

- If the gear set, pinion bearing and/or gear case are replaced, install a new shim. (Refer to the Model Specific manual for shim thickness.)

Place the bearing on the ring gear.

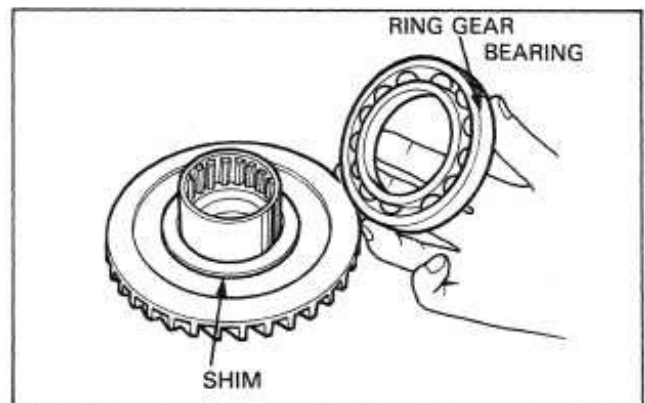

Drive the bearing over the shaft squarely

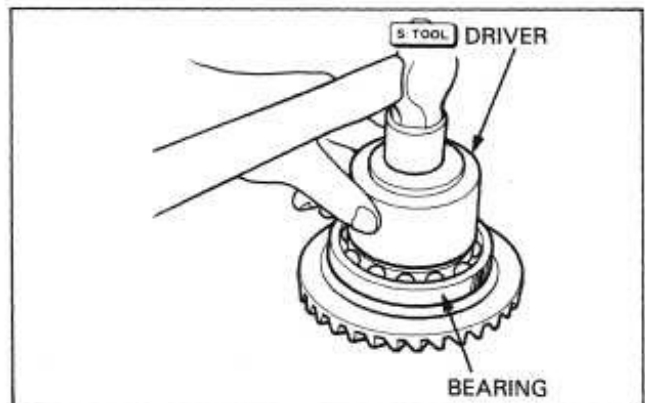

Install a new O-ring onto the O-ring guide.

Drive the O-ring guide into the ring gear.

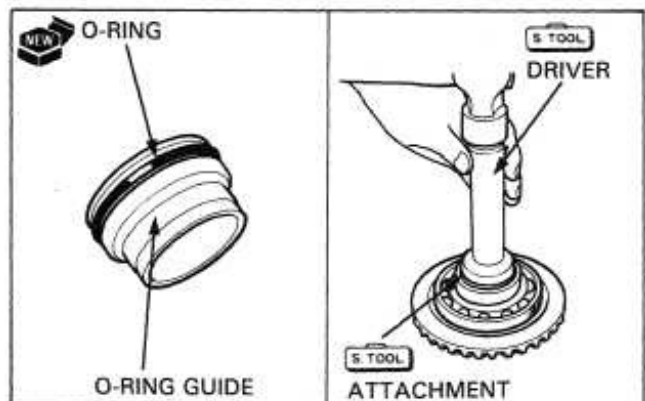

Remove and discard the oil seal.

Install a new oil seal.

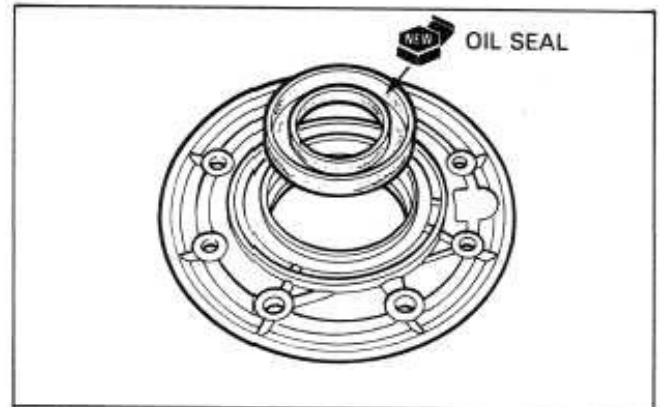

Install the ring gear into the gear case cover.

Measure the clearance between the ring gear and the ring gear stop pin with a feeler gauge.

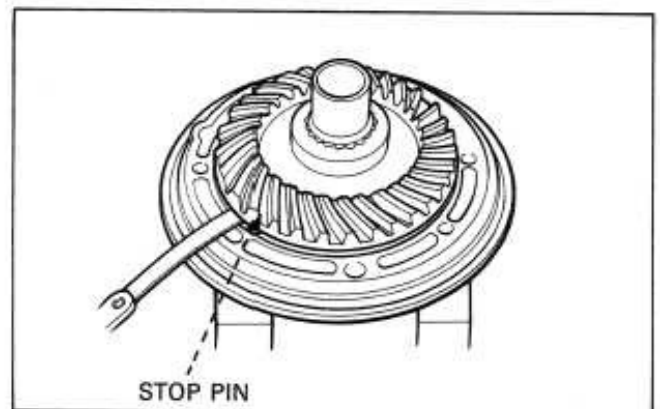

If the clearance exceeds the limit, remove the ring gear. Heat the gear case cover to approximately 80°C (176°F) and remove the stop pin by tapping the cover.

WARNING

- To prevent burns, always wear insulated gloves when handling the heated gear case.

Heat the case cover evenly and slowly to prevent warpage. Do not heat small areas individually.

CAUTION

- Case cover warpage can occur if the cover is not heated properly.

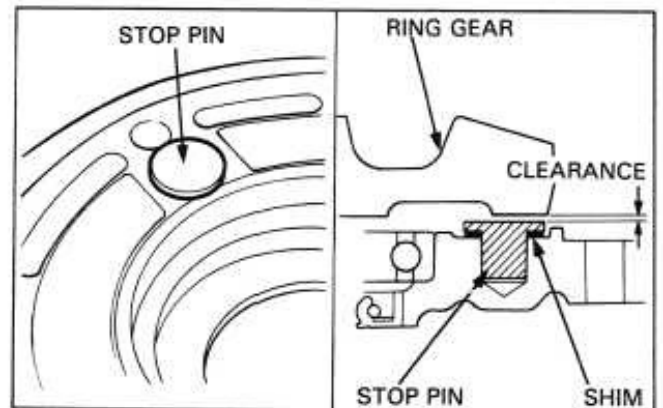

Select a stop pin shim that will provide the correct clearance.

Install the shim and drive the stop pin into the case cover.

Clean all sealing material off the mating surface of the gear case and cover.

NOTE

- Keep dust and dirt out of the gear case.
- Be careful not to damage the mating surfaces.

Check the gear tooth contact pattern after the ring gear shim has been replaced (see page 15-14).

FINAL DRIVE/OUTPUT SHAFT

GEAR TOOTH CONTACT PATTERN CHECK

Apply a thin coat of Prussian Blue to the pinion gear teeth for a gear tooth contact pattern check.

Place the wave washer and ring gear into the gear case.

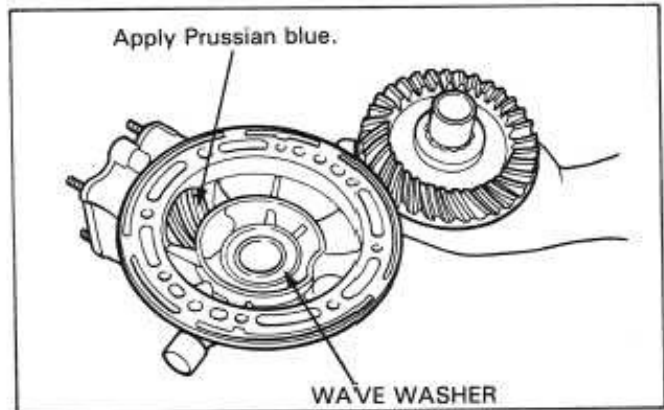

Apply gear oil to the lip of the oil seal on the gear case cover and install the gear case cover.

Tighten the cover bolts in 2 or 3 steps until the cover evenly touches the gear case, then tighten the 8 mm bolts to the specified torque in a crisscross pattern in two or more steps.

Next tighten the 10 mm bolts to the specified torque.

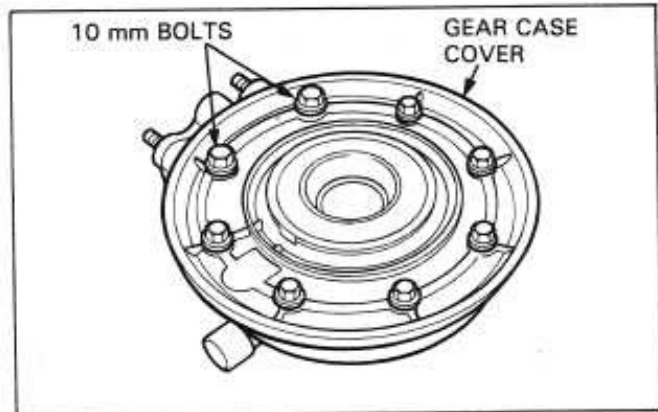

Remove the oil filler cap from the final gear case.

Rotate the ring gear several times in the normal direction of rotation.

Check the gear tooth contact pattern as marked by the Prussian Blue through the oil filler hole.

Contact is normal if the Prussian Blue is transferred to the approximate center of each tooth and slightly to the flank side.

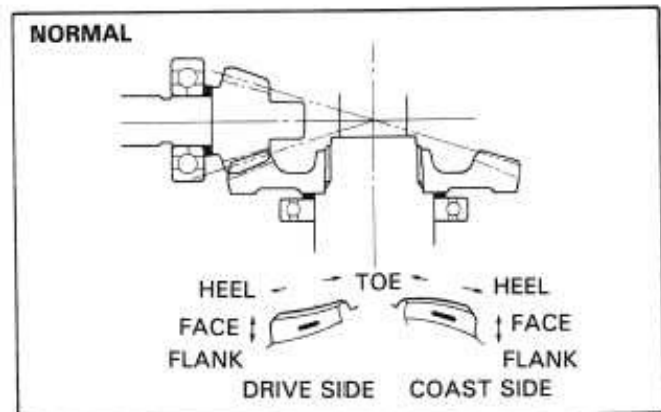

If the pattern is not correct, remove and replace the pinion shim.

Replace the pinion shim with a thicker one if the contacts are too high.

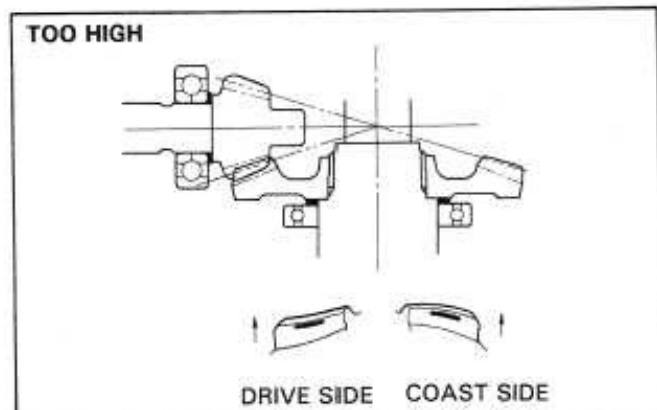

Replace the pinion shim with a thinner one if the contacts are too low.

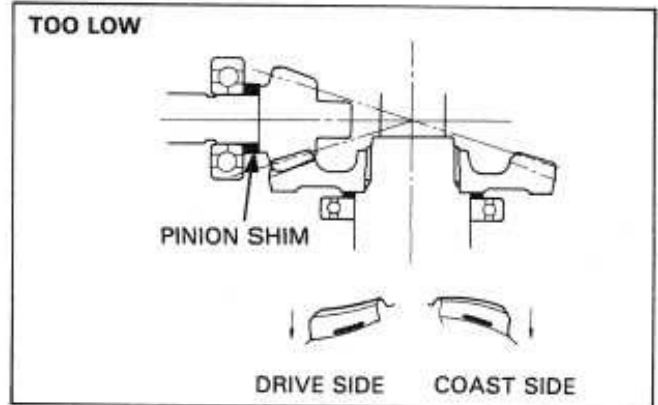

PINION GEAR REMOVAL/SHIM REPLACEMENT

Place the final gear case in a soft jaw vise or use a shop towel.

Install the pinion joint holder onto the pinion joint and remove the pinion shaft nut.

Remove the tool and the pinion joint.

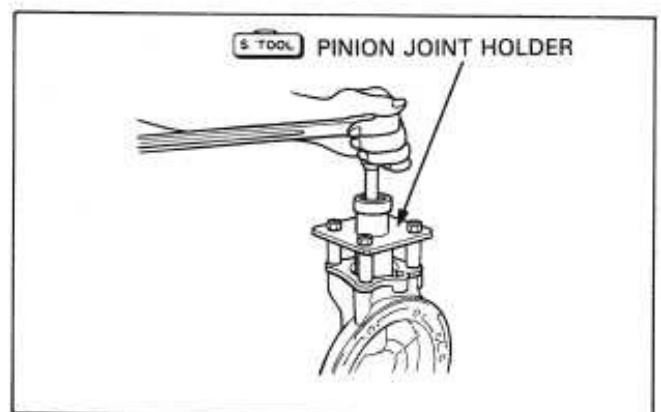

Remove the bolt and the retainer lock plate.

Remove the pinion retainer with the pinion retainer wrench.

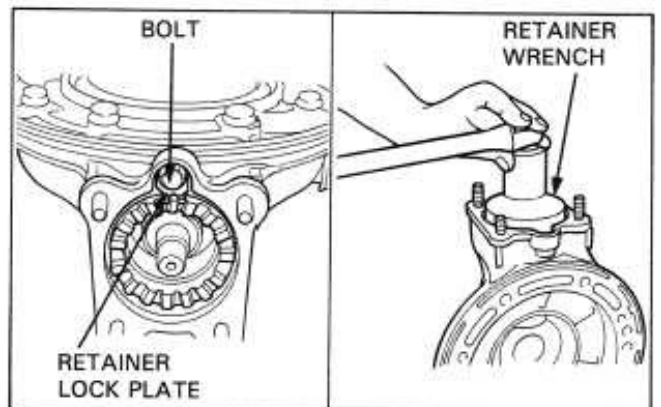

Pull off the pinion assembly with the pinion puller.



FINAL DRIVE/OUTPUT SHAFT

Remove the O-ring from the pinion shaft.

Pull the bearing outer and inner races from the shaft with the bearing puller.

NOTE

- This bearing may not need to be replaced after removal. However, inspect the bearing for noise and/or excessive play after removal.

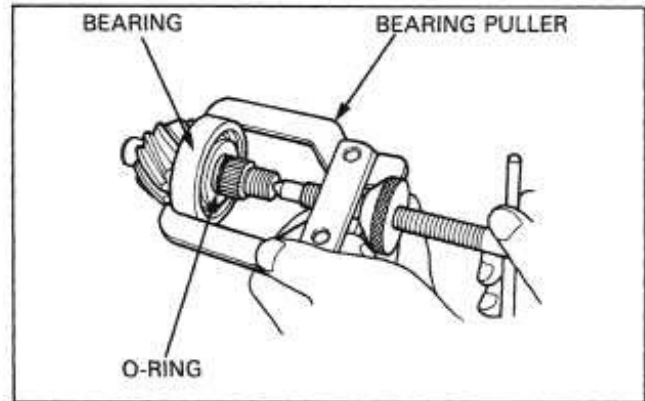

Replace the pinion shim.

NOTE

- If the gear set, pinion bearing, ring gear bearing and/or gear case are replaced, the shim must be replaced. (Refer to the Model Specific manual for shim thickness.)



Drive the pinion gear bearing onto the pinion gear using the special tool.

Apply gear oil to a new O-ring and install it on the pinion gear.

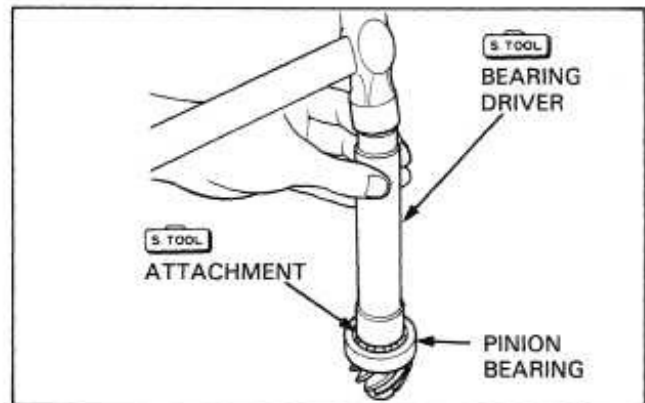

Remove and discard the O-ring and oil seal from the bearing retainer.

Install a new oil seal on the retainer.

Coat a new O-ring with gear oil and install it.

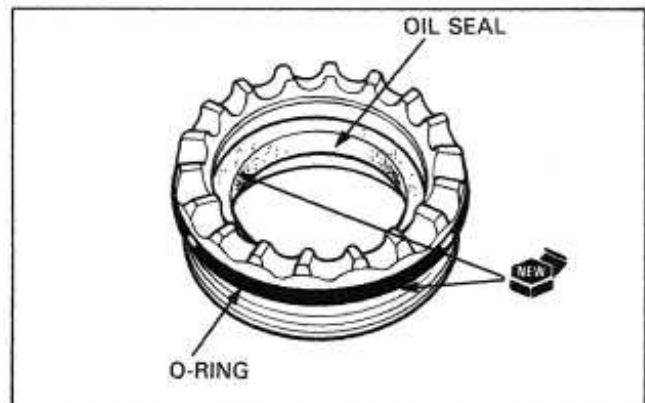

PINION GEAR INSTALLATION

Place the gear case in a soft jaw vise or use a shop towel. Drive the pinion assembly into the gear case until the gear case threads will accept pinion retainer threads.

CAUTION

- Be careful not to damage the gear case when driving the pinion assembly in.

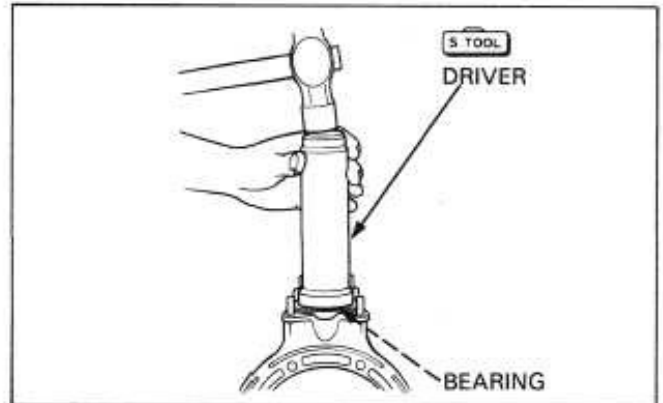

Apply gear oil to the bearing retainer, oil seal lip, and the pinion retainer threads.

Screw in the pinion retainer to press the pinion bearing in place, then tighten the retainer to the specified torque.

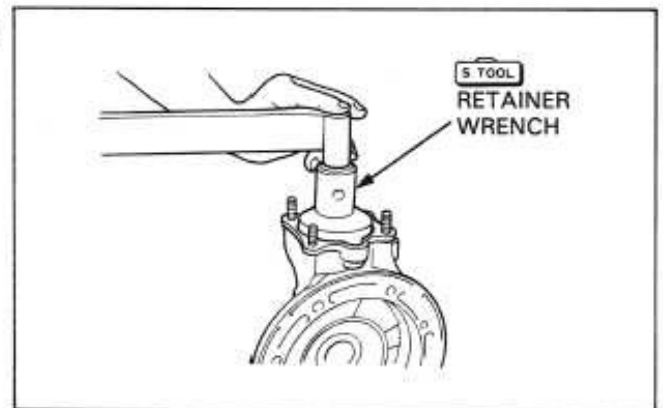

Install the appropriate lock plate, depending on the position of the pinion retainer grooves in relation to the lock plate tabs when the retainer is properly torqued.

NOTE

- The lock plates are available in the two types shown.

Tighten the bolt to the specified torque.

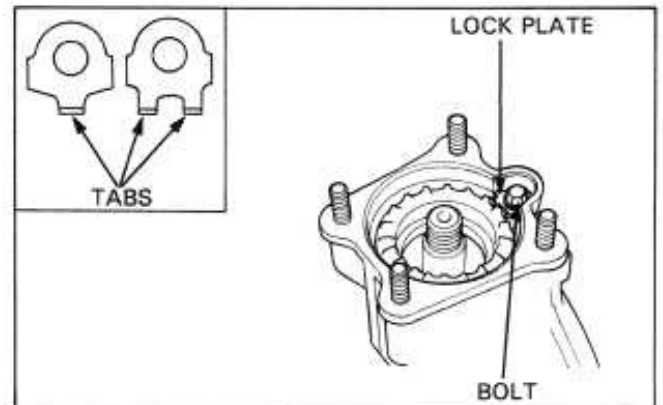

Apply gear oil to the oil seal lip surface and install the pinion joint.

Screw in the pinion joint nut by hand as far as it goes.

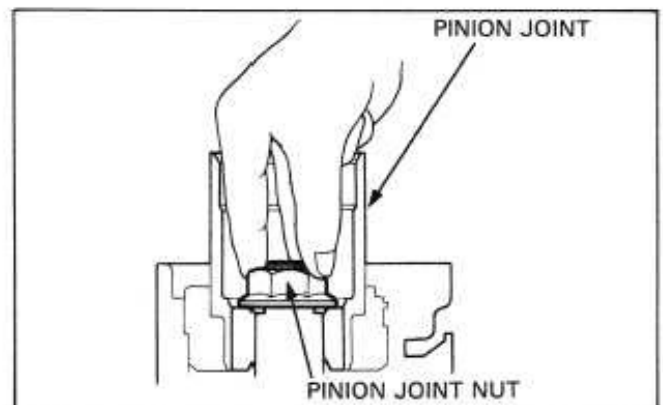

FINAL DRIVE/OUTPUT SHAFT

Hold the pinion joint using pinion joint holder and tighten the joint nut to the specified torque.

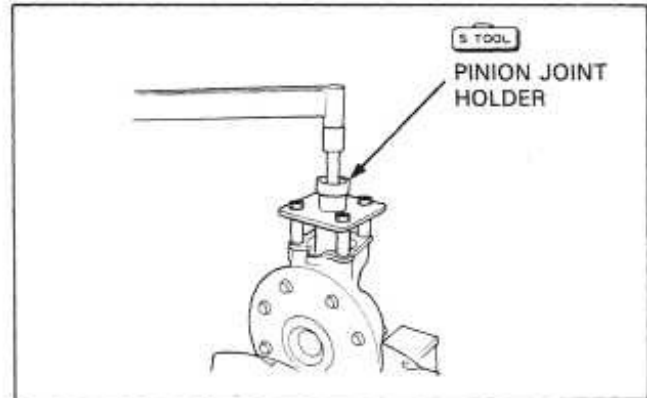

CASE BEARING REPLACEMENT

Heat the gear case evenly to 80°C (176°F) using a heat gun.

To remove the bearing, hold the gear case so that the bearing is horizontal and tap the bearing out of the case with a plastic hammer.

⚠ WARNING

- To prevent burns, always wear insulated gloves when handling the heated gear case.

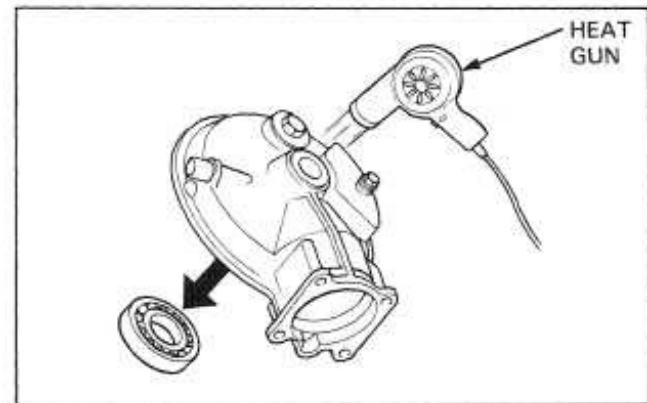

Remove the oil seal and discard it.

Oil the new oil seal and drive it into the case.

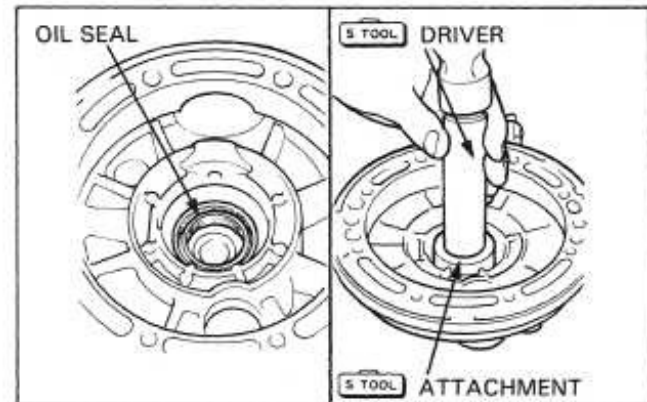

Drive a new ring gear bearing into the gear case.

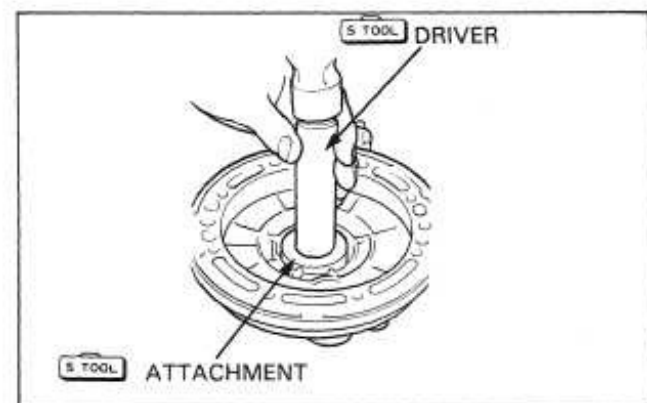

BREATHER HOLE CLEANING

Remove the breather hole cap and blow compressed air through the hole.

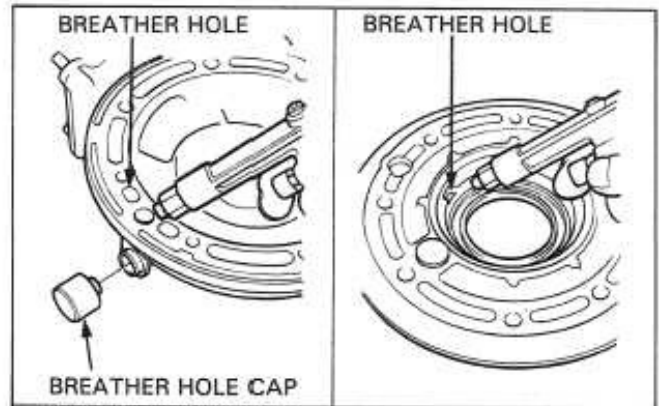

GEAR CASE ASSEMBLY/INSTALLATION

Clean all sealing material off the mating surfaces of the gear case and cover.

NOTE

- Keep dust and dirt out of the gear case.
- Be careful not to damage the mating surfaces.

Apply liquid sealant to the mating surfaces of the gear case and cover.

Install the gear case cover.

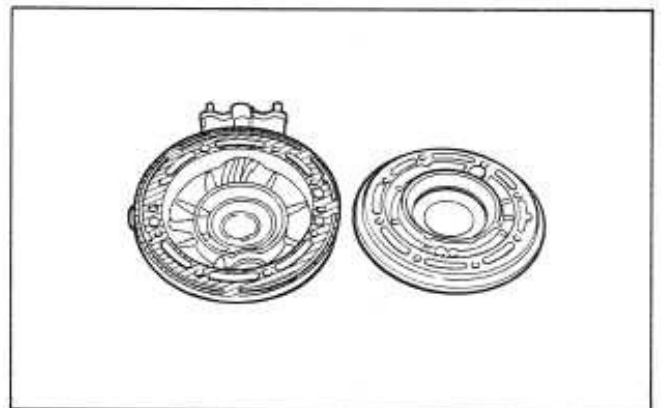

Tighten the cover bolts in 2 or 3 steps until the cover evenly touches the gear case, then tighten the 8 mm bolts to the specified torque in a crisscross pattern in two or more steps.

Next, tighten the 10 mm bolts to the specified torque.

Make sure that the gears rotate smoothly without binding.

Install the dust guard plate and tighten the bolt securely. Install the collar.

Install the drive shaft (see page 15-8).

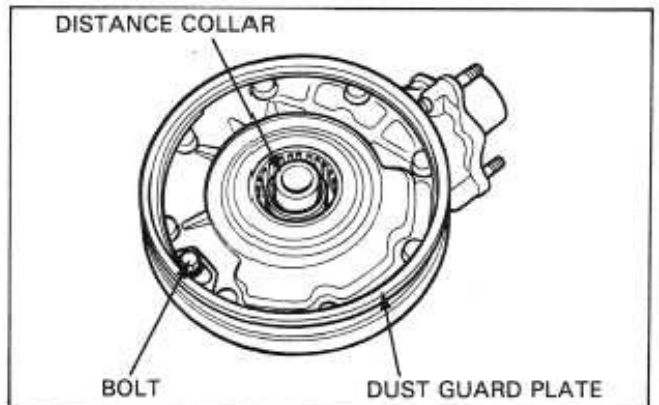

Apply molybdenum disulfide grease to the splines of the drive shaft.

Insert the drive shaft into the universal joint, and attach the gear case to the swing arm with the mounting nuts.

After installing the wheel, tighten the gear case mounting nuts to the specified torque.

Fill the final drive with the specified type and amount of oil.

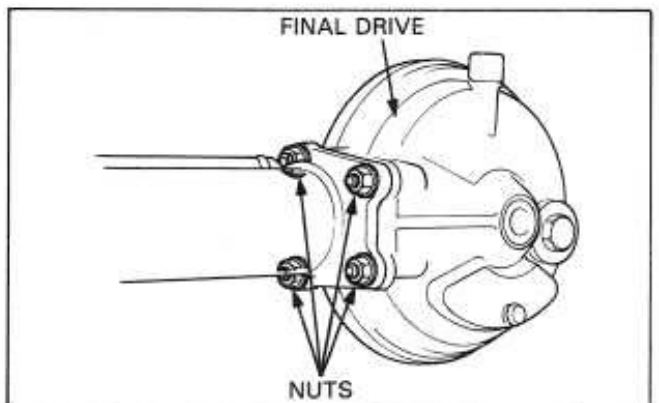

MEMO

16. WHEELS/TIRES

SERVICE INFORMATION	16-1	TIRE REMOVAL	16-13
TROUBLESHOOTING	16-1	TIRE INSTALLATION	16-16
WHEEL REMOVAL/INSTALLATION	16-2	WHEEL BALANCING	16-19
WHEEL BEARING REPLACEMENT	16-10	ATV WHEEL/TIRE	16-19
BASIC TIRE INFORMATION	16-11		

SERVICE INFORMATION

- Support the motorcycle on its center stand and/or with a jack or other suitable support under the engine or frame when servicing the front wheel. Be certain that the motorcycle is secure before proceeding.
- In case the motorcycle, scooter or ATV is equipped with tubeless tires, valves, and wheel rims, use only tires marked "TUBELESS" and tubeless valves on rims marked "TUBELESS TIRE APPLICABLE." Never mount tires designed for use on automobiles.

▲ WARNING

- Any attempt to mount passenger car tires on a motorcycle rim may cause the tire bead to separate from the rim with enough explosive force to cause serious injury or death.

TROUBLESHOOTING

Hard steering

- Steering adjustment nut too tight
- Faulty steering stem bearings
- Damaged steering stem bearings
- Insufficient tire pressure*
- Faulty tire*

Front wheel wobbling

- Bent rim*
- Worn front wheel bearings*
- Faulty tire*

Steers to one side or does not track straight

- Unevenly adjusted right and left shock absorbers
- Bent fork
- Bent front axle: wheel installed incorrectly
- Faulty steering stem bearings
- Bent frame
- Worn wheel bearing(s)*
- Worn swingarm pivot

Wheel turns hard

- Misadjusted brake
- Faulty wheel bearing(s)*
- Faulty speedometer gear*

16

*These items are addressed in this section. All other items are addressed in the Front or Rear Suspension, or Brake Section.

WHEEL REMOVAL/INSTALLATION

FRONT WHEEL

▲WARNING

- Grease on the brake linings will reduce stopping power. Keep grease off the brake linings. Wipe excess grease off the cam and anchor pin.
- Inhaled asbestos fibers have been found to cause respiratory disease and cancer. Never use an air hose or dry brush to clean brake assemblies. Use an OSHA-approved vacuum cleaner or alternate method approved by OSHA, designed to minimize the hazard caused by airborne asbestos fibers.

- Raise the vehicle off the ground by placing a jack or other support under the engine.
- The speedometer cable and front brake cable must be disconnected.
- On vehicles with hydraulic disc brakes, if the wheel cannot be removed with brake caliper(s) installed on the fork legs, remove the wheel after removing the brake caliper with the caliper bracket attached.
- After installing the wheel, check that it turns smoothly and without binding.

AXLE NUT TYPE

Removal:

Remove the axle nut.

Pull the axle from the fork legs while holding the wheel, then remove the wheel.

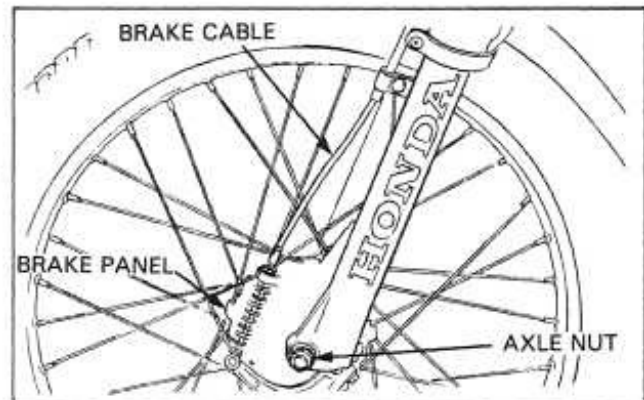

Installation

Drum brake: Align the speedometer gearbox retainer tabs with the cutouts and install the brake drum on the wheel hub.

Install the side collar.

Coat the axle with a small amount of grease.

Place the wheel between the fork legs while aligning the boss on the fork leg with the groove in the brake panel. Insert the axle through the fork legs.

Turn the front wheel so that the speedometer gear retainer will engage properly with the wheel hub.

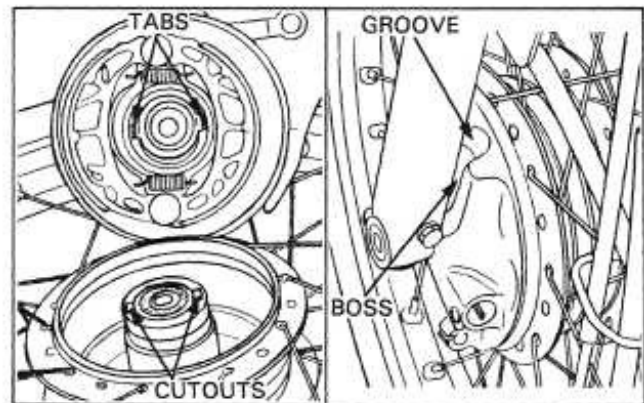

Hydraulic disc brake: Align the stop on the speedometer gearbox with the boss on the fork leg.

Set the wheel so that the brake disc is positioned between the brake pads. Use care not to damage the brake pads. Install the axle.

Tighten the axle nut to the specified torque. (Refer to the Model Specific manual.)

Connect the cables.

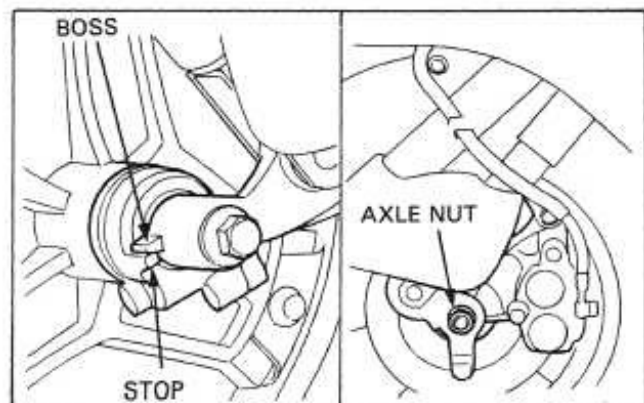

SINGLE HOLDER TYPE

Removal:

Loosen the axle holder nuts.

Loosen the axle while holding the wheel. Remove the axle.

Remove the wheel.

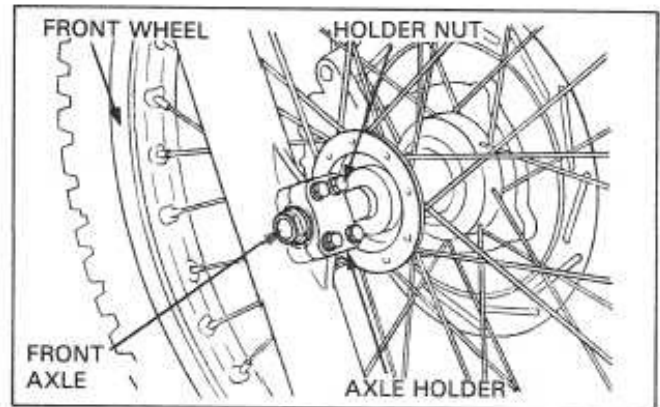

Installation

Hydraulic brake:

Place the front wheel between the fork legs while slipping the disc between the pads. Take care not to damage the pads. Position the wheel in place and insert the axle through the wheel.

Loosely install the axle holder with its UP mark facing up and tighten the axle to the specified torque.

With the front brake applied, pump the front suspension up and down several times, then tighten the holder nuts to the specified torque.

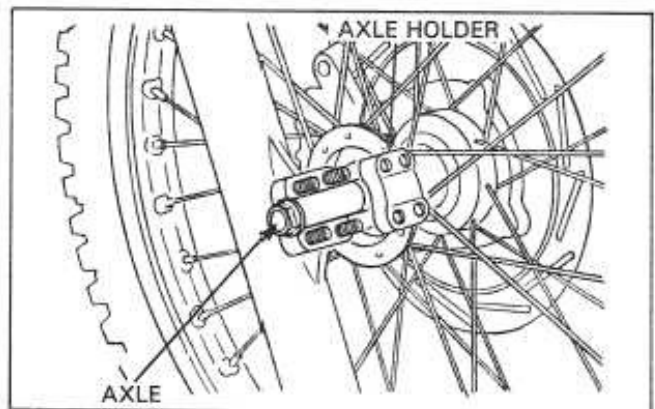

NOTE

- The holder nuts should be tightened:
 On vertically split type: upper first, then lower nut.
 On horizontally split type: front first, then rear nut.

Reconnect the cables.

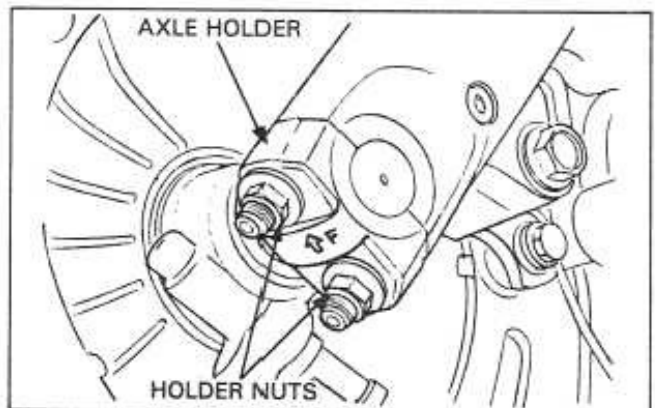

DOUBLE HOLDER TYPE

Removal

Remove the holders from both sides and then remove the front wheel.

Disassembly

Remove the axle nut from the axle, then remove the axle, collar and speedometer gear.

Assembly

Install the side collar and speedometer gear box onto the wheel hub.

Coat the axle with small amount of grease and install the axle. Tighten the axle nut to the specified torque.

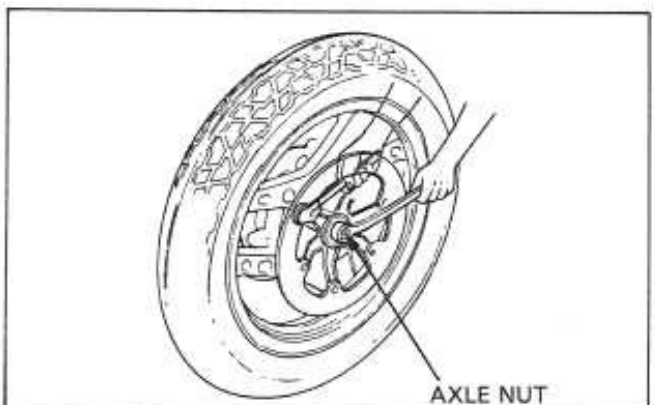

WHEELS/TIRES

Installation

Place the front wheel between the fork legs.

Set the brake disc between the brake pads carefully. Do not damage the pads.

Slowly lower the front of the vehicle until the fork legs are aligned with the axle.

Install the axle holders with the arrow pointing forward and the speedometer gear box boss aligned with the fork leg stop.

Tighten the upper nuts or forward nuts first; then the lower or rear nuts.

Reconnect the cables.

PINCH BOLT TYPE

Removal

Loosen the axle pinch bolts on the axle bolt side and remove the axle bolt.

Loosen the axle pinch bolts on the opposite side and remove the axle while holding the wheel. Remove the front wheel.

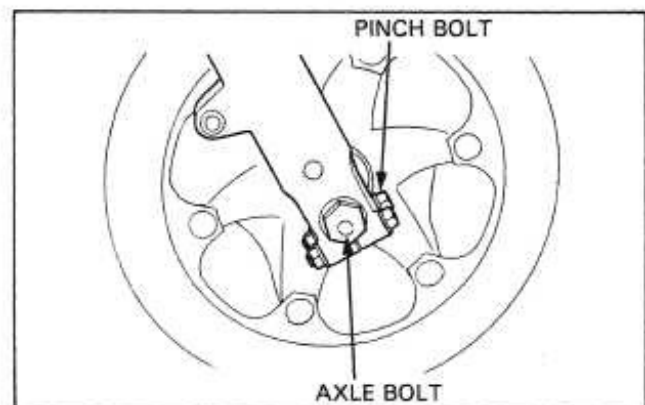
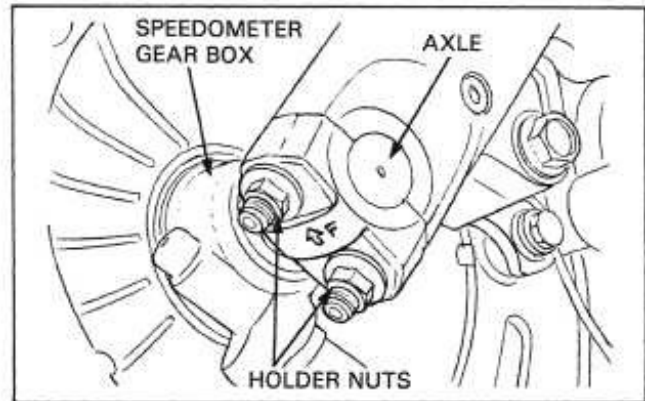

Installation

Place the front wheel between the fork legs and work the brake disc between the pads. Be careful not to damage the pads.

Install the axle. Tighten the axle bolt to the specified torque. Align the speedometer gear box stop with the fork leg stop.

NOTE

- Make sure that the index line on the axle aligns with the fork leg surface.

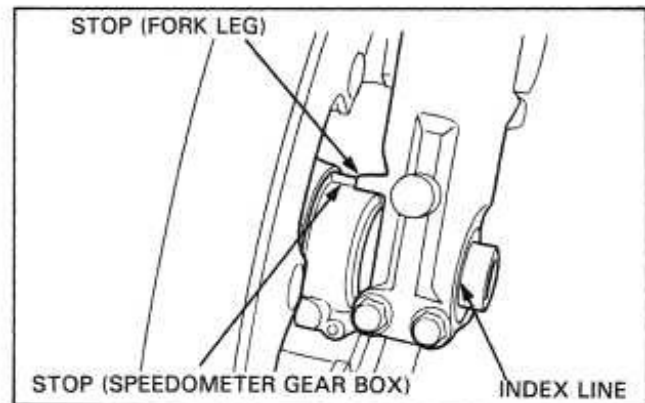

Tighten all the pinch bolts to the specified torque.

Refer to the Model Specific manual for the proper torque values.

Check the clearance between the brake disc and the caliper bracket on each side after installation. The clearance should be at least 0.7 mm (0.03 in).

If the clearance is not 0.7 mm (0.03 in) or more, loosen the holder nuts or pinch bolt on the axle shaft side and adjust the clearance. Then tighten the holder nuts or pinch bolt to the specified torque.

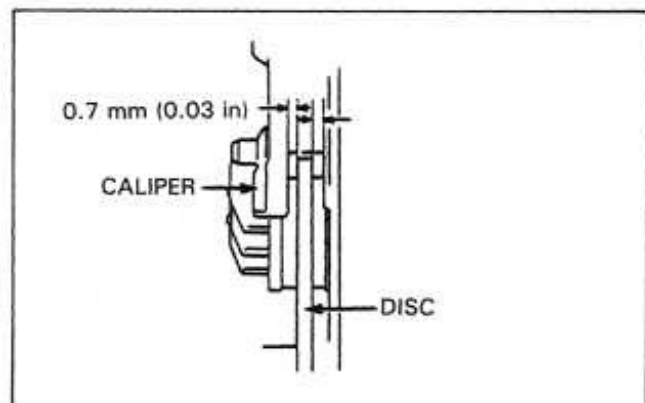

REAR WHEEL

▲WARNING

- Grease on the brake linings will reduce stopping power. Keep grease off the brake linings. Wipe excess grease off the cam and anchor pin.
- Inhaled asbestos fibers have been found to cause respiratory disease and cancer. Never use an air hose or dry brush to clean brake assemblies. Use an OSHA-approved vacuum cleaner or alternate method approved by OSHA, designed to minimize the hazard caused by airborne asbestos fibers.

- Support the vehicle securely with the rear wheel off the ground.
- Remove the muffler and/or other parts necessary to gain access to the wheel.
- For drum brakes, disconnect the brake rod or cable and the brake torque rod from the brake panel.
- For hydraulic disc brakes, it may be necessary to remove the brake caliper. Refer to the Model Specific manual.
- Note the side collar position and direction so it can be installed properly.
- After installing the wheel, make sure that it turns smoothly and without binding.

CHAIN DRIVEN TYPE

Removal

Loosen the axle nut and the drive chain adjusters.

Move the rear wheel forward, and disengage the drive chain from the driven sprocket.

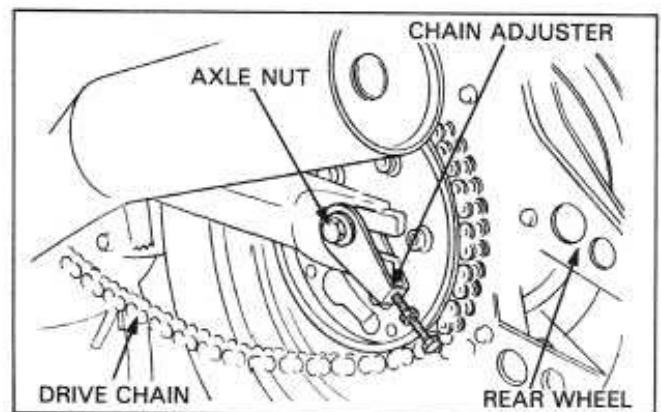

For mechanical drum brakes, remove the rear brake adjusting nut and depress the pedal to disconnect the brake rod (or cable) from the brake arm. If a brake torque rod is mounted on the brake panel, disconnect the torque rod from the brake panel by removing the torque rod mounting nut.

Remove the axle nut and the rear axle.

For hydraulic disc brakes, move the caliper assembly away from the disc to avoid interference.

Remove the rear wheel.

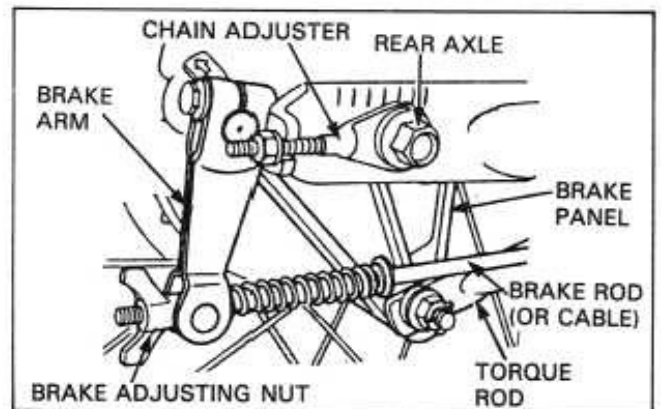

Installation

For drum brakes, install the brake panel and side collar on the wheel hub.

NOTE

- Be sure the collar is installed properly.

Place the rear wheel into the swingarm while laying the drive chain between the sprocket and wheel hub.

If there is no brake torque rod, insert the stop on the swingarm into the groove in the brake panel when installing the wheel into the swingarm.

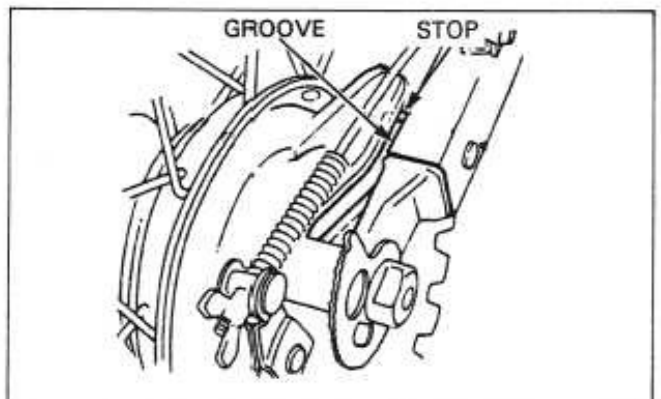

WHEELS/TIRES

For hydraulic disc brakes, install the rear wheel by working the brake disc between the brake pads. Be careful not to damage the pads.

With the rear wheel in place, install the axle with the chain adjuster.

NOTE

- On snail cam types, note the proper direction of the chain adjuster.

Install the chain adjuster and axle nut on the opposite side of the wheel.

Fit the drive chain over the driven sprocket.

For mechanical drum brakes, connect the brake rod (or cable) to the brake arm and install the adjusting nut loosely. If applicable, connect the torque rod to the brake panel and tighten the torque rod nut to the specified torque.

Adjust the drive chain slack.

Tighten the rear axle nut to the specified torque.

Secure the axle nut and torque rod nut with a new cotter pin if required.

For mechanical drum brakes, adjust the rear brake pedal free play.

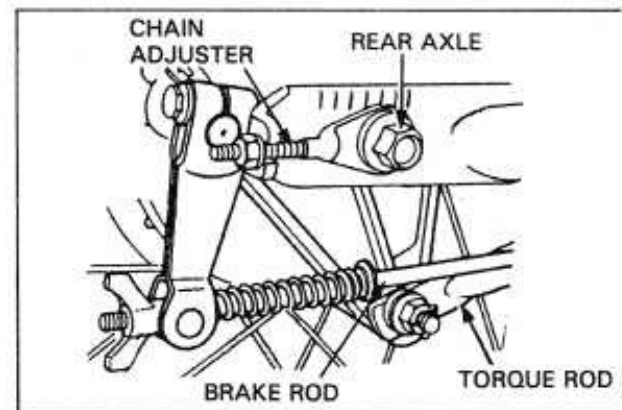
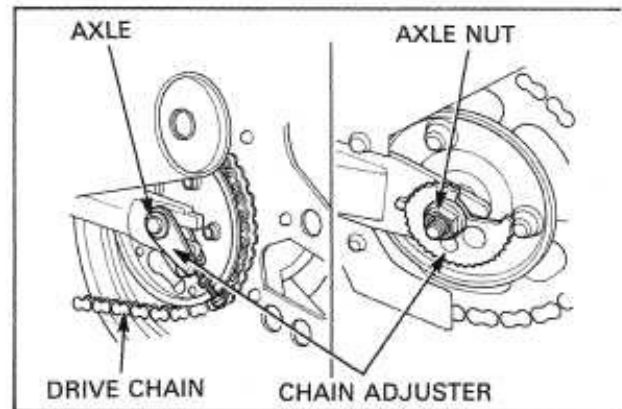

SHAFT DRIVEN TYPE

Removal

For drum brakes, disconnect the brake rod (or cable) and torque rod from the brake panel.

Remove the axle nut and loosen the axle pinch bolt.

Remove the rear axle.

For hydraulic disc brakes, move the caliper assembly away from the disc to avoid interference.

Remove the side collar and pull the rear wheel from the final drive gear. Remove the rear wheel.

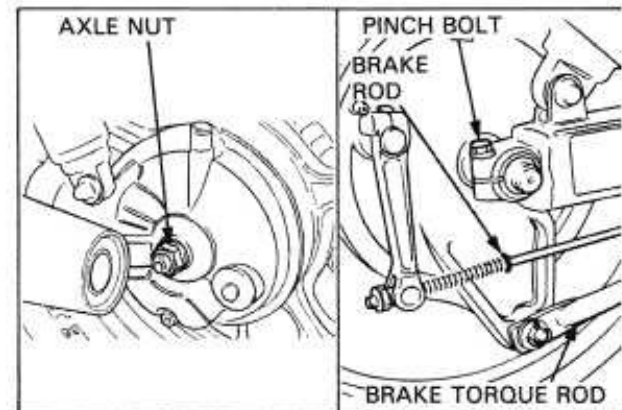

Installation

Coat the driven flange with molybdenum disulfide grease. Install the brake drum onto the wheel hub.

Place the rear wheel into the swingarm.

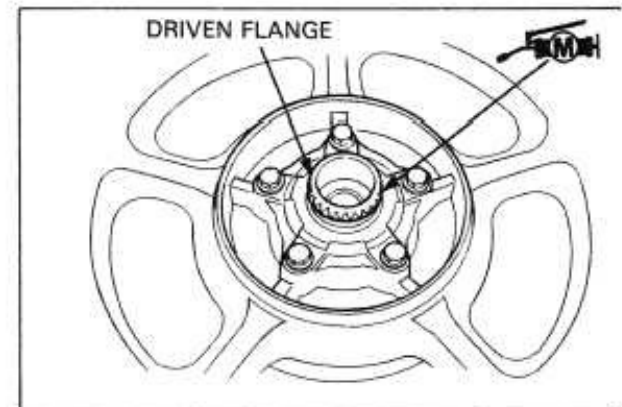

For hydraulic disc brakes, work the brake disc between the brake pads. Be careful not to damage the pads.

Align the splines of the driven flange with the splines of ring gear and push the rear wheel onto the final drive gear.

Install the side collar.

NOTE

- Be sure the collar is installed properly.

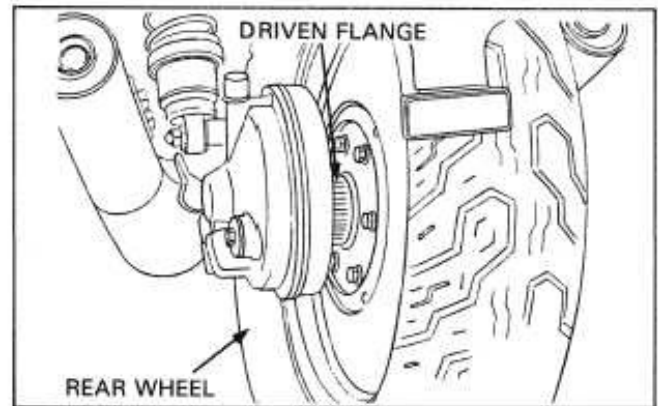

Install the axle.

For mechanical drum brakes, connect the brake rod (or cable) to the brake arm and install the adjusting nut loosely. Connect the torque rod to the brake panel and tighten the torque rod nut to the specified torque.

Tighten the axle nut first, then tighten the axle pinch bolt to the specified torque.

For mechanical drum brakes, adjust the rear brake pedal free play.

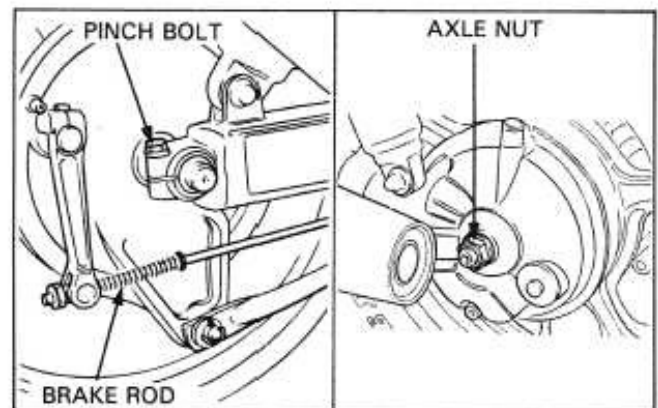

UNIT SWING TYPE

Removal

Remove the frame covers and exhaust muffler if necessary.

Apply the rear brake and loosen the axle nut.

NOTE

- If the rear axle spins with the axle nut, apply torque to the wrench allowing the scooter to tilt rearward and the rear wheel to contact the ground.

Remove the axle nut and the rear wheel.

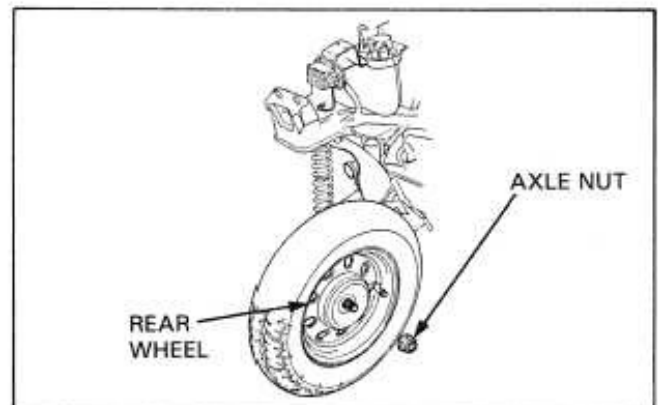

Installation

Install the rear wheel by aligning the splines of the wheel hub with the final drive shaft splines.

Apply the rear brake and tighten the rear axle nut to the specified torque.

NOTE

- If the rear axle spins with the axle nut, apply torque to the wrench allowing the scooter to tilt rearward and the rear wheel to contact the ground.

Install the removed parts.

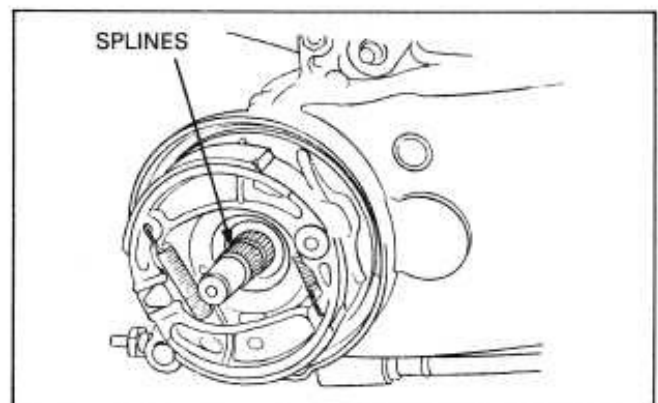

WHEELS/TIRES

PRO-ARM TYPE (CENTER LOCK TYPE)

Removal

Remove the cotter pin.

NOTE

- Do not reuse cotter pin.

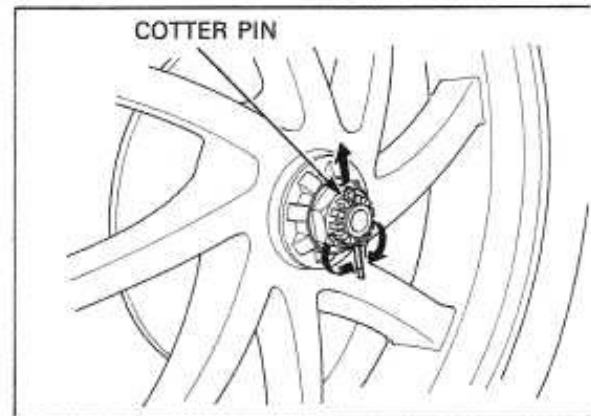

Set the rear wheel to touch the ground and loosen the wheel nut applying the rear break.

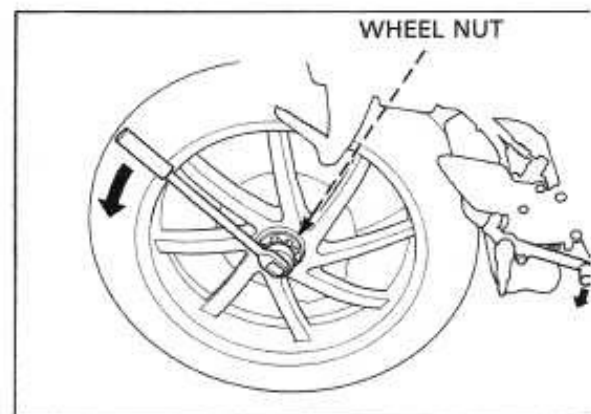

Using the main stand or equivalent, lift the rear wheel. Remove the wheel nut, washer (if equipped), center lock spacer and rear wheel.

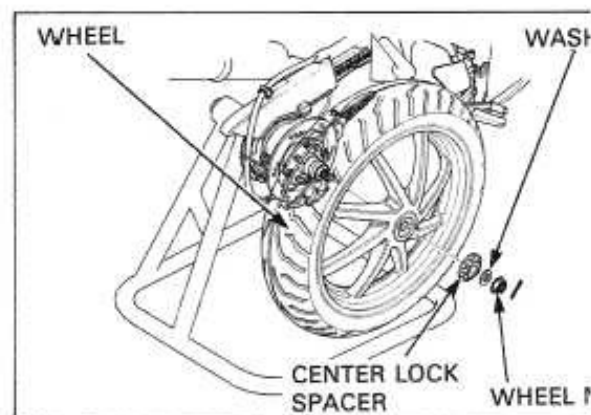

Installation

Check the drive pin hole for damage and crack and clean the contact surface of the rear wheel to the rear axle.

Apply grease to the axle center lock spacer and the contact surface of the rear wheel.

Install the rear wheel aligning the drive pin hole and the wheel center hole.

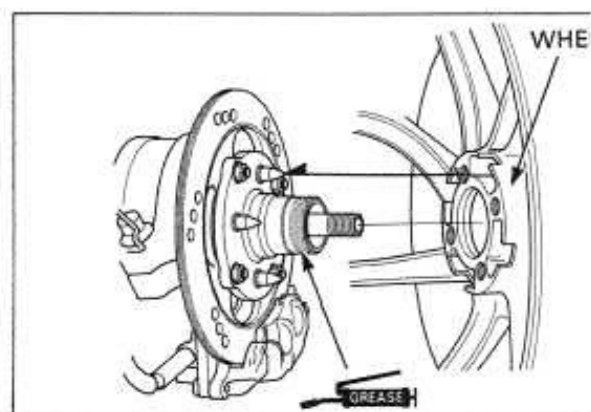

Install the center lock spacer, washer (if equipped) and axle nut.

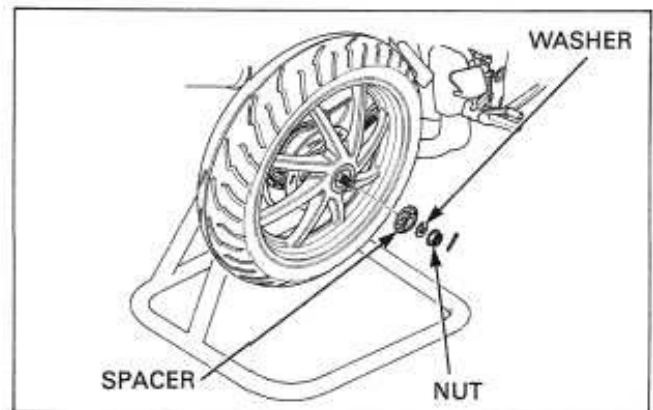

Set the rear wheel to touch the ground and tighten the wheel nut to the specified torque applying the rear break.

Tighten the axle nut to align a groove of the nut to the hole of the axle (to enable to insert the cotter pin).

NOTE

- Aligning of the groove and the pin hole should be done in the tightening direction.

Install the new cotter pin and fold the end to lock the axle nut. (page 1-14)

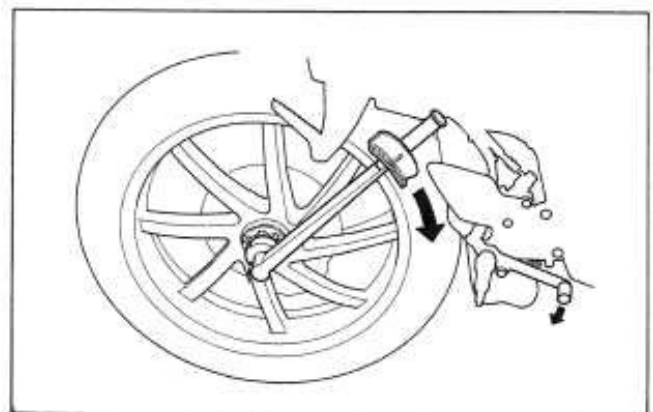

AXLE INSPECTION

Set the axle in V-blocks. Rotate the axle and measure the runout using a dial indicator.

The actual runout is 1/2 of the total indicator reading. Replace the axle if the service limit is exceeded. (Check the Model Specific manual for the specified service limit.)

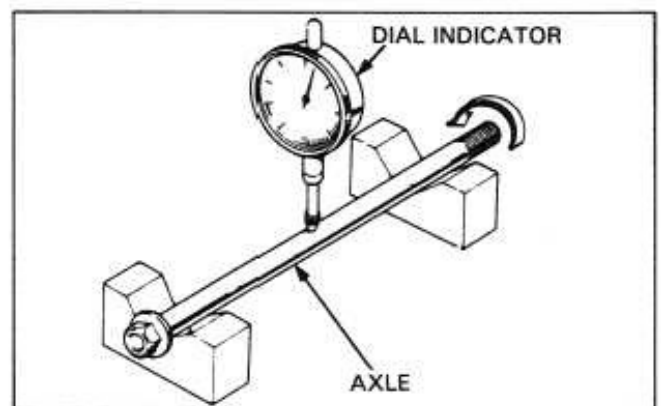

WHEEL BEARING REPLACEMENT

NOTE

- Disc brake type: Be sure to remove the brake discs before removing the wheel bearings.
- Refer to the table on page 1-16 for information on bearing remover/driver size.

REMOVAL

Remove the wheel.

Remove the dust seal, side collar, brake drum, and speedometer gearbox retainer.

Rear wheel:

Chain drive type: Remove the driven sprocket.

Shaft drive type: Remove the driven flange.

Remove the right and left wheel bearings with the bearing remover shaft and remover head.

INSTALLATION

NOTE

- Right and left bearings have a specific installation order. Refer to the Model Specific manual for which bearing to install first.

Drive in a new bearing.

Check the distance collar for the proper installation direction and install the collar.

Install the other bearing.

NOTE

- Replace right and left bearings in pairs. Do not re-use old bearings.
- Single side sealed bearings: Install the bearing with the sealed side facing out.
- Fully sealed bearings: Install the bearing with its stamped size mark toward the outside.

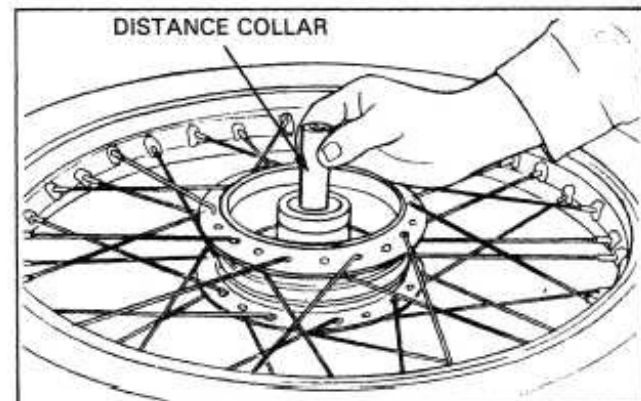
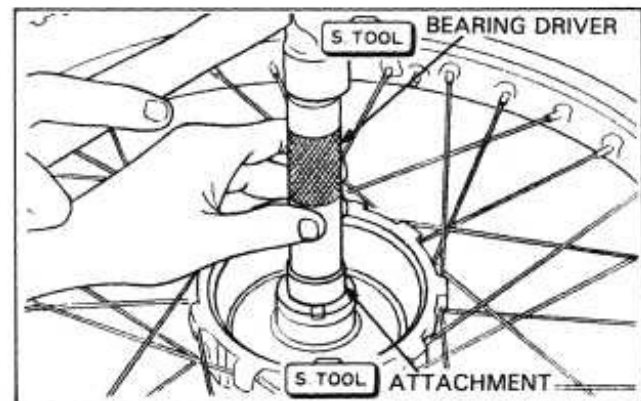
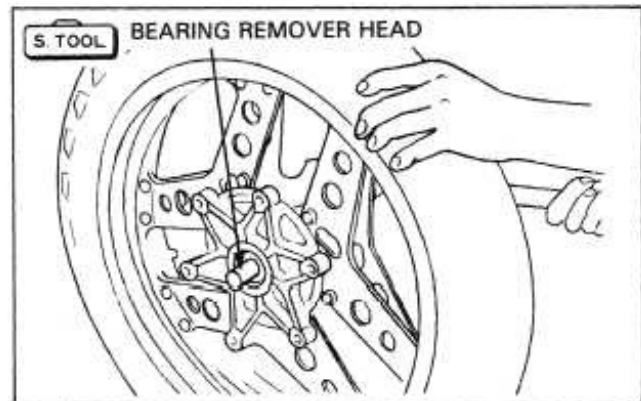

BASIC TIRE INFORMATION

CAUTION

- Be careful not to damage the rim area when using tire mounting tools.

TUBED-TIRE

This type uses an air-filled tube within the tire's casing. Air pressure drops instantly when a nail or other sharp object penetrates the tire and tube.

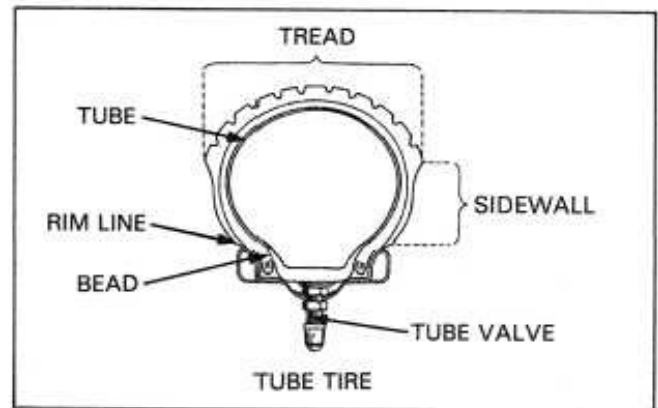

TUBELESS TIRE

In place of a tube, tubeless tires have an inner liner bonded to the inside of the tire. The liner has a special bead area which, together with a wide-grooved bead seating rim, provides an effective seal against pressure loss.

Since the thick liner is not separate from the tire, it does not stretch when inflated and will not burst if punctured. Instead, the liner closes around the puncturing object to prevent substantial pressure loss.

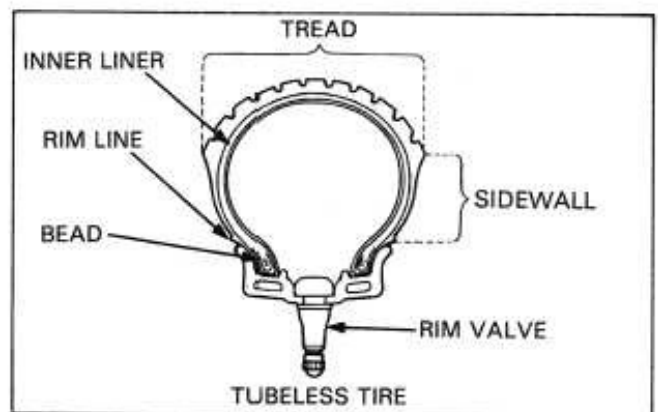

TIRE CODE

[Inch indication]

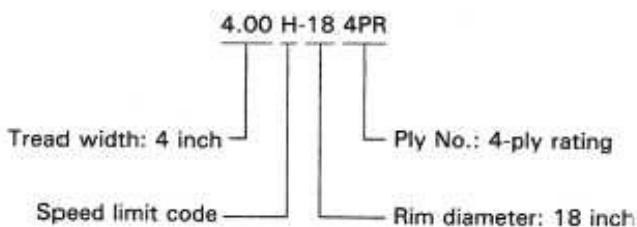

Speed limit code:

- [J] ... 100 km/h max.
- [N] ... 140 km/h max.
- [P] ... 150 km/h max.
- [S] ... 180 km/h max.
- [H] ... 210 km/h max.
- [V] ... 210 km/h min.
- [ZR] ... 240 km/h min.

[Metric indication]

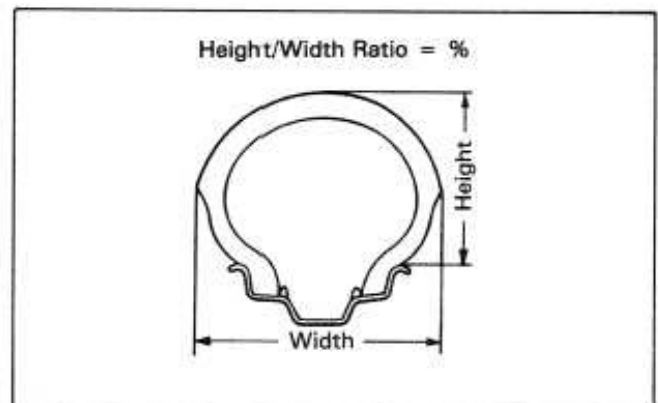
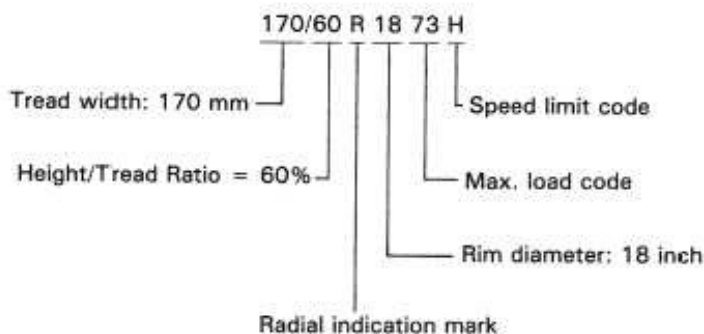

WHEELS/TIRES

Tubeless Tire

⚠ WARNING

- Any attempt to mount passenger car tires on a motorcycle rim may cause the tire bead to separate from the rim with enough explosive force to cause serious injury or death.

Tubeless tires have "TUBELESS" stamped on the sidewalls. Tubeless tire rims have "TUBELESS TIRE APPLICABLE" stamped on them. Each rim valve has "Snap-in valve; TR 412" (or TR413) on it. The rim, bead seating areas, and rim valves are different from tube-types in construction.

Be careful to protect the sealing surfaces when handling and storing tubeless tires and rims.

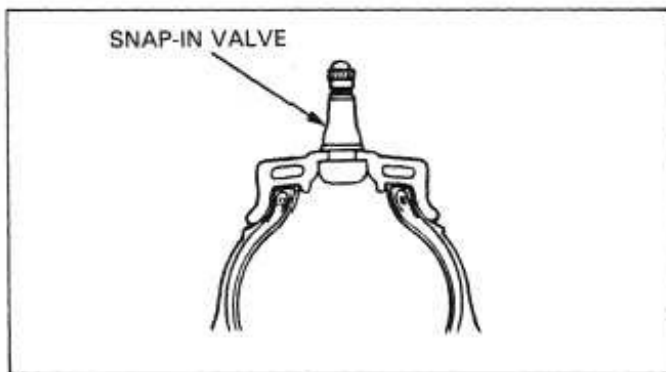

	Tubeless tire rim	Tube tire rim
Identification	 "TUBELESS TIRE APPLICABLE" stamped	"TUBELESS TIRE APPLICABLE" not stamped
Rim valve hole diameter	11.5 mm	8.5 mm

Storage

Store tubeless tires upright with a spacer or thick paper placed between the beads.

If the bead-to-bead clearance is narrower than the rim width, it will be difficult to mount the tire.

Do not stack or lean tires against each other.

To store the a mounted, pressurized tire, adjust the pressure to 1/2 of the recommended amount. Be sure that valve cap is securely installed.

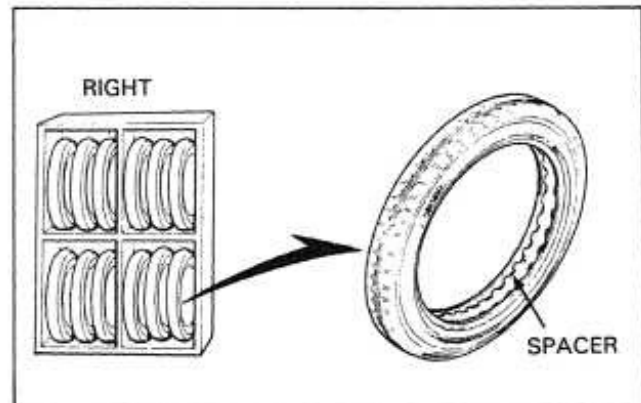

Do not store tubeless tires or rims in these areas:

- Where ozone is produced (near a motor or battery changer)
- In high heat areas (near a heater, steam pipe, etc.)
- Where oil or grease is stored
- In direct sunlight
- In wet or humid areas

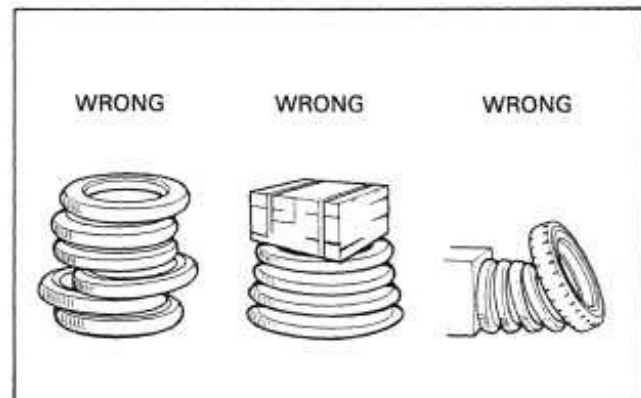

TIRE REMOVAL

Refer to page 16-19 for ATV wheel/tire servicing.
Remove the wheel.

NOTE

- Single brake disc wheels: To prevent damage to the disc, place the wheel on a level surface with the disc facing up.
- Double brake disc wheels: Remove one disc first, then place the wheel on a level surface with the other disc facing up.

Remove the valve cap and bleed air by depressing the valve core.

Remove the valve core after bleeding the air completely.

Remove the valve stem nut and push the valve stem lightly.

If a bead stopper is installed, loosen the lock nut and push the bead stopper down.

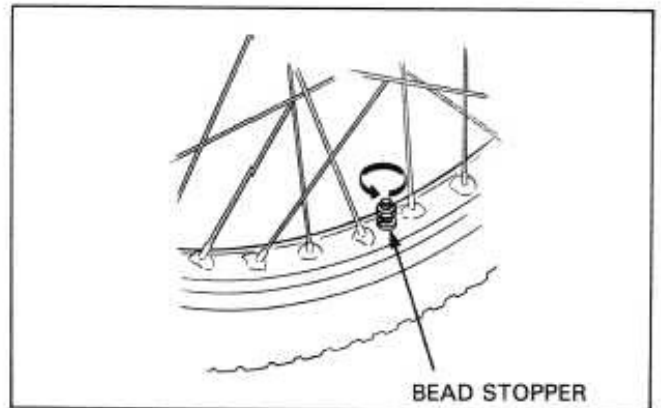
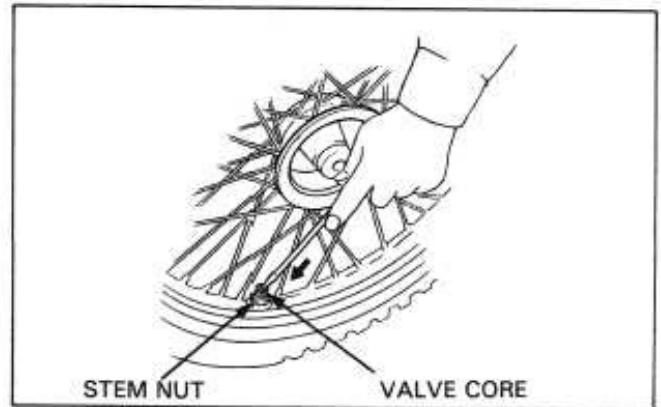

Collaps-in the bead with a tire bead breaker.

If no tire bead breaker is available, step on the sidewall to collapse the bead.

NOTE

- Do not step on the rim.

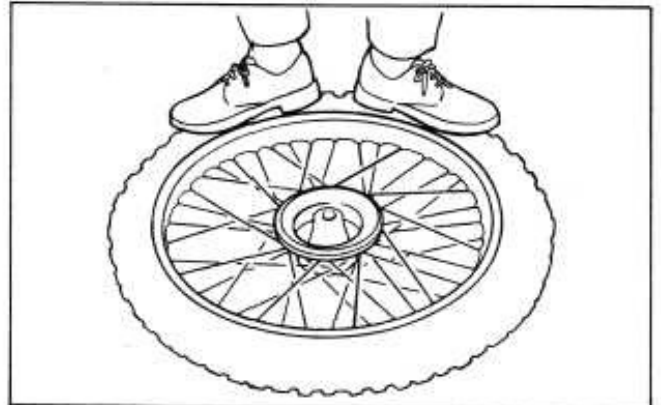

Work the bead into the rim center and slide the tire out of position.

NOTE

- The tire can be removed easily once the beads are collapsed completely.

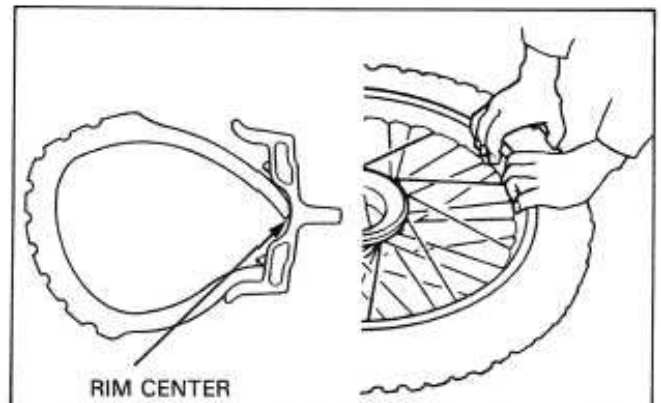

WHEELS/TIRES

Lubricate the rim and tire mating surfaces with water.

Be sure that the bead is completely collapsed. Install a rim protector on the rim.

With tubed tires, insert the tire lever from the opposite side of the valve and raise the bead over the rim.

With tubeless tires, insert the tire lever from the valve side and raise the bead over the rim.

CAUTION

- To avoid damaging the rim when using the tire lever, always use rim protectors.

NOTE

- Be sure to use motorcycle tire levers.
- Do not apply any form of tire mounting lubricant to the rim or tire mating surfaces. Use water only.

Insert another tire lever 30–50mm (1 to 2 in) from the first one and raise the bead over the rim, little by little.

NOTE

- Do not try to raise the bead too much at one time.
- Do not pry against or scratch the bead stopper area with the tire lever.

Repeat the above procedures until half of the bead is removed, then remove the remaining bead by hand.

Tube-type tire only

Press the valve into the rim hole completely and remove the tube from the tire.

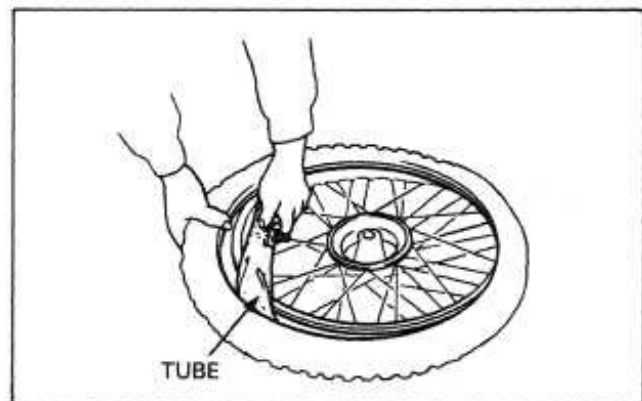
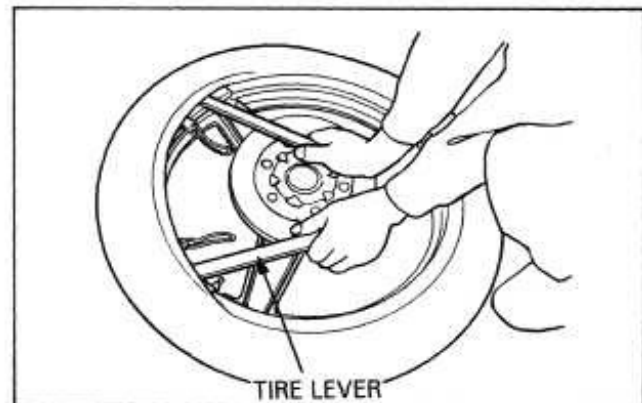
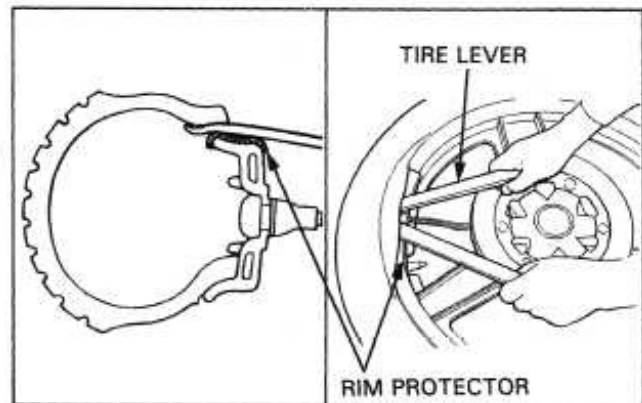
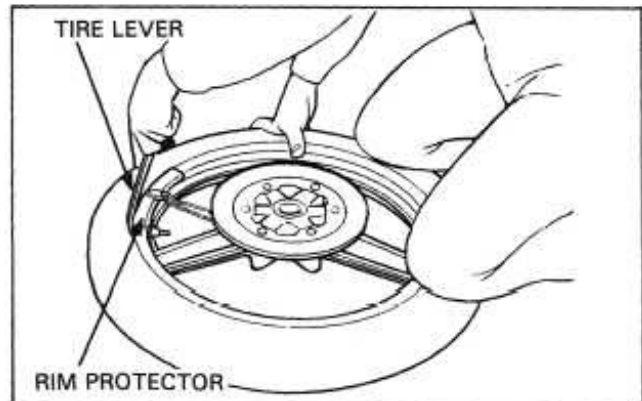

Remove one side of the bead using same procedures as described for tubeless tires.

Remove the tire from the rim.

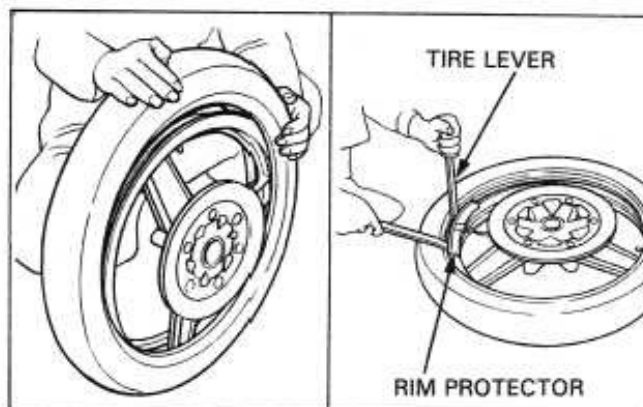

RIM VALVE REPLACEMENT (TUBELESS TIRE ONLY)

Cut off the rim valve at its base.

Apply mild detergent solution to a replacement valve and insert it from inside of the rim.

NOTE

- Be sure to use the recommended rim valve.
- Do not damage the valve hole.
- Replace the rim valve whenever installing a tubeless tire.

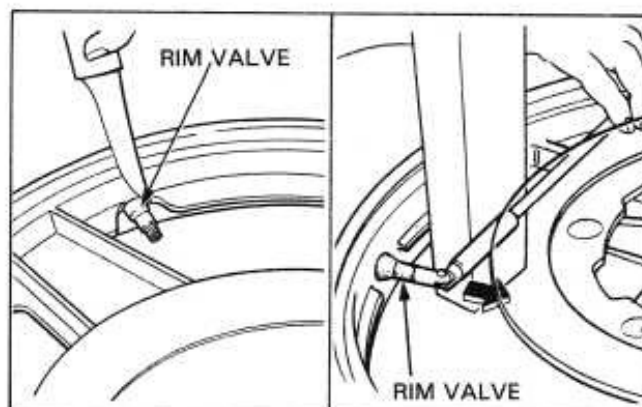

WHEEL CENTER ADJUSTMENT (SPOKE WHEEL ONLY)

The wheel center adjustment is necessary when spoke wheel has been rebuilt.

The distance indicated is as follows:

A: Between the rim side and the surface standard

B: Rim width (measurement)

C: Between the rim center and the surface standard

NOTE

- Refer to the Model Specific manual for the surface standard and the specific value of "C"

Measure distance B (rim width), and make the following calculations.

$$A = C - B/2$$

Example: (B: 76.2mm, C: 56.5mm)

$$A = 56.5 - 76.2/2 = 18.4$$

Adjust the rim position and distance A by tightening the spokes to the specified torque in 2 or 3 progressive steps.

Inspect and adjust the wheel rim runout.

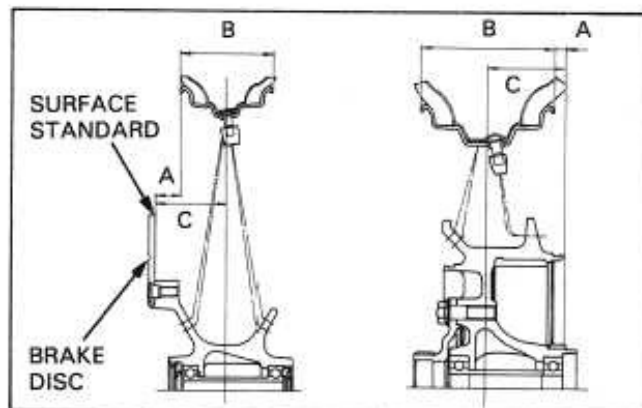

TIRE INSTALLATION

Refer to page 16-17 for ATV's wheel tire servicing.

For a tubed tire, check the rim band and rim lock to be sure they are installed properly.

▲ WARNING

- Any attempt to mount passenger car tires on a motorcycle rim may cause the tire bead to separate from the rim with enough explosive force to cause serious injury or death.

CAUTION

- Always replace rims which have been bent or have cracks, as they may cause air leakage.
- Always replace the rim if there are any flaws over 0.5mm deep or 1.0mm wide on the bead contact surface.

Check the overall condition of tire.

Use only water as a lubricant when removing or mounting tires. Soap or other tire lubricants may leave a slippery residue that can cause the tire to shift on the rim.

▲ WARNING

- A tire that shifts on the rim may lead to a sudden loss of air pressure while riding and an accident could occur.

NOTE

- Be sure to use motorcycle tire levers and rim protectors.

If the tire has a balance dot (paint mark), install the tire with this mark aligned with the valve.

If the tire has rotation direction arrow, install the tire with the mark pointing in the direction of rotation.

Stand the tire upright, hold it with one hand and, starting from the side opposite the valve, install one side of the tire on the rim as much as you can by hand.

Be sure to assemble in the sequence shown.

Place the wheel on a level surface and install the remaining portion of the bead using two tire levers.

NOTE

- To aid in assembly, apply water to the tire and rim mating surfaces.
- Do not apply any form of tire mounting lubricant to the rim or tire mating surfaces. Use water only.

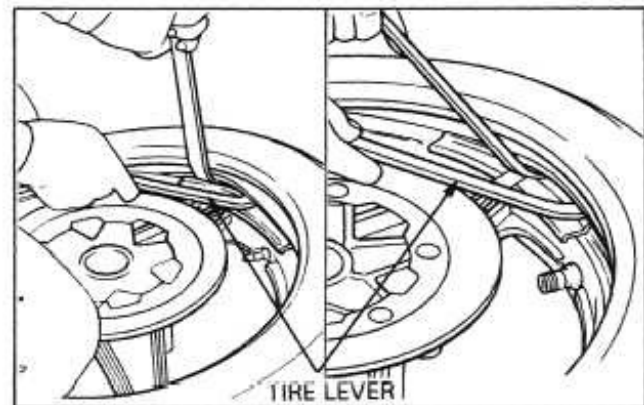
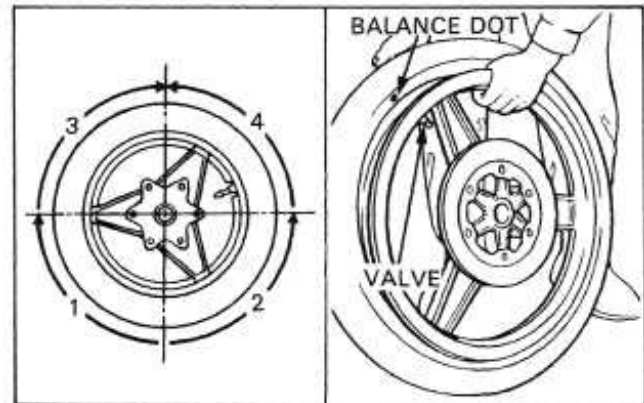
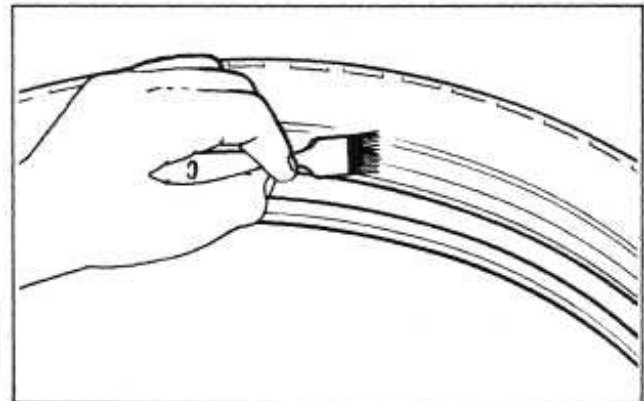
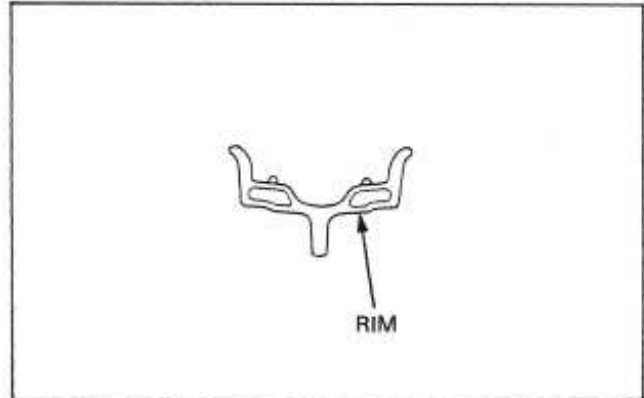

Tubed tires only

Inflate the tube with a small amount of air and push into the tire.

Insert the valve through the rim valve hole and loosely install the stem nut.

Work the tube by hand until it is seated evenly in the rim center.

Be sure that the tube is not twisted and the valve stem is straight.

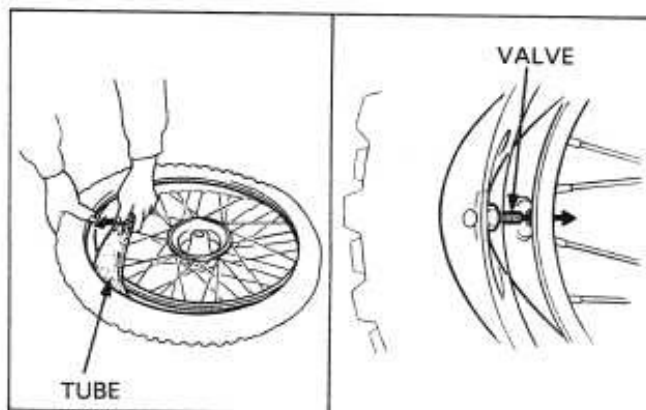

Install the bead on the other side of the tire while holding the assembled portion of the bead with your knee to prevent it from coming off.

NOTE

- Before using the first tire lever, be sure that the bead on the opposite side is positioned in the center of the rim.

Install the bead a little at a time, using care not to damage the tube or the rim with the tire lever.

After 1/2 of the bead has been installed, insert the second tire lever at a distance of 30–40 mm (1 to 2 in) from the first. Continue working the bead under the rim with the levers in this proximity until 3/4 of the bead has been installed.

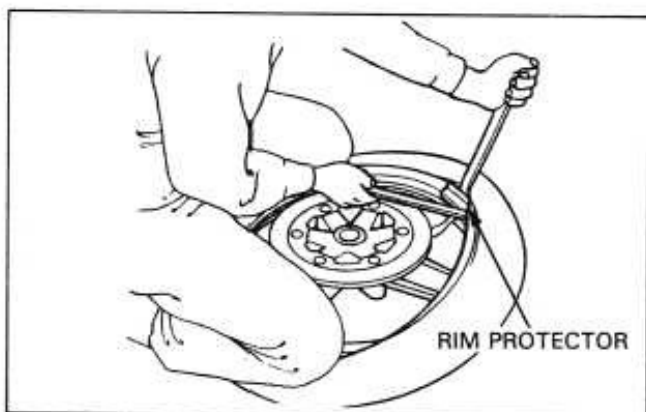

NOTE

- Hold one tire lever upright to remove the other lever.

After 3/4 of the bead has been installed, check the bead on the opposite side. Be sure it is still in the center of the rim.

NOTE

- The last portion of the bead is more difficult to install. The rim and bead may be damaged if the bead on the opposite side of the point where you are working is not in the rim center.

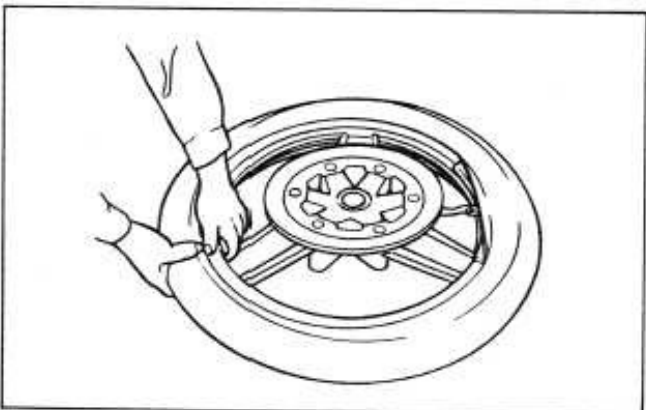

When only 50–60 mm (2 to 2.5 in) of the bead remains free, pull the two levers up and over.

NOTE

- It is important to align the balance dot (paint circle or spot) with the valve stem. The balance dot indicates the lightest portion of the tire. Alignment with the valve stem minimizes the weight needed to balance the wheel and tire.

Install the valve core.

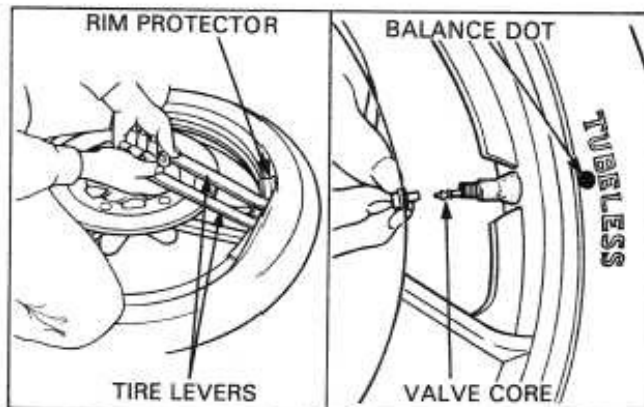

WHEELS/TIRES

Use only water as a lubricant when removing or mounting tires. Soap or other lubricants may leave a slippery residue which can cause the tire to shift on the rim.

▲ WARNING

- A tire that shifts on the rim may lead to a sudden loss of air pressure while riding and an accident could occur.

Tap on the tire tread surface with a rubber hammer so that the tire and rim fit evenly around the circumference.

Be sure that the tire center and rim center are aligned.

Inflate the tire to 1.5 times the standard recommended pressure to seat the bead on the rim.

▲ WARNING

- Use the tire pressures specified in the Model Specific manual or on the tire label. Overinflation may cause a tire to burst with sufficient force to result in serious injury or death.

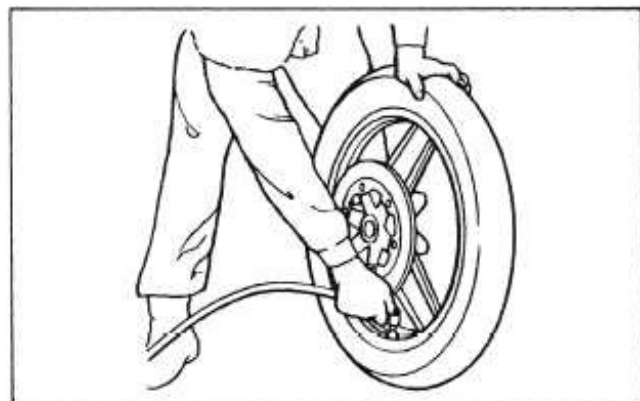
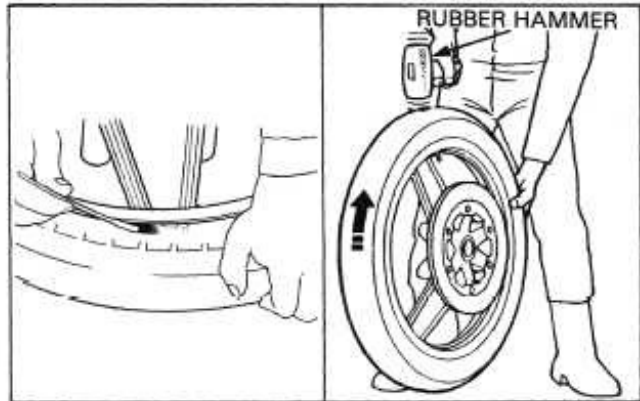

NOTE

- For tubeless tires, you may hear a loud sound as the bead seats onto the rim. This is normal.
- For tubeless tires, if air leaks out from between the rim and bead, let the wheel stand with the valve at the bottom and increase air pressure while pushing down on the tire.

Check that the tire bead seats on the tire rim securely and the rim line of the tire is concentric with the rim.

Adjust the tire pressure to the specified pressure.

Check the wheel balance.

Tighten the rim lock nut to specified torque (if available).

Tighten the valve stem nut (on tubed tires).

Install the wheel.

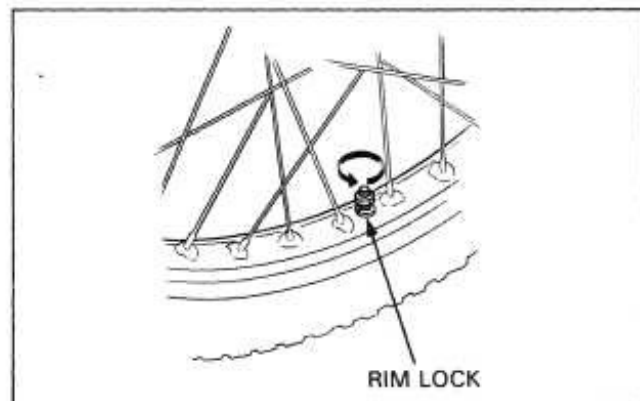
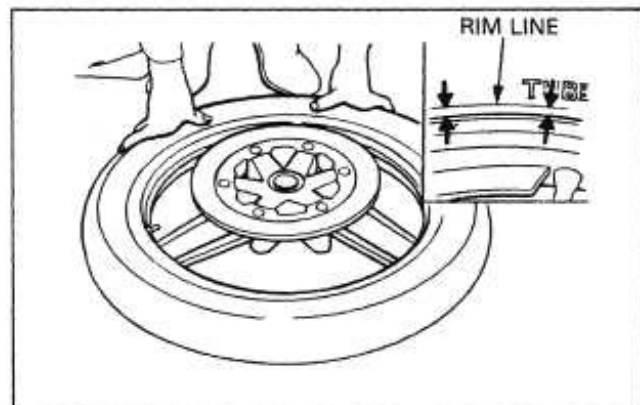

WHEEL BALANCING

Refer to the Model Specific manual to determine if the model being serviced requires wheel balancing. The manual will specify the type of weights required, if necessary.

▲ WARNING

- **Wheel balance directly affects the stability, handling and overall safety of the motorcycle. Carefully check balance before reinstalling the wheel.**

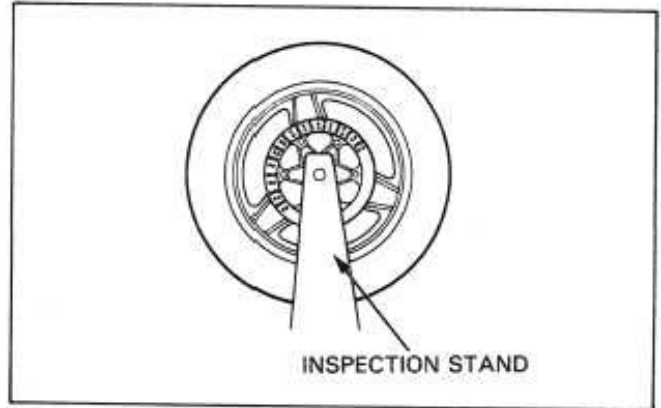

Mount the wheel, tire and brake disc assembly in an inspection stand.

Spin the wheel, allow it to stop, and mark the lowest (heaviest) part of the wheel with chalk. Do this two or three times to verify the heaviest area. If the wheel is balanced, it will not stop consistently in the same position.

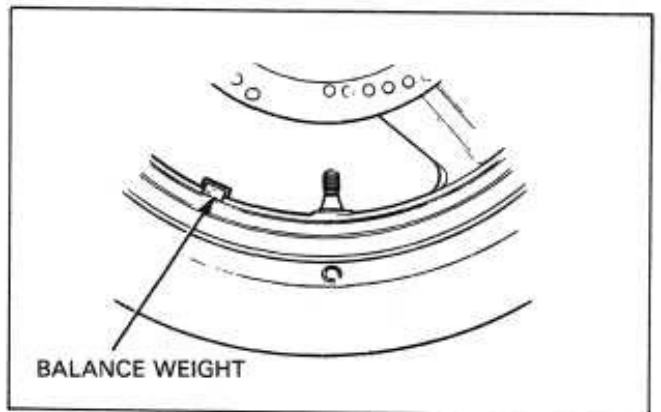

To balance the wheel, install wheel weights on the lightest side of the rim, the side opposite the chalk marks. Add just enough weight so the wheel will no longer stop in the same position when it is spun.

ATV WHEEL/TIRE

REMOVAL/INSTALLATION

Loosen the wheel nuts.

Raise the rear wheels off the ground by placing a jack or block under the engine.

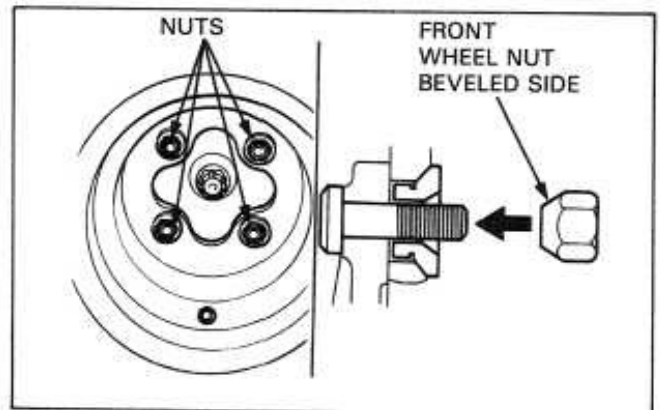

Remove the wheel nuts and wheel.

Install the wheel in its original position.

NOTE

- Do not interchange the right and left tires. If the tire has an arrow mark, install the wheel with the arrow mark pointing in the direction of rotation.

Install the wheel nuts with the beveled sides facing inward and tighten them to the specified torque.

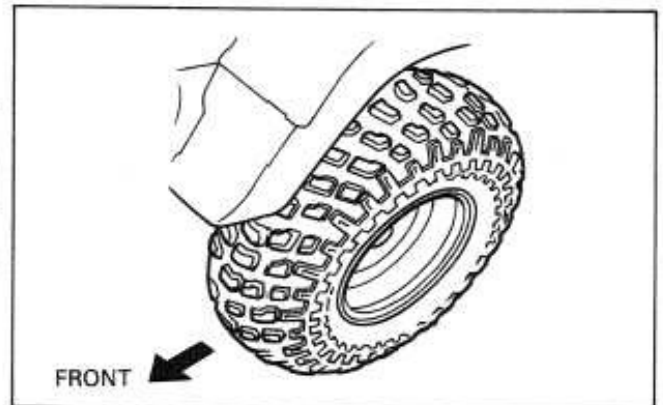

WHEELS/TIRES

TIRE REMOVAL (U.S.A. ONLY)

NOTE

- This service requires the Universal Bead Breaker (GN-AH-958-BB1) available in the U.S.A. only.
- Remove and install tires from the rim side opposite the valve stem.

Remove the core from the valve stem.

A tire bead tool is required for tire removal. Use a Coats 220 Tire Changer or equivalent to remove the tire from the rim. If a tire changer is not available, rim protectors and tire irons may be used.

CAUTION

- Take care to avoid damaging the bead seating area of the rim.

Install the proper size blade for the rim you are working on onto the breaker arm assembly.

CAUTION

- Use of an improper size tire tool may result in damage to the rim, tire, or tool.

Place the proper size adapter onto the threaded shaft and then put the wheel over the threaded shaft and adapter.

Lube the bead area with water, pressing down on the tire sidewall/bead area in several places to allow the water to run into and around the bead. Also lube the area where the breaker arm will contact the sidewall of the tire.

Use only water as a lubricant when removing or mounting tires. Soap or other tire lubricants may leave a slippery residue that can cause the tire to shift on the rim.

⚠ WARNING

- A tire that shifts on the rim may lead to a sudden loss of air pressure while riding and an accident could occur.

While holding the breaker arm assembly at an approximate 45° position, insert the blade of the breaker arm between the tire and rim. Push the breaker arm inward and downward until it is in the horizontal position with its press block in contact with the rim.

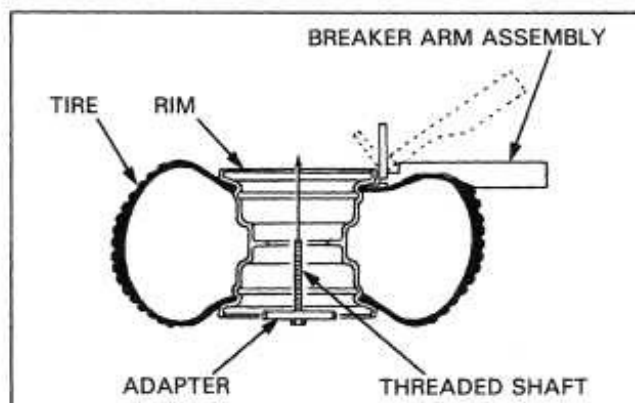
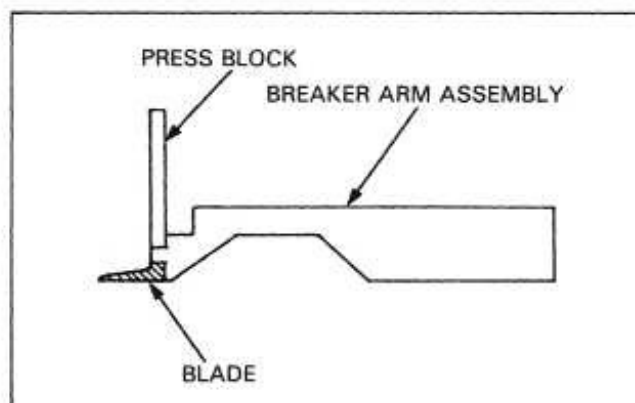

With the breaker arm in the horizontal position, place the breaker press head assembly over the breaker arm press block. Make sure the press head bolt is backed out all the way and then position the nylon buttons on the press head against the inside edge of the rim.

Insert the threaded shaft through the appropriate hole in the breaker press head assembly and then tighten the lever nut until both ends of the breaker press head assembly are in firm contact with the rim.

Tighten the press head bolt until the reference mark on the press block is aligned with the top edge of the press head.

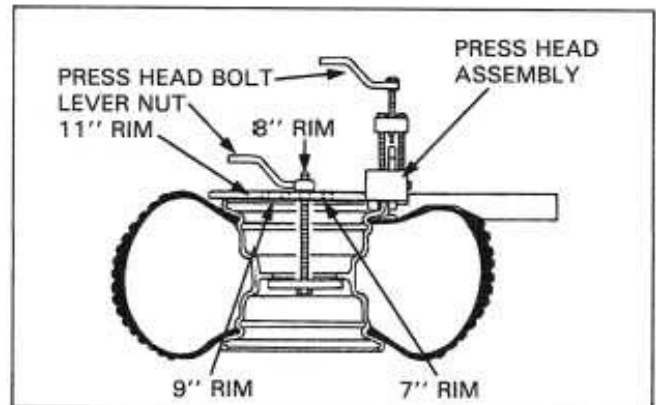

If the rest of the bead cannot be pushed down into the center of the rim by hand, loosen the press head bolt and the lever nut. Rotate the breaker arm assembly and breaker press head assembly 1/8 to 1/4 of the circumference of the rim. Tighten the lever nut and then tighten the press head bolt as described.

Repeat this procedure as necessary until the remainder of the bead can be pushed down into the center of the rim.

Assemble the Universal Bead Breaker on the other side of the wheel and break the bead following the same procedures.

Remove the tire from the rim using a tire changer machine or tire irons and rim protectors.

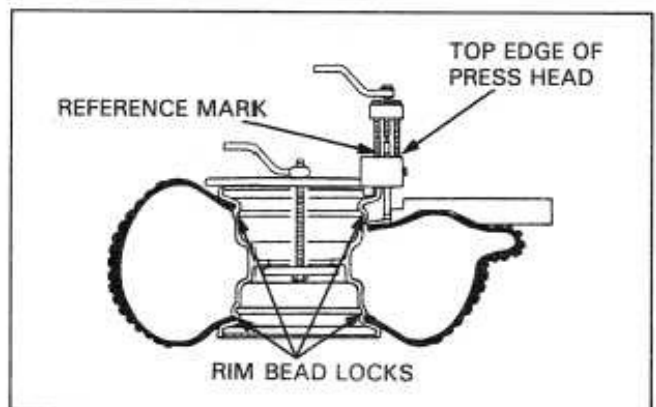

Remove tire from the side of the rim that has the smallest shoulder area to simplify removal.

REMOVAL (EXCEPT U.S.A.)

NOTE

- Applying water, soapy water, oil, or other lubricants to the tire, rim or tire tool when removing the tire may cause the tire breaker arm to slip off the tire so that the bead cannot be broken.
- Follow the breaker manufacturer's instructions.

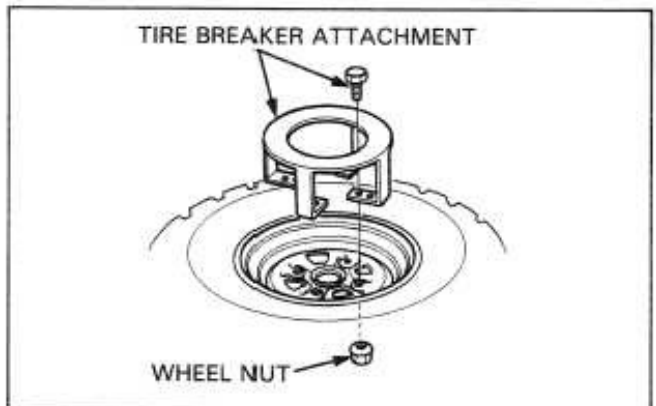

CAUTION

- Do not damage the bead seating area of the rim.

Install the tire breaker attachment on the rim with the wheel nuts and tighten the nuts securely.

Insert the narrow end (A side) of the breaker arm between the tire and the rim.

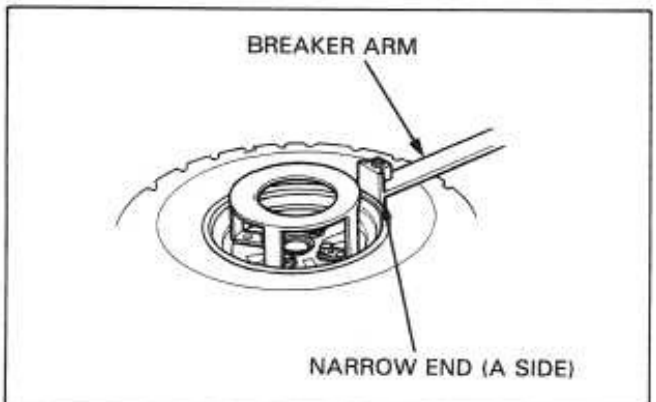

WHEELS/TIRES

Position the breaker arm compressor on the tire breaker attachment as shown.

Keep the breaker arm horizontal and align the end of the compressor bolt with the breaker arm hole.

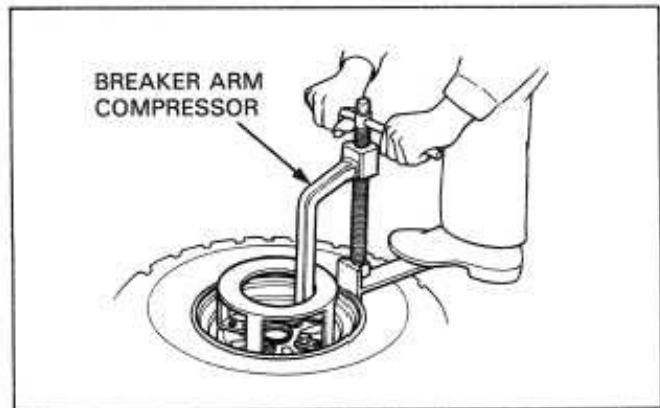

Screw in the breaker arm compressor bolt while pushing the breaker arm on the tire with your foot to break the bead from the rim.

NOTE

- Do not break the bead all at once. Remove and reposition the compressor and arm 1/8 of the circumference of the rim. Tighten the compressor bolt. Break the bead by repeating this procedure 3–4 times.

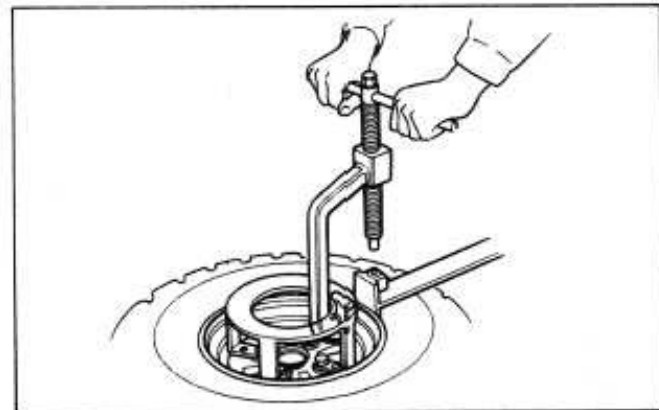

If bead breaking is difficult with the narrow end (A side) of the breaker arm, use the wide end (B side) of the arm and repeat the procedure described above.

After removing the tire from the rim, cut the valve off at the bottom, being careful not to damage the rim.

NOTE

- Be sure to replace the valve with a new one whenever the tire is removed from the rim.

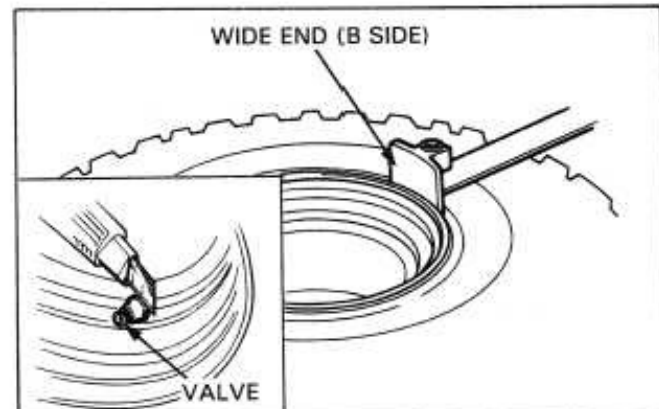

TIRE REPAIR

NOTE

- Use the manufacturer's instructions for the tire repair kit you are using. If your kit does not have instructions, use the procedures provided here.

Check the tire for the puncturing object(s). Chalk mark the punctured area and remove the object.

Inspect and measure the injury. Tire repairs for injuries larger than 15 mm (5/8 in) should be a section repair. Section repairs should be done by a professional tire repair shop.

If the injury is smaller than 15 mm (5/8 in), proceed with the repair as described here.

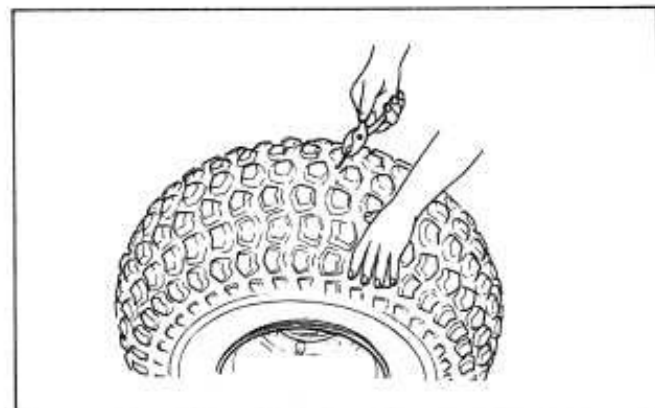

Install a rubber plug into the hole as follows:

Apply cement to a plug inserting needle and work the needle into the hole to clean and lubricate it. Do this three times. Do not let the cement dry.

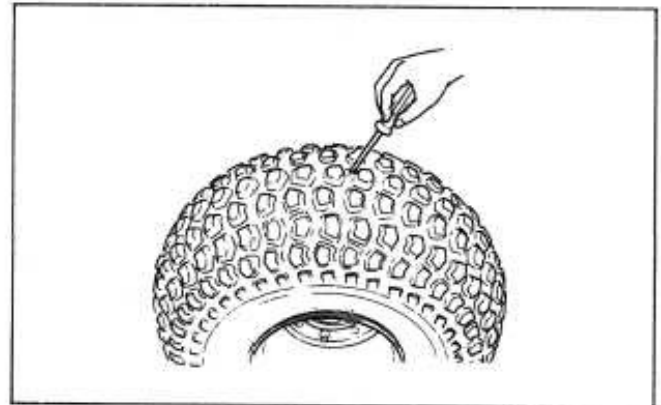

Insert and center a rubber plug through the eye of the inserting needle.

Apply cement to the rubber plug.

Push the inserting needle with plug into the hole until the plug ends are slightly above the tire. Twist the needle and remove it from the tire; the plug will stay in the tire.

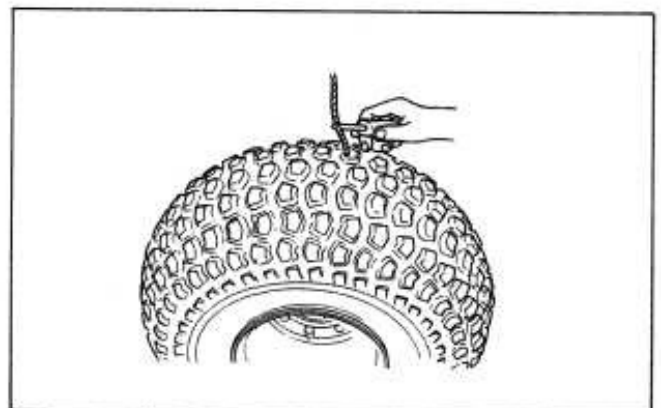

NOTE

- Be careful not to push the plug all the way into the tire.

Trim the plug 6 mm (1/4 in) above the tire surface.

Repeat the above procedure if the puncture is large.

Do not use more than two plugs per hole.

Allow the repair to dry. Drying time will vary with air temperature. Refer to the tire repair kit manufacturer's recommendations.

Inflate the tire and test the seal by dabbing a small amount of cement around the plug. Escaping air will cause a bubble in the cement. If there is leakage, remove the tire (page 16-19) and apply a cold patch to the inside of the tire as described.

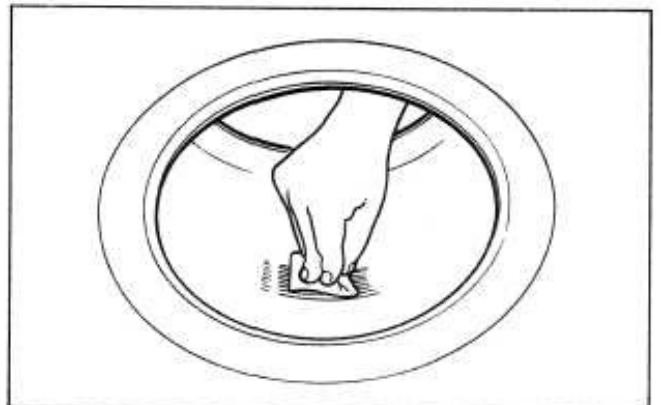

If a plug has been inserted, trim it even with the inner tire surface.

Temporarily place a rubber patch that is at least twice the size of the puncture over the injury. Make a mark around the patch, slightly larger than the patch itself.

Remove the patch.

Roughen the area marked inside the tire with a tire buffer or a wire brush. Clean the rubber dust from the buffed area.

Apply cement over the area marked and allow it to dry.

Remove the lining from the patch and center it over the injury.

Press the patch against the injury using a special roller.

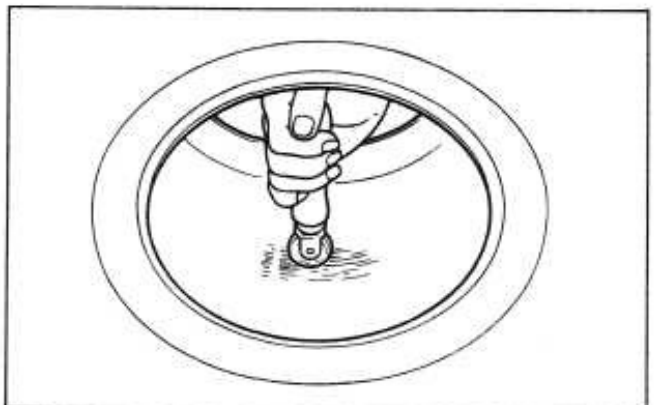

NOTE

- Allow cement to dry until tacky before applying patch.
- Do not touch the cement with dirty or greasy hands.

WHEELS/TIRES

ASSEMBLY

Clean the rim bead seat and flanges.
Apply clean water to the rim flanges, bead seat and base.

Install the tire on the rim, where the rim shoulder width is the narrowest, to simplify installation.

▲ WARNING

- Use only water as a lubricant when mounting tires. Soap or other tire lubricants may leave a slippery residue that can cause the tire to shift on the rim resulting in a sudden loss of air pressure while riding.

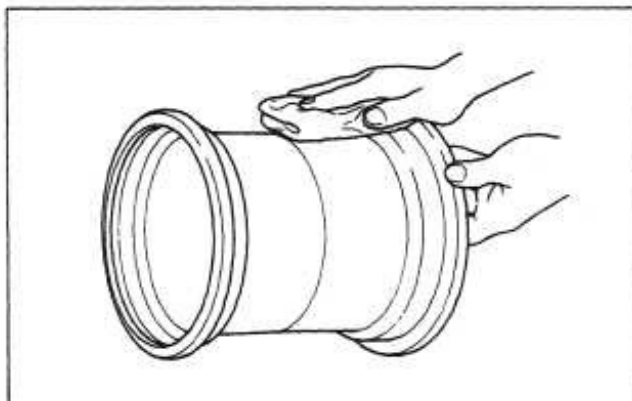

Install the valve core in the valve stem.
Install the tire and inflate it to seat the tire bead.

▲ WARNING

- The maximum pressure for seating the tire bead is indicated on the side wall. Do not inflate the tire beyond this pressure. The tire could burst with sufficient force to cause severe injury.

NOTE

- If the tire has arrow mark, install the tire with the mark pointing in the direction of rotation.
- Do not interchange the right and left tires.

Deflate the tire. Wait 1 hour and inflate the tire to the specified pressure.

Check for air leaks and install the valve cap.

The ATVs are equipped with tubeless tires, valves, and wheel rims. Use only tires marked "TUBELESS" and tubeless valves on rims marked "TUBELESS TIRE APPLICABLE." Never mount tires designed for use on automobiles on an original rim.

17. BRAKES

TROUBLESHOOTING	17-1	HYDRAULIC DISC BRAKES	17-8
BRAKE SYSTEM DESCRIPTIONS	17-2	MECHANICAL DRUM BRAKES	17-16

TROUBLESHOOTING

⚠ WARNING

- Inhaled asbestos fibers have been found to cause respiratory disease and cancer. Never use an air hose or dry brush to clean brake assemblies. In the United States, use an OSHA-approved vacuum cleaner or alternate method approved by OSHA, designed to minimize the hazard caused by airborne asbestos fibers.

HYDRAULIC DISC BRAKE

Brake lever/pedal soft or spongy

- Air bubbles in the hydraulic system
- Leaking hydraulic system
- Contaminated brake pad/disc
- Worn caliper piston seal
- Worn master cylinder piston seal
- Worn brake pad
- Contaminated caliper
- Caliper not sliding properly
- Worn brake pad/disc
- Low fluid level
- Clogged fluid passage
- Warped/deformed brake disc
- Sticking/worn caliper piston
- Sticking/worn master cylinder piston
- Worn brake disc
- Contaminated master cylinder
- Bent brake lever/pedal

Brake lever/pedal hard

- Clogged/restricted brake system
- Sticking/worn caliper piston
- Caliper not sliding properly
- Clogged/restricted fluid passage
- Worn caliper piston seal
- Sticking/worn master cylinder piston
- Bent brake lever/pedal

Brakes grab or pull to one side

- Contaminated brake pad/disc
- Misaligned wheel
- Clogged/restricted brake hose
- Warped/deformed brake disc
- Caliper not sliding properly
- Clogged/restricted brake hose joint

Brakes drag

- Contaminated brake pad/disc
- Misaligned wheel
- Worn brake pad/disc
- Warped/deformed brake disc
- Caliper not sliding properly

17

MECHANICAL DRUM BRAKE

Poor brake performance

- Improperly adjusted brake
- Worn brake linings
- Worn brake drum
- Worn brake cam
- Improperly installed brake linings
- Brake cable sticking/needs lubrication
- Contaminated brake linings
- Contaminated brake drum
- Worn brake shoes at cam contact areas
- Improper engagement between brake arm and cam-shaft serrations

Brake lever hard or slow to return

- Worn/broken return spring
- Improperly adjusted brake
- Sticking brake drum due to contamination
- Worn brake shoes at cam contact areas
- Brake cable sticking/needs lubrication
- Worn brake cam
- Improperly installed brake linings

Brake squeaks

- Worn brake linings
- Worn brake drum
- Contaminated brake linings
- Contaminated brake drum

BRAKES

BRAKE SYSTEM DESCRIPTIONS

Braking systems on motorcycles, like virtually all braking systems, dissipate the vehicles kinetic energy by transforming it into heat energy-known as friction heat.

Two basic types of braking systems are used on Honda motorcycles and scooters; the drum-type and the disc type. Both the drum and the disc rotate together with the wheel. Each is slowed by the friction of either shoes or pads that press against them.

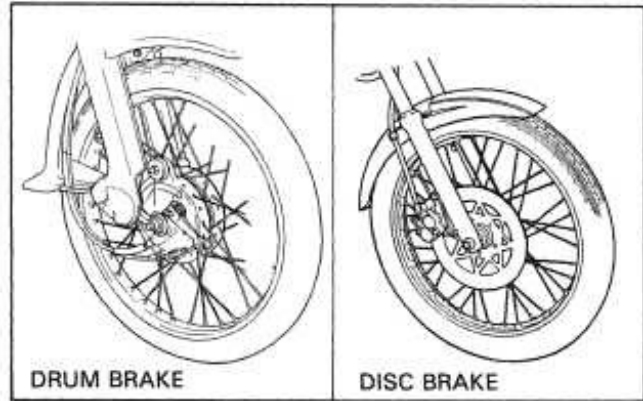

MECHANICAL DRUM BRAKE

Single Leading Shoe Type (Or, Leading-Trailing Shoe Type)

Force applied against the brake lever or pedal activates a cable or rod attached to the brake mechanism. A threaded adjuster on the end of the brake actuating cable or rod offers one of two adjustments to control the precise brake actuation point. The adjuster acts against a pivot on the end of the brake arm, which is clamped onto and turns a brake activating cam.

As shown in the illustration to the right, this cam transfers a rotating force from the outside of the drum, through the protective brake panel to the inside of the drum. Here the cam spreads one end of two crescent-shaped shoes. The other end of the shoes pivot against a common pin set into the brake panel. Both shoes press against the inside surface of the drum, creating friction and slowing the rotation of the wheel. The first shoe to act upon the drum beyond the cam, in relation to the rotating direction of the drum, is called the leading shoe. The second shoe, arcing out against the drum from the common pivot pin, is called the trailing shoe.

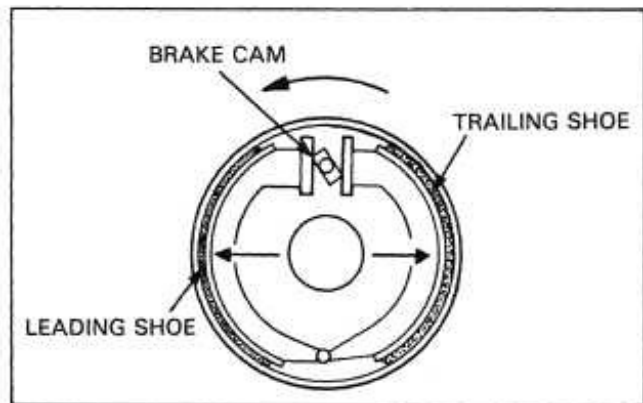

Due to its position within the system, the leading shoe creates more force against the drum than that which is applied to it. This increased force capability is called a self-energizing effect. In contrast, the trailing shoe, again, because of its position within the system based on the rotating direction of the drum, is pushed back by the rotating drum and creates less force than that which is applied to it.

Dual Leading Shoe Type

Dual leading shoe brakes differ from single leading shoe types in that they use two shoe-activating cams, each at opposite ends of the brake panel, to simultaneously press the shoes against the drum (see illustration at the right). Because both shoes are leading in relation to the rotating direction of the drum and therefore operate against the drum in same way, the effective braking force is noticeably greater than a similarly sized single leading shoe unit with an identical amount of actuating force applied to the brake lever or pedal.

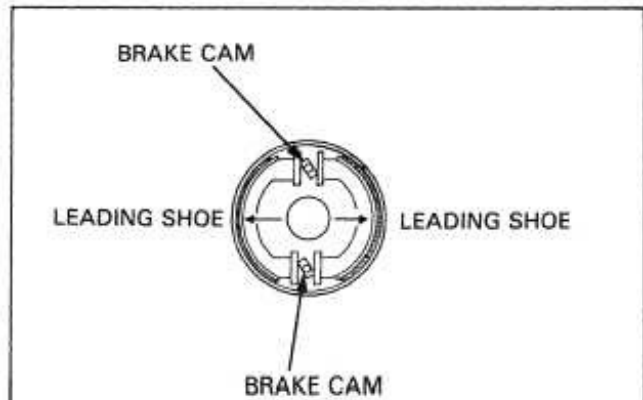

It is vital for brake systems to quickly dissipate the heat that is generated by the friction of the braking action so their stopping force remains consistent. Since drum brakes contain almost all of the brake components within the wheel hub, it is important that these brake components be made of materials that conduct heat rapidly. It is just as important that the brake is of the proper size for the anticipated requirements of the vehicle.

In order to enhance heat conductivity while providing acceptable wear resistance on the inner surface of the brake drum, the drum itself is made of cast iron. The remainder of the drum/hub is made of aluminum alloy with cooling fins cast into the outer circumference; again for heat conductivity and dispersion, but also for reduced unsprung weight. To speed conductivity, the cast iron drum is captured within the aluminum hub and cannot be removed.

The drum thickness is relatively thin, which further aids heat conductivity, and must not be machined in a brake lathe. If the drum surface is severely damaged, the hub must be replaced.

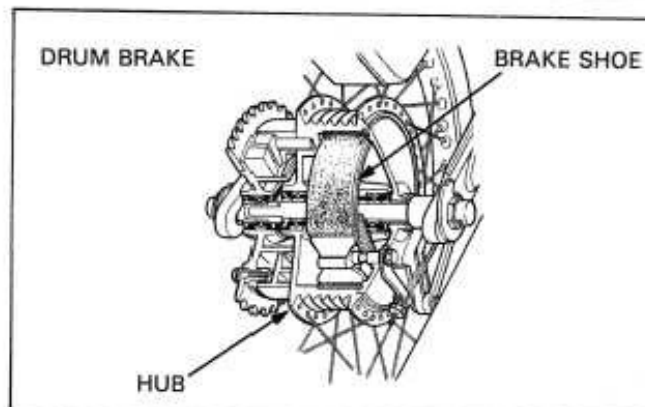

HYDRAULIC BRAKES

Brake Fluid

The designations DOT 3 and DOT 4 specify the brake fluid's ability to withstand heat without boiling. The greater the number, the higher the boiling point. It is necessary for the brake fluid to have a high boiling point so that the fluid does not boil within the brake line due to the high temperature of the brake discs and components. Boiling brake fluid leads to a drastic loss of braking force due to the air bubbles that form within the brake lines.

Never mix DOT 3 and DOT 4 brake fluid within a system. It is important to add only the same DOT number and even the same brand of brake fluid when adding fluid. If you are unsure of the type within the system, drain the system and refill it with DOT 4; systems designed for DOT 3 can use DOT 4. But DOT 4 systems must never be filled with DOT 3. DOT 4 systems generate greater heat and thereby require the higher boiling point characteristic of DOT 4.

Avoid mixing different brands of brake fluid. Improper mixing such as this may lead to chemical decomposition and contamination.

It is also important to use only fresh brake fluid from a sealed container. Once a new container of brake fluid is opened, be sure to reseal it tightly and plan on discarding the fluid after six months. This is because brake fluid left in the container tends to absorb moisture from the air; it is hygroscopic. Moisture can form even within a sealed brake system because of this particular property. Moisture in the brake fluid contaminates the brake system and lowers the boiling point of the fluid. It also corrodes the brake cylinders and pistons, which eventually causes seal damage and leakage.

For this reason you should note the date on the container when it is first opened for later reference.

BRAKES

Never reuse brake fluid due to the possibility of contamination from dust or moisture absorption.

If the brake fluid in a system shows any visual signs of contamination, it should be replaced — even if the recommended replacement interval has not passed.

You must be careful when handling brake fluid because it can quickly damage many painted or plastic surfaces on contact. In certain plastics, structural damage can occur if brake fluid penetrates the material's surface. The only general exception is the components of the brake system that are designed to be resistant to the effects of brake fluid. Brake fluid that is spilled on a motorcycle should be washed away with water immediately.

Before removing the reservoir cover, turn the handlebar until the reservoir is level.

Place a rag over painted, plastic or rubber parts whenever the system is serviced.

CAUTION

- Spilled fluid will damage painted, plastic or rubber parts.

Refill with the same type of fluid from an unopened container. Do not allow foreign material to enter the system when refilling the reservoir.

▲ WARNING

- Using the wrong fluid can cause loss of braking efficiency.
- Contaminated fluid can clog the system, causing a loss of braking ability.

Pressure applied against the brake lever or pedal moves the piston within the master cylinder unit. Hydraulic fluid pressure is then transmitted through the brake line to the caliper where it presses against one or more caliper pistons. Because hydraulic fluid cannot compress, the caliper piston(s) move at the same instant as does the master piston in the master cylinder.

The rise in hydraulic pressure that takes place between the master cylinder and the caliper because of the differences in the diameter of these parts is most significant. During development, these sizes are juggled to achieve best braking force and "feel". The leverage ratio offered by the design of the lever or pedal acting upon the master piston also helps to increase the force to be transmitted to the caliper pistons compared to the force initially applied.

The caliper pistons are in direct contact with the back side of the brake pads. Anti-squeal shims are normally used between the piston and pad. As these pads press against opposite sides of the disc, the rotation of the wheel is slowed.

When the brake lever is released, hydraulic pressure decreases and the pads cease to press against the disc. Unlike drum brake systems where a spring retracts the shoes from the drum surface, on disc brake systems, the resilience of the caliper piston seals retracts the pads from the disc and automatically self-adjust for wear.

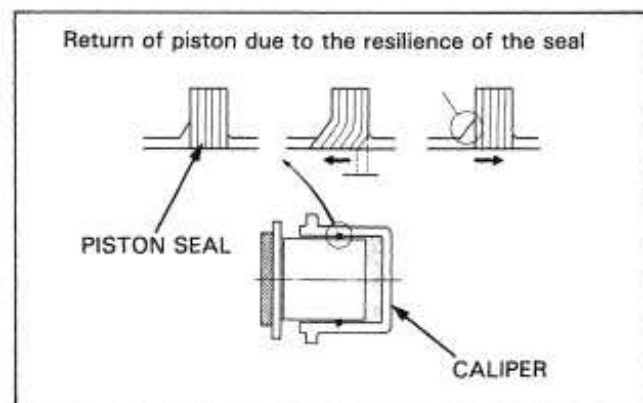
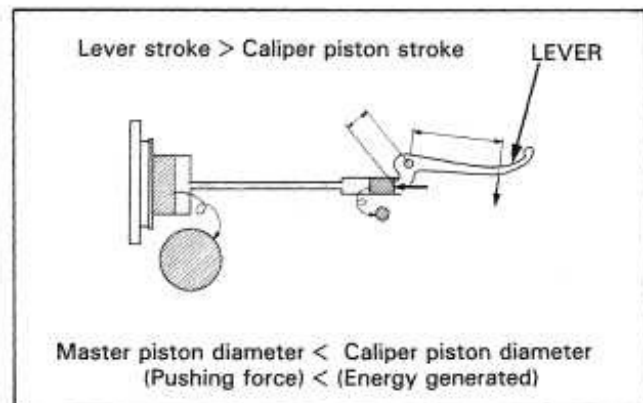

In single push type calipers, both pads press against the brake disc through a reaction of the sliding caliper yoke. Calipers of this type with single piston are more common on earlier Hondas. More current models use a single push type, but with dual pistons (both on the same side).

Opposite piston calipers are most often used for road racing motorcycles today. They do offer some improvement in performance, but at great increase in cost and complexity. In this type, pistons facing each other on opposite sides press the pads against the disc.

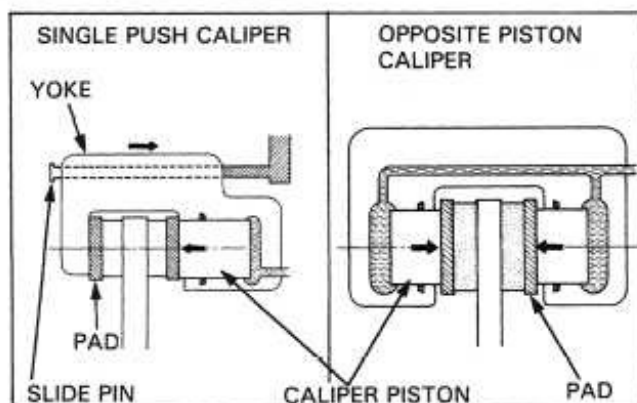

The amount of braking force available depends on the magnitude of force pressing the pads against the discs, the size of the contact area between the brake pads and discs, the distance between the center of the wheel and the center of the brake pads, and on the outside diameter of the tire.

Rectangular brake pads were introduced to increase the area of the pad against the disc. But it was found that these pads do not press against the disc uniformly, so the braking force is not as effective as it could be. Hence, the dual piston caliper was introduced so that a large braking force and uniform pressure against the brake pads is ensured. Some dual piston calipers have different piston sizes to further balance the braking force across the pad — the trailing piston being larger than the leading piston.

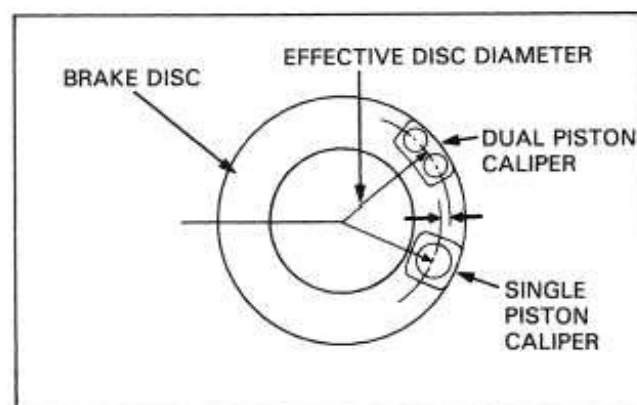

As previously touched on, increasing the area of contact between the brake pads and disc increases the braking force. This increased contact means increased heat energy. The increased heat energy requires greater capability for heat dissipation.

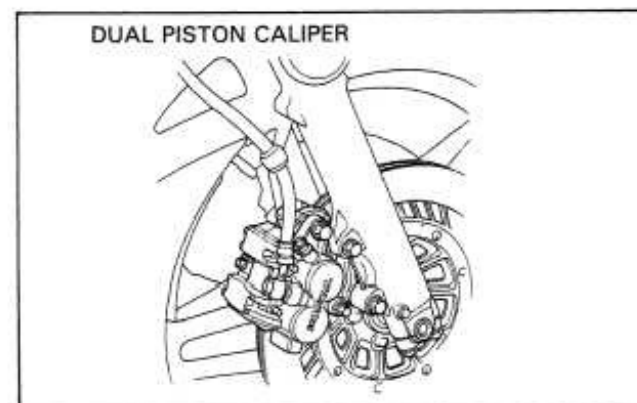

With the exception of in-board disc brakes and the GL1500 front brakes, all brake discs are exposed. To protect them from rust, the discs are made of stainless steel alloy.

Because the material the discs can be made of is limited, the discs can only be made so thin in order to reduce unsprung weight before thermal distortion of the disc becomes a problem.

As the temperature of the brake disc rises, the disc expands. Because the disc is bolted to the wheel, its expansion is limited and some degree of distortion occurs.

The VTR250, with its in-board front disc, uses a plain cast iron disc since rust is not a problem. The design of the GL1500 front brake with its covered discs and calipers, transfers much of its heat to the cast, hollow wheel.

BRAKES

To cope with the extreme heat typically generated in competition road racing, floating type discs have been developed. In this system, a floating disc is installed by means of spring washers and rivets or clevis pins with an aluminum carrier between the disc and the wheel. In this manner, deviations in radial directions are permitted, distortion is prevented and weight is reduced.

In addition to the design basics already stated, discs are commonly drilled or grooved to remove dust or dirt from the disc surface, thereby preventing what are known as sympathetic vibrations. Contrary to popular belief, holes drilled in the disc do not significantly aid cooling. These holes are perpendicular to the flow of air so little additional cooling occurs.

Among the many combinations of materials used to make brake pads are: wear resistant resin, metallic mixtures, and sintered metal. These materials are combined in brake pad manufacturing according to the design requirements of the particular application. Asbestos was dropped from use in pad manufacturing by Honda beginning around 1985-86.

Just as disc brakes are used where greater than typical drum brake stopping force is required, dual disc brakes (a disc on both sides of a single wheel) are used where an even greater braking capability or a smaller diameter front wheel is required.

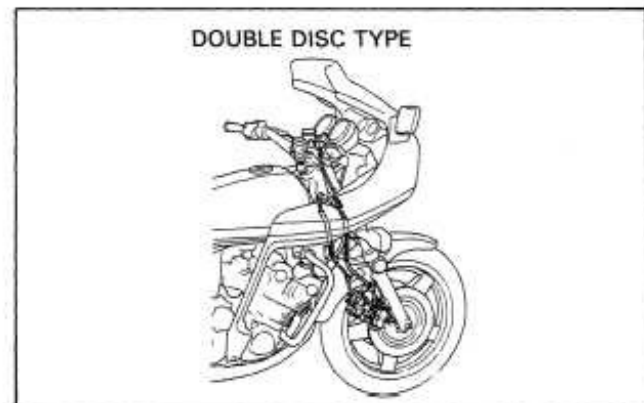
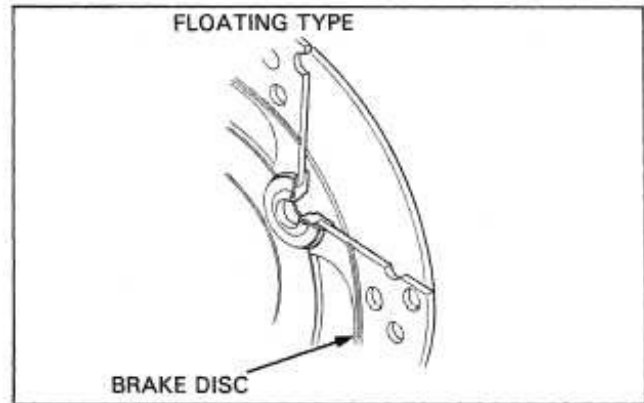

GENERAL INFORMATION FOR SERVICE

- Do not allow dust, dirt, water or any foreign material to enter the system when refilling or replacing the brake fluid.
- To maintain proper sealing and initial fit, replace the parts specified for replacement at the time of service. Replace the required parts as a set, when specified, for the same reason.
- Clean the sliding surfaces of the brake pads and disc with brake cleaner. Replace the pads if they are contaminated with oil or grease, as this significantly reduces braking force.
- The brake calipers can be removed from the motorcycle and the pads can be replaced without disconnecting the hydraulic system.

- Bleed the hydraulic system if it has been disassembled or if the brake feels spongy.
- If brake pads or shoes have been overheated (glazed), they must be replaced. Overheating changes the composition of the friction material and merely wire brushing or sanding the friction surface cannot change this fact.
- Always replace hydraulic line/hose sealing washers with new ones when reassembling. These sealing washers are made of aluminum alloy for effective sealing and are distorted once they are used.

Use caution when handling and installing brake lines and hoses. When installing front brake lines, be sure that there is no possibility of damage or stress to the lines or hoses when the fork pivots fully in either direction or when the suspension compresses or extends. In the rear, allow proper clearance so that the lines or hoses do not rub against the tire, frame or swingarm, and so they are not caught between the coils of the spring when the suspension compresses.

All brake lines or hoses should be installed using the clamps provided. Each clamp should be positioned around the rubber hose guards to prevent any damage to the lines and hoses.

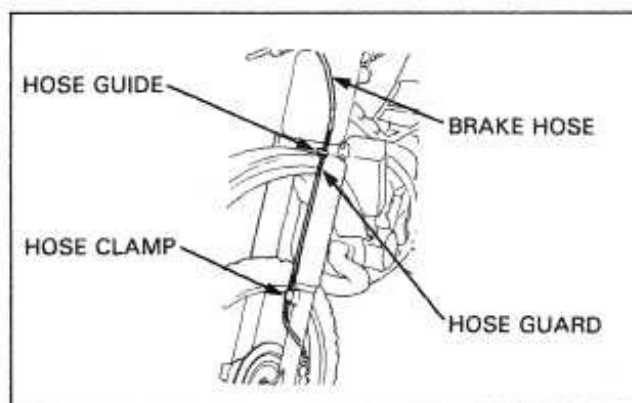

Eyelet-type line and hose joints:

Use new sealing washers whenever eyelet-type joints are reinstalled. Be sure the hose bolt fluid passage is free from clogging prior to installation.

Note the position of the stopper that aids in positioning the eyelet at the proper angle when installing the hose onto the master cylinder. If only one stopper is provided, press the hose end against the stopper while tightening the bolt. If two stoppers are provided, install the hose between the stoppers so that the hose will not move when the bolt is tightened.

If the sealing washer includes a stopper with collapsible claws, be sure to note the direction these claws face so the new washer can be installed in the same position.

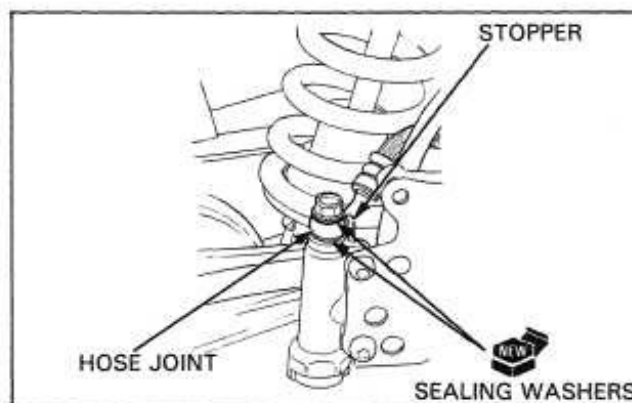

Hose Joints:

Removal

Remove the hose by loosening the joint nut while holding the hose nut stationary. This method prevents the hose from being twisted or kinked.

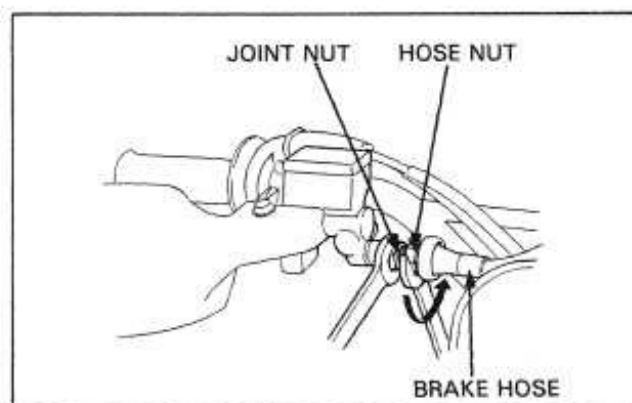

BRAKES

Installation

First install the hose joint onto the master cylinder with a new sealing washer and tighten it to the specified torque if it was removed.

Then, while holding the hose nut, tighten the joint nut to the specified torque.

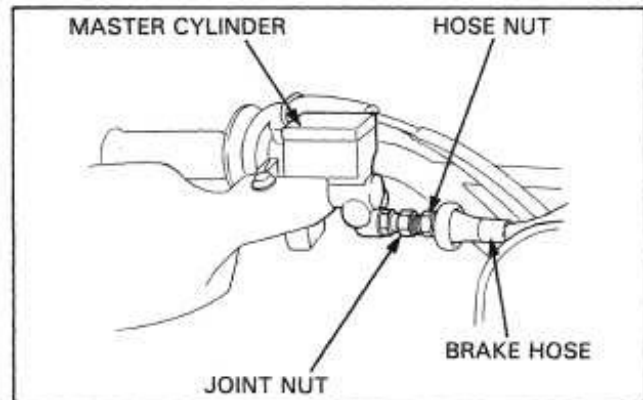

Metal Brake Lines:

Removal

If the metal brake line is equipped with nuts as illustrated, always loosen the flare nuts first, using a flare nut wrench, so that the hose may be easily maneuvered. Remove the metal line using care not to bend it.

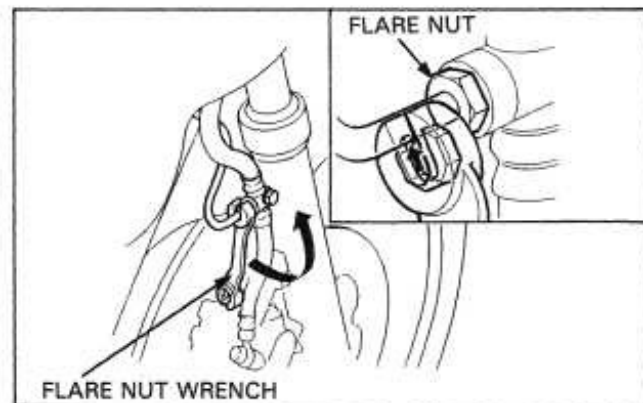

Installation

Always tighten brake line nuts first by hand. Then, confirm that the connections are free of play and tighten to the specified torque using a flare nut wrench.

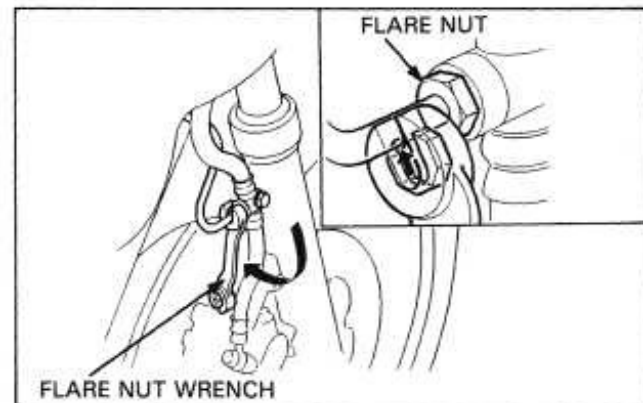

HYDRAULIC DISC BRAKES

BRAKE FLUID REPLACEMENT

Before removing the reservoir cover, turn the handlebar until the reservoir is level.

Place a rag over painted, plastic or rubber parts whenever the system is serviced.

CAUTION

- Spilling fluid on painted, plastic or rubber parts will damage them.

Remove the master cylinder cover and diaphragm.

Discard contaminated pads and clean a contaminated disc with a high quality brake degreasing agent.

WARNING

- A contaminated brake disc or pad reduces stopping ability.

Refill with the same type of fluid.

WARNING

- Mixing incompatible fluids will impair braking efficiency.
- Foreign materials can clog the system, causing a reduction or complete loss of braking ability.

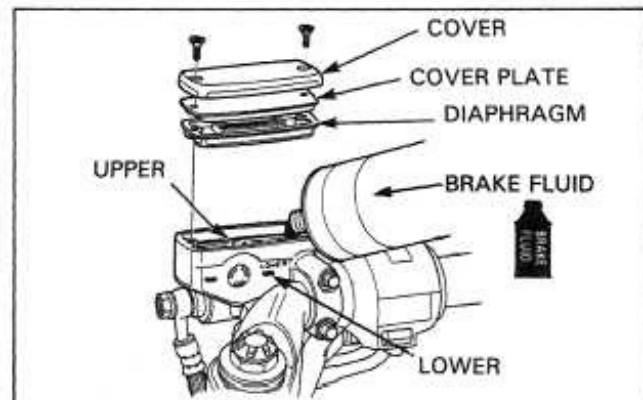

Connect a bleed hose to the bleed valve.

Loosen the caliper bleed valve and pump the brake lever or pedal. Stop operating the lever or pedal when fluid stops flowing out of the bleed valve.

Close the bleed valve and fill the master cylinder with the specified brake fluid. Refer to the Model Specific manual.

CAUTION

- Reusing drained fluids can impair braking efficiency.

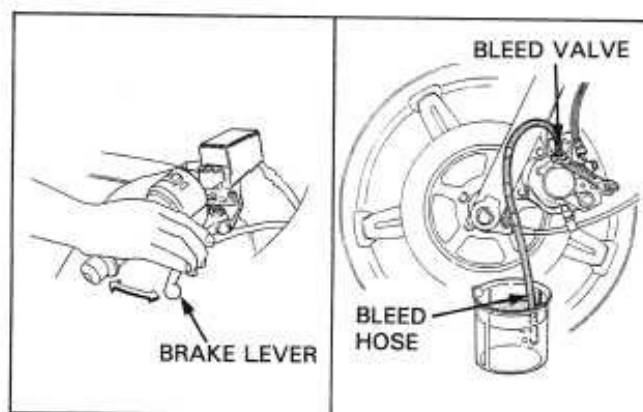

Connect a commercially available Brake Bleeder to the bleed valve.

NOTE

- When using a brake bleeder, follow the manufacturer's operating instructions.

Pump the brake bleeder and loosen the bleed valve.

Add fluid when the fluid level in the master cylinder is low.

Repeat the above procedures until there are no air bubbles in the plastic hose.

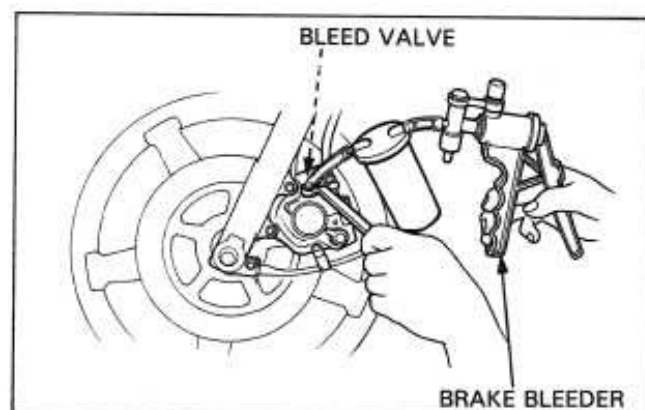

NOTE

- Check the fluid level often while bleeding the brakes to prevent air from being pumped into the system.
- Use only specified brake fluid from a sealed container.
- If air is entering the bleeder from around the bleed valve threads, seal the threads with teflon tape.

If the brake bleeder is not available, perform the following procedure:

Connect the the transparent bleeder hose to the bleed valve and place the other end of the hose in a container.

Loosen the bleed valve 1/4 turn and pump the brake lever or pedal until there are no air bubbles in the bleed hose and lever or pedal resistance is felt.

After filling the system, close the bleed valve and inspect the system for airbubbles by operating the brake lever or pedal. If it feels spongy, bleed the system as follows:

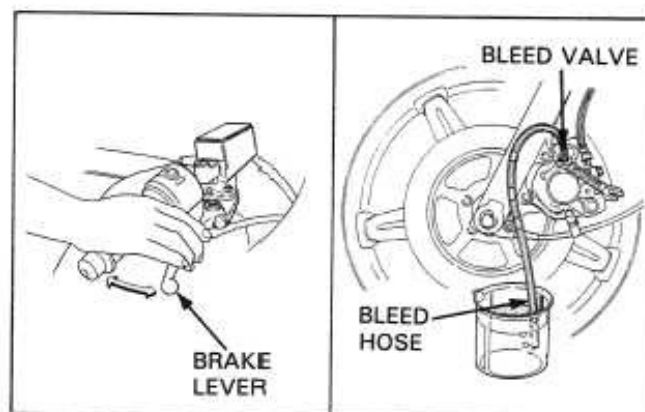

BRAKES

AIR BLEEDING

1. Squeeze the brake lever, then open the bleed valve 1/4 turn and close the valve.

NOTE

- Do not release the brake lever or pedal until the bleed valve has been closed.
- Check the brake fluid level often while bleeding the system to prevent air from being pumped into the system.

2. Release the brake lever slowly and wait several seconds after it reaches the end of its travel.
3. Repeat the steps 1 and 2 above until bubbles cease to appear in the fluid at the end of the hose.

Tighten the bleed valve.

Be sure that the brake fluid is up to the upper level of the master cylinder; refill if necessary.

Reinstall the master cylinder cover.

BRAKE PAD REPLACEMENT

Removal

There are two types of brake pads:

Type A: pad pin is secured by the retainer plate.

Type B: pad pin is secured by the pad pin plug.

Type A: Loosen the pad pin retainer bolt.

Type B: Remove the pad pin plug and loosen the pad pin.

Refer to the Model Specific manual for the caliper removal/installation.

NOTE

- Remove the pads without removing the bracket from the caliper. If the pads cannot be removed, remove the bracket.

Push the piston all the way in to allow the installation of new brake pads.

Type A: Remove the pad pin retainer bolt and the pad pin retainer.

Before removing the pads, mark them so you can reinstall them in their original positions if they are to be reused, thereby assuring even disc pressure.

WARNING

- Always reinstall the brake pads in their original positions to prevent loss of braking efficiency.

Type A: Pull out the pad pins and remove the pads.

Type B: Loosen the pad pins and remove the pins and pads.

NOTE

- Pad pins can be easily removed by pressing the pads in the caliper.

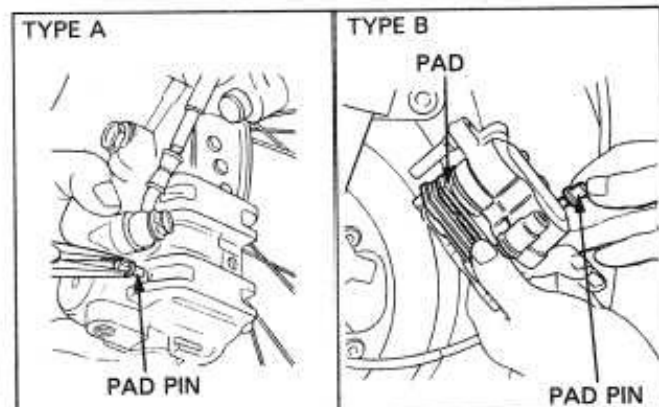
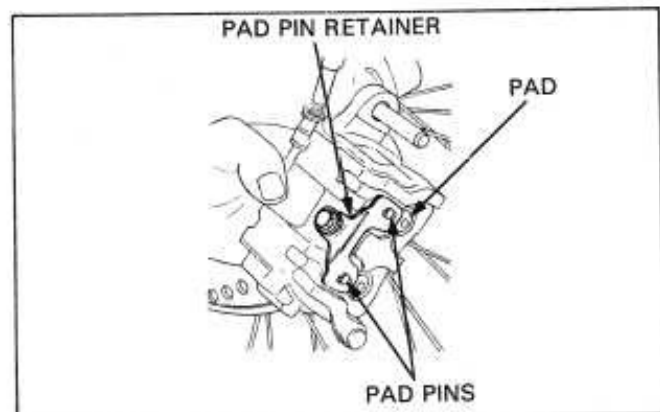
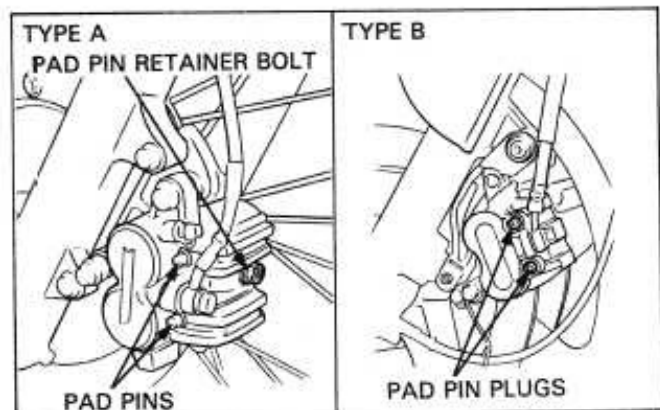
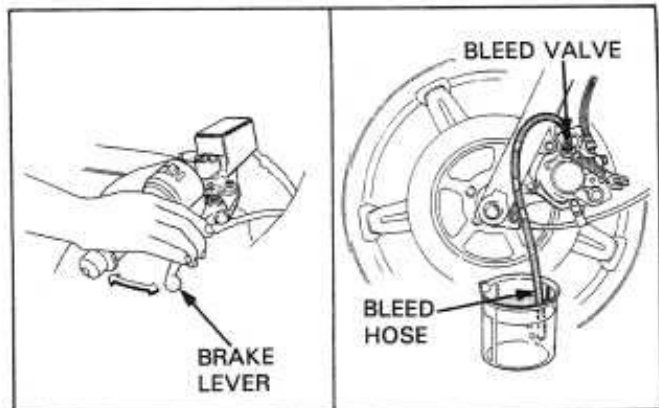

Installation

Press in the piston(s) to install the new pads.

NOTE

- Clean around the caliper pistons and the expose part of the pistons before press in the piston.

If the caliper and bracket are separate, apply silicone grease to the caliper pivot bolt boot, pin bolt, and collar bore and insert the caliper into the bracket.

Set the boot lip in the pin bolt groove securely.

Install the new pad, align the holes in the pad and retainer and install the pad pin. Note the installation direction of the pad.

NOTE

- Install the pad shim, if there is one, in the original position.

Type A: Install the retainer by aligning its hole with the pad pin groove and loosely tighten the bolt.

Install the caliper. (Refer to the Model Specific manual.)

Type A: Tighten the pad pin retainer bolt to the specified torque.

Type B: Tighten the pad pin to the specified torque and install the pad pin plug.

Apply the brake lever to force the caliper piston out of the caliper.

Rotate the wheel by hand and check the brake operation.

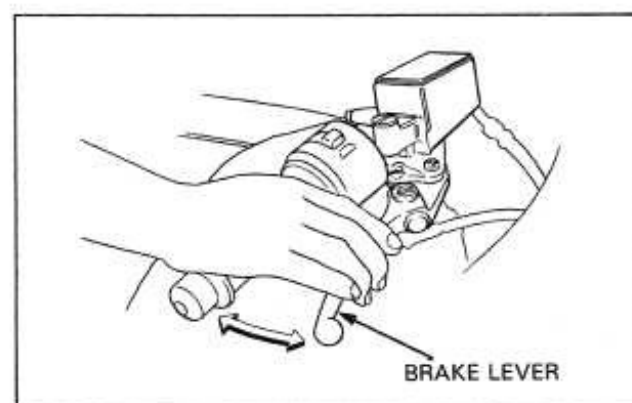
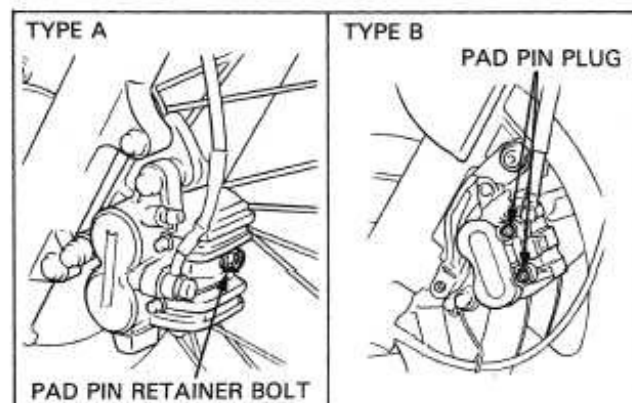
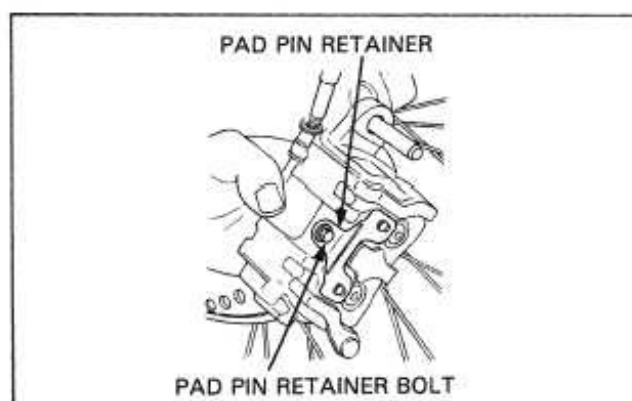
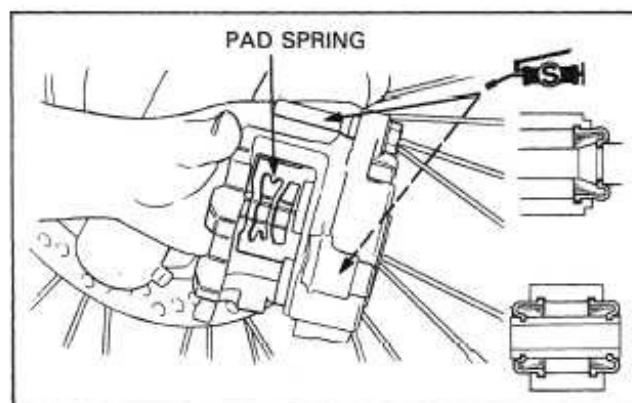

BRAKES

BRAKE CALIPER

Removal

Refer to the Model Specific manual for brake caliper removal/installation.

Pump the brake lever to force the caliper piston out of the caliper.

Place a clean container under the caliper and disconnect the brake hose from the caliper.

Avoid spilling brake fluid on painted surfaces.

CAUTION

- Spilled brake fluid will damage painted, plastic or rubber parts.

Remove the brake caliper assembly.
Remove the pads from the caliper.

Disassembly

Remove the following:

- caliper bracket
- pad spring
- pivot collar
- boot

Clean all of the removed parts except the brake pads with fresh brake fluid.

Remove the piston.

If necessary apply compressed air to the caliper fluid inlet to get the piston out. Place a shop rag under the caliper to cushion the piston when it is expelled. Use low pressure air in short spurts.

CAUTION

- Be careful not to damage the caliper cylinder bore when removing the seals.

Push the piston seal and dust seal in and remove them.

Clean the caliper, especially the brake piston seal grooves, with fresh brake fluid.

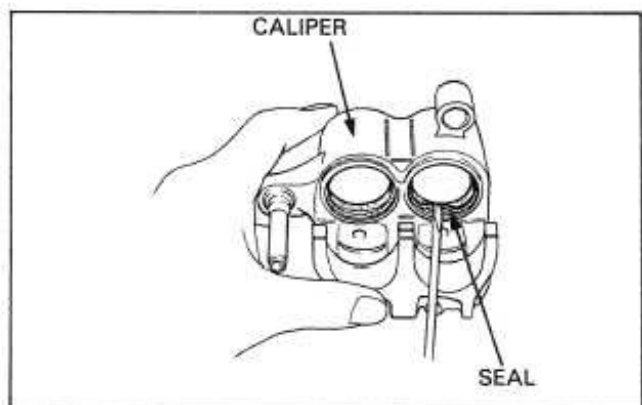
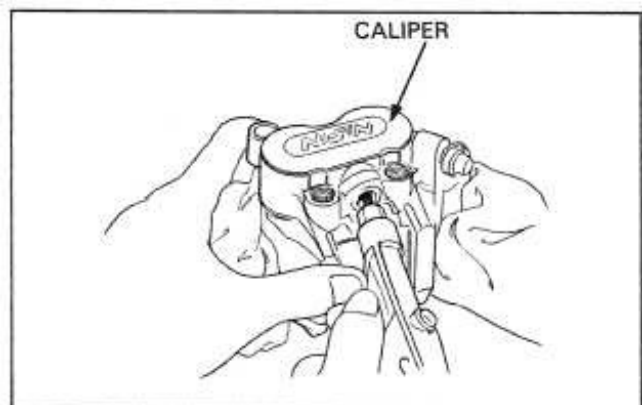
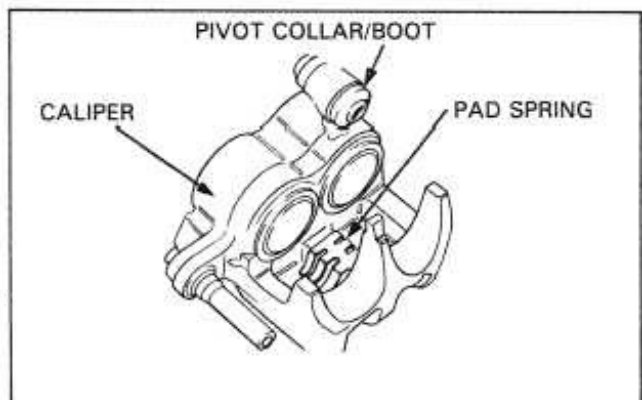
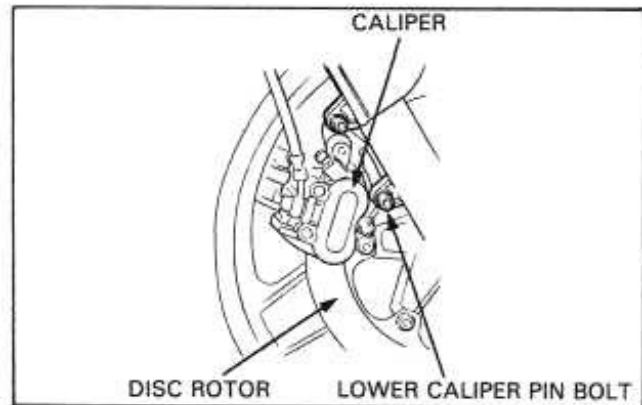

Caliper Cylinder Inspection

Check the caliper cylinder bore for scoring, scratches or other damage.

Measure the caliper cylinder I.D. in X and Y axis at several points.

Replace the caliper cylinder if the largest measurement is beyond the specified service limit.

Refer to the Model Specific manual for the service limit.

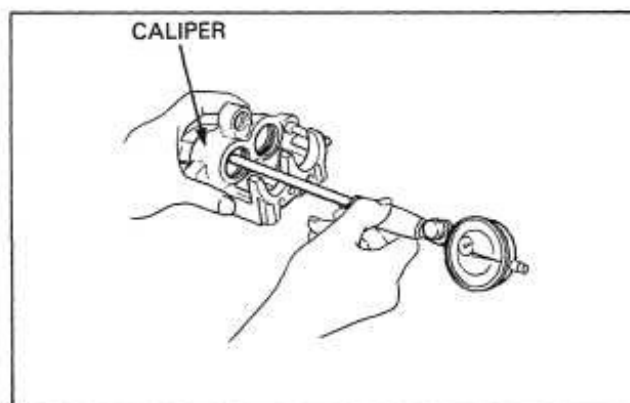
**Caliper Piston Inspection**

Measure the caliper piston O.D. in X and Y axis at several points.

Replace the caliper piston if the smallest measurement is less than the specified service limit.

Refer to the Model Specific manual for the service limit.

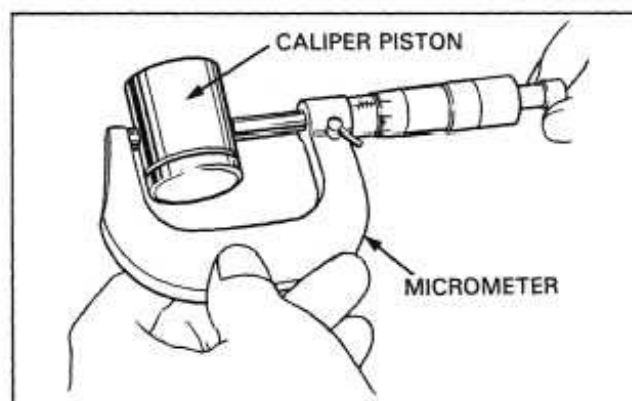
**Assembly****NOTE**

- Make sure that each part is free from dust or dirt before reassembly.
- Replace the dust seals and piston seals as a set whenever they are removed.

Coat the new piston seals with the recommended brake fluid and install them in the caliper cylinder grooves.

Coat the dust seals with silicon grease and install them in the caliper cylinder grooves.

Coat the caliper piston with fresh brake fluid and install it in the caliper.

There are two types of caliper pistons: resin pistons are mounted on light-weight motorcycles while metal pistons are used on heavy-weight motorcycles. The installation direction is different according to the type of the piston.

Resin piston: Install with the concaved side away from the pad.

Metal piston: Install with the opening toward the pad.

Install the pad spring in the caliper.

Refer to the Model specific manual for the installation direction of the spring.

Install the pad (page 17-10).

Install the caliper. (Refer to the Model Specific manual.)

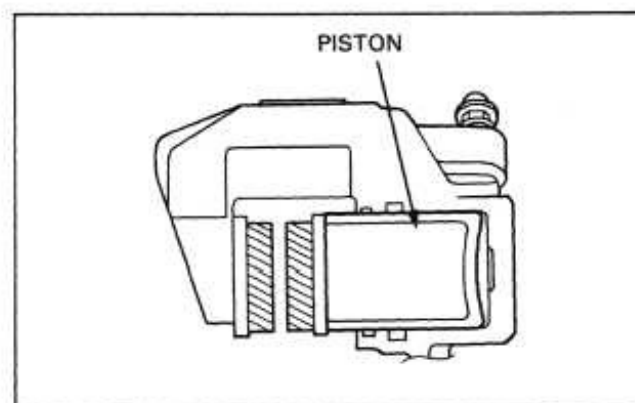
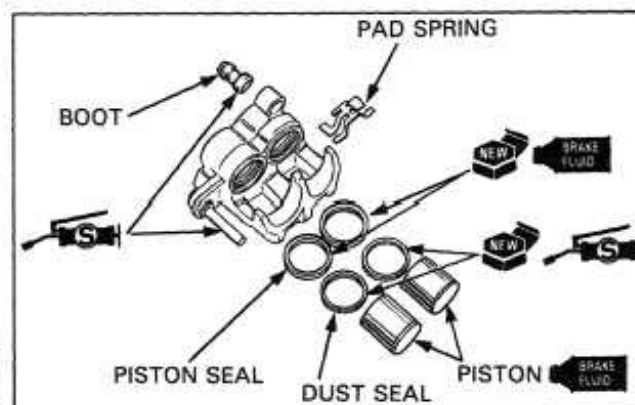

BRAKES

BRAKE DISC INSPECTION

Visually inspect the discs for damage or cracks.

Measure the brake disc thickness at several points and replace the disc if the smallest measurement is less than the specified service limit.

Refer to the Model Specific manual for the service limit.

NOTE

- The service limit is stamped on some discs.

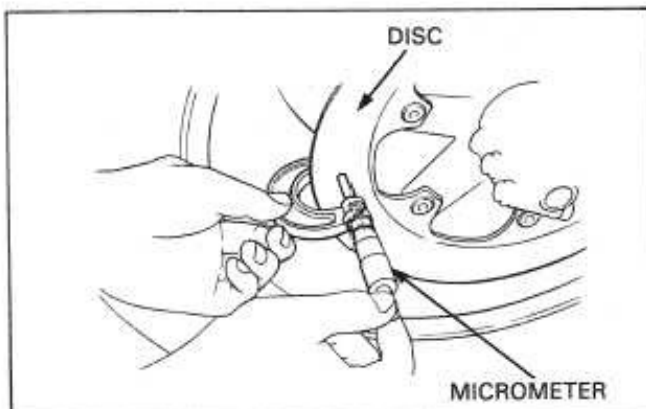

Check the brake disc for warpage.

Inspect the wheel bearings for excessive play if the warpage exceeds the specification. Replace the brake disc if the wheel bearings are normal.

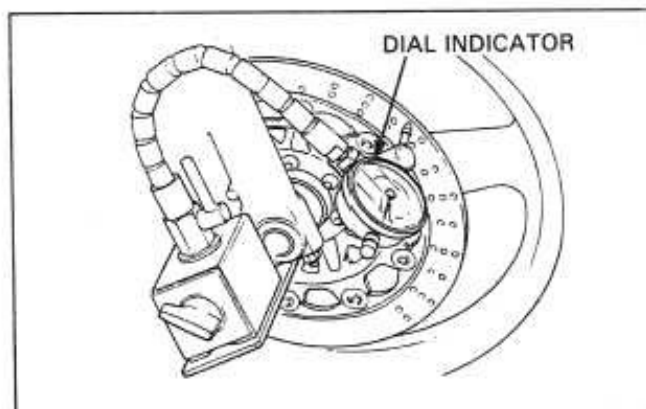

MASTER CYLINDER

Disassembly

CAUTION

- Do not allow foreign materials to enter the master cylinder.

NOTE

- Replace the master piston, spring, cups and snap ring as a set whenever they are disassembled.

Disconnect the wire from the brake light switch.
Drain the brake fluid (page 17-9).
Remove the brake lever from the master cylinder.
Disconnect the brake hose.
Remove the master cylinder holder and the master cylinder.

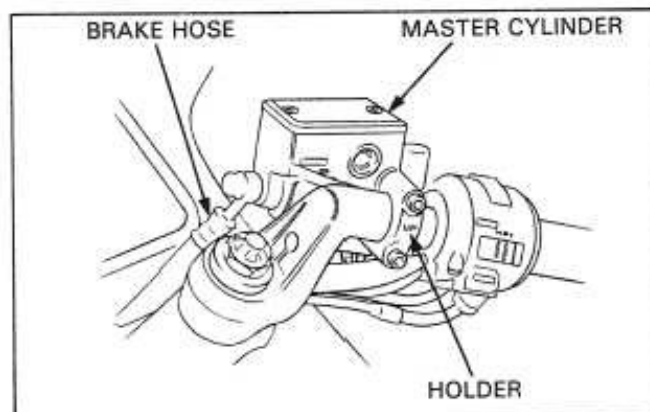

Remove the rubber boot.

Remove the snap ring.

 S TOOL

SNAP RING PLIERS

07914-3230001

Remove the piston and spring.

Clean the master cylinder with the recommended brake fluid.

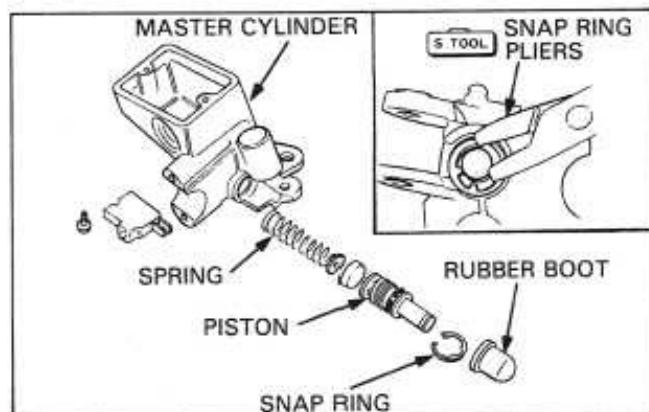

Master Cylinder Inspection

Check the master cylinder for scores, scratches or nicks and replace if necessary.

Measure the master cylinder I.D. in X and Y axis at several points.

Replace the master cylinder if the largest measurement is over the specified service limit.

Refer to the Model Specific manual for the service limit.

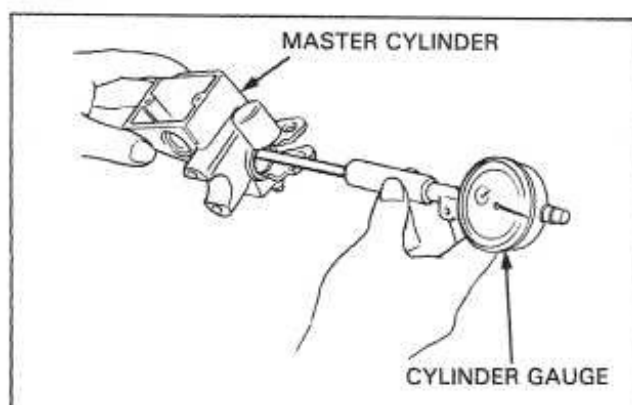

Master Cylinder Piston Inspection

Measure the piston O.D. at the several points on the secondary cup seat and replace it if the smallest measurement is less than the specified service limit.

Refer to the Model Specific manual for the service limit.

NOTE

- Replace the master cylinder if it leaks with a new piston installed.

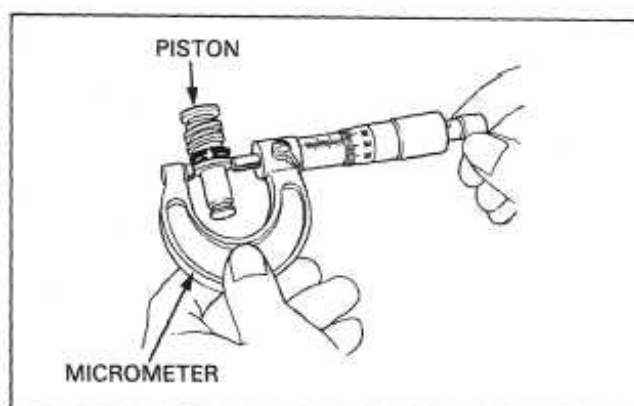

Assembly

NOTE

- Replace the piston, spring, cups and snap ring as a set.
- Be sure that each part is free from dust or dirt before reassembly.

Coat the piston cup with the fresh brake fluid and install it on the piston.

Install the spring with its larger diameter end toward the master cylinder.

Install the primary cup with its concaved side toward the master cylinder.

Install the snap ring.



SNAP RING PLIERS

07914-3230001

CAUTION

- When installing the cups, do not allow the lips to turn inside out. (Refer to the drawing.)
- Be certain that the snap ring is seated firmly in the groove.

Install the rubber boot in the groove properly.

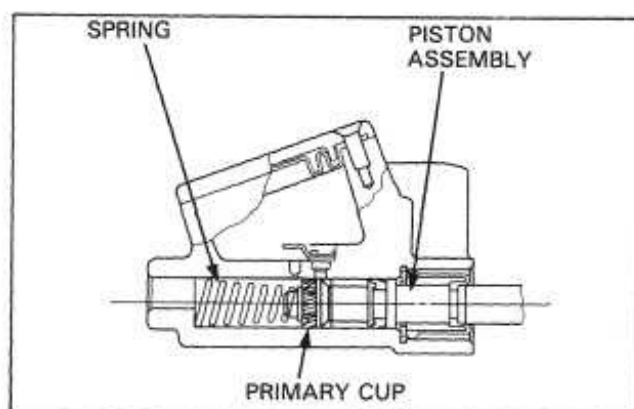
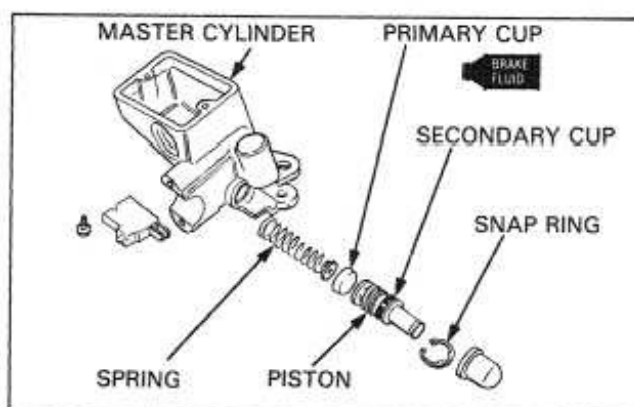

BRAKES

Place the master cylinder on the handlebar and install the holder and holder bolts with the holder's "UP" mark facing up.

Align the split between the holder and master cylinder with the punch mark on the handlebar.

Tighten the upper holder bolt to the specified torque first, then tighten the lower bolt to the same torque.

Install the brake lever and connect the wire to the brake light switch.

Connect the brake hose with two new sealing washers. Be careful not to twist the brake hose.

Tighten the brake hose bolt to the specified torque.

Make sure that the brake hose is routed properly.

Route all cables, hoses, and lines carefully to avoid kinking or pinching.

CAUTION

- Improper routing may damage cables, hoses, and lines.

▲ WARNING

- Kinked or pinched brake cables, hoses, or lines may cause a loss of braking ability.

Fill the system with specified grade of fluid and bleed the air from the system (Refer to page 17-10).

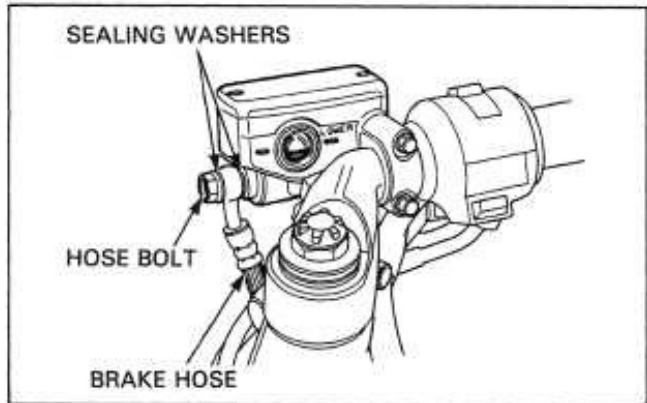
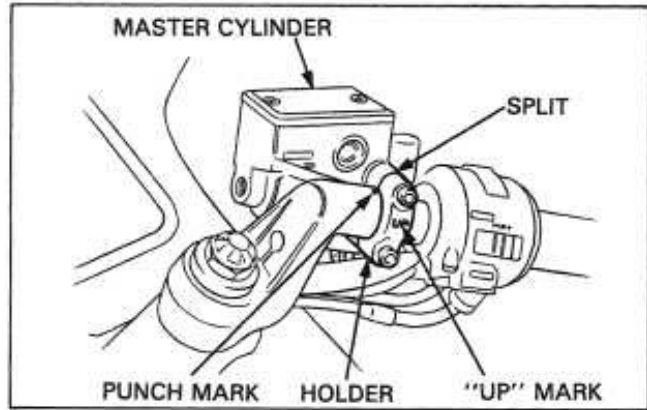

MECHANICAL DRUM BRAKES

▲ WARNING

- Inhaled asbestos fibers have been found to cause respiratory disease and cancer. Never use an air hose or dry brush to clean brake assemblies. Use an OSHA-approved vacuum cleaner or alternate method approved by OSHA, designed to minimize the hazard caused by airborne asbestos fibers.
- Grease on the brake linings will reduce stopping ability.

Remove the wheel.

Remove the brake panel from the wheel hub.

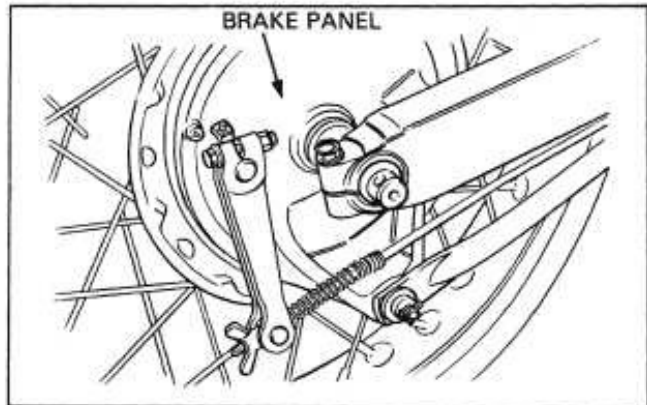

INSPECTION

Brake Drum I.D.

Check the brake drum for wear or damage. Replace the wheel hub if necessary.

Measure the brake drum I.D. (at the lining surface) at several points and take the largest measurement.

Refer to the Model Specific manual for the service limit or refer to the wheel hub if the service limit is stamped on it.

NOTE

- If the brake drum is rusted, clean with #120 emery paper.
- Be sure to use inside vernier calipers and measure the lining surface, not the drum's wear ridge.

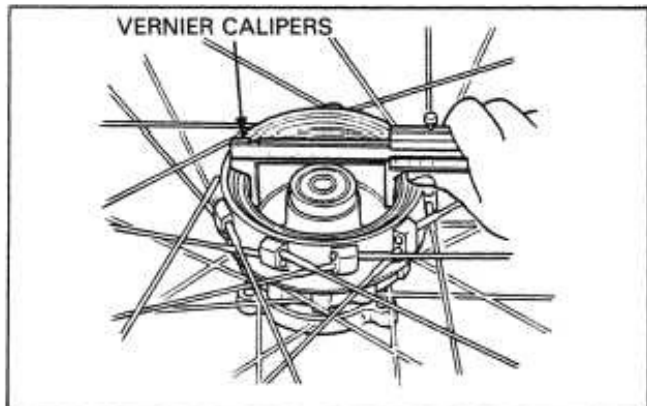

Brake Lining Thickness

Measure the brake lining thickness at 3 points (both ends and the center).

Replace the brake shoes in pairs if the smallest measurement is less than the service limit or if the lining are contaminated with grease.

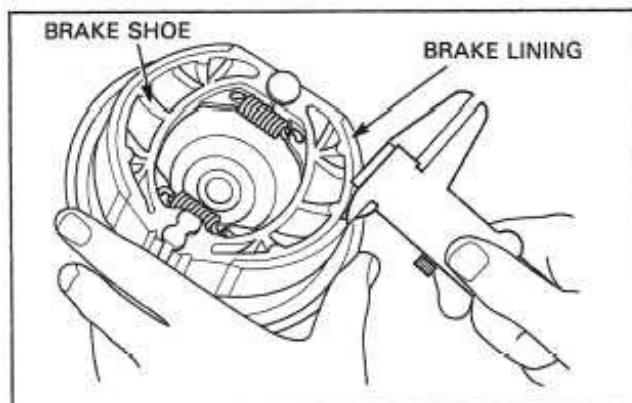
**DISASSEMBLY****NOTE**

- Replace the brake shoes in pairs.
- When the brake shoes are to be reused, mark the shoes' positions before disassembly so that they can be installed in their original positions.

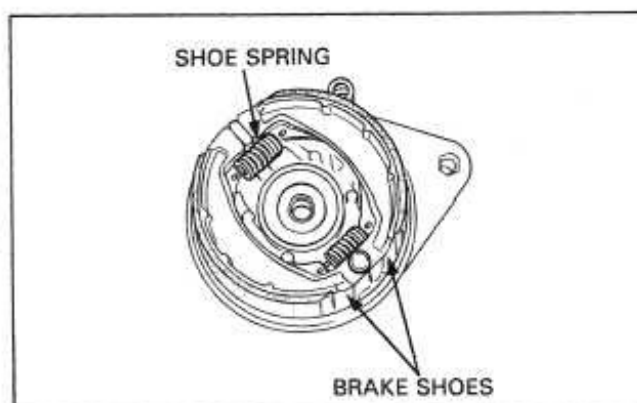
**U-Spring Type**

Move the brake arm and expand the brake shoes.

Remove the shoe spring from the anchor pin with a screwdriver.

Remove the brake shoes.

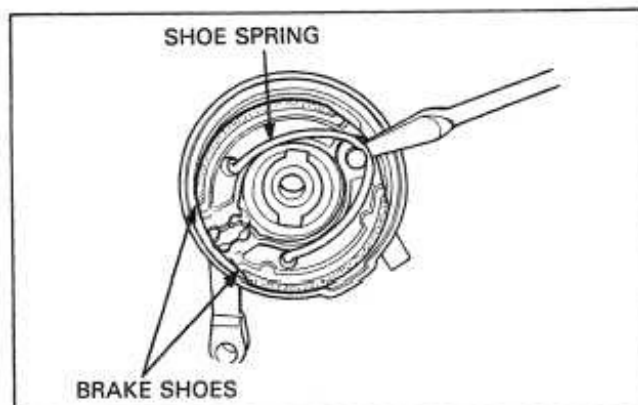
**Coil Spring Type**

Pull the brake shoes away from the anchors and remove the shoes.

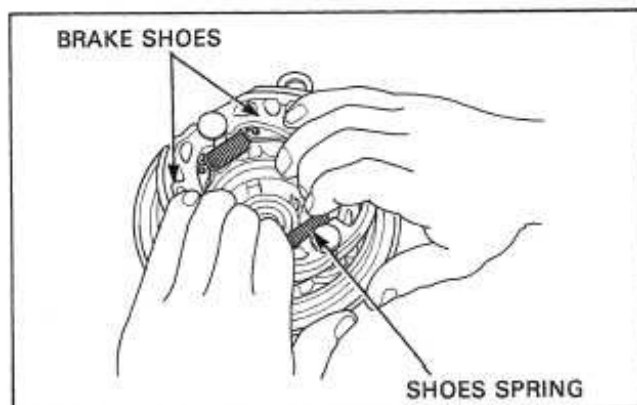

BRAKES

Remove the following from the brake panel.

- brake arm
- wear indicator plate
- felt seal/dust seal
- brake cam

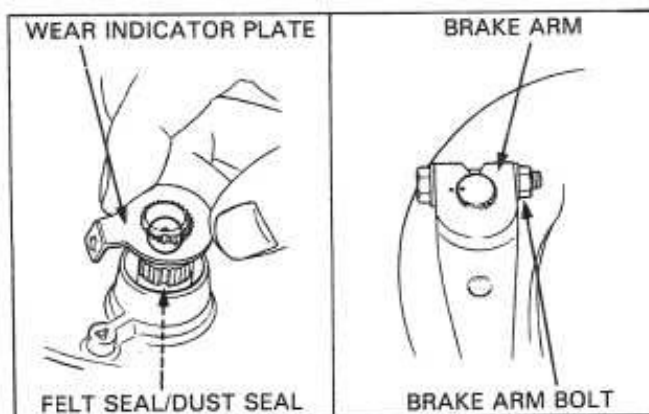

ASSEMBLY

Apply a small amount of grease to the brake cam and anchor pin.

Install the brake cam in the brake panel.

Keep grease off the brake linings.

Wipe excess grease off the cam and anchor pin.

▲ WARNING

- Grease on the brake linings will reduce stopping ability and may cause brake failure.

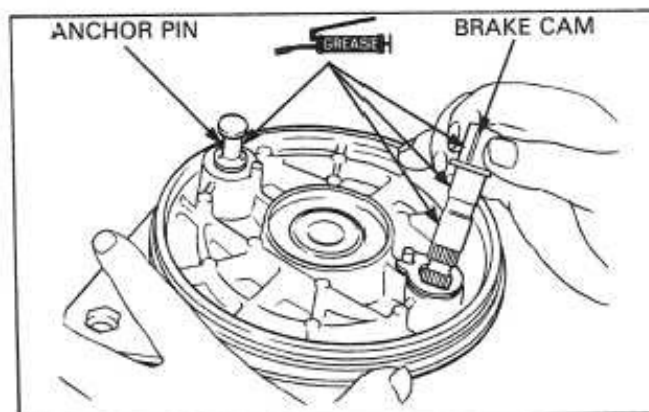

Felt seal: Apply a small amount of engine oil to the felt and install the felt seal on the brake panel.

Dust seal: Apply a small amount of grease to the dust seal lip and install.

Install the wear indicator plate by aligning its large serration with the large serration of the brake cam.

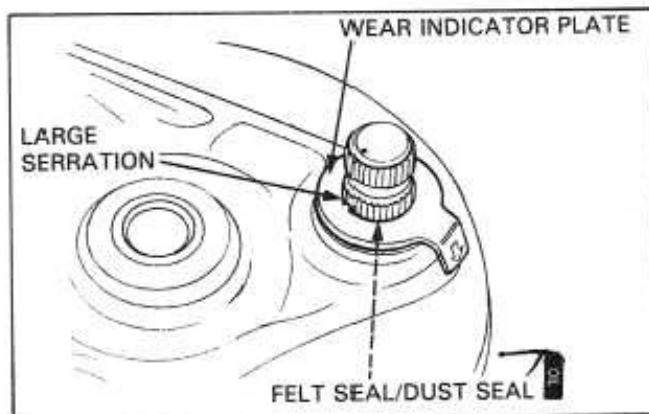

Install the brake arm on the brake cam while aligning the punch marks.

Tighten the arm bolt and nut to the specified torque.

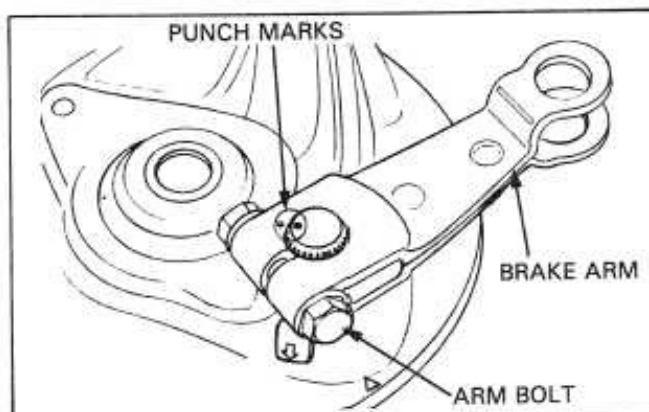

NOTE

- Install the brake shoes according to the position mark on each brake shoe.

Keep grease off the brake linings.

If the brake drum and linings are contaminated with grease, clean the brake drum with brake cleaner and replace both brake shoes.

▲ WARNING

- Grease on the brake linings will reduce stopping ability.

Coil spring type:

Install the shoe springs on the brake shoes.

NOTE

- Install the shoe springs with end side facing out.

Install a brake shoe on the brake panel, then install the other shoe being careful to keep the shoe springs in position.

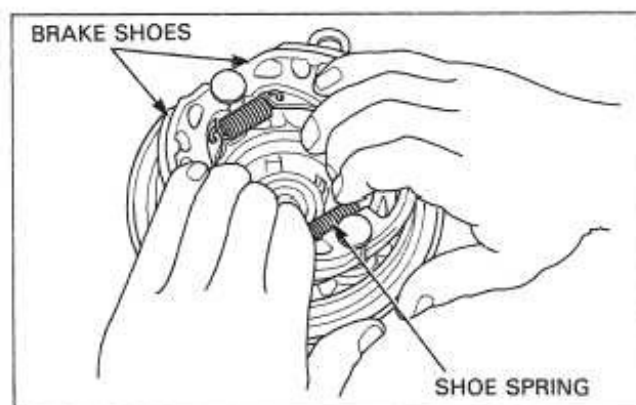
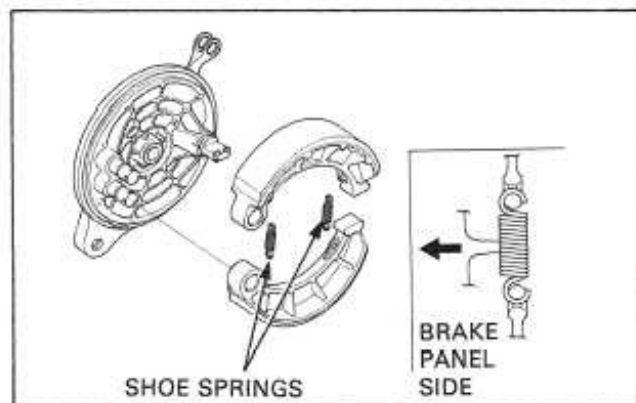
**U-spring type:**

Install the brake shoes on the brake panel and expand the shoes by moving the brake arm.

Install the shoe spring on the brake shoes and secure it on the anchor pin.

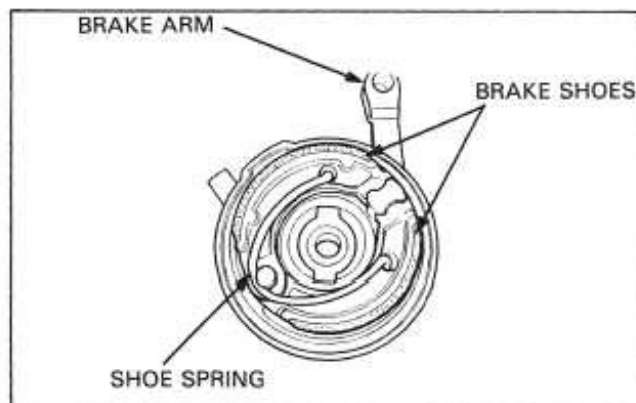

Install the brake panel on the wheel hub.

Install the wheel.

Front wheel: Check the Model Specific manual for the proper installation procedures.

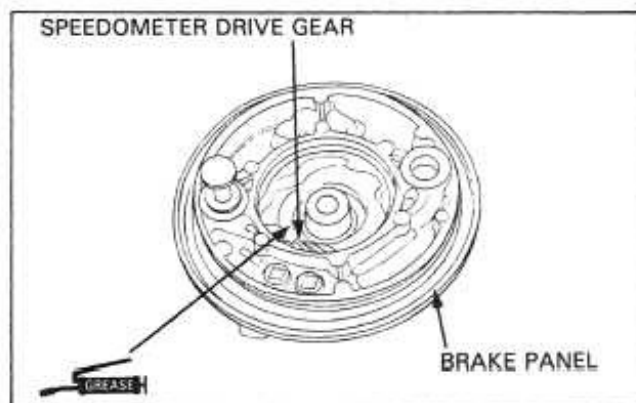

BRAKES

Rear wheel: Check the Model Specific manual for the proper installation procedures.

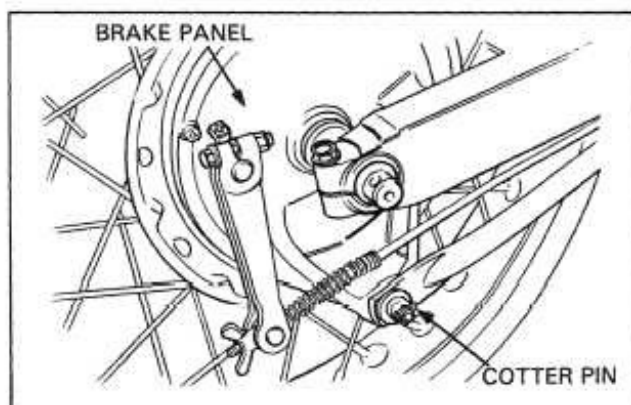

18. FRONT SUSPENSION

SERVICE INFORMATION	18-1	FORK	18-5
TROUBLESHOOTING	18-1	HANDLEBAR(S)	18-11
SYSTEM DESCRIPTIONS	18-2	STEERING STEM	18-15

SERVICE INFORMATION

▲ WARNING

- Riding on damaged rims or spokes impairs safe operation of the vehicle.

- When servicing the front wheel, support the motorcycle securely with a jack or other support under the engine.
- Refer to section 17 for brake system information.

TROUBLESHOOTING

Hard steering

- Steering adjustment nut too tight
- Faulty steering stem bearings
- Damaged steering stem bearings
- Insufficient tire pressure
- Faulty tire

Soft suspension

- Weak fork springs
- Telescopic type:
 - Insufficient fluid in fork
 - Low fluid level in fork
- Faulty anti-dive system

Steers to one side or does not track straight

- Unevenly adjusted right and left shock absorbers
- Bent fork
- Bent front axle: wheel installed incorrectly
- Faulty steering stem bearings
- Bent frame
- Worn wheel bearing
- Worn swingarm pivot components.

Hard suspension

- Bent fork components
- Bent damper rod (bottom link type)
- Telescopic type:
 - Incorrect fluid weight
 - Bent fork tubes
- Clogged fluid passage

Front wheel wobbling

- Bent rim
- Worn front wheel bearings
- Faulty tire

Front suspension noisy

- Worn slider or guide bushings (bottom link type)
- Insufficient fluid in fork
- Loose fork fasteners
- Lack of grease in speedometer gearbox

Wheel turns hard

- Brake misadjusted
- Faulty wheel bearing
- Faulty speedometer gear

FRONT SUSPENSION

SYSTEM DESCRIPTIONS

Telescopic and pivoting link-type front suspension systems are by far the most widely used types on motorcycles and scooters.

Telescopic front suspension systems are made up of a pair of upper fork tubes and lower fork sliders that telescope into one another. Within the set of tubes on either side is a spring and an oil damping system. Some systems utilize a cartridge damper within the fork sliders.

Basically, the oil controls the natural tendency of the spring to continue to rebound in ever decreasing amounts in both directions once acted upon by outside forces. Forcing the oil in each fork leg through a series of small holes, in effect, separates the rider/bike combination from both the unwanted characteristics of the spring and from height variations in the riding surface.

The pivoting link front suspension connects the axle to the fork by means of a pivoting link extending from the ends of the axle to the upper front portion of the fork. Between the pivot points on the fork and the axle are eyelets to which the spring/damper units are attached. The top of each 'shock absorber' is attached to the fork, up near the lower steering head bearing.

This design is divided into two basic categories. The trailing link design has the axle supported by links and 'shock absorbers' that 'trail' from the leading edge of the lower portion of the fork. The leading link type front suspension has the links pivoting toward the front and the 'shock absorbers' mounted to the leading edge of the fork.

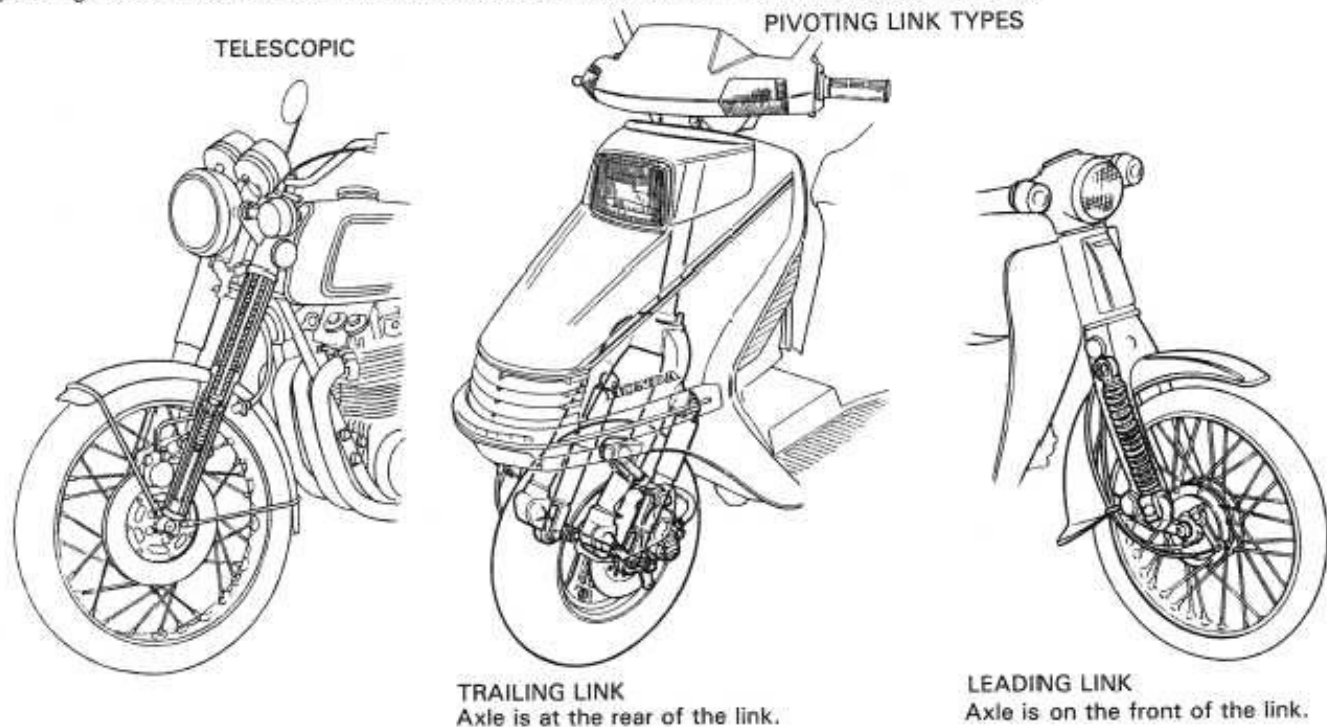

BASIC DAMPER OPERATION

Friction Damper Operating Principles

By far the simplest form of damper is the friction type. Instead of using oil to dampen the movement of the spring and suspension, the friction type uses only the friction of a single nonmetallic piston ring on the top of the damper rod pressing against the greased damper inner cylinder wall. This design is used primarily on only the smallest and simplest of vehicles.

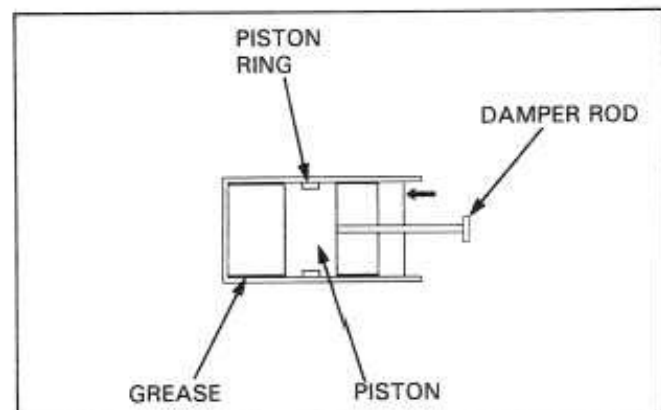

Oil Damper Operating Principles

The primary function of suspension dampers is to control the natural rebound energy of the suspension springs so that traction and ride comfort is maintained.

An oil damper controls the spring action by forcing oil to flow through a specific set of holes in the damper piston as the combined spring/damper compresses or extends. The resistance of the movement of the damper piston created by the oil within the damper controls the force of the spring. By varying the path the oil is forced to take on the compression and rebound strokes, the desired damping rates can be achieved.

On the compression stroke, oil is forced through several large capacity damping orifices so that the wheel can respond quickly to terrain changes. Since the wheel is free to move quickly, the average ride height of the machine is not disturbed.

On the rebound stroke, the force of the compressed springs is slowed by forcing the damper oil through fewer and or smaller damping holes. The proper damping characteristics allow the suspension to extend quickly enough to meet the next bump, but not so quickly that the motorcycle bounces from one bump to the next.

In the illustration to the right the compression stroke within a double wall damper is described. As the damper body is forced up against the spring and damper piston, oil is forced through the piston valve with little resistance. The primary resistance to this compression is the damper spring. The oil that passes through the piston merely flows to the upper side of the piston. At the same time, some oil is also allowed to flow out of the bottom valve. The quantity of oil that flows out of the cylinder bottom valve is equivalent to the amount drawn into the top. The combined resistance to flow through each of these valves is the compression damping.

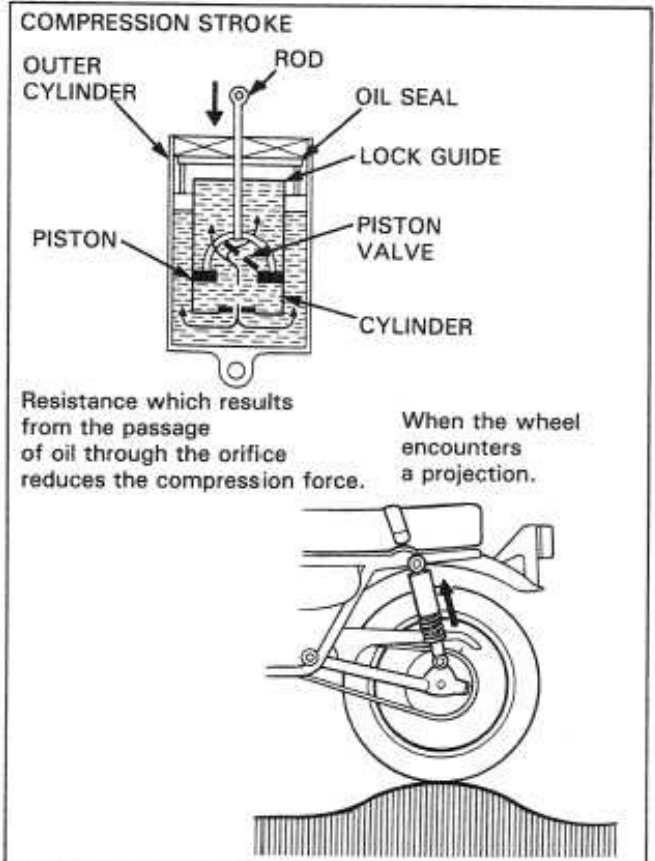
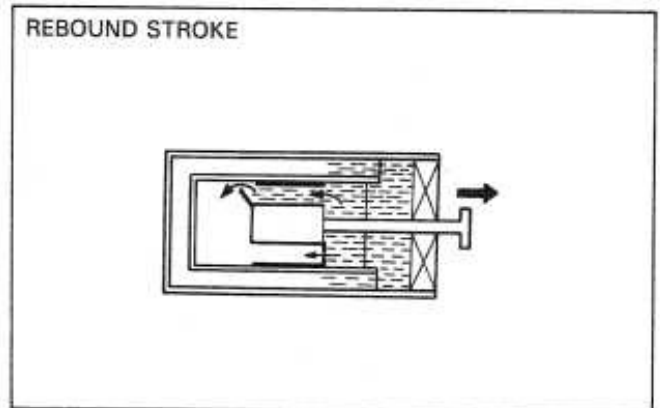
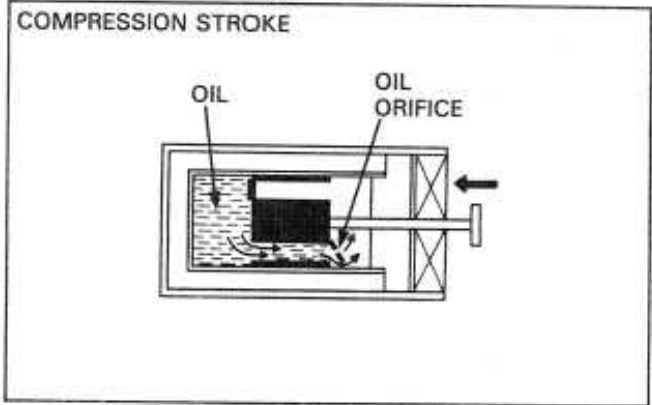

FRONT SUSPENSION

The rebound stroke is illustrated in this drawing. Once the wheel has overcome the bump, the spring forces the damper rod to force the piston back through the damper. Here, oil flows with little resistance into the cylinder, but there is considerable resistance caused by the damping valve in the piston.

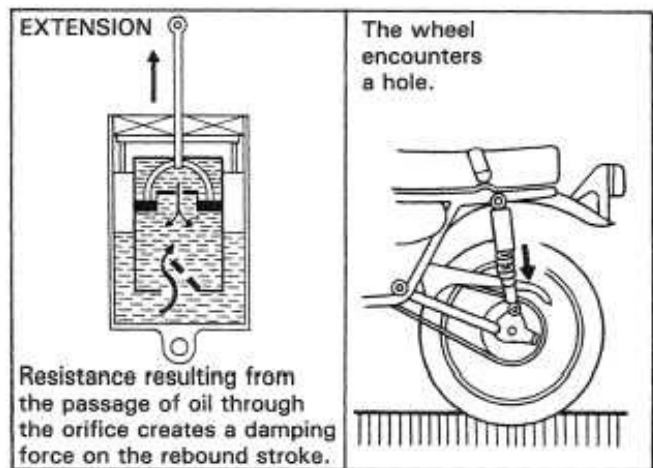

Telescopic Fork:

The telescopic fork serves as a skeletal member of the vehicle framework, a means for turning the vehicle and as the front suspension.

When the fork sliders move telescopically on the compression stroke, oil in Chamber B flows through the orifice in the fork tube into Chamber C, while the oil in Chamber B pushes past the free valve and up into Chamber A. The resistance in this oil flow absorbs shock on compression.

As the fork nears full compression, the tapered oil lock piece comes into play to hydraulically prevent the fork from bottoming.

On the rebound stroke, oil in Chamber A flows through the orifice in the top of the fork piston into Chamber C. Here the resulting resistance serves as a damping force and the tendency of the spring to rebound quickly is controlled.

The rebound spring absorbs the shock of the fork legs extending outward. Oil in Chamber C flows through the orifice in the bottom of the fork piston into Chamber B at this time.

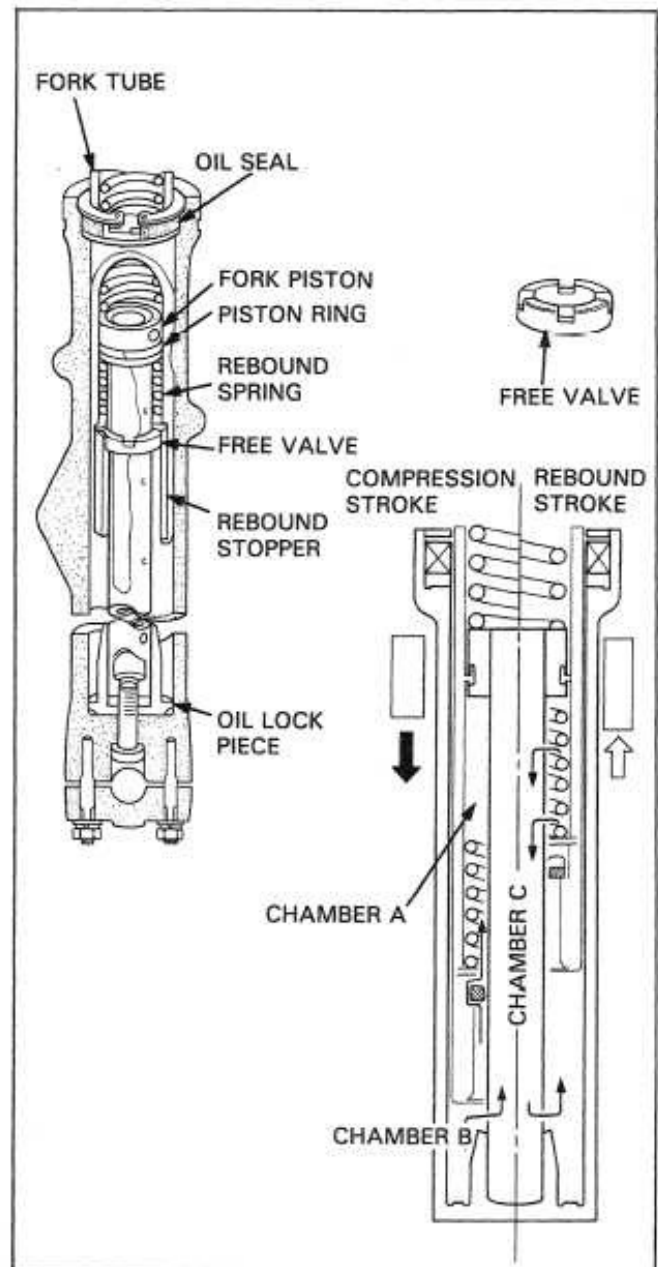

FORK

REMOVAL

Remove the following:

- Handlebar(s).
- Front wheel.
- Front fender.
- Front brake caliper(s) and bracket(s).
- Fork brace.

Loosen the fork pinch bolts.

Pull each fork leg out of the fork bridges by twisting while pulling them down.

Press the air valve core to release air pressure from the fork.

NOTE

If the fork legs are to be disassembled:

- Break the socket bolts in the bottom of the fork sliders loose, but do not unscrew them (oil will leak out).

To loosen the fork cap bolts:

- Because the clamping action of the pinch bolt(s) can distort the fork tubes slightly and prevent the caps from loosening, it is sometimes better to reposition the legs in the clamps so that the caps are 2 to 3 inches above the clamps, as shown in the first illustration on this page, prior to loosening them.

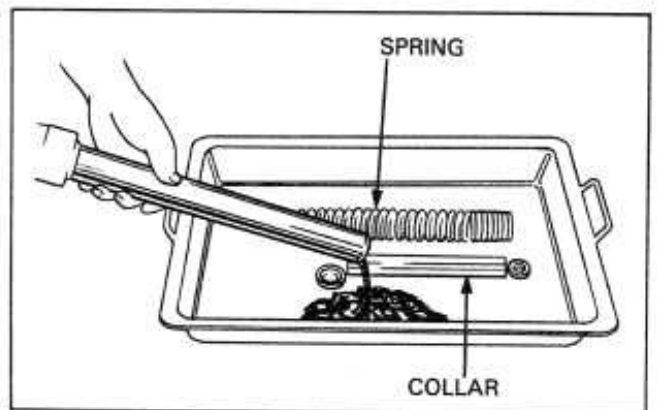
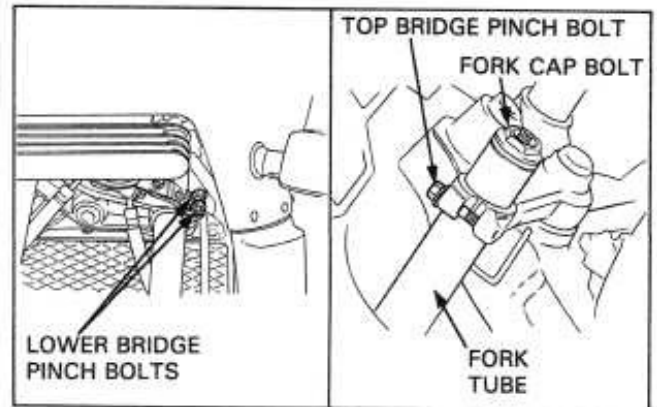

DISASSEMBLY

Remove the following:

- Fork boot (if used on the particular model)
- Fork cap bolt. (see note above)
- Spring seat.
- Collar.
- Fork spring.

Drain the fork oil by pumping the fork up and down several times.

Hold the fork slider in a soft jaw vise or use a shop towel.

Remove the socket bolt with a hex wrench.

NOTE

- Temporarily install the fork spring and fork cap bolt to loosen the socket bolt.

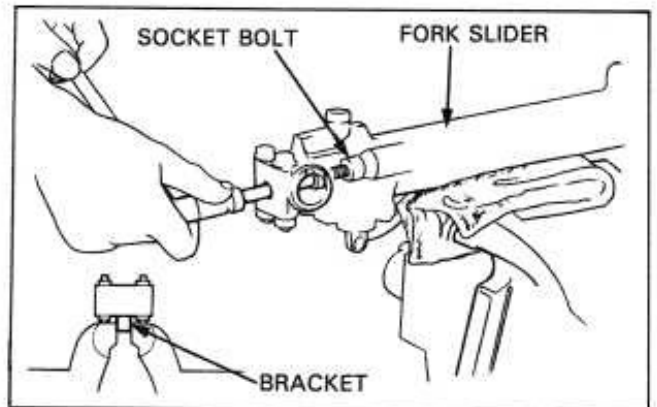

Remove dust seal, washer, and snap ring.

5 TOOL

SNAP RING PLIERS

07914-3230001

NOTE

- For models with a stop ring. Use a small blade screwdriver to carefully remove the stop ring from the groove (see page 18-9).

CAUTION

- Be careful not to damage the fork slider or the fork tube when removing the stop ring with the screwdriver.

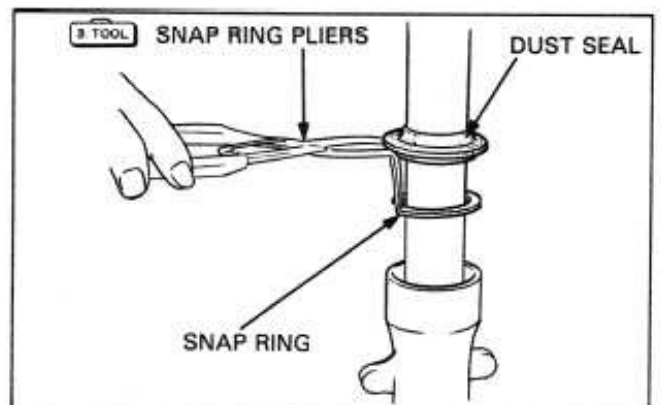

FRONT SUSPENSION

Pull the fork tube out of the fork slider.

NOTE

- If the type of fork being disassembled has a guide bushing installed, remove the fork tube as follows:

Pull the fork tube out until resistance from the slider bushing is felt. Then move it in and out, tapping the bushing lightly until the fork tube separates from the slider. The slider bushing will be forced out by the fork tube bushing.

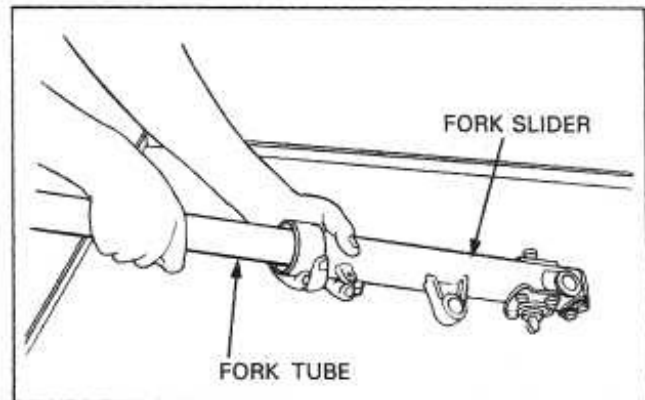

Remove the following:

- Oil seal.
- Back-up ring.
- Fork tube bushing.
- Guide bushing, if installed.
- Rebound spring, if possible.

NOTE

- Do not remove the fork tube bushings unless it is necessary to replace them with new ones.

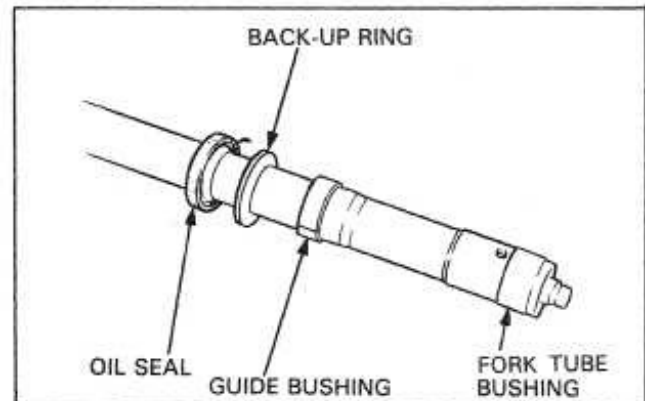

NOTE

- On the fork type that has no guide bushing, the oil seal may remain in the slider after the fork tube is removed. Remove the oil seal being careful not to damage the oil seal seating surface of the slider.

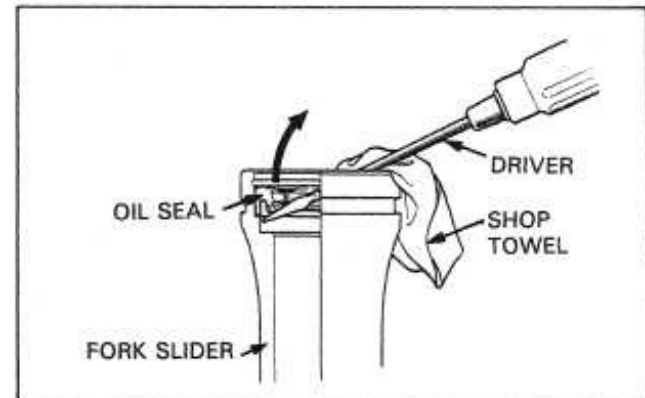

Remove the following:

- Oil lock piece from the fork slider.
- Stop ring from the fork piston.

Clean all disassembled parts.

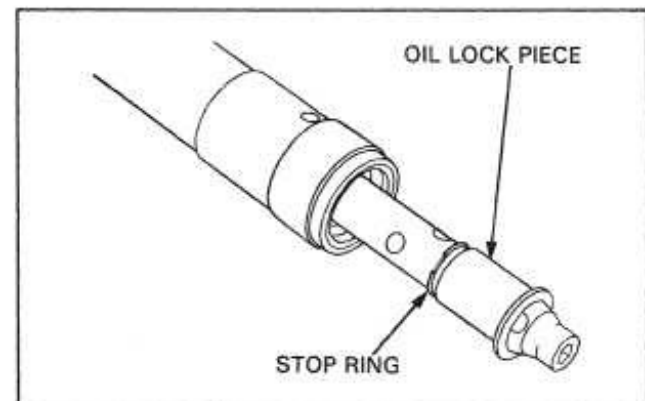

INSPECTION

Measure the fork spring free length by placing the spring on a flat surface. Replace the spring if it is shorter than the service limit.

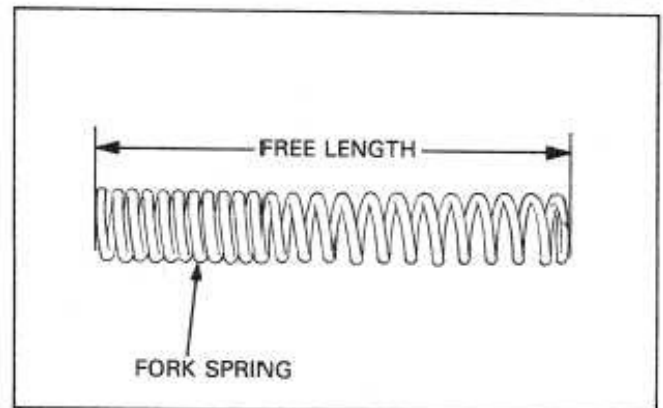

Set the fork tube in V-blocks and measure the fork tube runout by rotating it with a dial indicator mounted against it.

The actual runout is 1/2 of the total indicator reading. Replace if the service limit is exceeded, or there are scratches or nicks that will allow fork oil to leak past the seals.

NOTE

- Do not reuse the fork tube if it cannot be perfectly straightened with minimal effort.

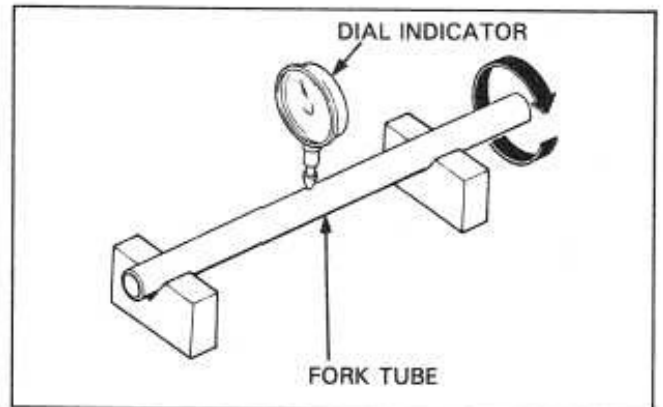

Visually inspect the slider and fork tube bushings. Replace the bushings if there is excessive scoring or scratching, or if the teflon is worn so that the copper surface appears on more than 3/4 of the entire surface.

Check the back-up ring: replace it if there is any distortion at the points shown.

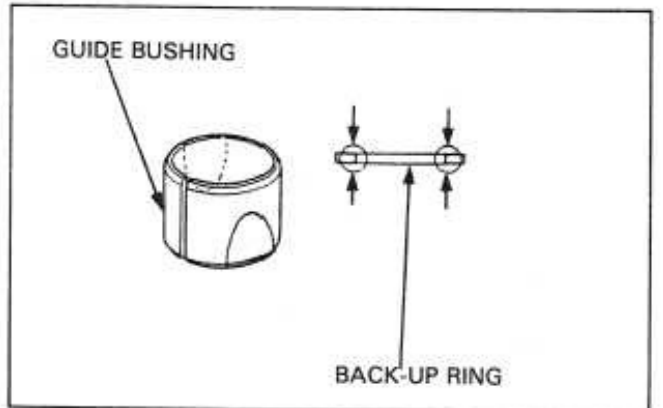

Check the fork sliders for internal scratches, dents that are visible from both the inside and outside, or abnormal wear. Replace the slider if necessary.

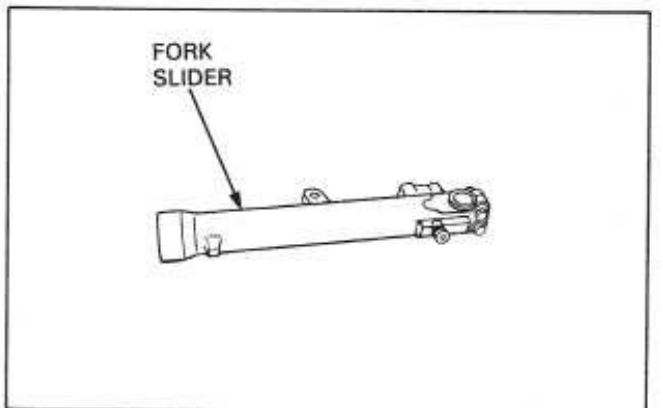

FRONT SUSPENSION

Check the fork piston and other components for damage, cracks, straightness or abnormal wear. Replace parts as necessary.

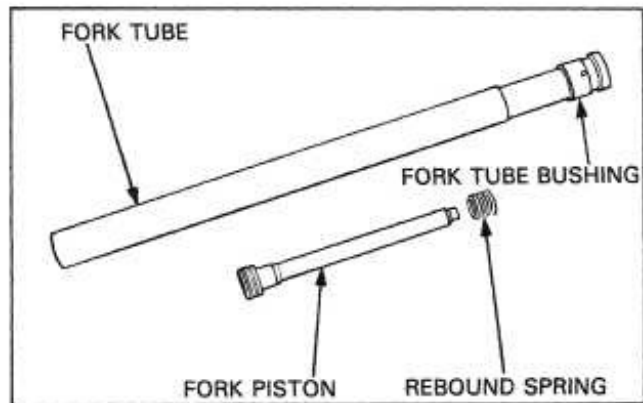

ASSEMBLY

Insert the fork piston into the fork tube

Install the following:

- stop ring onto the fork piston
- rebound spring onto the fork piston (if the rebound spring has been removed)
- oil lock piece

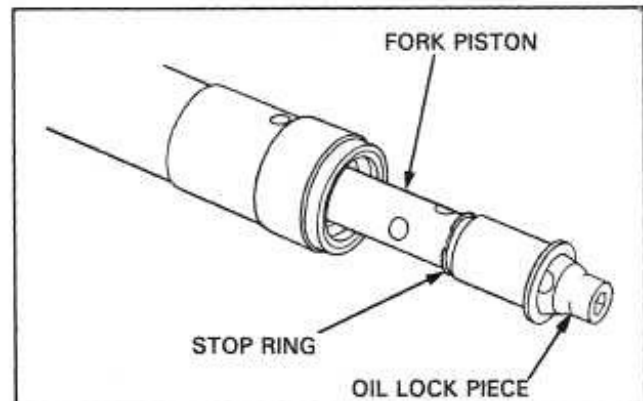

Replace the dust seal with a new one whenever it is removed.

Insert the fork tube into the fork slider.

Install the back-up ring and a new oil seal.

NOTE

- Inspect the fork tube sliding surfaces for damage whenever the oil seal is replaced due to oil leaks.
- Wrap vinyl tape around the fork tube top end to avoid damaging the oil seal during the oil seal installation.
- Apply fork oil to the oil seal lip.
- Install the oil seal with the marked side facing up.

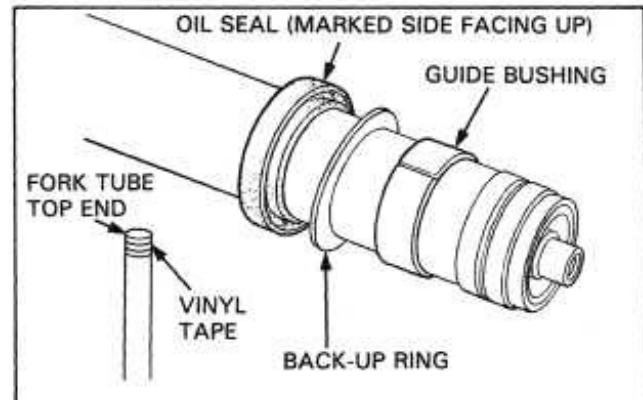

Install the guide bushing if it has been removed.

Place the fork slider in a vise, with soft jaws or a shop towel, clamping it at the brake bracket or caliper bracket as shown. Be careful not to distort the slider by clamping it in a vise incorrectly.

Apply a locking agent to the socket bolt and thread it into the piston. Tighten the bolt with a 6 mm hex wrench.

NOTE

- Temporarily install the fork spring and fork cap bolt so that the piston is held in place when the socket bolt is tightened.

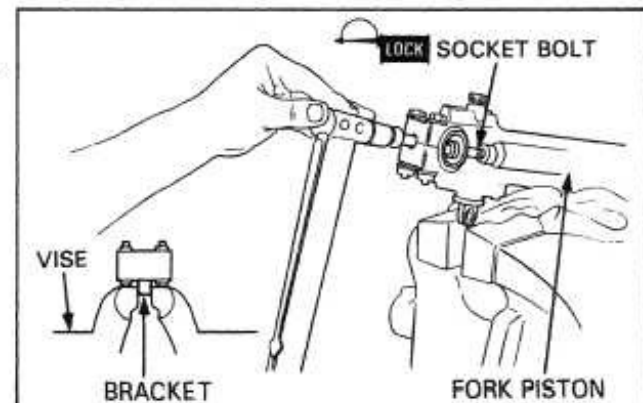

Place the slider bushing over the fork tube and rest it on the slider. Put the back-up ring and an old bushing or equivalent tool on top.

Drive the bushing into place with the seal driver and remove the old bushing or equivalent tool.

Coat a new oil seal with ATF and install it with the seal markings facing up. Drive the seal in with the seal driver.

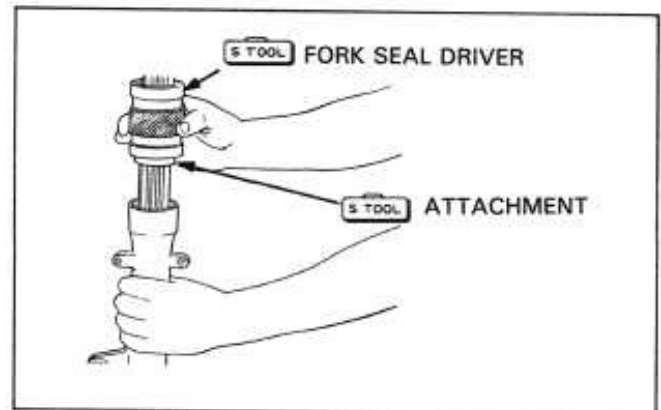

Install the snap ring with its radiused edge facing down.

Seat the snap ring firmly in the groove.

WARNING

- Failure to firmly seat the snap ring may cause the fork assembly to come apart unexpectedly and lead to a serious injury.

S TOOL

SNAP RING PLIERS

07914-3230001

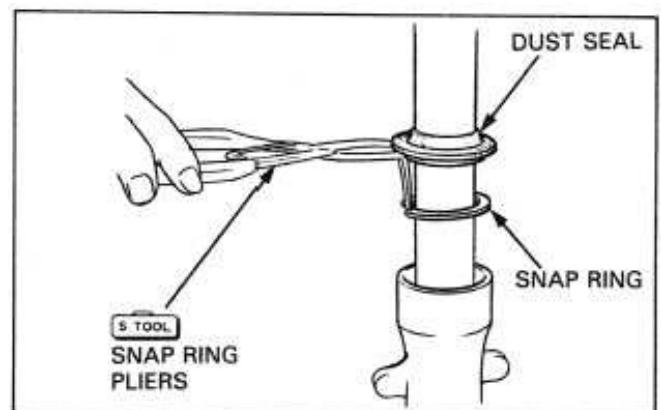

NOTE

- For models with a stop ring: Use a small flat-blade screwdriver to install the stop ring into the groove. Be careful not to damage the fork tube.

Install the dust seal using the fork seal driver.

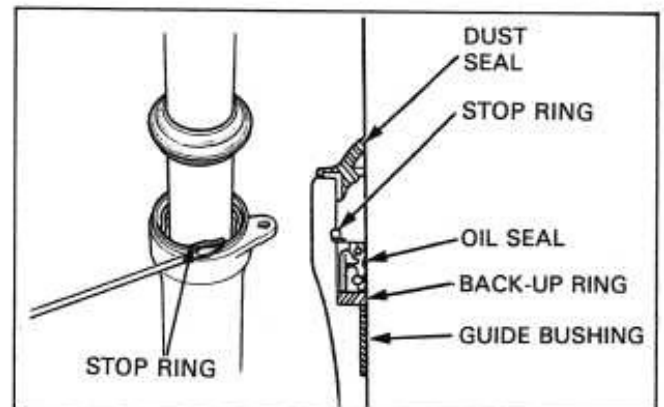

Pour the specified amount of fork oil into the fork tube.

Pump the fork tube several times to remove trapped air from the lower portion of the tube.

Compress the fork leg fully and measure the oil level from the top of the tube.

Wipe the oil off of the spring thoroughly using a clean, lint free shop towel.

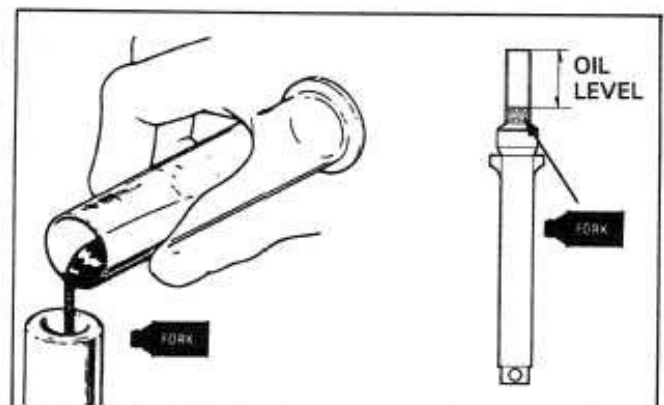

FRONT SUSPENSION

Pull the fork tube up and insert the spring.

NOTE

- Most fork springs are designed to be installed with a specific end toward the top and bottom.
- One end tapered: Install the spring with the tapered end down.
- Both ends tapered: If the distance between each of the coils is the same (straight wound spring), either end may be installed down. If the coils are closer together at one end (progressive wound spring), the widely spaced coils should be at the bottom.

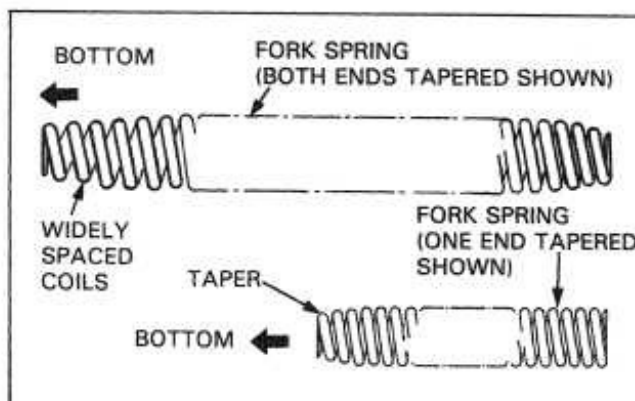

Reassemble the removed parts (spring, collar, etc.).

Install a new O-ring into the fork cap groove.

Screw the fork cap into the fork tube.

NOTE

- Tighten the fork cap to the specified torque after installing the fork tubes into the bridges and tightening the upper pinch bolts.

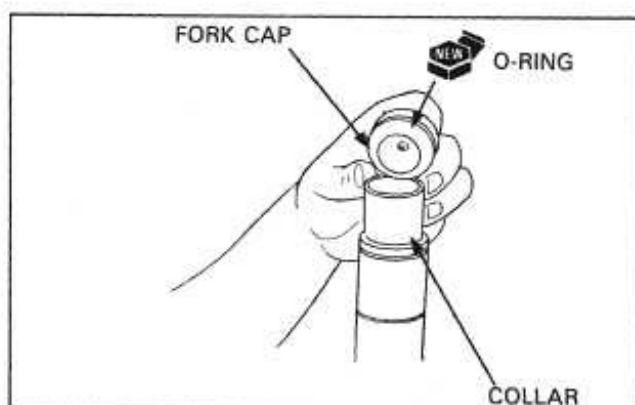

INSTALLATION

Install the fork boot (if the particular model uses one).

Install the fork legs through the fork bridges by twisting while pushing them upward.

Position the legs in the clamps as specified in the Model Specific manual.

NOTE

- Make sure that the cables and wire harnesses are routed correctly.

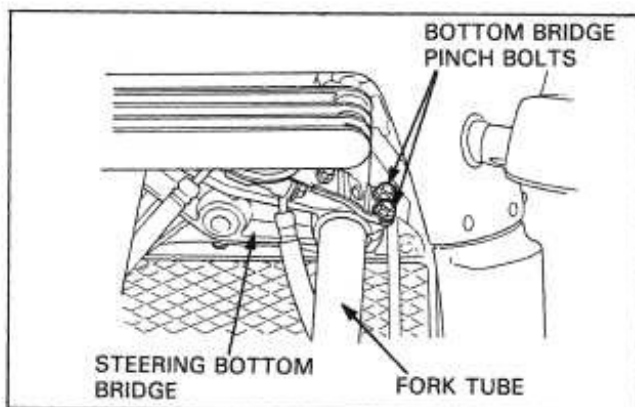

Tighten the fork bridge pinch bolts to the specified torque.

Tighten the fork caps to the specified torque.

Install the removed parts in the reverse order of removal (refer to the Model Specific manual).

With the front brake applied, compress the fork up and down several times to check for proper fork operation.

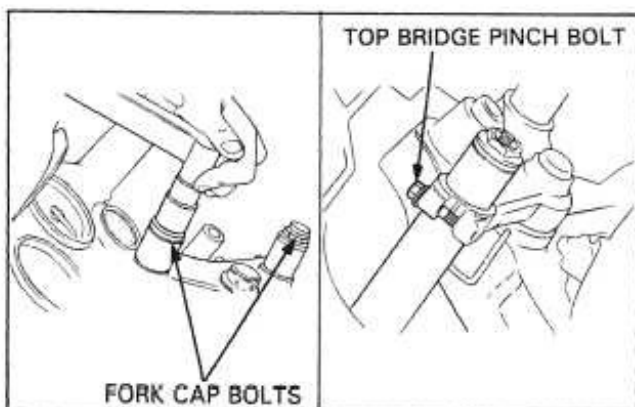

HANDLEBAR(S)**ONE-PIECE, TUBULAR TYPE****Removal**

Remove the following:

- Rear view mirror(s).
- Handlebar switches.
- Throttle cable.
- Brake and clutch lever brackets.
- Holder bolts.
- Handlebar upper holders.
- Handlebar.

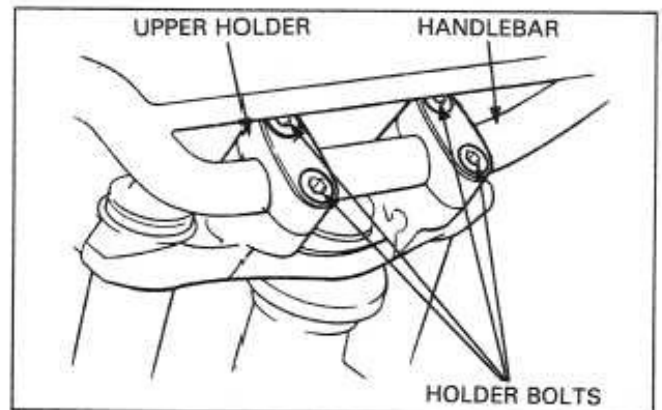
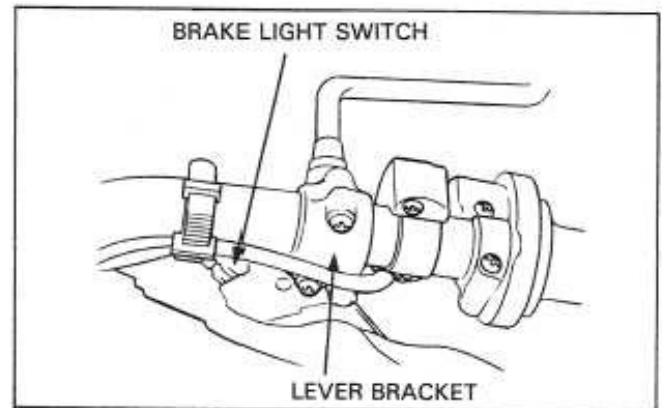
**Installation**

Place the handlebar onto the lower holders, aligning the punch mark on the handlebar with the upper surface of the lower holders.

Install the upper holders with the punch marks facing forward.

Tighten the front bolts first, then the rear, to the specified torque.

Refer to the Model Specific manual for the proper torque value.

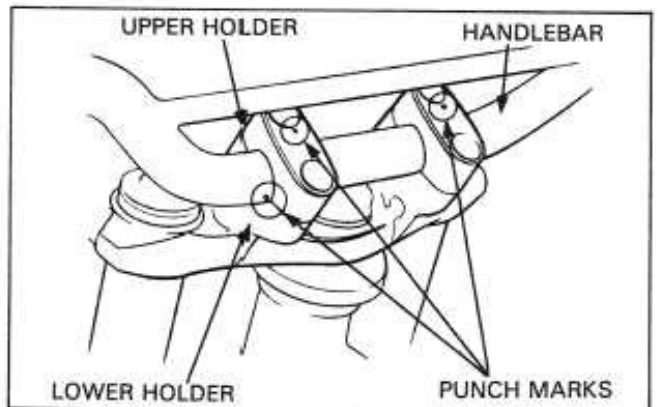

Connect the choke cable to the choke lever.

Install the left handlebar switch, aligning the pin with the hole in the handlebar.

Tighten the forward screw first, then the rear screw.

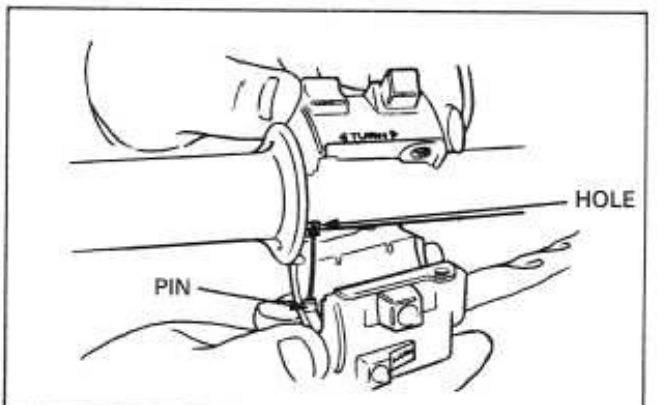

FRONT SUSPENSION

Apply a light coating of grease to the throttle cable ends and throttle grip sliding surface.

Connect the throttle cable to the throttle grip and install the grip to the handlebar.

Install the right handlebar switch, aligning the pin with the hole in the handlebar.

Tighten the forward screw first, then the rear screw. Check that the throttle grip moves smoothly and adjust the throttle grip free play.

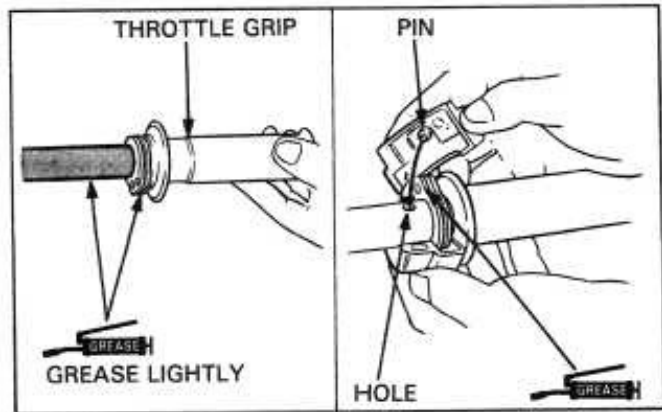

Install the brake lever and clutch lever brackets, aligning the punch marks with:

- cable type: slit in the bracket.
- hydraulic type: master cylinder; set the holder with the holder punch mark facing up.

Tighten the upper bolts first, then the lower bolts.

Route switch wires properly and secure them with bands.

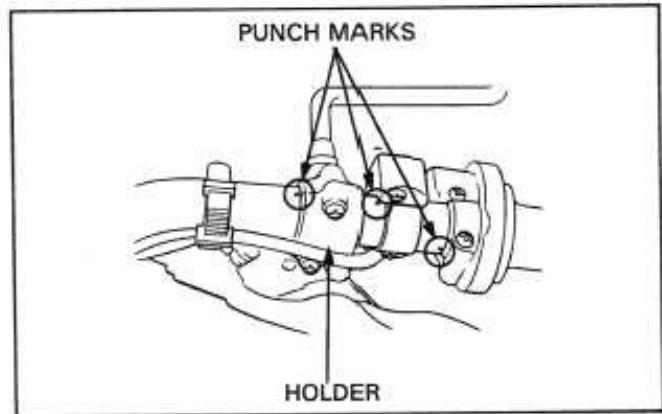

TWO-PIECE, CLAMP-ON TYPE

Removal

Remove the following:

- Both handlebar switches
- Throttle grip
- Master cylinder(s) or lever bracket(s)

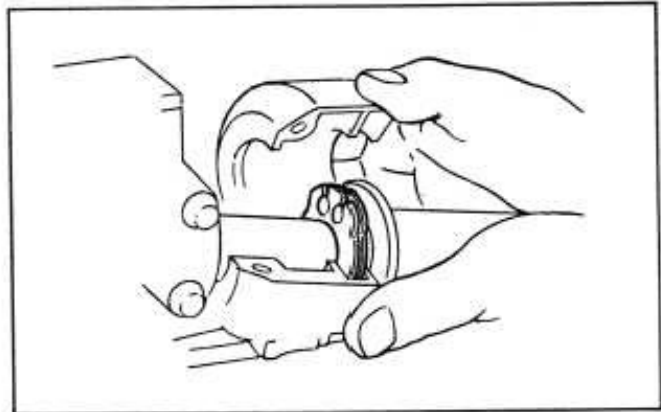

Remove the stop ring.

Remove the pinch bolt and handlebar.

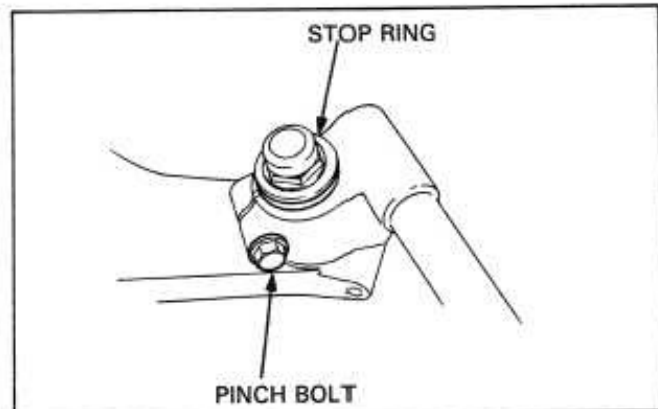

Installation

Install the handlebar by aligning the pin with the top bridge slot.

Install the stop ring into the groove of the fork tube.

Tighten the pinch bolts to the specified torque.

Turn the handlebar through its full range and check that there is no handlebar/steering interference with cables or harnesses, especially throttle and brake cables, hoses and lines.

▲ WARNING

- **Handlebar interference can have an adverse effect on safe vehicle operation.**

Connect the choke cable to the choke lever.

Install the left handlebar switch, aligning the pin with the hole in the handlebar.

Tighten the forward screw first, then the rear screw.

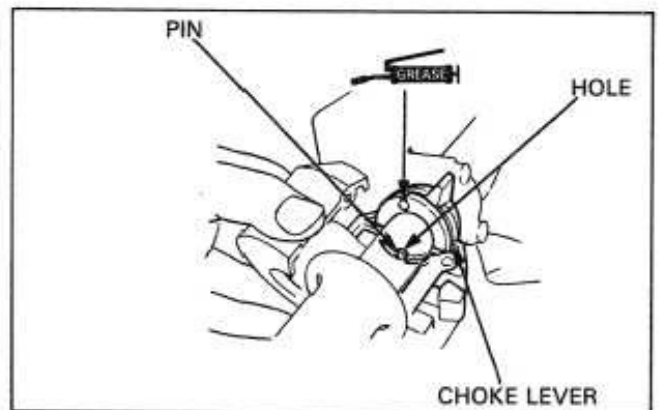
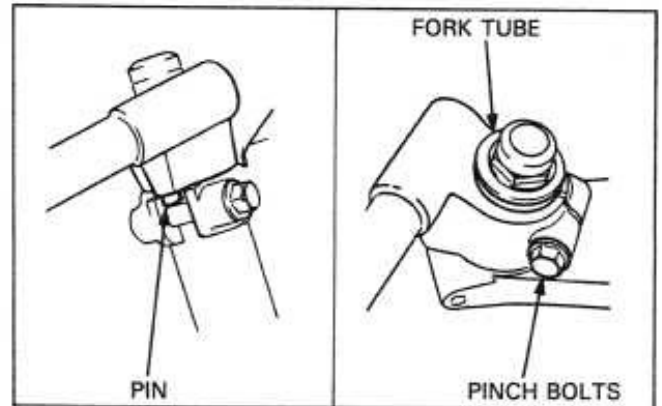

Install the brake lever and clutch lever brackets or both master cylinders by aligning the punch mark on the handlebar with the:

- On cable type: Slit in the lever bracket.
- On hydraulic type: Master cylinder; set the master cylinder holder with the "UP" mark facing up or punch mark facing forward or up.

Tighten the upper or forward bolt first, then tighten the lower or rear bolt to same torque.

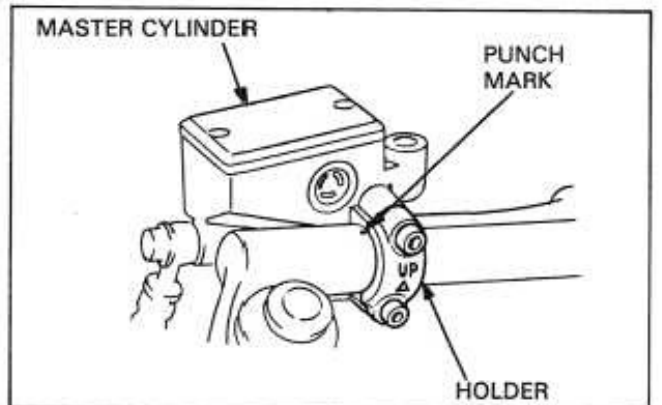

Apply grease to the cable ends and the throttle grip sliding surface.

Connect the throttle cable to the grip and install the throttle grip.

Set the right handlebar switch by aligning the pin with the hole of the handlebar.

Tighten the forward screw first, then the rear screw.

Check that the throttle grip moves smoothly.

Route the wires properly and secure them with wire bands.

Adjust the throttle grip free play.

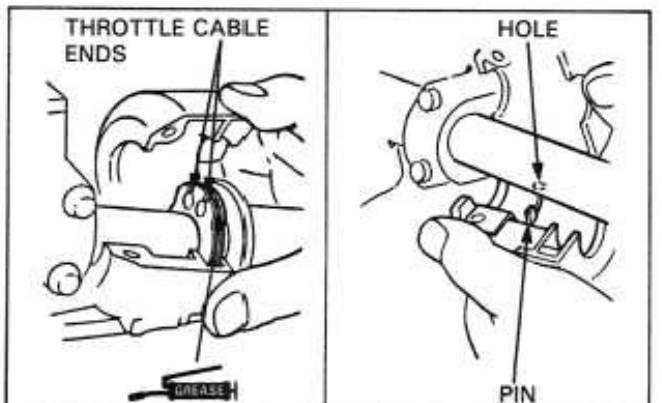

FRONT SUSPENSION

HANDLE GRIP INSTALLATION

If a choke lever is attached to handlebar, it must be installed onto the handlebar before you install the grip.

Apply Honda Bond A or Honda Hand Grip Cement (U.S.A. only) to the inside surfaces of the grips and to the clean surface of the left handlebar and throttle. Wait 3–6 minutes and install the grips. Rotate the grips for even application of the adhesive.

Apply sufficient but not excessive adhesive to the throttle. Excessive adhesive, forced into the interior bore of the drum, will restrict free drum movement on the handlebar.

Allow the adhesive to dry for at least an hour before using.

▲ WARNING

- Any restriction of the throttle can cause a loss of throttle control.

HANDLEBAR WEIGHT REPLACEMENT

End-Type Weights:

Remove the mounting screw and the weight.

Inner-Type Weights:

Remove the handlebar grip:

- Spring pin type:
 - Drive out the spring pin using a pin driver
- Retainer ring type:
 - Straighten the locking tab.

To remove, pull the weight while twisting it.

NOTE

- The inner weight is centered within the bar.

Retainer ring type:

Install a new retainer ring to the inner weight and install the end weight, aligning the cutout.

Insert the weight into the handlebar, and turn the weight to ensure that the locking tab aligns with the hole.

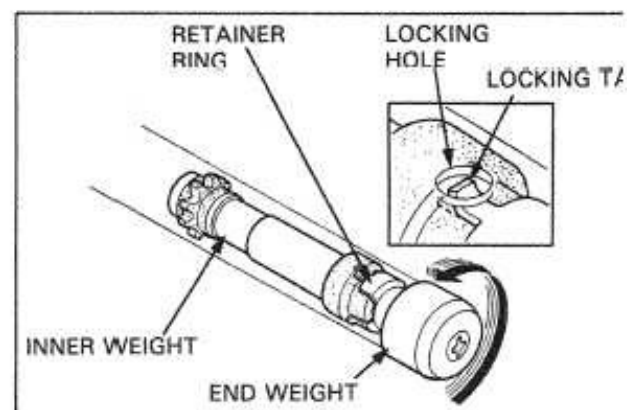
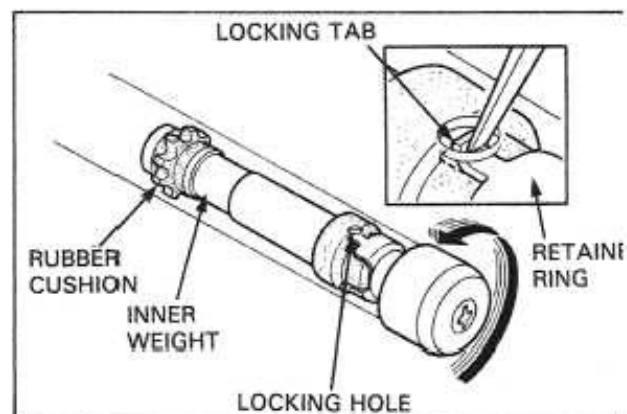
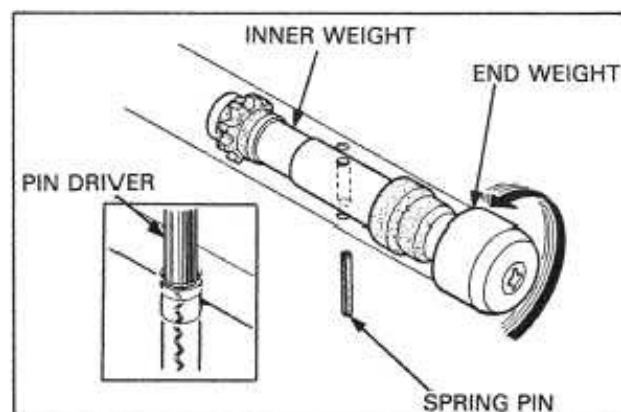
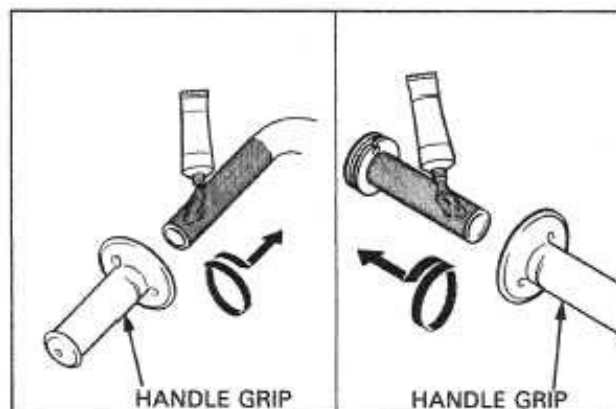

Spring pin type:

Insert the weight into the handlebar and turn it until the spring pin hole is aligned with the hole in the handlebar.

Secure the weight with the spring pin using pin driver.

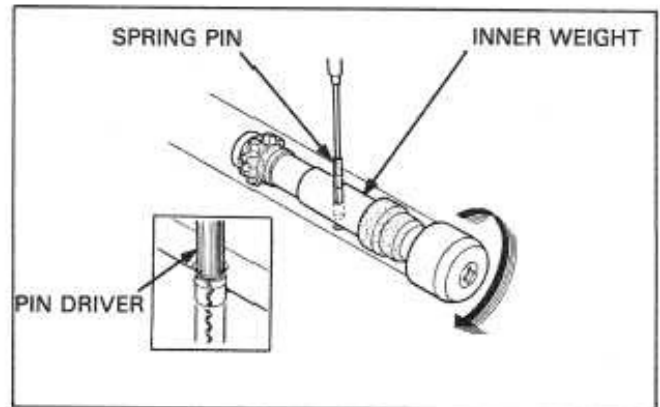

STEERING STEM

If the vehicle has been involved in a collision, the steering stem may be damaged.

REMOVAL

Telescopic Type:

Remove the handlebar.

Remove the ignition switch and/or fuse holder if either are attached to the top fork bridge.

Refer to the Model Specific Manual for specific procedures.

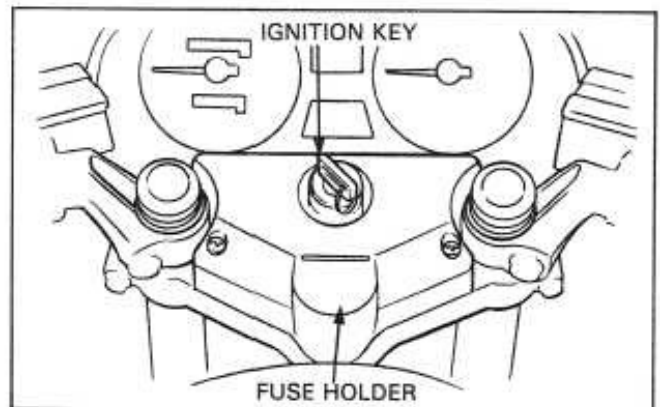

Remove the following:

- Stem nut and washer.
- Front wheel and fork.
- Fork top bridge.
- Horn and/or brake hose joint, if either are attached.

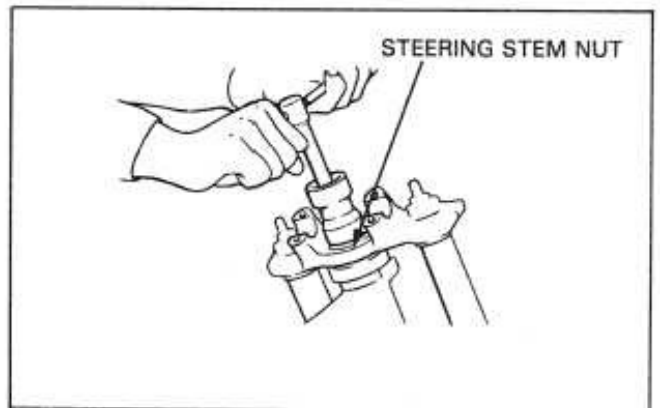

The lock washer tabs must be bent down in order to remove the lock nut.

Remove the lock nut and lock washer.



FRONT SUSPENSION

Remove the steering adjustment nut.

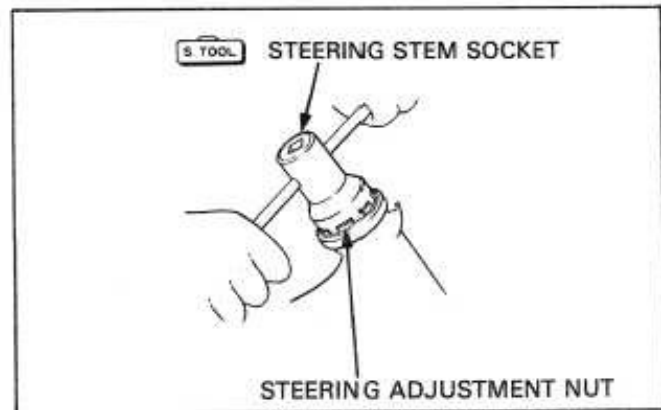

If the bearings are the loose-ball type, place a shop towel under the steering stem to catch the steel balls.

NOTE

- Tapered roller bearings or retained-ball type bearings should be removed from the steering stem after the stem has been removed from the frame.

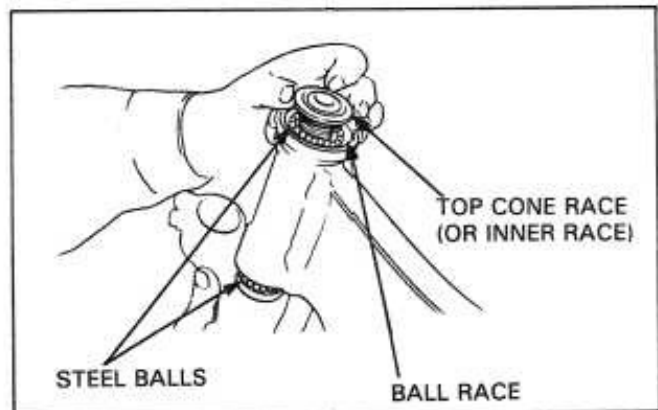

Remove the dust seal and top cone race, or inner race, while holding the steering stem with your other hand. Then remove the steering stem from the frame.

NOTE

- Where loose balls are used, be sure that none of the balls have been lost.

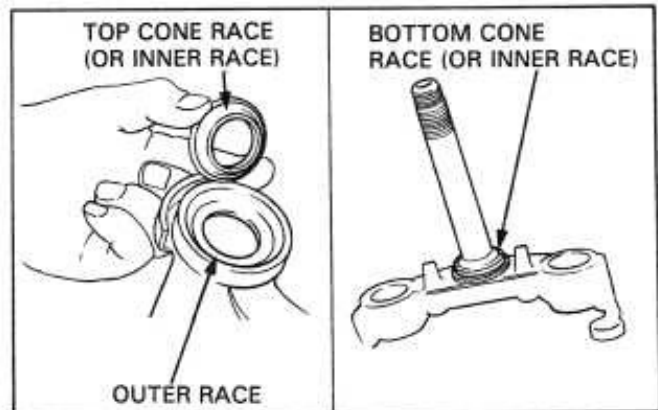

Inspection

Check all of the races and balls for damage or abnormal wear and replace as necessary.

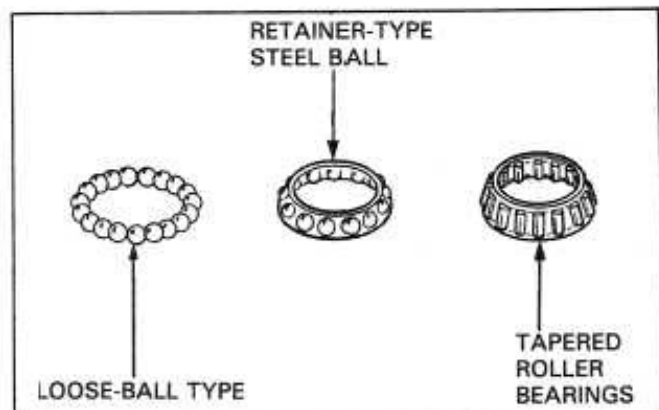

RACE REPLACEMENT

NOTE

- Bearings should be replaced as a set—inner and outer races.
- If the motorcycle has been involved in an accident, examine the area around the steering head for cracks.

Remove the races from the steering head using the ball race remover.

Refer to the Model Specific manual for specific information about tools.

Install new races into the steering head using the driver and attachment.

NOTE

- Drive the races in squarely, making sure that they are fully seated.

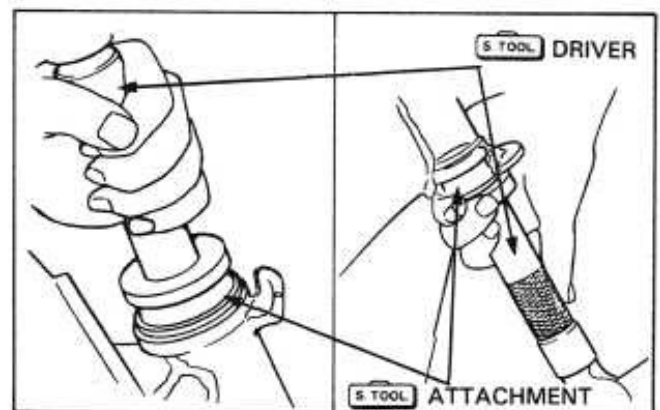
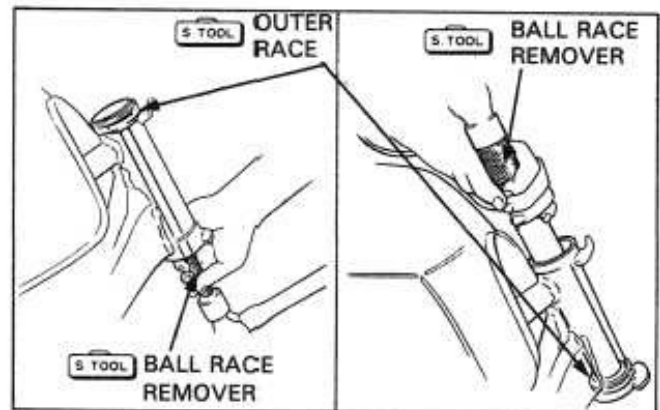

On aluminum frames: replace the races using the Ball Race Remover Set as described in the following procedure.

S TOOL

Ball race remover set (includes (1) thru. (6))

(1) Driver shaft	07946-KM90001
(2) Base	07946-KM90300
(3) Attachment A, 47 mm	07946-KM90600
(4) Attachment B, 55 mm	07946-KM90200
(5) Remover A, 47 mm	07946-KM90401
(6) Remover B, 55 mm	07946-KM90500

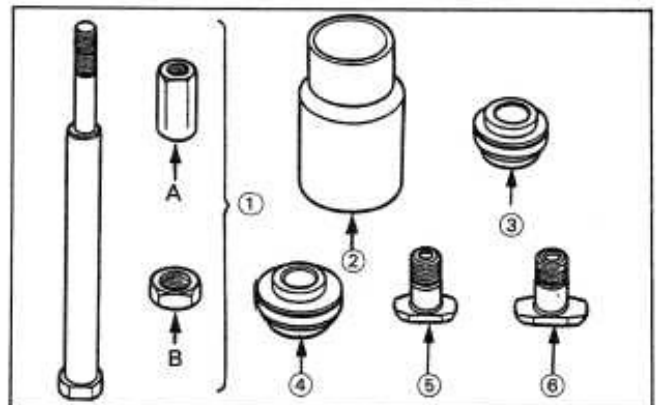

Top Race Removal

Install remover tool A into the steering head and place attachment A onto remover A and secure it with nut B.

Install attachment B onto the Driver shaft and install them through attachment A.

Install the base noting the proper installing direction and screw in nut A.

Set attachment B into the bottom of the steering head.

Hold the driver shaft with a wrench and tighten nut A to remove the upper race.

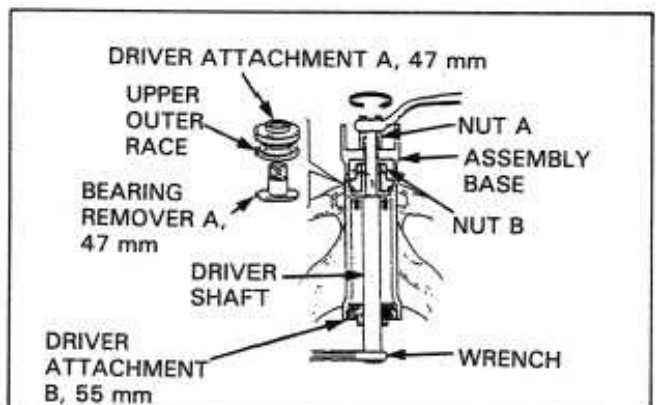

FRONT SUSPENSION

Bottom Race Removal

Set remover B into the steering head, place attachment B onto remover B, and secure it with nut B.

Install attachment A onto the top of the steering head.

Install the remover shaft through attachments A and B and set the base with the big end toward the head pipe and screw in nut A.

Remove the bottom race in the same manner as the top race.

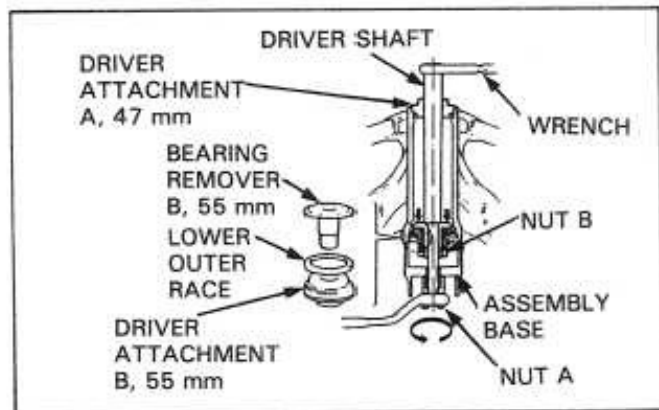

Top Race Installation

Install a new top race and attachment A onto the top of the steering head.

Install the driver shaft, attachment, and base with the small side of the base toward the steering head as shown.

Tighten nut A.

Hold the driver shaft to prevent the new race from turning, and install the top race by turning nut A gradually until the groove of attachment A aligns with the top end of the head pipe.

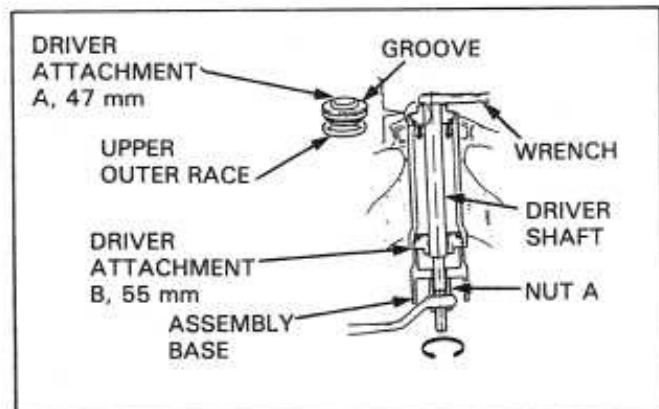

Bottom Race Installation

Install a new bottom race and attachment B onto the driver shaft, and install them into the steering head.

Set attachment A and base on the top of the steering head and tighten nut A.

Hold the driver shaft securely and install the bottom race into the steering head by turning nut A gradually until the groove of the attachment aligns with the bottom of the steering head.

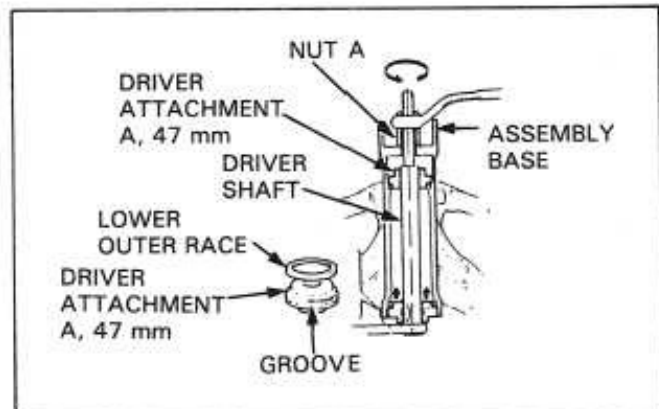

Steering Stem Bottom Race Replacement

Temporarily install the steering stem nut onto the steering stem to prevent damage to the threads.

Remove the bottom race and dust seal using a drift, and discard them.

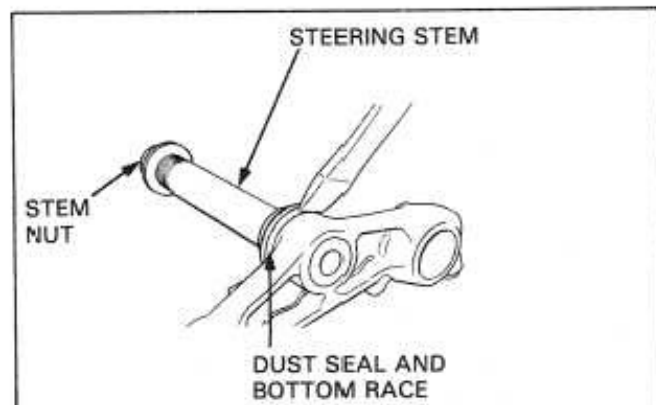

Install a new dust seal and bottom race onto the steering stem.

Press in the bottom race using the steering stem driver and a hydraulic press.

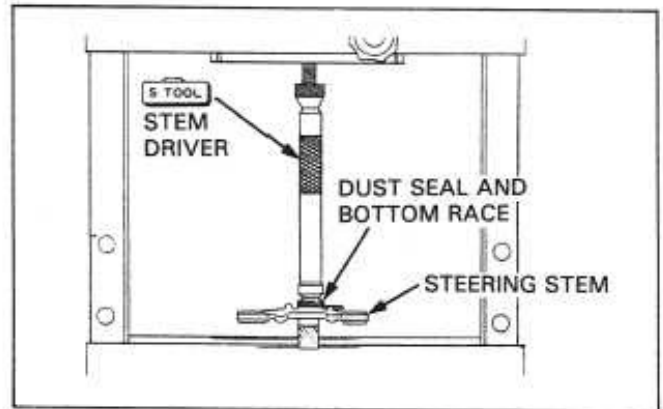

STEERING STEM INSTALLATION

Loose-Ball Type

Apply grease to the top and bottom cone races. Install the steel balls onto the top and bottom races, making sure you have the correct amount.

Insert the steering stem, taking care not to dislodge the steel balls from the grease.

Hold the steering stem in place and install the top cone race and dust seal steering adjustment nut.

Tighten the steering adjustment nut to the proper torque: Refer to the Model Specific manual for this specification.

Turn the steering stem right and left, lock-to-lock, several times to seat the bearings.

Make sure that the steering stem moves smoothly, without play or binding, then loosen the adjustment nut.

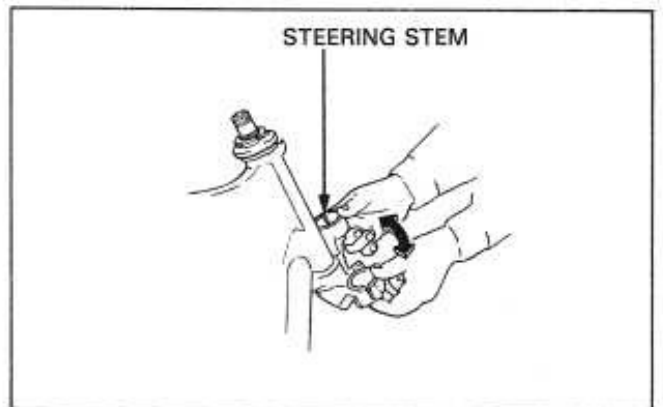
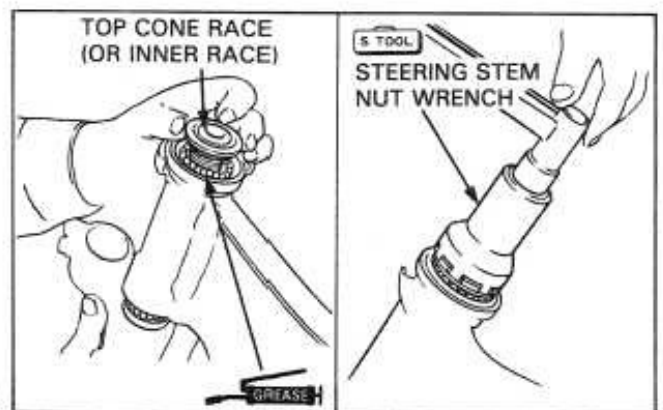

Retighten the steering adjustment nut to 15 N•m(1.5kg-m, 10ft-lb), then loosen the nut 1/8 turn.

Recheck that the steering stem moves smoothly without play or binding.

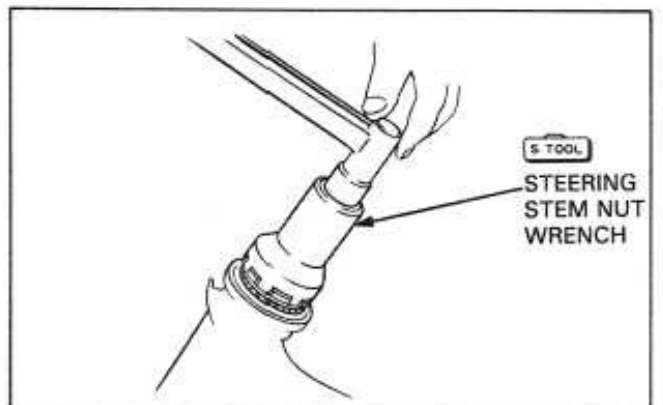

FRONT SUSPENSION

Reinstall the top bridge and fork legs temporarily.

Tighten the stem nut to the specified torque.

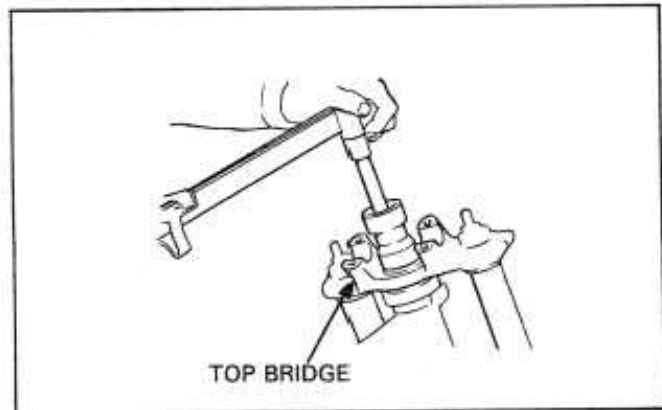

Retainer-Type Ball Bearings

Apply grease to both the top and bottom bearings.

Place the lower bearing onto the steering stem with the retainer facing downward.

Insert the steering stem into the steering head and install the upper bearing into the steering head.

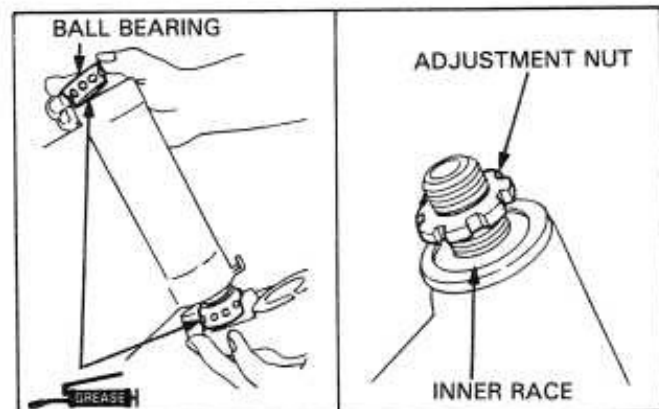

While holding the steering stem with one hand, install the inner race and steering adjustment nut onto the stem.

Tighten the steering adjustment nut to $25 \text{ N} \cdot \text{m}$ (2.5 kg-m, 18 ft-lb).

Turn the steering stem right and left, lock-to-lock, several times to seat the bearings.

Make sure that the steering stem moves smoothly, without play or binding; then loosen the adjustment nut.

Retighten the adjustment nut to $25 \text{ N} \cdot \text{m}$ (2.5 kg-m, 18 ft-lb).

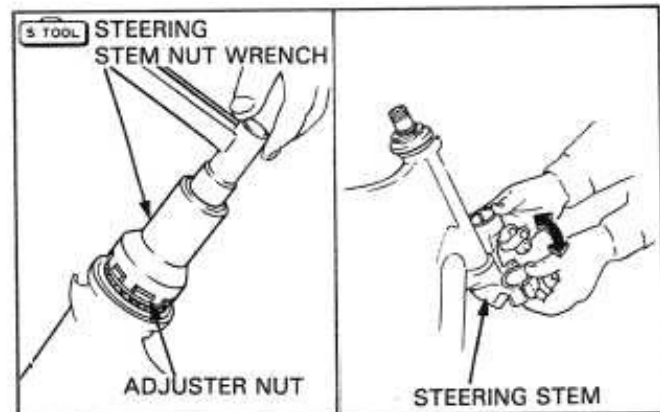

Install a new lock washer by aligning its tabs with the grooves in the adjustment nut.

Screw the lock nut all the way in with your fingers.

Hold the steering adjustment nut and further tighten the lock nut; enough to align the grooves with the lock washer tabs of the lock washer.

Bend the lock washer tabs up into the lock nut grooves.

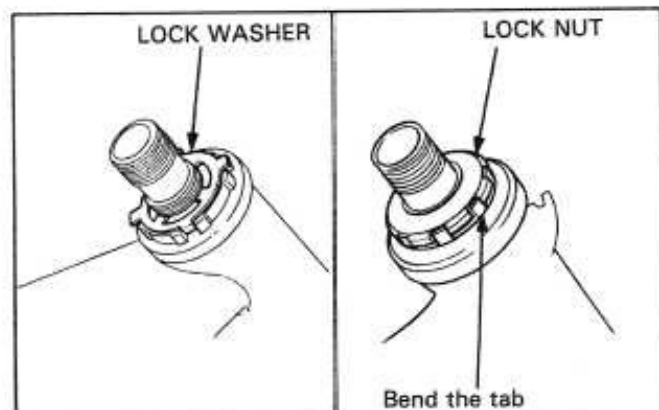

Install the top bridge and temporarily install the fork legs.

Tighten the stem nut to the specified torque.

Check the steering head bearing preload (page 18-22).

Reinstall the removed parts.

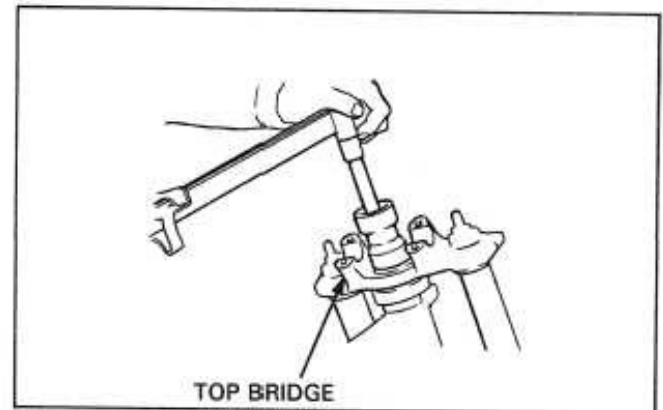

Tapered Roller Bearing Type

Apply grease to the top and bottom bearings.

Install the bottom bearing onto the steering stem with the retainer toward the bottom.

Insert the steering stem into the steering head; then install the top bearing and dust seal (if a seal is used on the particular model).

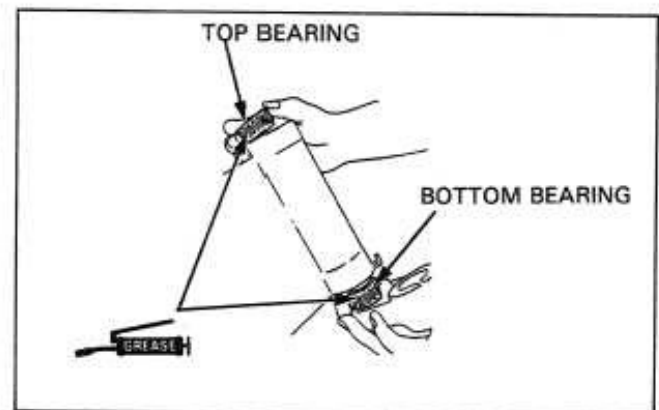

Install steering adjustment nut while holding the steering stem.

Tighten the adjustment nut to 11 N·m (1.1 kg·m, 8 ft·lb).

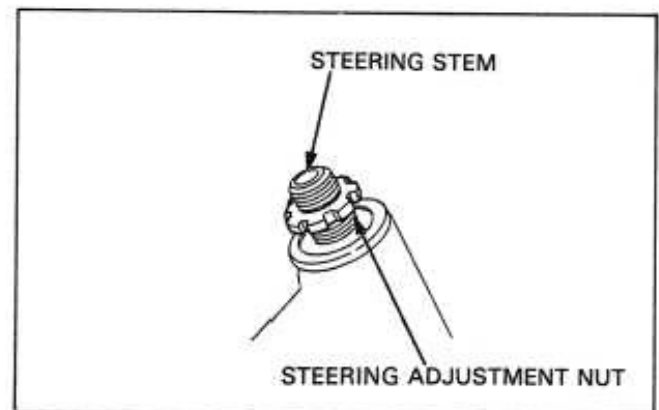

Turn the steering stem right and left, lock-to-lock, several times to seat the bearings.

Make sure that the steering stem moves smoothly, without play or binding.

Retighten the adjustment nut to confirm the torque.

Torque : 11N·m(1.1kg·m, 8 ft·lb).

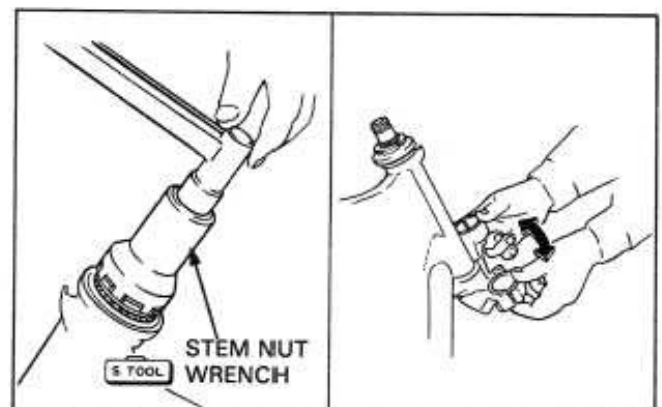

FRONT SUSPENSION

Install the top bridge and temporarily install the fork legs.

Tighten the steering stem nut to the specified torque.

Check the steering head bearing preload.

Reinstall the remaining removed parts.

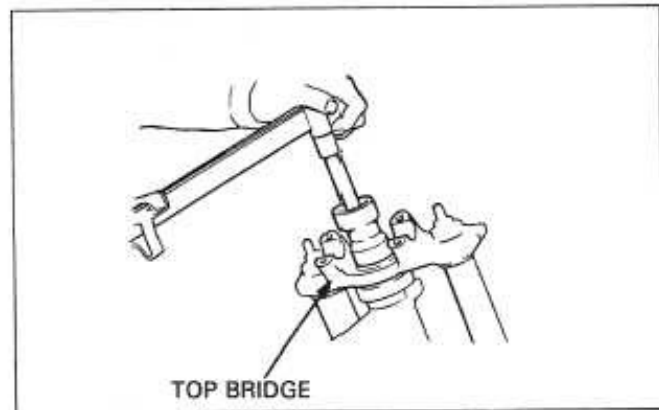

STEERING HEAD BEARING PRELOAD MEASUREMENT

Steering head bearings (applicable to on-road models over 125 cc) that are too loose or too tight may cause handling problems.

After the steering stem and bearings have been reassembled, make sure that the steering head bearings are installed correctly by measuring the preload.

An average measurement is given here, refer to the Model Specific manual for the correct preload specification.

$$\text{Measurement (Reading on spring scale)} = \frac{\text{PRELOAD (kg-m, in-lb)}}{\text{DISTANCE (between stem and fork tube centers)}}$$

kg (lb) 1cm, in)

Example:

Distance: 7.5 cm (3.0 in)

Preload: 15 kg-cm (13.0 in-lb)

Measurement should be 2.0 kg (4.3 lb) on the spring scale.

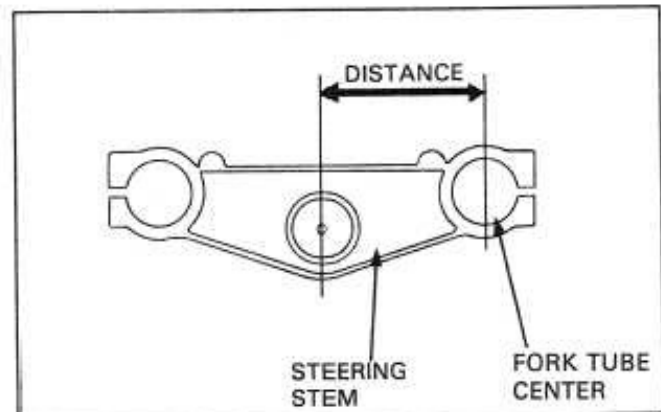

MEASUREMENT

Place a jack or work stand under the engine and raise the front wheel off the ground.

Position the steering stem in the straight ahead position.

Hook the spring scale to a fork tube between the top and bottom bridges.

Pull the spring scale, keeping the scale at a right angle to the steering stem.

Read the scale at the point where the steering stem just starts to move.

Compare this with the specification in the Model Specific manual.

Adjust as necessary.

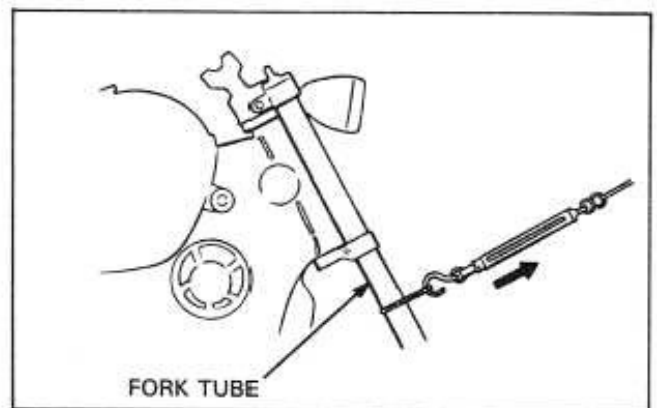
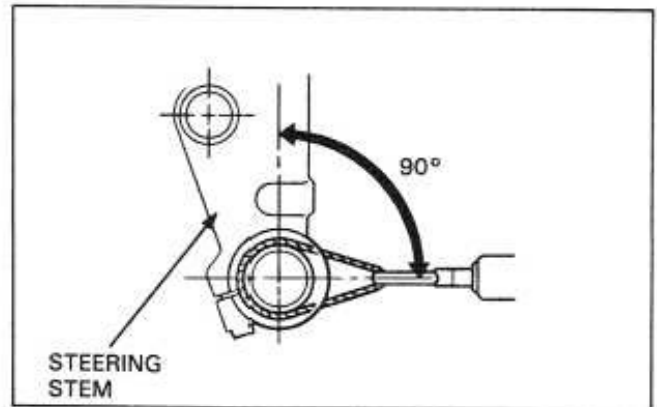

MEMO

19. REAR SUSPENSION

SERVICE INFORMATION	19-1	SHOCK ABSORBER	19-7
TROUBLESHOOTING	19-1	SWINGARM	19-11
SYSTEM DESCRIPTIONS	19-2	PRO-LINK SUSPENSION LINKAGE	19-11

SERVICE INFORMATION

- Use only genuine Honda bolts and nuts on all suspension, swingarm, shock absorber and suspension linkage mounting locations.

▲ WARNING

- Some shock absorber damper units contain nitrogen gas under high pressure. Do not allow fire or heat near the gas containing shock absorber.
- Before disposal of the gas containing shock absorber, release the nitrogen gas (see page 19-9).

TROUBLESHOOTING

Soft Suspension

- Weak spring(s)
- Oil leakage from damper unit
- Air or gas leakage
- Incorrect damper adjustment

Hard Suspension

- Incorrectly mounted suspension components
- Incorrect damper adjustment
- Bent swingarm pivot
- Bent damper rod
- Damaged swingarm pivot bearing(s)
- Faulty suspension linkage
- Damaged linkage pivot bearings

SYSTEM DESCRIPTIONS

Swingarm-type rear suspension systems provide a comfortable ride while offering good traction and wheel control capabilities. Using the front swingarm pivot as the fulcrum and mounting the rear axle at the trailing end of the swingarm allows the wheel to respond quickly to variations in the road or trail surface.

At present, almost all motorcycles have adopted this basic configuration for rear suspension. On some scooters, the entire engine and drive unit pivots as the "swingarm". This basic swingarm type rear suspension design can be broken down into a few categories, depending on the number of dampers used and the design of the swingarm.

Conventional, Dual Spring/Damper Type

In the conventional type system, two spring/damper units support the rear of the frame from the rear section of the swingarm as illustrated here.

Today, this type of suspension is found primarily on small displacement motorcycles because of the simplicity of installation, the small number of components necessary and due to the system's basic economy. Up until around 1981, this dual spring damper design was also used on most larger displacement motorcycles as well.

A rising rate type rear suspension is also possible on dual shock types if the shock angles are correctly positioned.

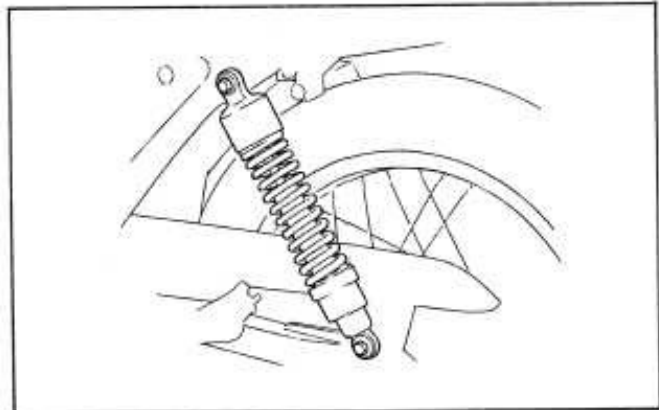

Pro-Link, Progressive Link Type

Honda's Pro-Link suspension system is designed to provide both comfort and control without compromise. Its progressive action rising rate delivers an ideal proportion of springing and damping over a wide range of riding conditions. Initial rates are soft for supple response to small bumps and ripples. Should the riding surface become rougher, increasingly stiffer rates provide the control necessary to prevent bottoming and keep the rear wheel in contact with the surface.

The swingarm and damper unit of the Pro-Link type rear suspension are connected to the swingarm by a link. The damper unit travel in relation to the rear wheel movement can be changed relatively freely during the design stage in accordance with the combination of the cushion arm and cushion connecting rod that is selected.

As the axle stroke distance increases, the piston speed of the damper and shock absorbing force increase progressively. Therefore, this type of suspension is characteristically soft on initial travel so it absorbs small riding surface inconsistencies well, and provides progressively firmer resistance to prevent bottoming at full compression when a large bump is hit.

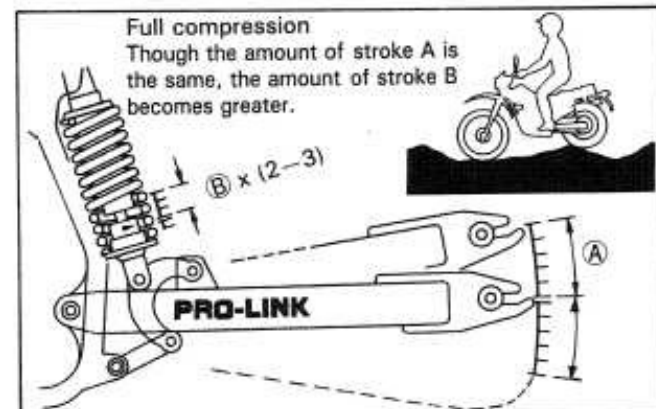
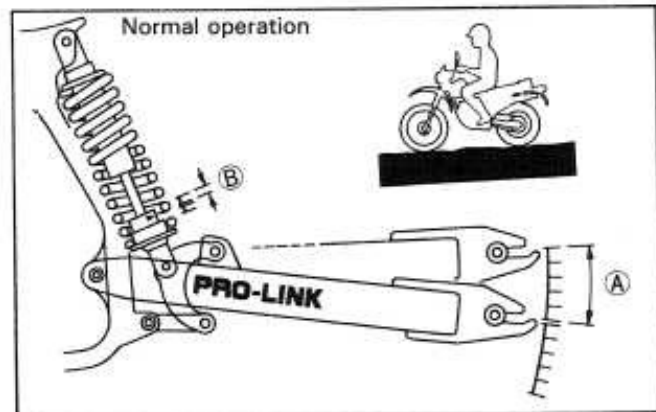

This arrangement offers a greater amount of suspension stroke compared to the amount the damper unit compresses and, therefore, greater control for improved suspension performance. It also enables the weight of the spring/damper unit to be centralized more compactly, nearer the center of the frame.

The Delta type Pro-Link is a further refinement which lowers the motorcycle's CG by a significant amount, and reduces the weight of the cushion arm.

Pro-Arm Type

Honda's unique cantilever-type Pro-Arm is a functional and stylish departure from the conventional forked-type swingarms. High rigidity and durability are achieved through the use of a massive box-section design and large diameter "axle". The "center pin" mounting allows easy wheel removal/installation, and the design of the eccentric bearing carrier makes chain adjusting easy and wheel alignment foolproof. Other benefits include minimal unsprung weight, added room for compact exhaust routing, slimmer overall machine shape, easier access for damper adjustments, and the simple design lends itself to ease of maintenance and cleaning.

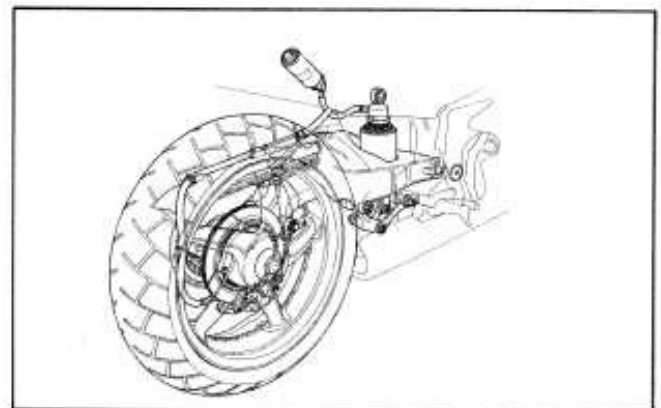

Damper Design and Operation

Riding comfort and proper rear wheel traction are provided by a combination spring/damper unit, and to some degree, by maintaining proper tire pressure. The damper absorbs some suspension compression force and controls the unwanted rebounding effects of the spring. Typically, comparatively little damping resistance is offered on the compression stroke as most of this (shock) is handled by the spring.

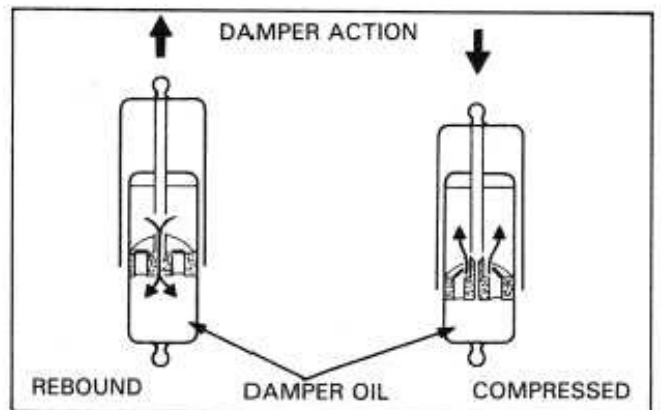

Oil dampers units are either the upside down type or the right side up type. Running the damper body upside down (with the shaft below and the body above) reduces unsprung weight.

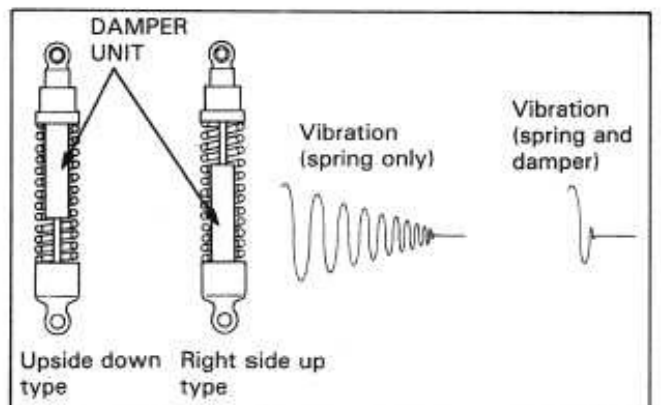

REAR SUSPENSION

In addition to the inverted and conventional damper body types, there are two basic damper designs, each named for the method used to create the damping action; the friction type and the oil damper type.

The friction type damper is comparatively simple in design and is used on only the most lightweight and economical models. This design uses only the friction of a nonmetallic piston against the greased, inside wall of the damper cylinder to counteract the natural rebounding action of the springs.

Many of the simplest and most lightweight motorcycles and scooters are equipped with single damping or single-effect type dampers. This design provides damping force only on the rebound stroke and relies on the compression resistance of the spring alone to absorb riding surface irregularities.

The most effective damper design is the double damping or double-effect type. In these, damping force is provided for both compression and rebound strokes.

Some damper designs include nitrogen gas within their bodies or within a reservoir to prevent the oil from foaming.

In emulsion type dampers the nitrogen is housed in the damper body. Some emulsion-types include a separator in the gas chamber to prevent the gas from mixing with the oil.

Decarbon design dampers keep the nitrogen gas separated from the oil by means of a free floating piston which acts as a diaphragm. This way the oil can pass through the damping orifices without interference from the gas bubbles.

Reservoir equipped dampers are a variation of the simplest Decarbon design. A more consistent oil temperature, and therefore more consistent damping, is provided due to an increased oil capacity; the shock body can be entirely filled with oil since the gas chamber is elsewhere. A rubber bladder is used within the reservoir to separate the nitrogen gas from the damper oil.

DOUBLE DAMPING (DOUBLE-EFFECT) TYPE



EMULSION TYPE

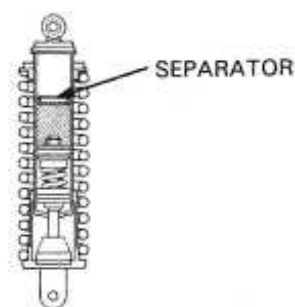

DECARBON TYPE

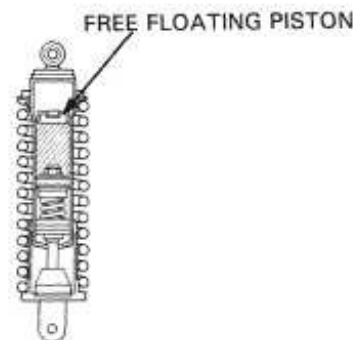

RESERVE-TANK TYPE

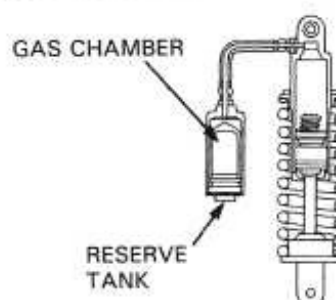

Rear Damper Springs

A variety of spring designs are used on motorcycles and scooters. Among these types are straight wound, progressive wound, wide pitch and narrow pitch, and even tapered spring wire types. Each provides different compressive force characteristics.

NOTE

- Unsprung weight is reduced slightly when the widely pitched (or spaced) spring coils are positioned toward the swingarm.

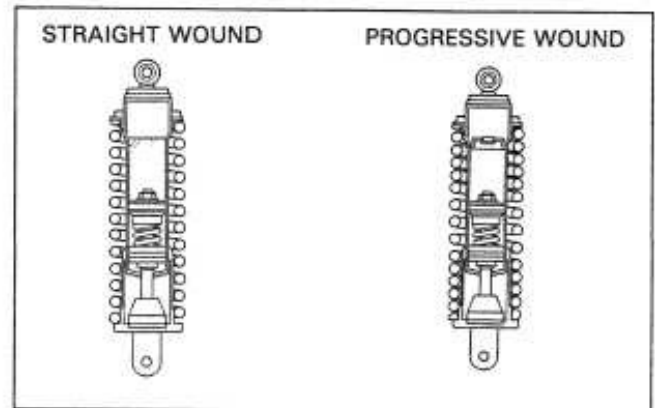

One means of achieving a progressive overall spring rate is to allow the spring rates of two or three different springs to "crossover" or combine their individual qualities by simply stacking the springs atop one another. This method is known as a combination type spring arrangement.

Another variation towards achieving a progressive spring action is to add an air-assist bladder to the spring/damper unit. On these types, air pressure is added up to a specified amount to compensate for increased load requirements rather than adjusting the preload on the spring.

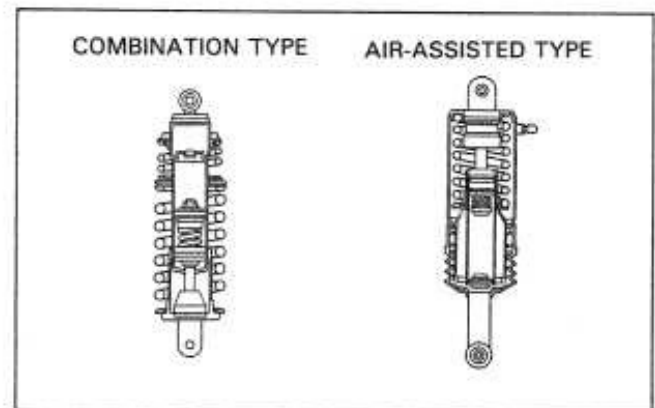

The right "shock" on GL1500s is actually only an "air spring". It has no dampening properties aside from a very slight seal friction and is filled with only a very small amount of oil to lubricate its shaft and oil seal.

Spring Preload Adjuster Designs

The spring adjuster changes the coil spring length and the initial spring preload. There are several types of spring preload adjuster systems; pre-set type, mechanical type and both mechanical and hydraulic remote control types, all of which adjust the spring seat position.

The Pre-set category includes both the cam type preload adjuster and the near infinitely adjustable threaded, double locking nut type.

Cam Type

The cam type preload adjuster uses a collar with recessed steps that fits around the damper body. As each step is positioned against a stop or pair of stops built-in to the damper body, the spring preload can be adjusted to from three to five pre-set positions, to better suit vehicle load requirements.

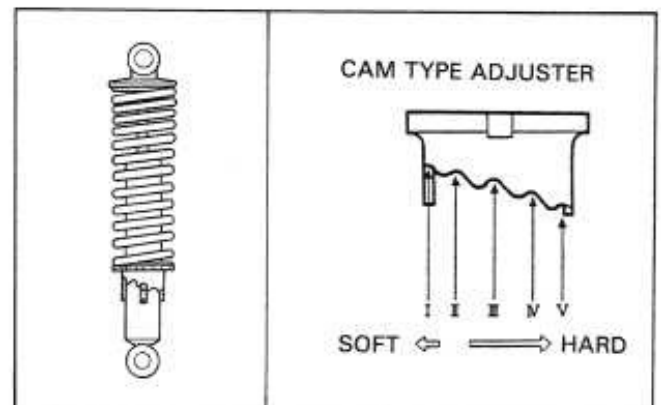

REAR SUSPENSION

Threaded Type

Spring preload is set by moving an adjuster nut to either compress or extend the height of the spring. Once the desired preload is established, a lock nut is tightened against the adjuster nut to prevent it from changing position. A minimum and maximum spring height (spring preload) is recommended for each model. These dimensions must be complied with.

Failure to comply with the minimum and maximum spring length specifications may result in the spring coil binding near full suspension compression or the spring perch retainers coming loose near full suspension extension.

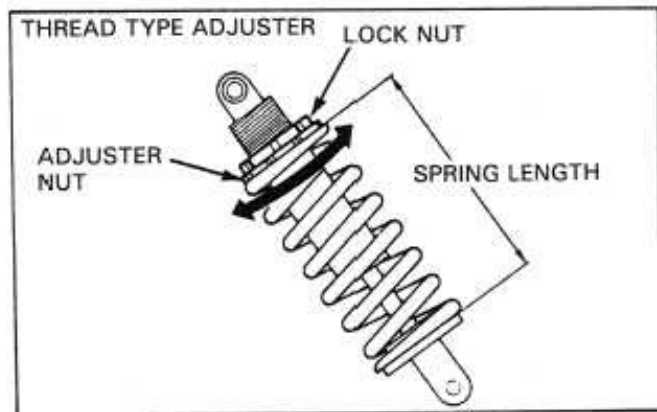

Remote Control Type

The remote type of spring preload adjuster uses hydraulic pressure to reposition the spring seat. An adjuster knob on a conveniently located control mechanism presses against a diaphragm, which in turn forces hydraulic fluid through a line to the damper unit. This hydraulic system, completely separate from the damping system, increases or decreases the height of the spring to achieve the desired preload.

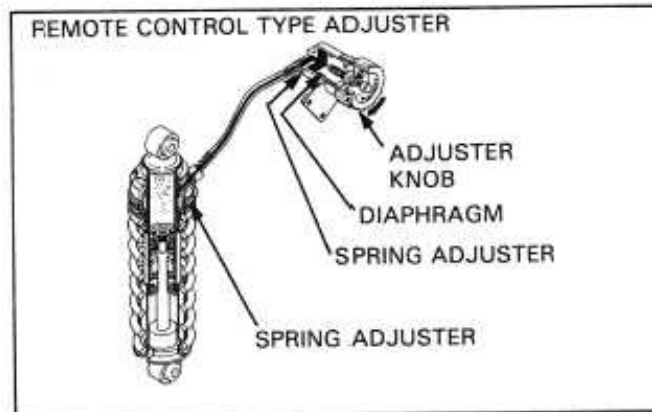

Damping adjuster

In oil damper units, a damping adjuster serves to control the oil flow by regulating the orifice diameter.

On certain types other than those shown in the drawings, the damping force is controlled by adjusting the pre-set load on the valve.

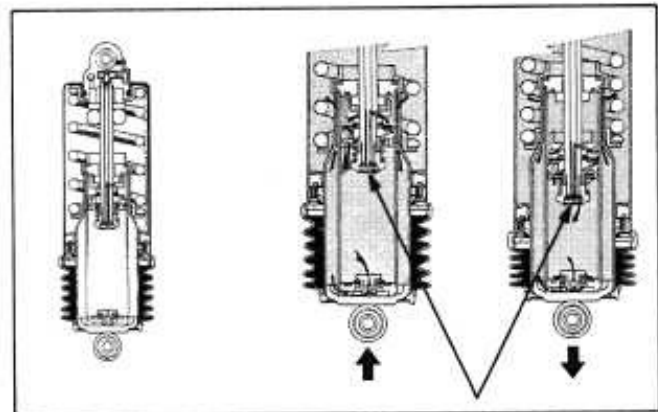

Decreasing the orifice diameter increases resistance and damper hardness.

Increasing the orifice diameter decreases resistance and damper hardness.

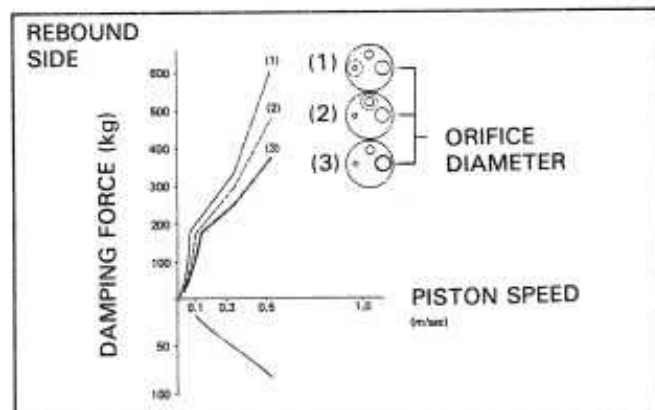

SHOCK ABSORBER

REMOVAL

Support the vehicle securely and raise the rear wheel off the ground.

Remove the mounting bolt(s) or nut(s), then remove the shock absorber.

INSTALLATION

Install the shock absorber on the upper mount, noting the proper installation direction of the mounting hardware.

Raise the rear wheel enough to allow installation of the lower mounts. Slip the mounts into position.

Tighten the upper and lower mounts to the specified torque.

On Pro-Link or Pro-Arm systems, refer to the Model Specific manual for shock absorber removal/installation procedures.

DISASSEMBLY(FOR APPROPRIATE MODELS ONLY)

▲ WARNING

- Certain types of damper units are filled with high pressure nitrogen gas.
- Do not disassemble gas damper units.
- Be sure to release the gas from the damper unit before discarding it.
- To prevent loss of tension, do not compress the spring more than necessary to remove it.

Remove the shock absorber. Compress the spring and remove the damper unit.

Shock Absorber Compressor Use:

Install the shock absorber compressor on the rear shock.

Certain shock absorber compressors require adapters when the attachment is installed, while others do not. Refer to the Mode Specific manual for compressor specifics.

Install the shock absorber compressor holder securely onto the spring end that is near the lock nut or stopper ring. Turn the compressor handle and slowly compress the spring.

Hydraulic Press Use:

Install the spring compressor attachment and compress the spring with the hydraulic press.

Always use a specified tool to compress the spring. Refer to the Model Specific manual.

▲ WARNING

- Compressing the spring improperly could cause serious injury.

Certain types of shock absorbers are mounted with a stopper ring while other types are mounted with a lock nut. Refer to the Model Specific manual.

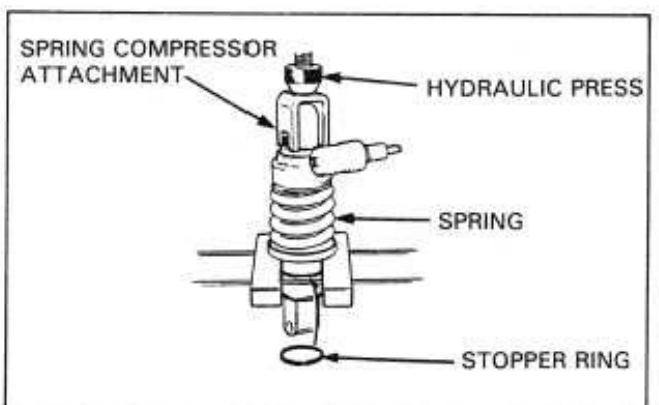
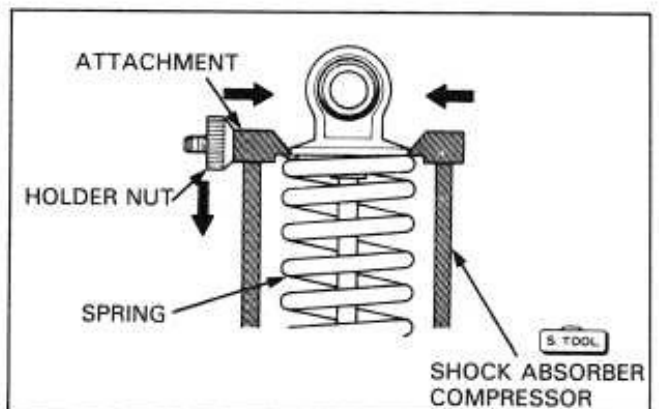
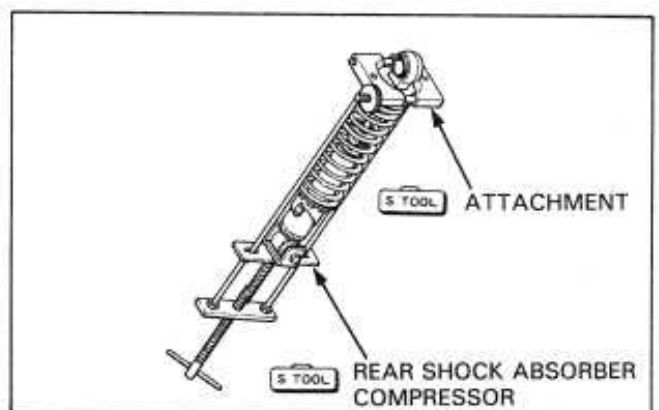
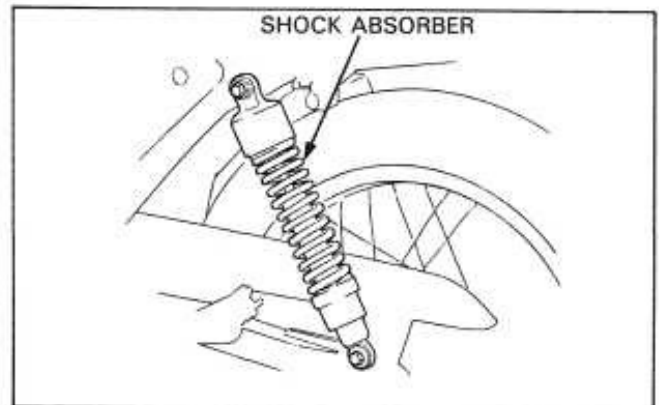

REAR SUSPENSION

Lock Nut Removal

Do not loosen or remove the lock nut if it is staked.

⚠ WARNING

- Loosening or removing a staked lock nut may cause a shock assembly to come apart unexpectedly and lead to a serious injury.

Compress the spring and loosen the lock nut, then remove the upper or lower joint and the spring.

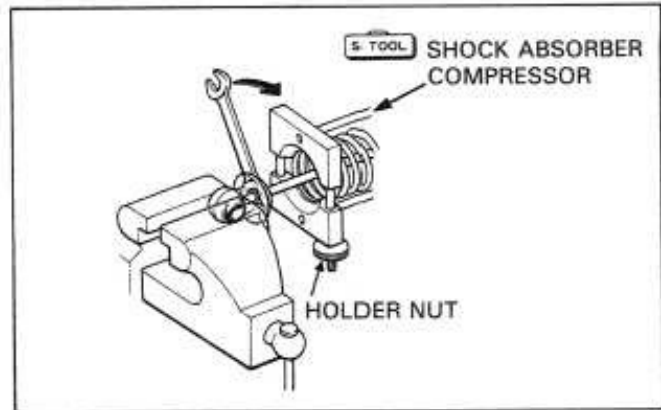

Stop Ring Removal

Compress the spring and remove the stopper ring.

Remove the spring.

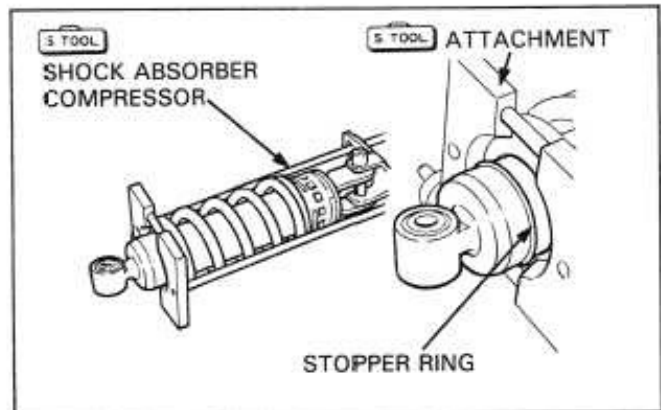

INSPECTION

Spring

Place the spring on a level surface and measure the free length.

Replace the spring if it is deformed, cracked, or if its free length is shorter than the service limit.

Damper Unit

Keep a gas-filled shock absorber away from fire or heat.

⚠ WARNING

- Heating a gas-filled damper can lead to an explosive release of pressure which can cause a serious injury.
- Do not try to disassemble the damper unit if the disassembly procedure is not described in the Model Specific Manual. Disassembly can lead to a release of gas under high-pressure which can cause an injury.

Check the damper unit for deformation or oil leakage and replace if necessary.

Check the damper rod for straightness. Also check for stepped wear and replace if necessary.

Check the damper bump rubber for fatigue or damage and replace if necessary.

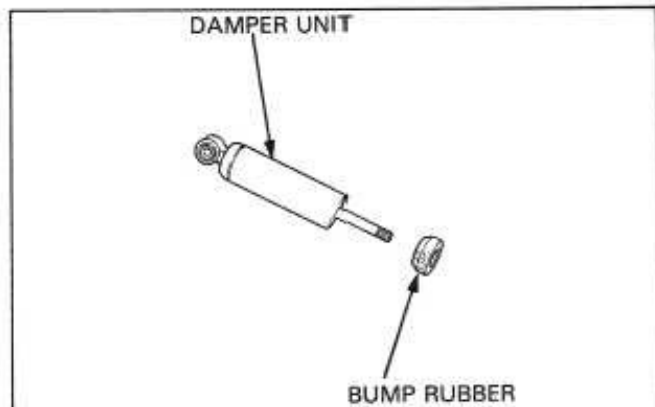
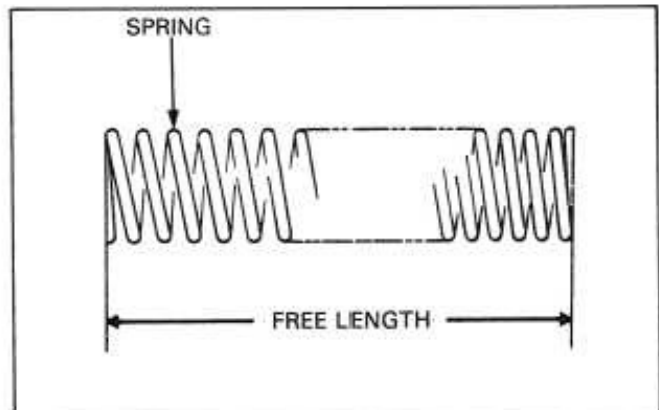

Compression Force (Gas Filled Damper Only)

Examine the damper rod and replace the damper unit if the rod is bent or scored.

Mark the damper rod to indicate the specified compressed stroke (i.e., 10 mm/0.4 in to indicate the from the damper body).

Place the damper rod on a scale and measure the force required to compress the damper until the mark is flush with the damper body.

Refer to the Model Specific manual for the compression force and the specified compressed stroke.

If the force required is less than service limit, the damper is leaking.

Check the upper joint and collar for wear or damage and replace the parts if necessary.

Check the rubber bushing for wear or damage and replace it if necessary.

NOTE

- Apply the specified grease to the sliding surfaces of the collar and bushing, and reinstall them.
- If a needle roller and spherical bearing are installed instead of the bushing and collar, refer to the Model Specific manual for replacement procedures.

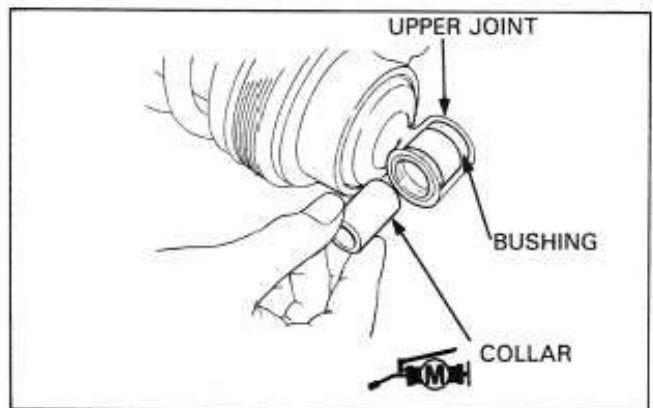
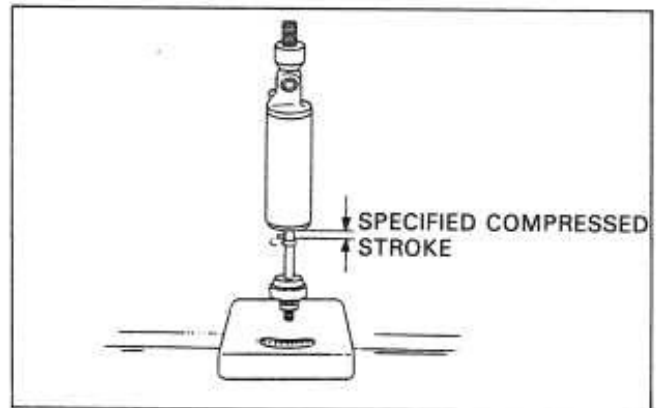

SHOCK ABSORBER DISPOSAL PROCEDURE

Center punch the damper case to mark the drilling point. Refer to the Model Specific manual for the precise drilling point.

Place the damper unit inside a plastic bag and clamp it upright in a vise.

Through the open end of the bag, insert a drill motor with a sharp 2-3 mm (5/64 - 1/8 in) drill bit. Wrap the bag around the drill and hold it closed.

Use a sharp drill bit to minimize heat buildup.

▲ WARNING

- Using a dull drill bit allows a build-up of excessive heat and pressure inside the damper which may cause an explosion.
- The shock absorber contains nitrogen gas and oil under high pressure. Drilling farther into the damper case than specified can puncture the oil chamber. Oil escaping under high pressure may cause serious injury.
- Always wear eye protection to avoid getting metal shavings in your eyes when gas pressure is released.

NOTE

- The plastic bag is only intended to shield you from the escaping gas.

Briefly run the drill motor inside the bag; this will inflate the bag with air from the motor and help keep the bag from getting caught in the bit when you start.

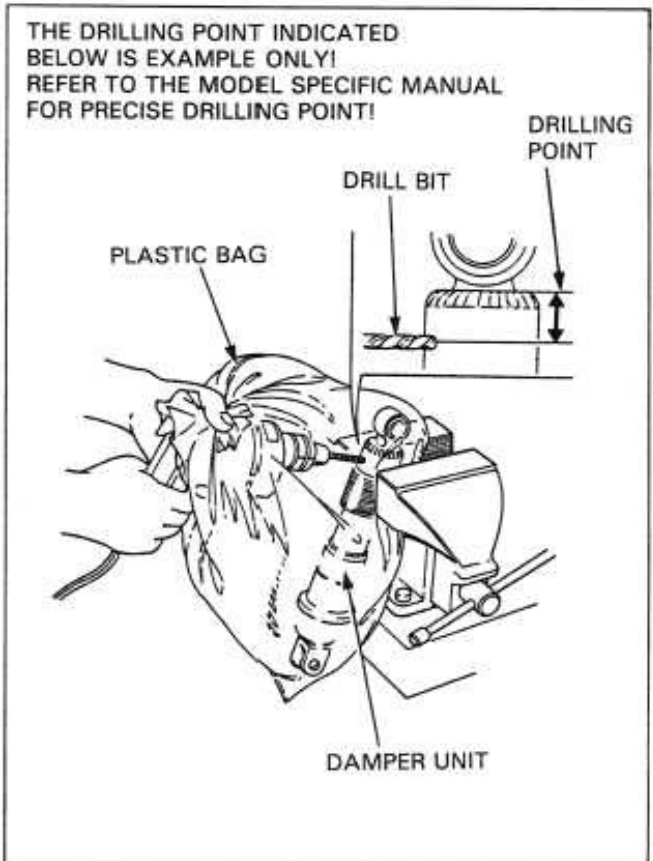

REAR SUSPENSION

For dampers with nitrogen gas filler valve, depress the valve core to release the nitrogen and then remove the valve from the shock absorber.

Point the valve away from you.

▲ WARNING

- Always wear eye protection to avoid getting debris in your eyes.

ASSEMBLY (FOR APPROPRIATE MODELS ONLY)

Assemble the shock absorber in the reverse order of disassembly.

NOTE

- If the shock absorber does not have an even pitch spring, the spring should be installed as specified in the Model Specific manual.

Hydraulic Press Use:

Compress the spring until the stopper ring can be installed using a hydraulic press. Refer to the Model Specific manual.

Always use a Shock Absorber Spring Compressor to compress the spring on dampers with a rod screwed into the upper or lower joint.

▲ WARNING

- Use of a hydraulic press to compress the spring can lead to the spring or shock absorber flying out of the press and causing a serious injury.

Install the stopper ring in the groove in the damper. Be certain that the stopper ring is seated firmly in the groove.

▲ WARNING

- Failure to firmly seat the snap ring may cause the shock assembly to come apart unexpectedly and lead to a serious injury.
- Compressing the spring more than necessary may cause a loss of spring tension.

Joint Installation:

Clean the lock nut threads before installing the lower joint.

Install the lock nut on the damper rod and tighten it by hand as far as it will go.

Apply a locking agent to the damper rod threads.

Install the lower joint on the damper unit.

Hold the lower joint and tighten the lock nut to the specified torque.

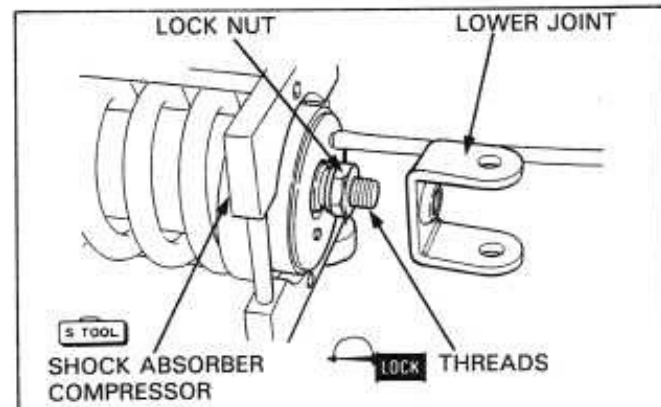
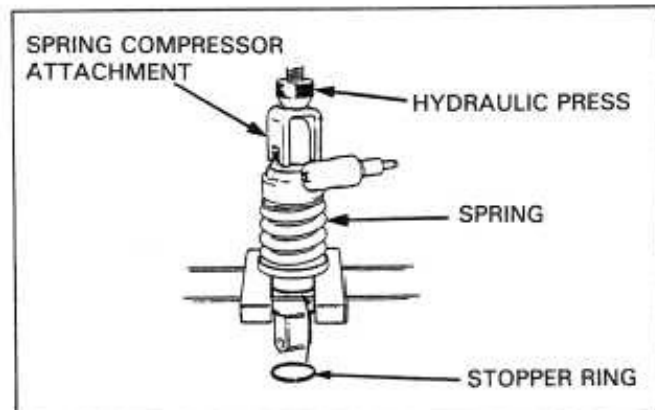
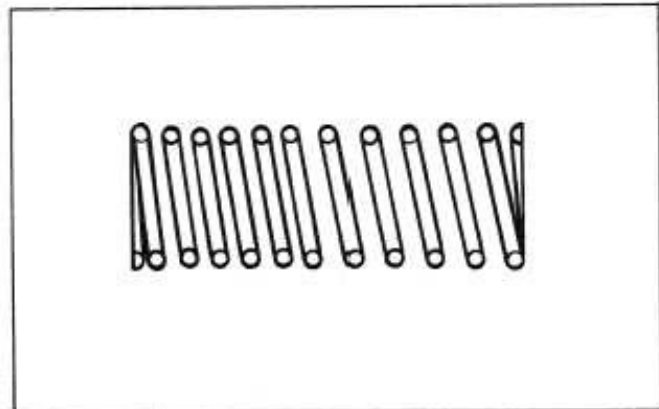
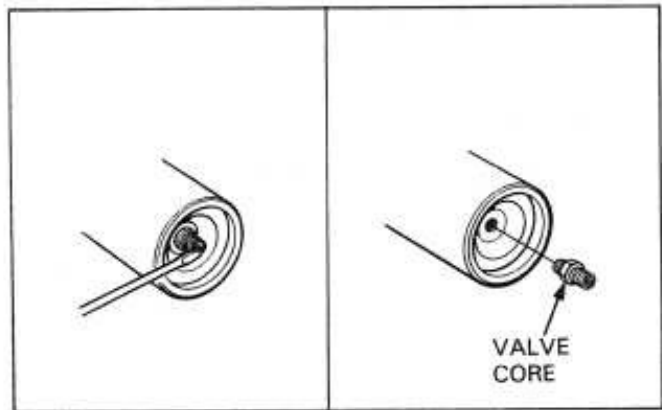

SWINGARM

Refer to the Model Specific manual for swing-arm removal, disassembly, reassembly and installation.

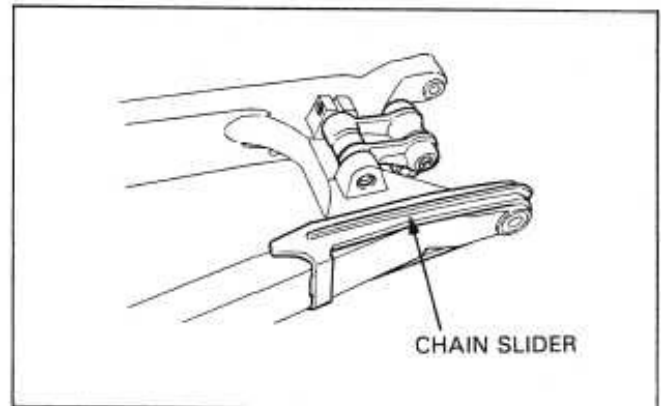

INSPECTION

Remove the chain slider, chain guide and brake torque rod (if installed).

If the motorcycle is a shaft-drive type, remove the rubber boot.

Check the removed parts for wear or damage and replace parts if necessary.

Check the center collar/distance collar, if installed, for wear, scoring or scratches and replace if necessary.

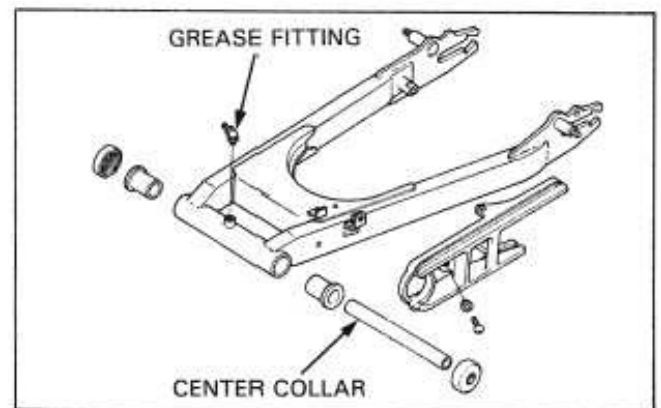

PRO-LINK SUSPENSION LINKAGE

NOTE

- Mark installed position codes on the suspension linkage parts before disassembly. The shock arm and connecting rod often have specific installation directions and they should be installed properly. They may interfere with the frame and/or change the vehicle height unless installed properly.

REMOVAL

Remove the following:

- Rear wheel
- Bolts from the frame side of the connecting rod
- Rear shock absorber lower mounting bolts
- Bolts from the swingarm side of the shock arm

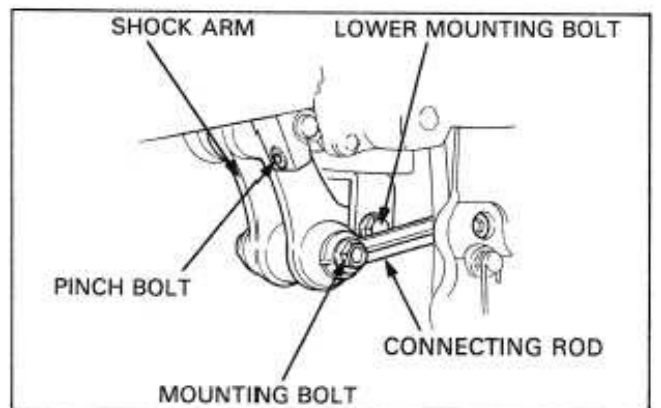

INSPECTION

Check the shock arm and connecting rod for deformation, cracks or other damage and replace as necessary.

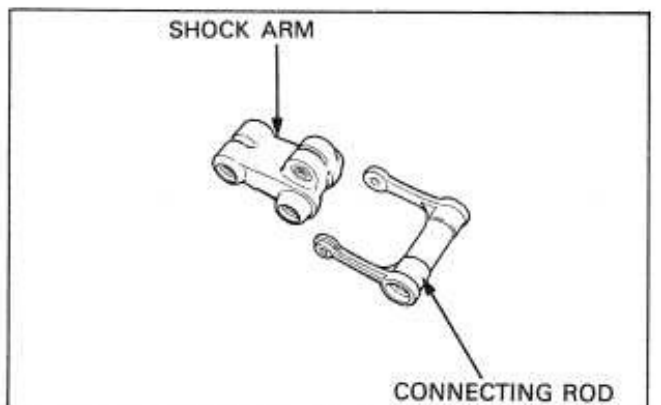

REAR SUSPENSION

Check the pivot collars, dust seals, bushings and/or bearings for wear or damage and replace parts if necessary. Refer to the Model Specific manual for replacement procedures.

Refer to the Model Specific manual, if your motorcycle is equipped with needle roller or spherical bearings.

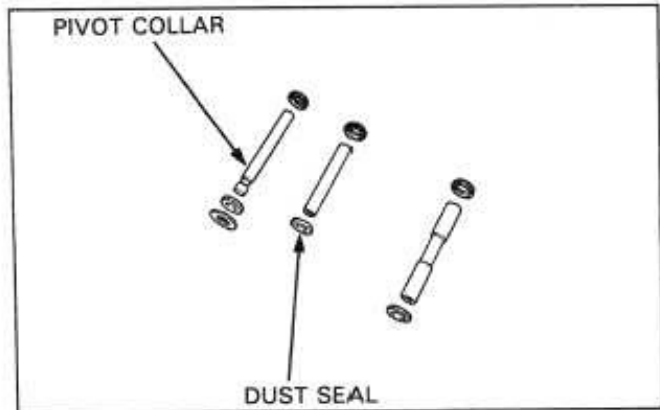

INSTALLATION

Apply molybdenum disulfide grease to all pivot points.

Pack the grease fittings (if installed) with grease.

Reassemble the suspension linkage with special attention to the proper installation directions, and loosely tighten the pivot bolts.

Reinstall the suspension linkage assembly on to the frame and tighten each bolt to the specified torque.

Refer to the Model Specific manual for the proper torque specifications.

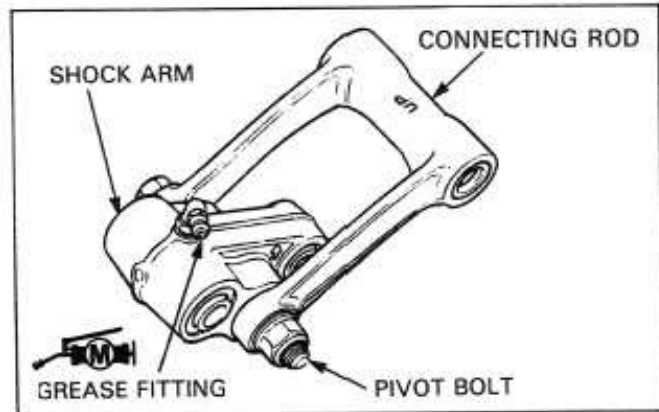

20. FRAME/BODY PANELS

SERVICE INFORMATION	20-1	DESCRIPTION	20-2
TROUBLESHOOTING	20-1	INSPECTION	20-4

SERVICE INFORMATION

- Although it is possible to weld some cracked frames and straighten some frames that are slightly bent, it is best to replace the frame with a new one when it is damaged.
- Generally speaking, plastic body panels cannot be repaired and, therefore, must be replaced.
- It is possible that a front end collision will bend the steering head, but not the fork, wheel, or even the axle.

TROUBLESHOOTING

- Failure of the front suspension, steering, or rear suspension may damage the frame enough to require replacement.
- Refer to section 18 for front suspension and steering inspections.
- Refer to section 19 for rear suspension inspection.

Abnormal engine vibration

- Cracked or damaged engine mounts
- Cracked, damaged or bent welded portions
- Bent or damaged frame
- Engine problems

Abnormal noise when riding (banging or creaking)

- Damaged or bent engine mounts
- Damaged welded points
- Damaged or bent frame

Steers to one side when under acceleration or deceleration

- Bent frame
- Bent fork
- Bent swingarm

DESCRIPTION

Motorcycle, scooter and ATV frames serve as a skeleton to which all other components are attached. Various forms and intensities of vibration and stress from both the engine and the suspension act against the frame when the vehicle is in use. These forces are major factors in determining the final design of each frame.

The various frame designs can be classified into one of a few general categories. Certain types are chosen for particular models according to their engine displacement, the use the vehicle is designed for, serviceability, cost factors, and even visual appeal.

The material used for a frame is chosen by similar means. Generally, aluminum frames are reserved exclusively for sport type, on-road motorcycles, usually of middle to large engine displacement. Virtually all other frames are made of steel. Aluminum alloys are lighter than steel of the same strength, but are bulkier and more expensive to produce.

A wide variety of tubing and pressed steel shapes as well as castings and forgings are combined to form the optimal framework for a particular model.

Many of the earliest Honda models used primarily a round steel tube frame. Later models up to 305 cc used a frame made mostly or entirely of pressed steel plate.

Some of today's frames are made almost entirely of round steel tubing of various sizes and thicknesses. Others are made up mainly of square steel tubing. Most aluminum frame members are some form of rectangular tubing, though a few pieces are square. The highest stressed rectangular aluminum members are often relatively complex extrusions designed to fulfill a specific set of requirements. Most aluminum and steel frames include some castings or pressed steel sections in order to form strong and compact tube joints, and for pivot or major attachment points.

Round tubing has the same strength in all directions. Square and rectangular tubing (as well as other variants) have different strength characteristics in different directions. When the maximum strength is required in a vertical direction and the strength in a horizontal direction is not as important, rectangular tubing with greater strength in the areas needed is chosen. At times a frame is lightened by changing the combination of the types of tubing.

Thinwall rectangular aluminum tubing is strengthened by internal stiffening ribs and extrusion production. Some models use a special modified pentagonal or hexagonal extruded aluminum tubing (with internal strengthening ribs) in order to improve the frame member's strength to weight ratio, its rigidity in one or more specific directions, and in some cases, to allow a more compact and unobstructed riding position.

The various material types, forms and dimensions used in frame design are linked directly to the experience gained from Honda's ongoing racing programs around the globe. As new knowledge is gained through competition, it is combined with input from non-competition testing and utilized in the construction of each new generation of production machine.

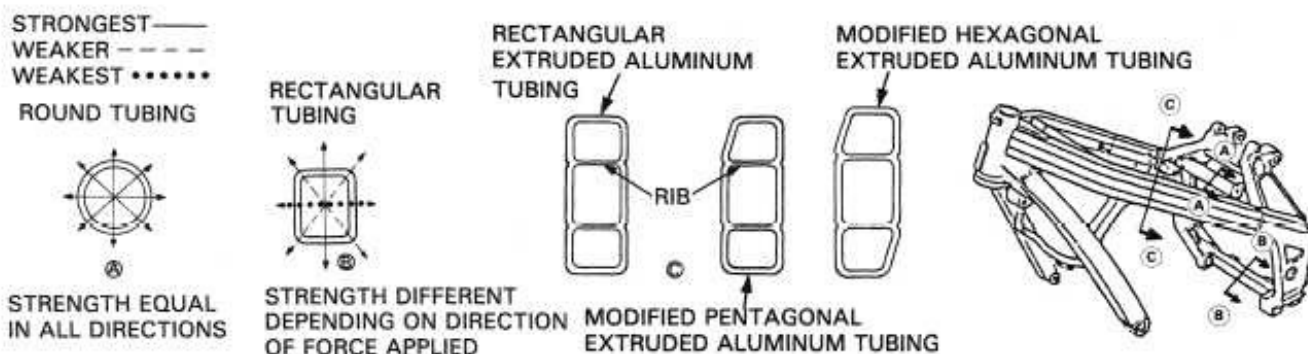

The frame also serves to absorb vibration from the engine and, to some degree, from the road surface. The difference in basic frame structure is determined according to the engine type and the type of use the machine is designed for.

Two only slightly different frame designs may have significantly different vibration absorbing or generating characteristics which make one design correct and the other unsuitable, even with the same engine installed. Therefore, the particular frame structure a machine ends up with is chosen according to the engine type and by the specific use the machine is intended for, in order to prevent unpleasant vibration to the rider and premature fatigue to structural members.

Frames are classified as follows, according to differences in basic structure:

BACK-BONE

This type of frame is made up of a combination of pressed steel plate and steel tubing.

This basic frame design is used mainly on scooters and some of Honda's early motorcycle designs. Back-bone construction allows added freedom in the overall design of the vehicle and relatively economical production.

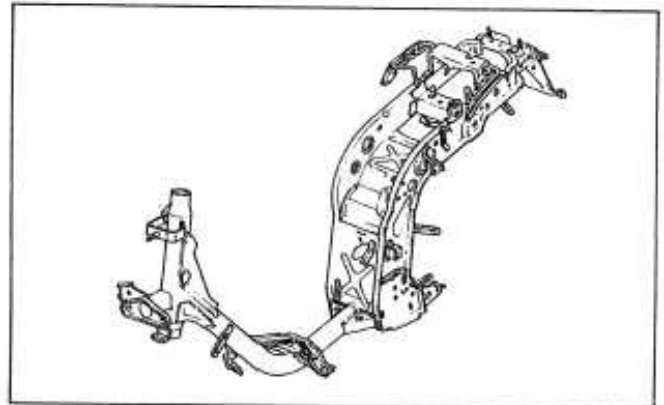

DIAMOND FRAME

With a diamond frame, lower section of down tube is not connected with other frame tubes. The engine forms the final portion of the frame structure and generates the frame strength. The diamond frame is used mainly on small and middle-size vehicles due to the simplicity of its structure and its light weight and excellent serviceability.

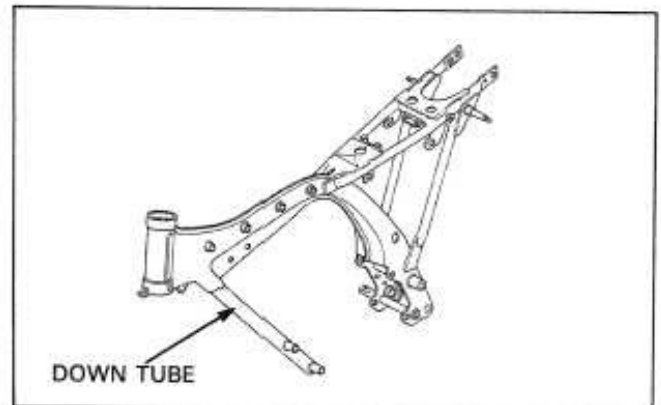

SINGLE CRADLE FRAME

The single cradle frame has one down tube and one main pipe at the front of the engine. The frame structural material surrounds the engine. This frame is mainly applied to off-road vehicles and middle-sized, street sport models due to its light weight, durability and ease of serviceability.

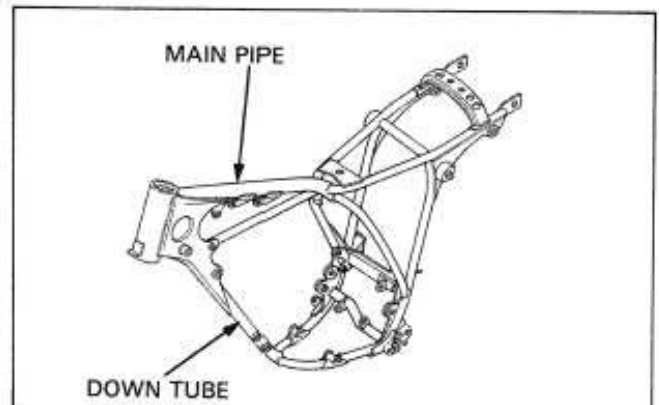

DOUBLE CRADLE FRAME

The double cradle design is similar to the single cradle frame, but has two down and main tubes, resulting in increased rigidity. A part of the down tube can be removed to facilitate engine removal on some models. This frame is mainly used on large displacement street motorcycles.

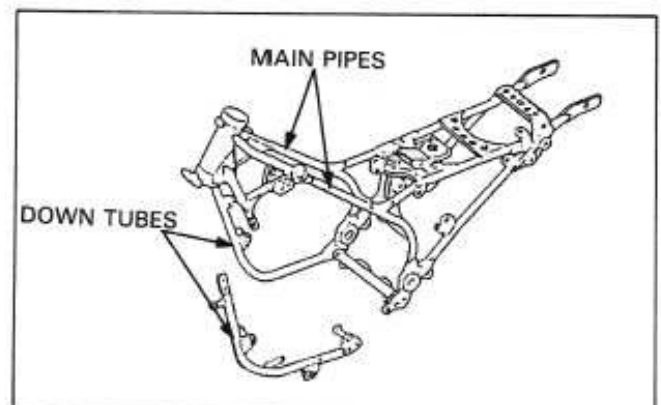

FRAME/BODY PANELS

SUB FRAMES

The sub frame can be removed to improve the service access on some models. This frame is mainly used on sport type motorcycles.

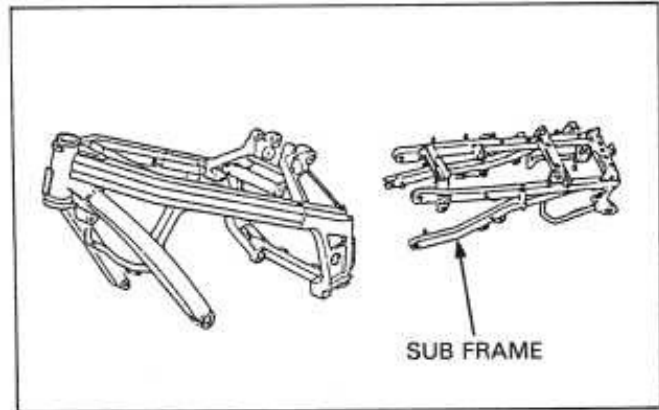

INSPECTION

Visually check the frame for damage or bent tubes and components.

Straighten the handlebar and check the alignment between the front and rear wheels.

If the rear wheel does not align with the front, check that the drive chain adjusters are adjusted correctly.

If the rear wheel leans to either side when viewed from above, check whether the right or left arm is twisted or bent. Take a horizontal view of arm section of the swingarm. Check the alignment of the rear shock mounts (on dual shock models) in the same way.

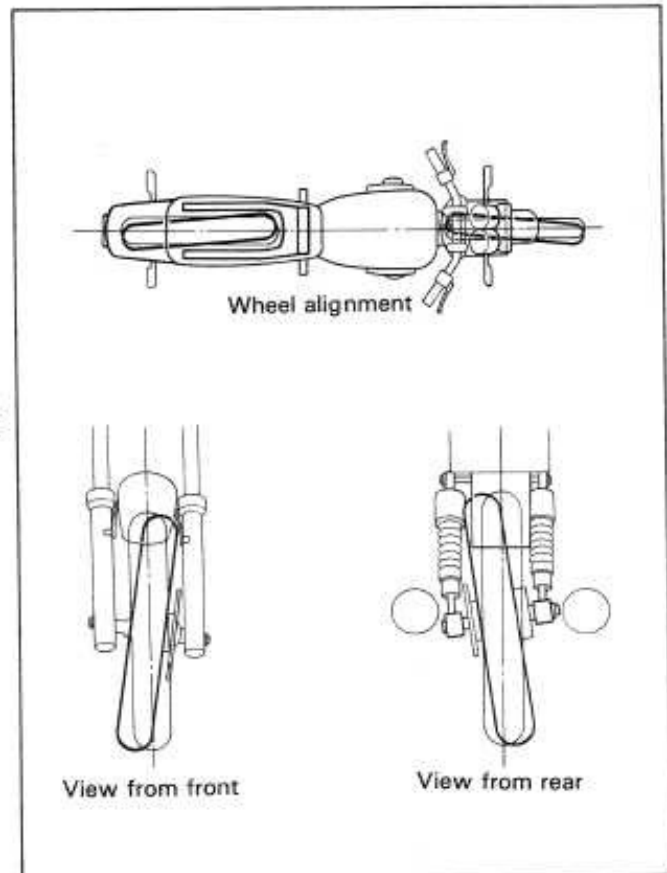

Apply penetrant to inspect the cracks.

NOTE

- Refer to penetrant manufacturer's instruction manual for the proper product use and inspection procedures.

If cracks appear in the paint on the frame, inspect the area(s) more closely to find out if the frame material itself is cracked.

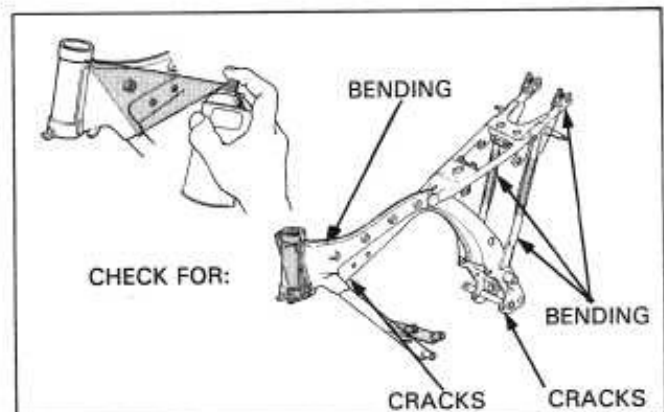

21. ELECTRICAL FUNDAMENTALS

SERVICE INFORMATION	21-1	BASIC ELECTRICAL DIAGNOSTIC METHODS	21-14
BASIC ELECTRONIC KNOWLEDGE	21-6		
ELECTRICAL SYMBOLS	21-13		

This chapter illustrates the safety precautions and the basic knowledge required for servicing electrical systems. Other chapters related to electrical systems do not contain the basic information presented in this chapter. Read this chapter thoroughly in order to understand the basic safety procedures and diagnostic methods before starting any service.

SERVICE INFORMATION

- When connecting harnesses, connect wires only with wires of the same color. In the few instances when wires with different colors are connected, there is always a colored tube near the terminal (see the illustration below).
- Connect connectors with the same colored connectors.
- For striped wires, the stripe color is indicated after the color of the wire in Honda service manuals.

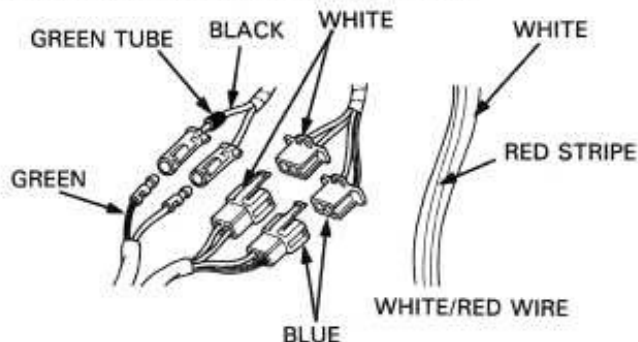

- Disconnect the negative cable of the battery before working on any electrical component.
- Do not let the tool contact the frame when disconnecting the cable.

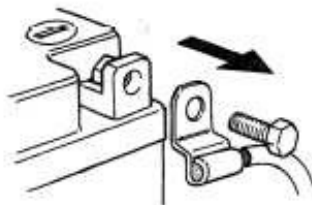

- When measuring voltage/resistance of wire terminals using a tester, insert the probes from behind the connector. For water-proof connectors, insert the probes from the front to avoid opening the wire terminal.

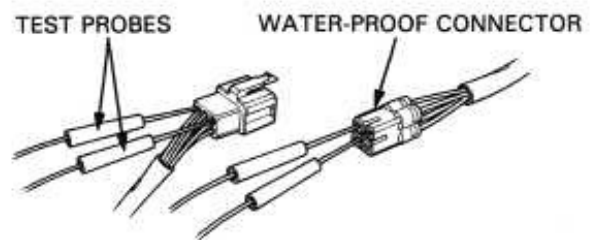

- Connect the positive terminal first when connecting a battery.
- Coat the terminals with clean grease after connection. Make sure the protective cover is secured on the terminal.



- After completing a job, check that all terminal protectors are placed correctly.



21

ELECTRICAL FUNDAMENTALS

If a fuse blows out, diagnose the cause and repair it. Replace the fuse with one of the correct rating.

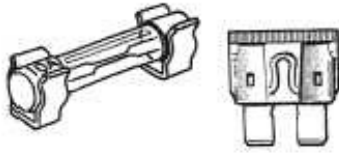

Always separate wire connectors with the ignition switch in the OFF position.

Before separating a connector, check whether its locking mechanism is of the push-in type or pull-up type.

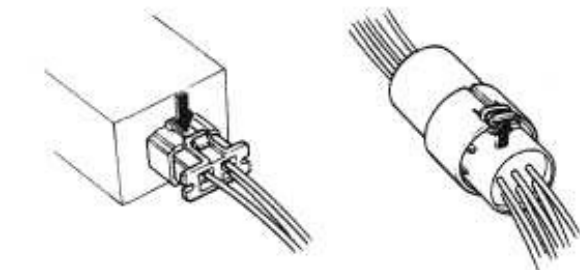
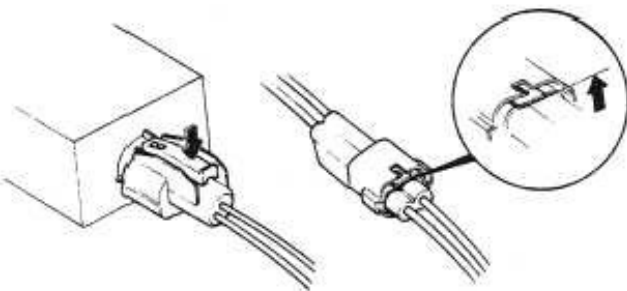
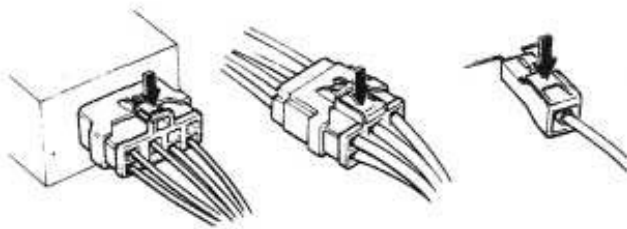

When separating connectors, pull only on the connector housing. Do not pull on the wires.

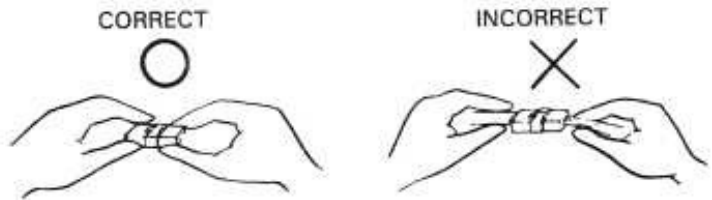

Make sure protectors completely cover the connectors and terminal.

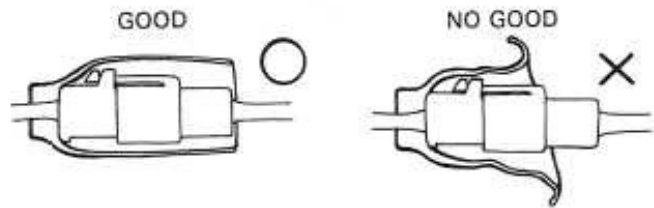

When installing a connector, push it until it clicks into place. For connectors with locks, push the connector in lightly then unlock the lock. Check that the lock is securely fastened when reconnected.



Make sure that the harnesses are secured to the motorcycle properly. Before connecting connectors, check that the pins are straight and that all the wire terminals are intact and tight. If a terminal is corroded, clean it thoroughly before connecting.

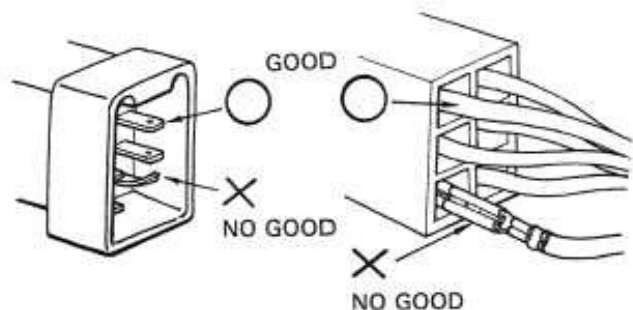

- Check for torn protective covers and oversized, loose fitting, female terminals before installation.

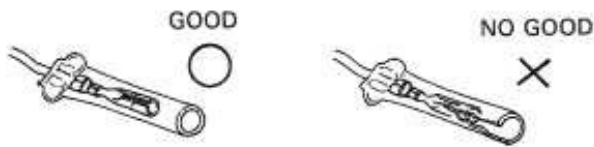

- Replace damaged wires with new ones.

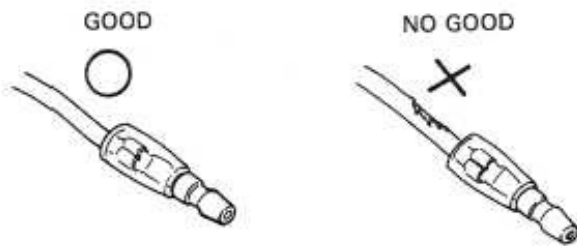

- Secure wires and wire harnesses to the frame with wire bands at the designated locations. Install the bands so that only the insulated surfaces contact the wires or wire harnesses.

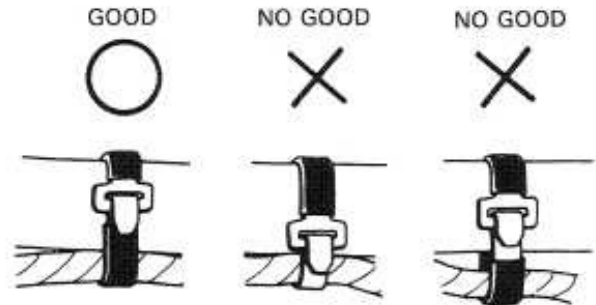

- Do not squeeze a wire against a weld or the end of its clamps.

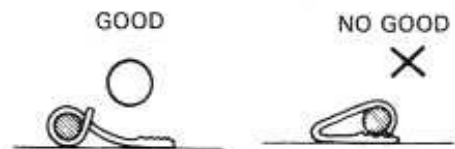

- Connectors with protectors facing up must have a drain hole.

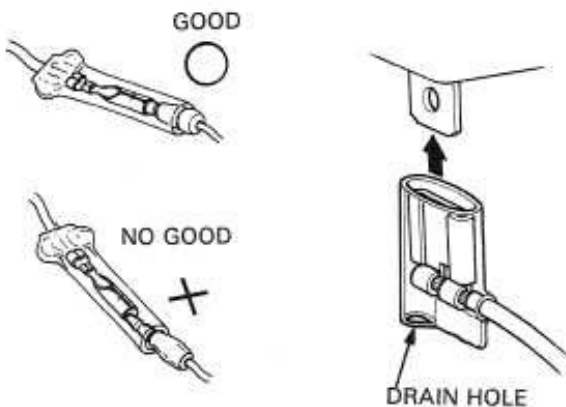

- Check that harnesses cannot come in contact with hot parts after clamping.



- Protect wires and harnesses with at least two layers of electrical tape or with electrical harness tubes if they contact a sharp edge or corner.

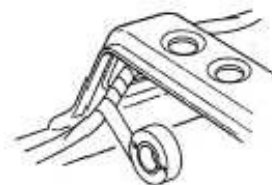

ELECTRICAL FUNDAMENTALS

- Check that the wire harness is securely clamped at all locations.

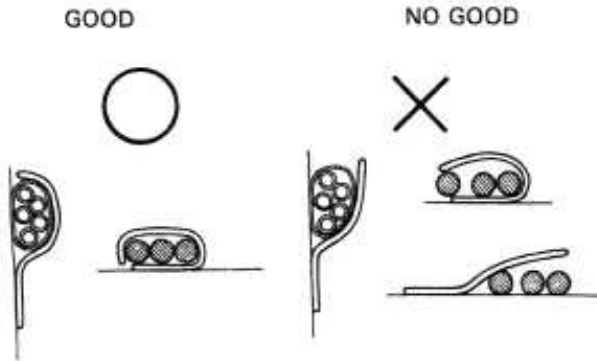

- Route wire harnesses to avoid sharp edges, corners or the projected ends of bolts and screws.

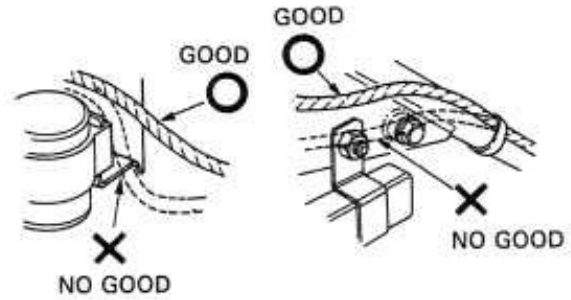

- To unlock a wire harness or hose from a clip, use a screwdriver to open up the tab. When locking the clip, press firmly until it clicks. If the clip was removed from the frame, replace it with a new one.

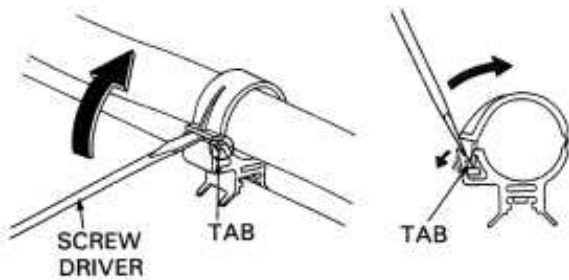

- Seat grommets in their holes properly.

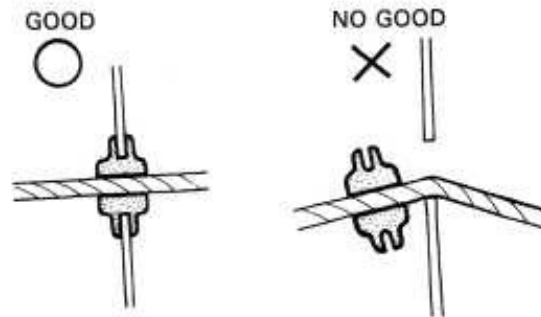

- Check that the wire harness does not interfere with any moving or sliding parts after clamping.

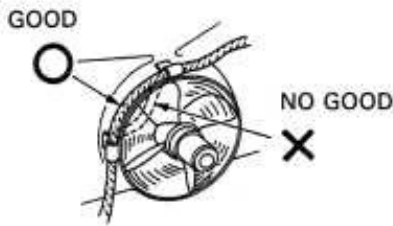

- Do not bend or twist wire harnesses.

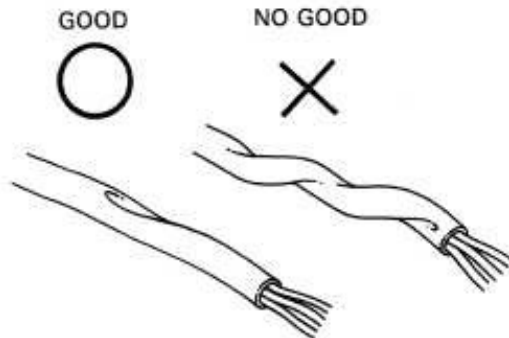

- Before using testers, read the instructions.

CAUTION

- Do not drop parts containing semiconductors. Semiconductors are fragile and sensitive to shock. Dropping a semiconductor could damage or destroy it.

- Be careful not to pinch or trap wires or harnesses under items during installation.

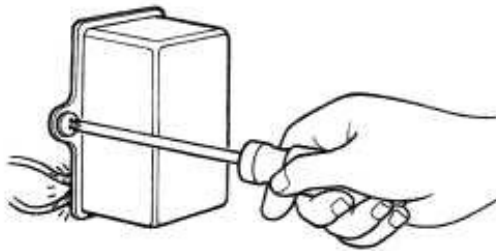

- Route wires and wire harness so that they are not too tight or loose when the handlebar is turned all the way to the right or left.
- Avoid routing wires and harnesses through sharp bends and around tight corners.
- Route harnesses so they are neither pulled taut nor have excessive slack.

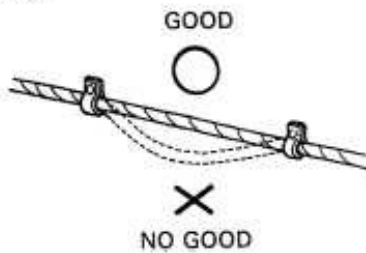

BASIC ELECTRONIC KNOWLEDGE

All matter, whether solid, liquid, or gas, is a collection of molecules, and each molecule is made up of atoms. Each atom consists of a nucleus (which is made up of protons and neutrons) and electrons, which circle around the nucleus.

Electricity flows when these electrons freely move outward from their orbits. Some materials become conductors when there are a lot of free electrons and some become insulators when there are no free electrons. It is a well known fact that when a piece of glass is rubbed with silk cloth, it generates "Static Electricity" attracting a piece of paper towards it. This happens because the free electrons in glass move into the silk due to the heat generated by rubbing. As a result, the glass takes on a positive charge and the silk cloth takes on a negative charge.

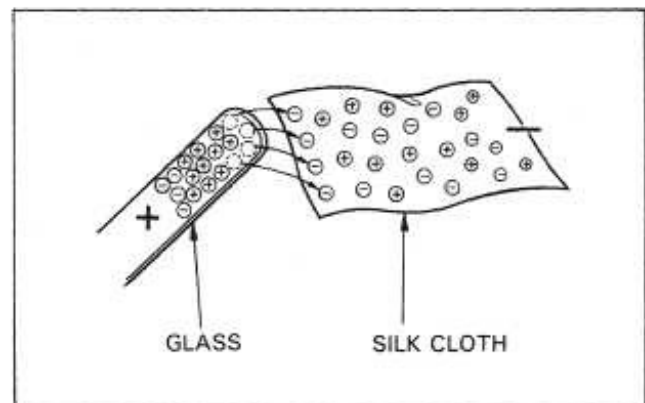
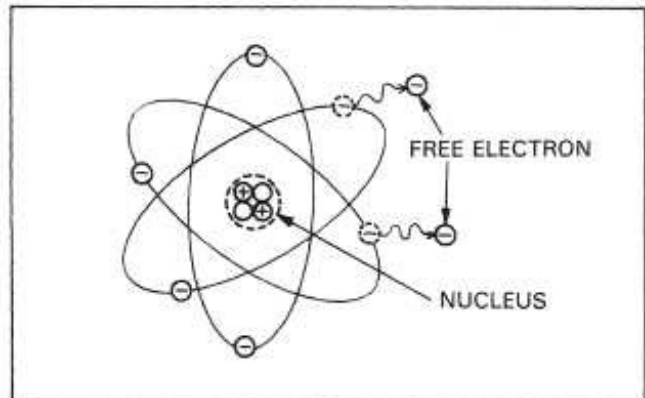

CURRENT FLOW

When a positive charged material and a negative charged material are connected with a conductor, free electrons flow from negative charged to positive charged material. This flow of electrons is called "electricity". For a long time it was thought that electrical current flowed from the positive side of the source to the negative side. When it was discovered that electrons actually flow the other way, it was too late to change existing publications on electricity. As a result, just for convenience, technical publications compromise by saying that electrical current flows from the positive to the negative side while electrons flow from the negative to the positive side.

It is convenient to think of the flow of electrical current as the flow of water.

The number of electrons passing any given point in a circuit in one second determines the current flowing through the circuit. The amount of current flow is measured in "Amperes (A)".

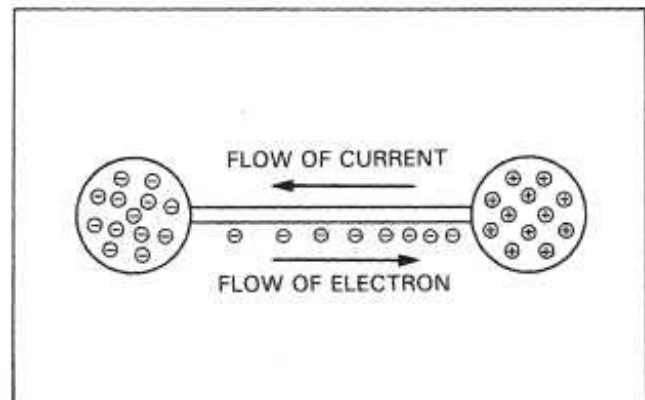

ALTERNATING CURRENT AND DIRECT CURRENT

All electrical components are supplied with either alternating current or direct current, abbreviated as AC or DC respectively.

The fundamental characteristics of the two currents differ completely, and for the purpose of servicing, you need to have a good understanding of these differences.

Alternating-current

Alternating current (AC) changes in voltage value and polarity with time. AC current flows in one direction until peak voltage is reached and then drops to zero volts. AC current then changes direction or polarity until peak voltage is achieved and again drops to zero and again changes polarity. From zero voltage to peak positive voltage to peak negative voltage and back again to zero voltage is known as a cycle.

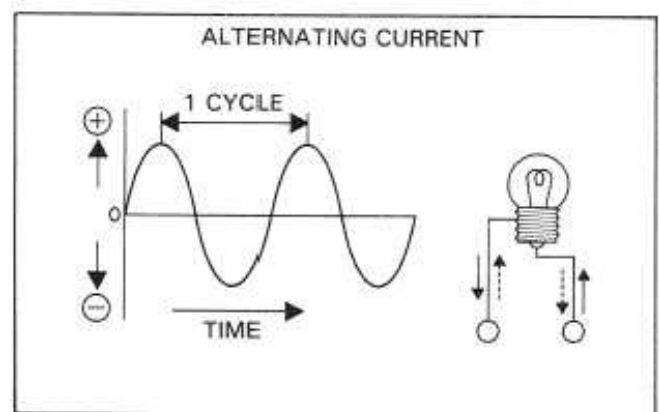

In motorcycles, all electricity generated is AC. However, AC can be converted to direct current (DC) by rectification. The DC current is then supplied to components operating on DC. For example, some models use DC for their headlights and others use AC.

For headlights operating on AC, the lights turn off when the current flow is zero, and then go back on again as the polarity becomes reversed. This ON-OFF cycle is repeated at a high frequency (number of cycles in one second) and is not noticeable.

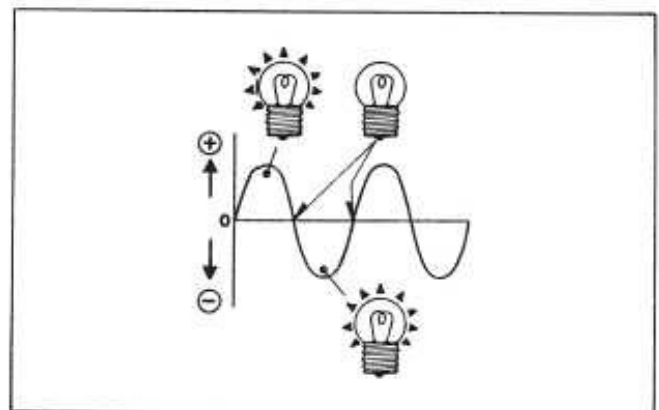

Direct current

Direct current is a current whose magnitude and direction remain constant. Its form is shown in the graph. Direct current is abbreviated as DC. Motorcycle batteries, and household batteries supply DC.

DC has the following characteristics as opposed to AC.

- DC can be stored in batteries and discharged when needed. (AC cannot be stored)
- DC is capable of a large current flow. (Good for starter motors)
- DC voltage cannot be stepped up or down. (AC voltage can be changed using a transformer)

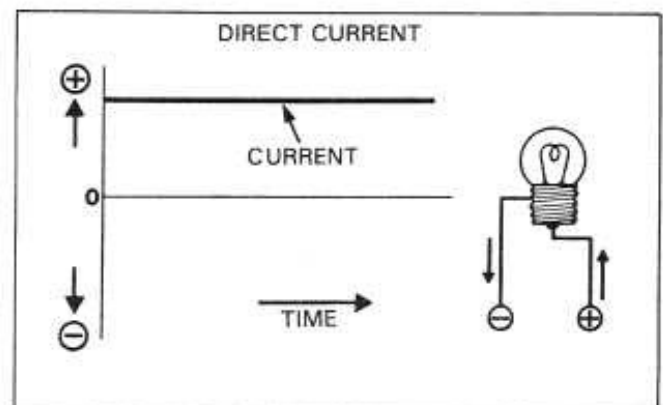

ELECTRICAL FUNDAMENTALS

VOLTAGE

As illustrated in the figure to the right, when two water tanks, A and B, are connected, water flows from tank A to tank B. This flow is the result of a pressure difference between the two tanks.

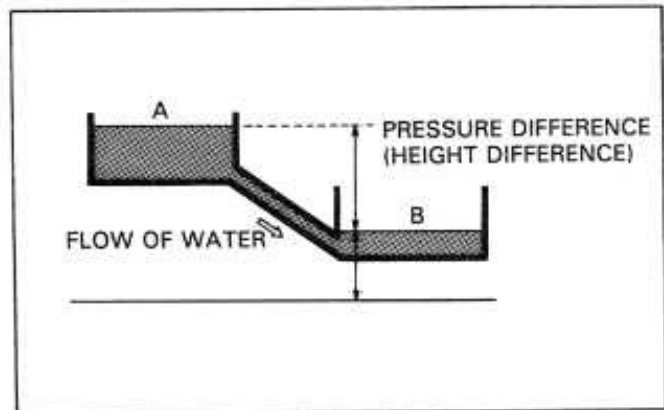

This same concept applies to electricity. The pressure difference, called the electrical potential difference, causes current to flow through a circuit. The pressure of the current is measured as voltage (V).

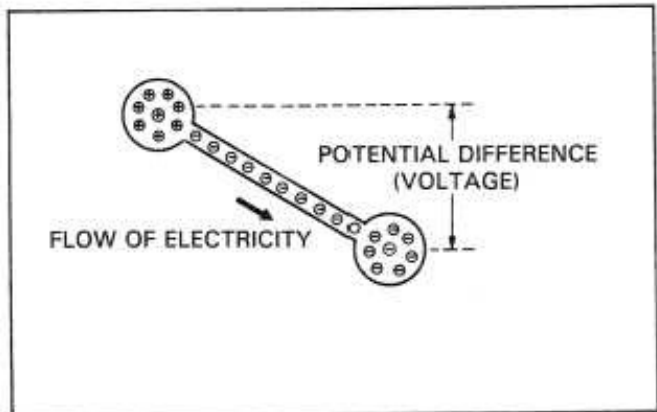

RESISTANCE

As everyone knows, water flows through a larger pipe easier than a smaller pipe. This is because the smaller pipe provides greater resistance. Similarly, electrical current flows through a thicker wire (conductor) more easily than a thinner wire. The resistance limiting the flow of electricity through a wire is measured in Ohms (Ω).

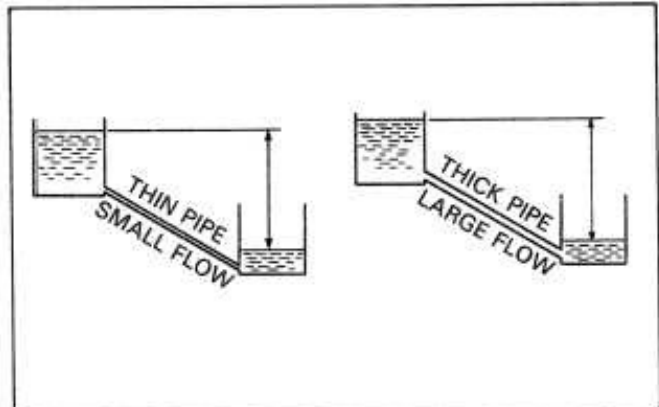

Resistance increases as the size of wire become smaller and longer. This resistance value can be measured with an ohm-meter.

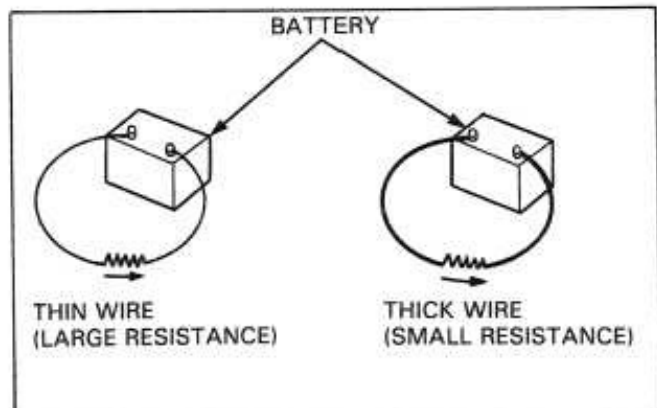

OHM'S LAW

The amount of current flowing through a conductor in a closed circuit is proportional to the voltage applied to the conductor. The relationship between voltage and current flow and resistance is known as Ohm's law.

For example, if a 6 Ω resistor is connected to the + and - terminals of a 12 V battery, the current flowing through the resistor can be calculated by Ohm's law:

$$\text{Current} = \text{Voltage} \div \text{Resistance} = 12 \div 6 = 2 \text{ A}$$

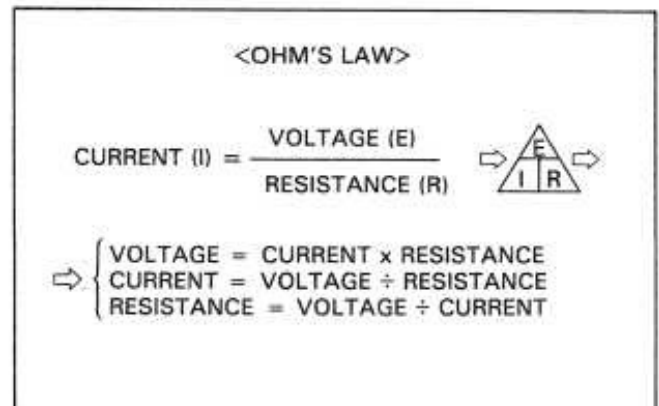

POWER

We use electricity to operate headlights or starter motors, or we convert it to heat. The amount of work required to do these things is measured in Watts. Changing voltage (Volts) or the rate of current flow (Amperes) increases or decreases electrical power output (Watts). The relationship is defined as:

$$W = E.I \text{ (Power = Voltage} \times \text{Current)}$$

ELECTRICAL CIRCUIT

As shown in the diagram at right, when a light bulb is connected to a battery, the current flows in the direction of the arrow and the light bulb turns on.

The path in which an electric current flows, is called a circuit. On Honda motorcycles, scooters and ATVs, the ground wire of an electrical circuit is connected to the engine or frame. Grounding the negative terminal is called a negative terminal ground type.

All Honda motorcycles, scooters and ATVs share the negative ground circuit shown in the diagram.

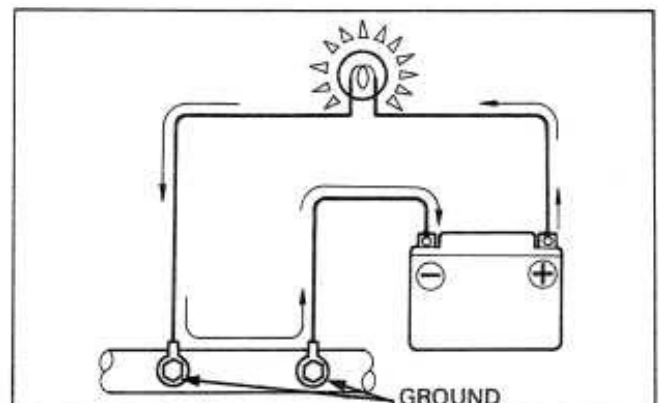

ELECTRICAL FUNDAMENTALS

Series Circuit

A series circuit is an electric circuit in which the current flows through one device into another, and then to ground. There is only one current path and the voltage is distributed by the loads. The total resistance (Ω) can be found by simply adding all the resistances, eg: $R = R1 + R2$

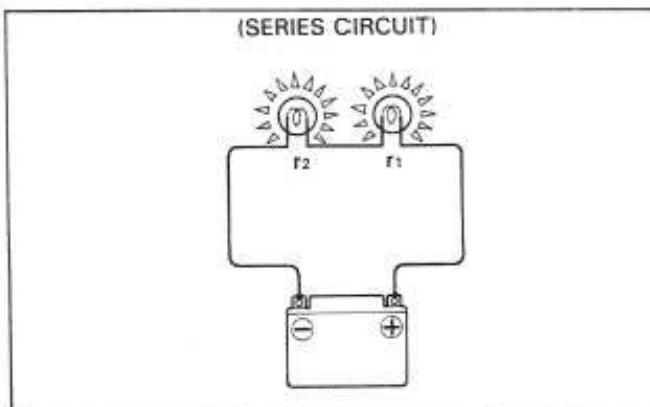

Parallel Circuit

A parallel circuit is an electric circuit which has two current paths, one for the positive and one for negative. The devices are connected across the two paths. The voltage on each load is the same, but the current branches out to each load. The current flow to each load can be calculated as $i_1 = E \div r_1$, $i_2 = E \div r_2$.

The total current (I) is the sum of all current flowing to each load.

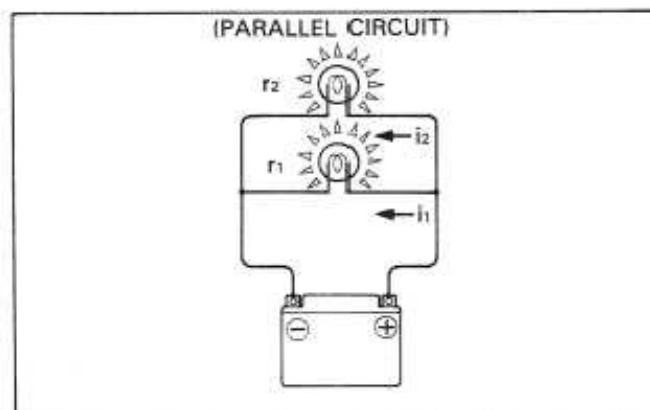

SEMICONDUCTOR

The electrical conductivity of semiconductors lies between that of conductors and insulators. Before understanding how they work in circuits, you need to have a basic knowledge of their characteristics.

Diode

The diode allows current to flow in only one direction. When current is flowing, there is a slight voltage drop across the diode.

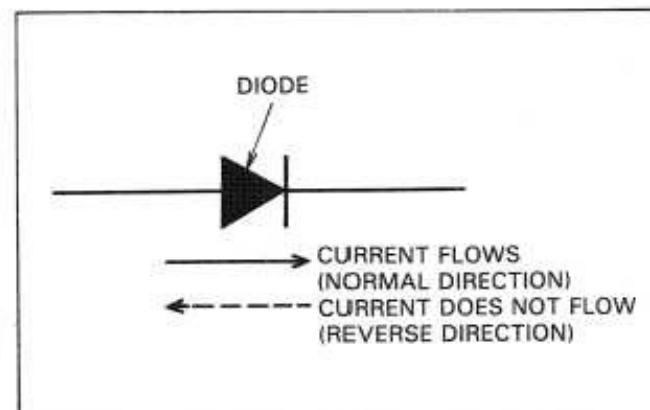

Zener Diode

The zener diode allows current to flow in one direction similar to the diode above. When a certain reverse voltage is applied, current abruptly flows in the reverse direction. When the voltage is reduced below the reverse voltage, current flow in the reverse direction stops.

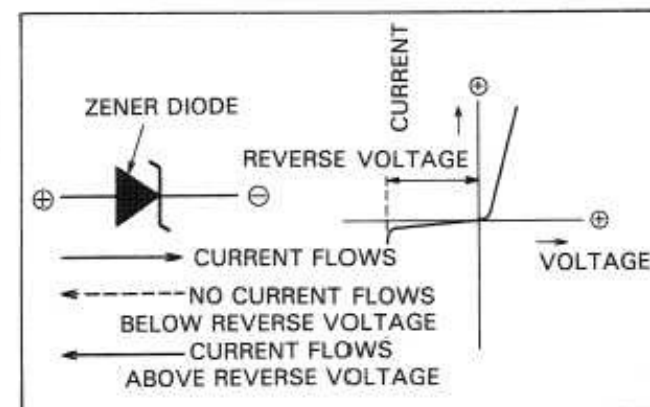

Thyristor (SCR)

Thyristors have three terminals: anode, cathode, and gate. The current flowing from the anode to cathode is said to be in the positive direction.

Like diodes, thyristors do not allow current to flow in the negative direction. When turned on, thyristors allow current to flow from anode to cathode only.

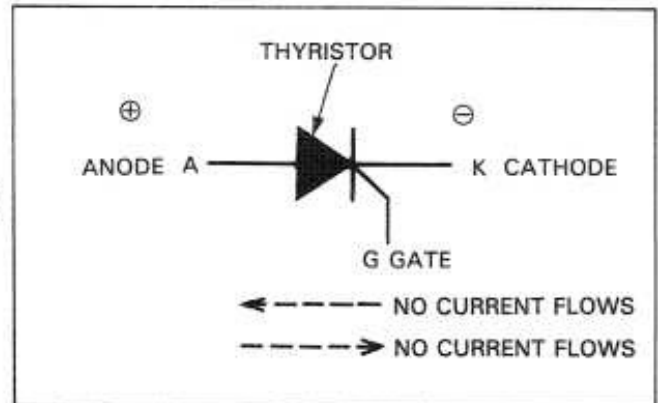

The thyristor is turned on when a certain amount of voltage is applied to the gate. This input to the gate is called gate voltage or trigger voltage.

Once the thyristor is turned on, there is no need to continuously apply voltage to the gate, and its characteristics become identical to a regular diode.

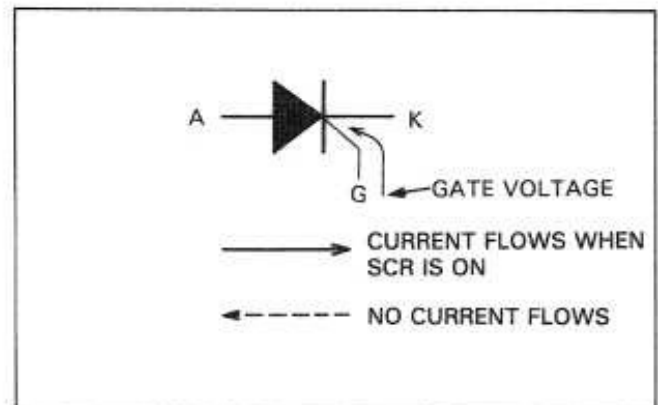

Transistor

A transistor has three terminals; emitter (E), collector (C), and base (B).

There are two types of transistors: PNP and NPN type.

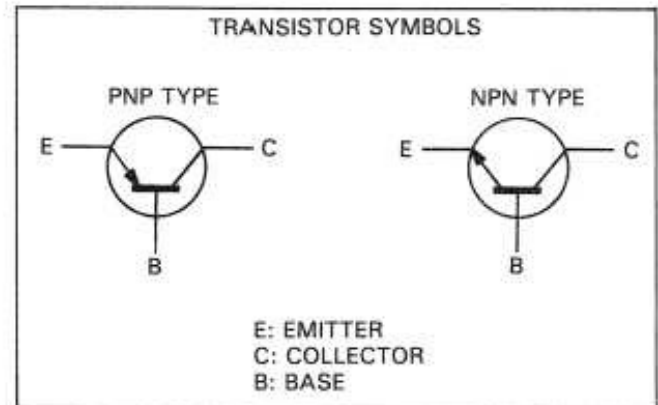

In PNP type transistors, when a positive voltage is applied to the emitter and negative voltage to the collector, almost no current flows from the collector to the emitter. If the emitter voltage is raised slightly higher than the base voltage and a small amount of current flows from the emitter to the base, a large amount of current flows from the emitter to the collector.

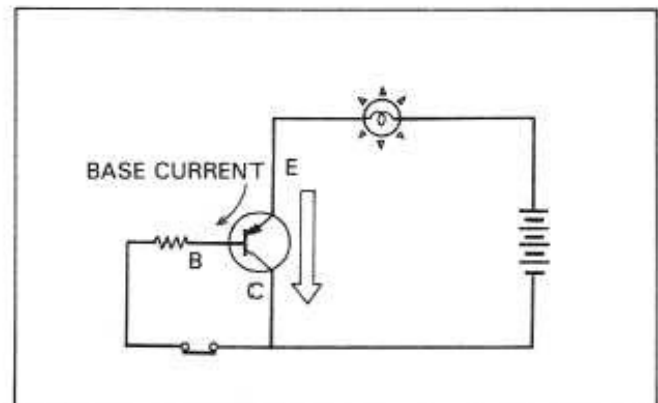

ELECTRICAL FUNDAMENTALS

In the NPN type, almost no current flows when a positive voltage is applied to the collector and a negative voltage to the emitter. When a small current flows from the base to the emitter, a large current flows from the collector to the emitter.

In this way, the transistor resembles an amplifier in that the amount of collector to emitter current is controlled by the base current.

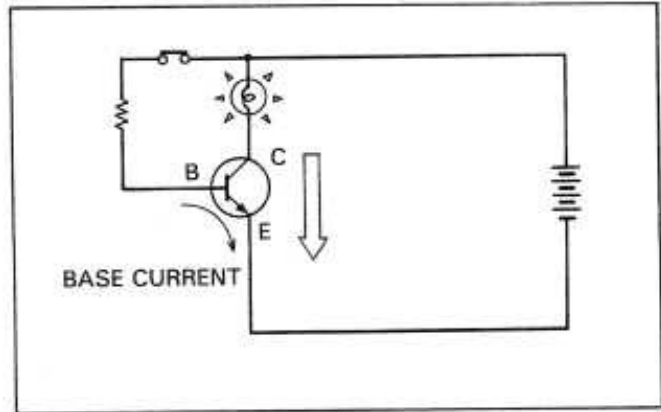

Transistors also resemble switching devices. The transistor is turned on, allowing collector-to-emitter current to flow, when there is base current, and turned off when no base current exists.

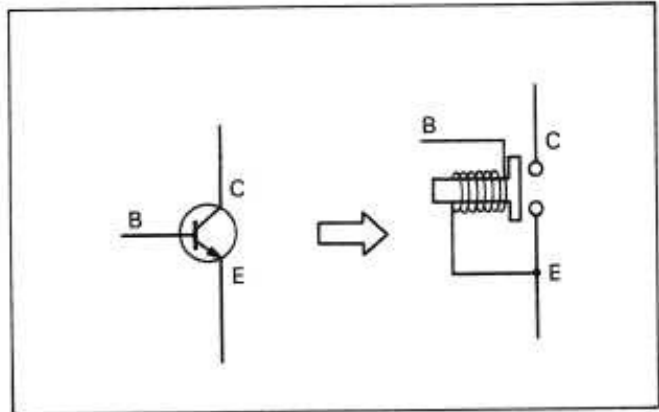

Thermistor

In general, the resistance value of most metals, including copper, increases as the temperature rises. When heat is applied to a substance, the activity of its molecules increases and prohibits the flow of free electrons. This increases the resistance.

In contrast, the resistance of a thermistor decreases as the temperature rises.

This is because the number of free electrons increases as heat is applied to the thermistor. In this case, the activity of the molecules no longer obstructs the flow of electrons and the resistance decreases.

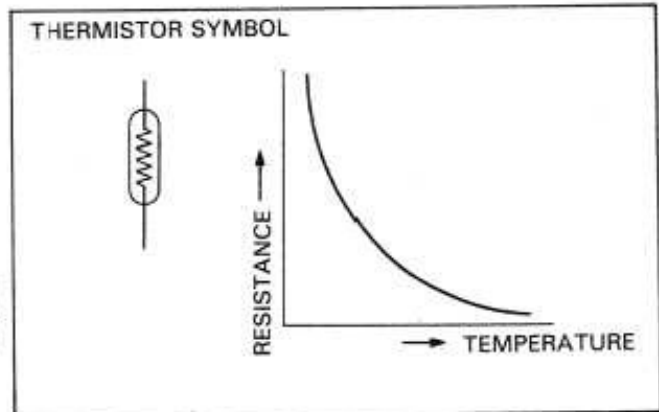

ELECTRICAL SYMBOLS

The symbols below are the most common type of symbols used in electrical circuits.

Abbreviations used in switching devices are as follows:
 NO (Normally Open): Switch is open at rest
 NC (Normally Closed): Switch is closed at rest.

BATTERY	CONNECTION		MULTI-TESTER			MOTOR
	Connected	No connection	Voltmeter	Ohmmeter	Ammeter	
PUMP 	CONNECTOR P = # of pin COLOR 	CONNECTOR (Round type) 	CONNECTOR (Flat type) 	EYELET TERMINAL 		
IGNITION SWITCH (Circuit symbol) 	IGNITION SWITCH (Wiring symbol) 	SWITCH (Two terminal) 	SWITCH (Three terminal type) 	SWITCH (Combination type) 		
FUSE 	RELAY (NO type) 	RELAY (NC type) 	LIGHT BULB 	GROUND 		
THREE PHASE ALTERNATOR 	SINGLE PHASE ALTERNATOR 	PULSE GENERATOR 	IGNITION COIL (Single type) 	IGNITION COIL (Dual type) 		
SPARK PLUG 	RESISTOR 	VARIABLE RESISTOR 	COIL 	SOLENOID 	LED 	CAPACITOR

BASIC ELECTRICAL DIAGNOSTIC METHODS

VOLTAGE MEASUREMENT

Measuring voltage is a fundamental method of checking circuit components. The measurement is conducted for the following reasons.

- ① To check if voltage exists. (A test light may also be used.)
- ② To measure the actual value.

A voltmeter is used to determine if an electrical component is operating normally.

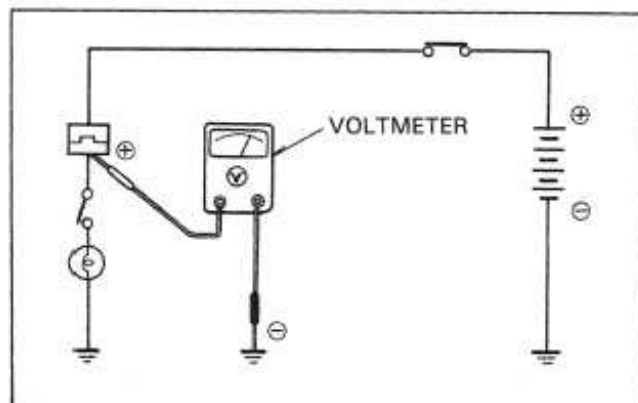

HOW TO MEASURE VOLTAGE USING A VOLTMETER

NOTE

- Make sure the ground surface is clean and free of paint. Use a bolt attached directly to the frame.

Select the current range to measure the expected voltage value. If the voltage value is unknown, start at the highest scale on the meter and go to lower scales as necessary to obtain an accurate reading. Apply the red probe to the positive end and the black probe to the negative end of the circuit. The diagram on the right shows that the voltmeter registers the voltage across the light bulb. Voltmeters are always connected in parallel, not in series.

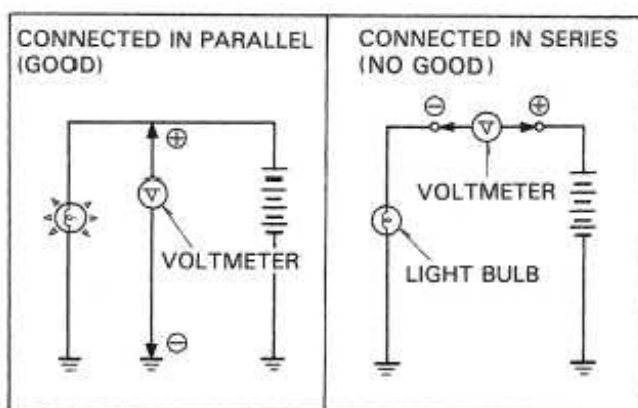

Example 1

First study the circuit diagram.

If light bulbs B and C do not work, and A is OK, check for voltage at bulbs B and C. If there is voltage, the problem is in the ground side of the circuit. If no voltage is found, the problem is on the "hot" side of the circuit.

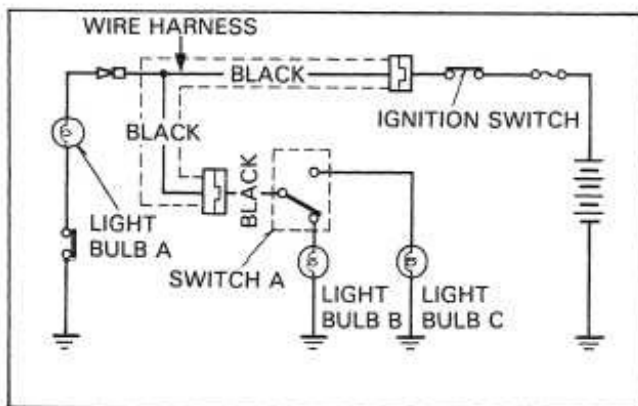

1. If both light bulbs B and C not working and there is no voltage at bulb B and C with the ignition switch ON, check voltage at ①.
2. If no voltage is measured at ①, check voltage at ② in case of a bad connection at connector A. If voltage exists at ② and not at ①, there is problem at connector A.

If voltage registers at both ① and ②, switch A should be checked.

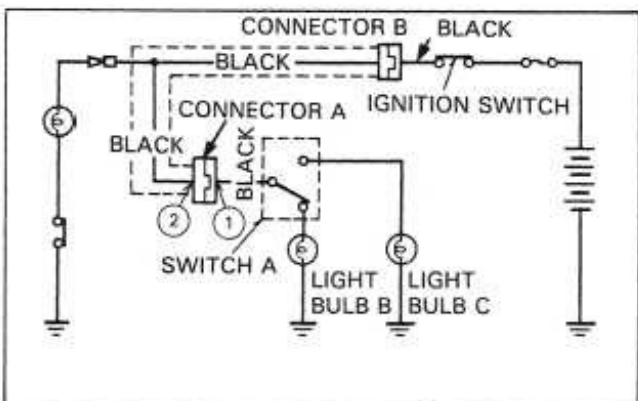

3. If there is no voltage at ① and ②, check voltage at ③ and ④ in a similar manner.
- If there is no voltage at ③ and ④, check wiring between the ignition switch and the battery.
 - If there is voltage at ③ and ④, check for a broken wire or a short circuit in the wire harness. Replace the wire harness with a new one if necessary.
 - If there is voltage at ④ and not at ③, then check connector B for looseness.

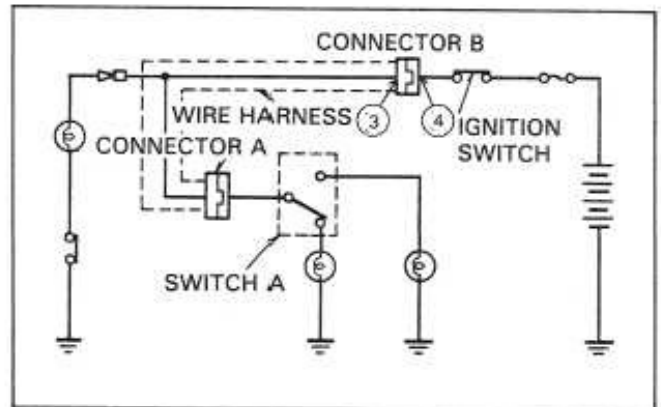

Example 2

Sometimes it is easier to diagnose a component by measuring voltage directly at the input terminals.

Please, the (+) probe voltage at the positive input terminal and the (-) probe at the ground wire of the component.

If no voltage is measured, there are three possible causes.

- ① Faulty battery: Check between the battery's positive wire and ground.
- ② Open circuit between battery and positive terminal: check for any intermediate circuits (i.e., switches).
- ③ Loose/shorted ground wire: Check for a secure grounding; check for continuity of the wire itself.

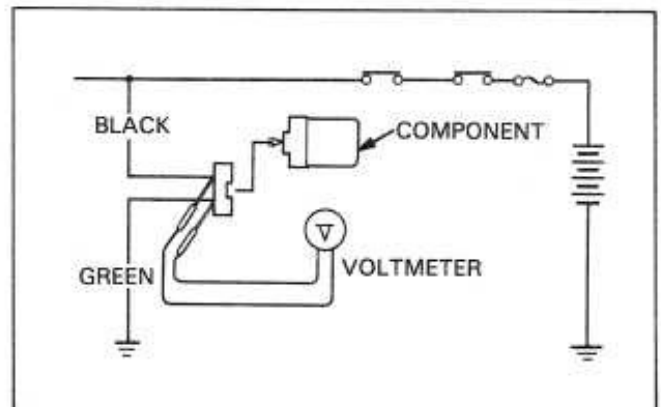

Example 3

For instance, if a light bulb blows out frequently, the system is working correctly.

For instance, if a light bulb blows out frequently, the system needs to be checked with an AC voltmeter to see if excessive voltage is apparent. In this case, measure the AC voltage of the terminals to the light bulb to see if it is within the specified voltage range.

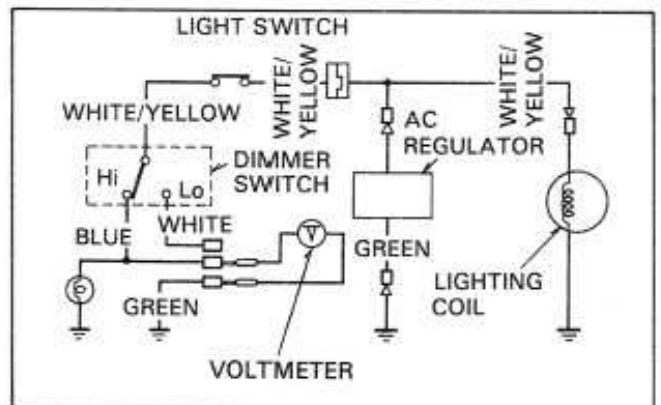

ELECTRICAL FUNDAMENTALS

MEASURING RESISTANCE

Along with voltage, resistance is another basic parameter for diagnosing circuits and their components.

Resistance is measured for the following reasons.

- ① To check if components are working properly:
The resistance value of a coil (eg. ignition coil) indicates if it is normal or malfunctioning.
- ② To check for a broken wire.
A continuity check indicates if a wire is intact or broken.

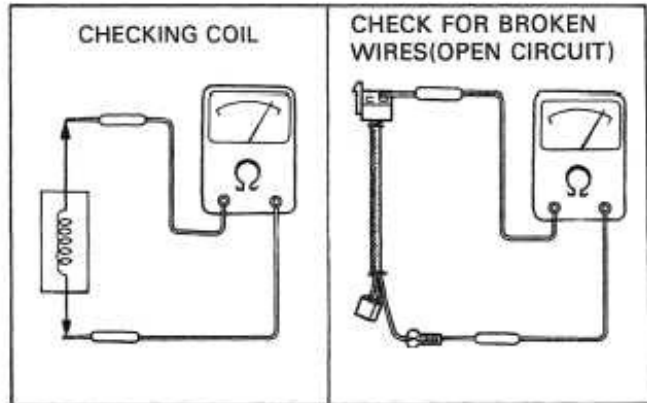

How to measure resistance using an ohmmeter

NOTE

- Proper zeroing of an analog ohmmeter is necessary to obtain correct measurements. Touch the two probes together and adjust the ohmmeter so that it registers 0 (Ω). For a digital ohmmeter, note the resistance when you touch the two leads together, and subtract this amount from your meter reading.

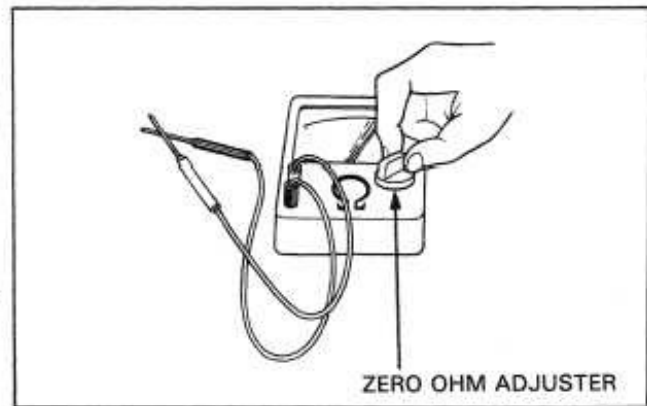

Since the polarity of the terminals is not important, either probe may be applied to either terminal. However, since diodes allow current to flow in one direction only, the polarity is important when checking diodes.

Unlike when measuring voltage, it is necessary to disconnect the component from the circuit. If resistance is measured with the entire circuit connected, the ohmmeter will read a different resistance than it should.

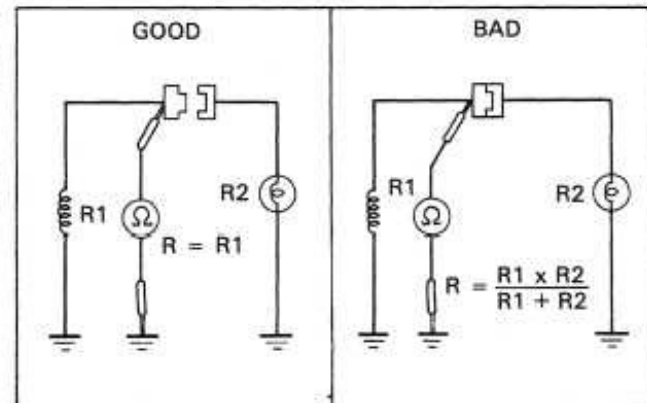

Similarly, if a circuit has branches the connector leading to the specific branch needs to be disconnected in order to read resistance correctly.

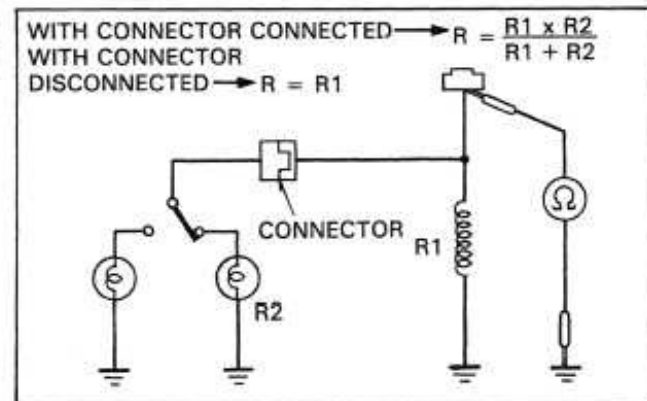

When the ohmmeter is connected in series, resistance values will be high.

In the diagram, measure resistance R1 by moving the probe shown at ① to ground.

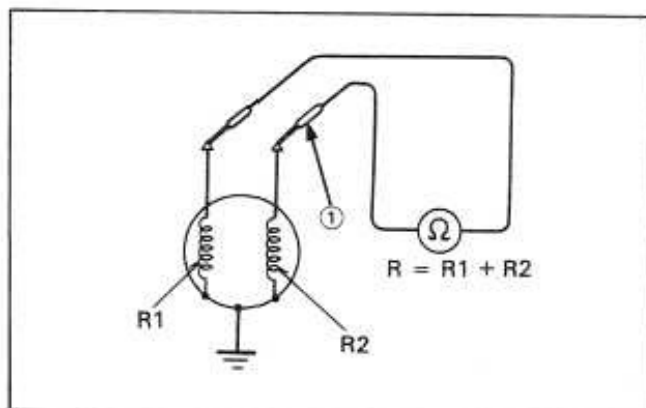

Example

To check the CDI exciter coil, resistance can be measured at ① or ②. Measuring resistance between ① and ground automatically checks for a broken wire (black/red) and for a bad connection at the alternator connector. If the resistance is normal between ① and ground, ② need not be checked.

If the resistance between ② and ground was checked first and the correct resistance was measured, there is still a possibility of a broken wire and/or loose connection between ① and ②. That would require more testing to locate the fault.

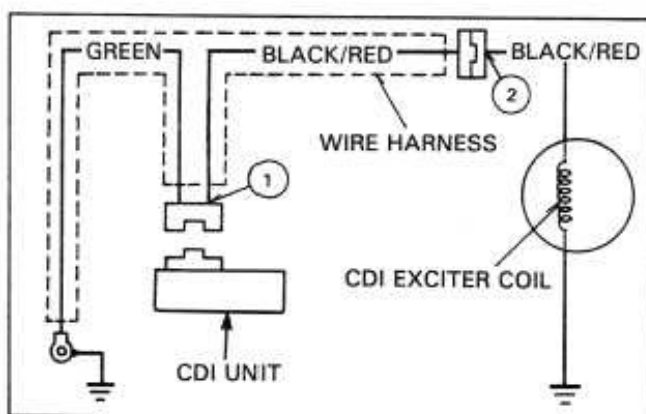

If, while measuring resistance at ①, the negative probe is placed on the ground wire (green), then the connection to ground is checked as well.

To check the operation of an exciter coil, place the probes as shown in the diagram. If the resistance is normal, then the exciter coil, the wire connected to the coil (black/red), and the ground wire (green) are all normal.

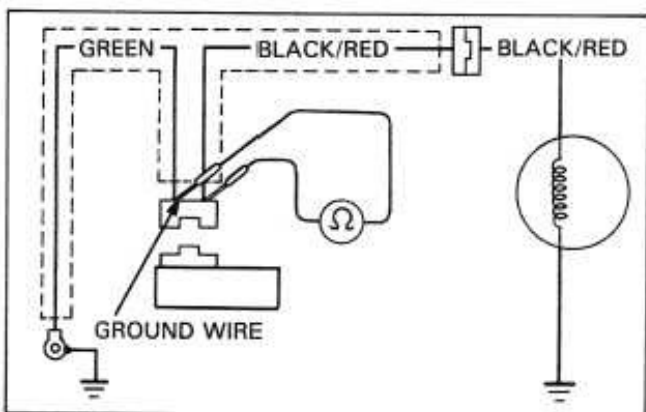

If the resistance is far off the standard value, check the following:

1. Broken ground wire (green)

Place a probe at ③ and measure resistance to ground. If 0 Ω is measured, then the green wire is properly grounded. If ∞ (infinity) is measured, then you may suspect a broken wire (green) or loose connection at the ground terminal.

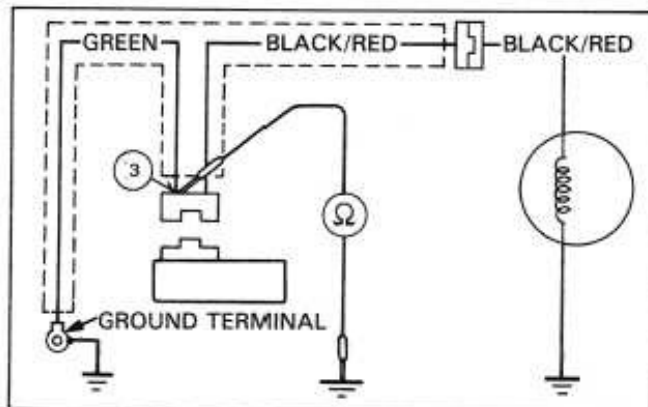

ELECTRICAL FUNDAMENTALS

2. Faulty exciter coil

Disconnect the alternator connector. Compare the resistance value at ② (measured on the previous page) and at ①.

- If the two values are not the same, suspect a broken black/red wire or loose alternator connector.
- If both resistance values are the same, but not in the correct range, the exciter coil may be faulty.

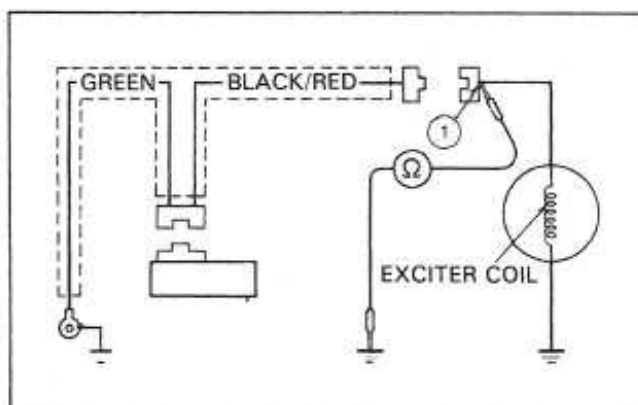

3. Shorted wire or wire harness

To see if the green or black/red wire is shorted, check the continuity between all other wires. If you have continuity between the other wires, replace the wire harness.

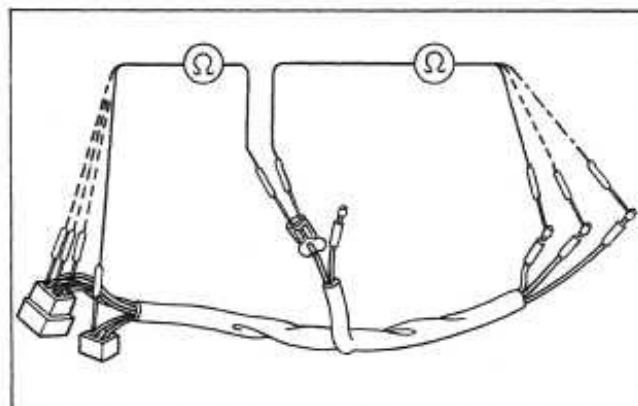

MEASURING CURRENT

Current is not normally checked during motorcycle service procedures. Though it is used for testing components, current measurements are not used for checking continuity within circuits.

How to measure current using ammeter.

Connect the ammeter in series in the circuit to measure the current flowing through it.

Touch the ⊕(red) probe to the positive end of the circuit and the ⊖ (black) probe to the negative end.

Make sure the current flow does not exceed the maximum range selected, or the meter could be damaged.

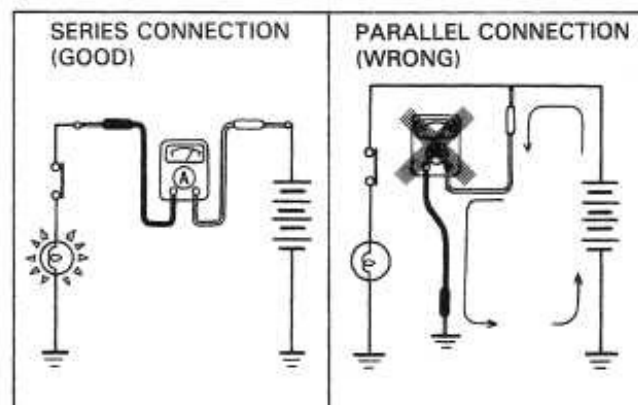

CAUTION

- Connecting the ammeter in parallel, like a voltmeter, can damage the ammeter from a current overflow.
- Connecting the ammeter between the battery terminals will damage the ammeter.
- Turning on the starter motor while the ammeter is connected between the battery terminal and the battery cable will damage the ammeter.

22. BATTERY/CHARGING/LIGHTING SYSTEM

SERVICE INFORMATION	22-1	CHARGING SYSTEM DESCRIPTIONS	22-14
TROUBLESHOOTING	22-3	CHARGING SYSTEM INSPECTION	22-21
BATTERY DESCRIPTIONS	22-6	REGULATOR/RECTIFIER INSPECTION	22-22
BATTERY REMOVAL/INSTALLATION	22-10	HEADLIGHT VOLTAGE INSPECTION	22-24
BATTERY TESTING/CHARGING	22-11	ALTERNATOR	22-27

SERVICE INFORMATION

⚠ WARNING

- The battery gives off explosive gases; keep sparks, flames, and cigarettes away. Provide adequate ventilation when charging or using batteries in an enclosed space.
- The battery contains sulfuric acid (electrolyte). Contact with skin or eyes may cause severe burns. Wear protective clothing and a face shield.
 - If electrolyte gets on your skin, flush with water.
 - If electrolyte gets in your eyes, flush with water for at least 15 minutes and call a physician immediately.
- Electrolyte is poisonous. If swallowed, drink large quantities of water or milk and follow with milk of magnesia or vegetable oil and call a physician.
- KEEP OUT OF REACH OF CHILDREN.

Always turn off the ignition switch before disconnecting any electrical component.

CAUTION

- Some electrical components may be damaged if terminals or connectors are connected or disconnected while the ignition is ON and current is present.

For extended storage, remove the battery, give it a full charge, and store it in a cool, dry place.

For a battery remaining in a stored motorcycle, disconnect the negative battery cable from the battery terminal.

Conventional Battery:

Use only distilled water in the battery.

CAUTION

- Tap water will shorten the service life of the battery.

Immediately wash off any spilled electrolyte using a mixture of baking soda and water.

CAUTION

- Avoid filling the battery above the UPPER LEVEL line to prevent an electrolyte overflow which could corrode the engine or nearby parts.

Maintenance Free Battery:

NOTE

- The maintenance free battery must be replaced when it reaches the end of its service life.

CAUTION

- The battery caps should not be removed. Attempting to remove the sealing caps from the cells may damage the battery.

- Refer to section 21 for basic electrical service and safety steps.
- Refer to section 2 for battery fluid and specific gravity.
- This section explains the basic steps for diagnosis and service. Refer to the Model Specific manual for the location of specific components.

BATTERIES/CHARGING/LIGHTING SYSTEM

- Batteries can be damaged if overcharged or undercharged, or if left to discharge for long periods. These same conditions contribute to shortening the "life span" of the battery. Even under normal use, the performance of batteries deteriorates after 2 – 3 years.
- Battery voltage may recover after battery charging. However, if the battery is subjected to a heavier load than it is designed for, the battery voltage will drop quickly and eventually die out (even if the charging system is working properly).
- A battery overcharge symptom may be caused by a shorted battery cell. If one of the battery cells is shorted, battery voltage will not increase to the specified level. Under these conditions, the regulator allows the alternator to supply excess voltage to the battery and the electrolyte level will drop quickly.
- Before troubleshooting the charging system, check for proper use and maintenance of the battery. Check if the battery is frequently under heavy load, such as having the headlight and taillight ON for long periods of time without the engine running.
- The battery will self-discharge if allowed to stand idle for a long time. For this reason, charge the battery every two weeks to prevent sulfation from forming when the vehicle is not in use.
- Filling a new battery with electrolyte will produce some voltage, but will not allow the battery to achieve its maximum performance. Therefore, you should always charge a new battery. Battery life is lengthened when a new battery is charged before installation.
- When checking the charging system, always follow the steps in the troubleshooting flow chart.
- Question the customer to determine how his riding habits affect battery charging:
 - High rpm riding may overcharge the battery (on motorcycles without a regulator).
 - Low rpm riding with frequent brake/brake light usage may result in discharging the battery.

TROUBLESHOOTING

CHARGING SYSTEM

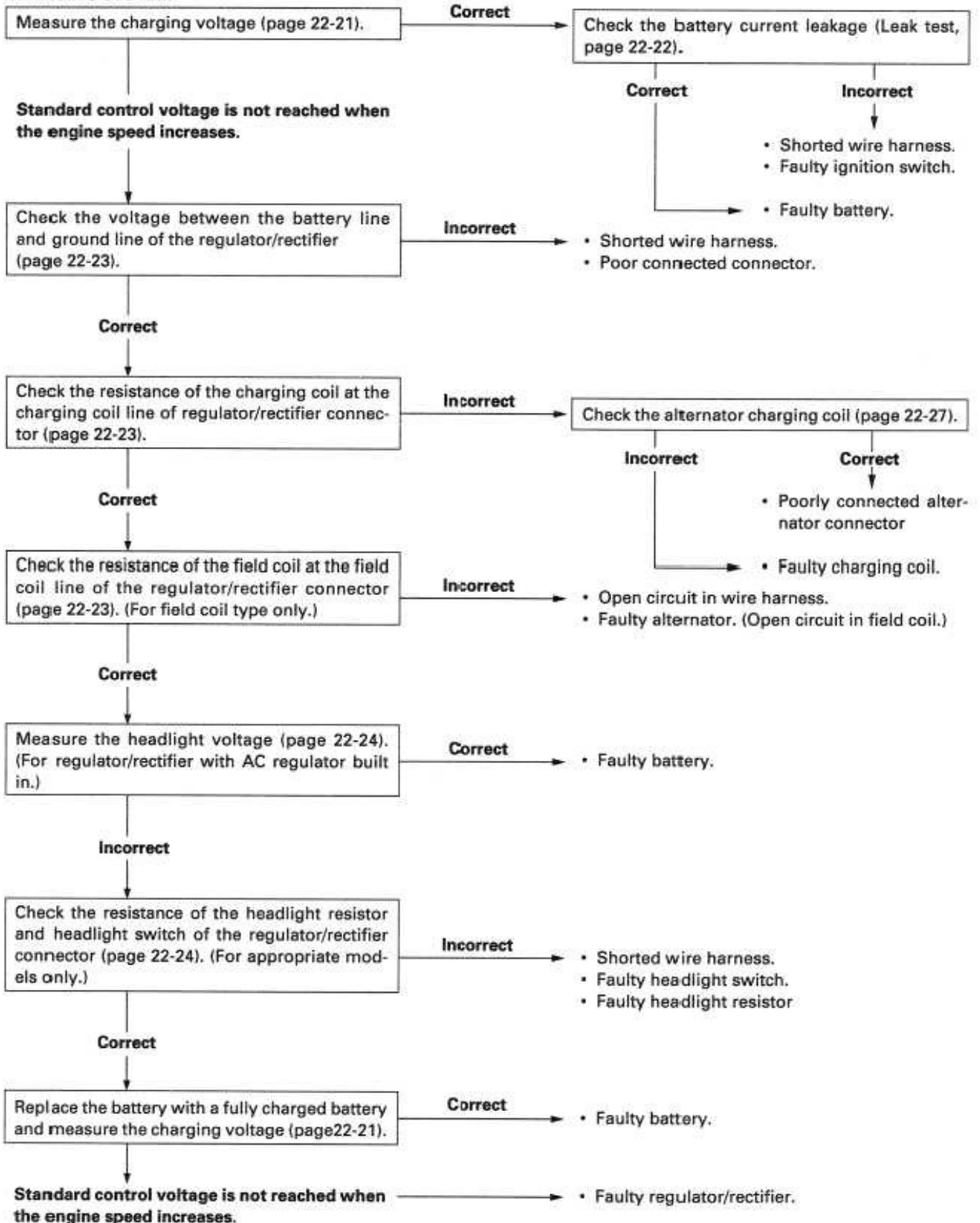

BATTERIES/CHARGING/LIGHTING SYSTEM

CHARGING SYSTEM

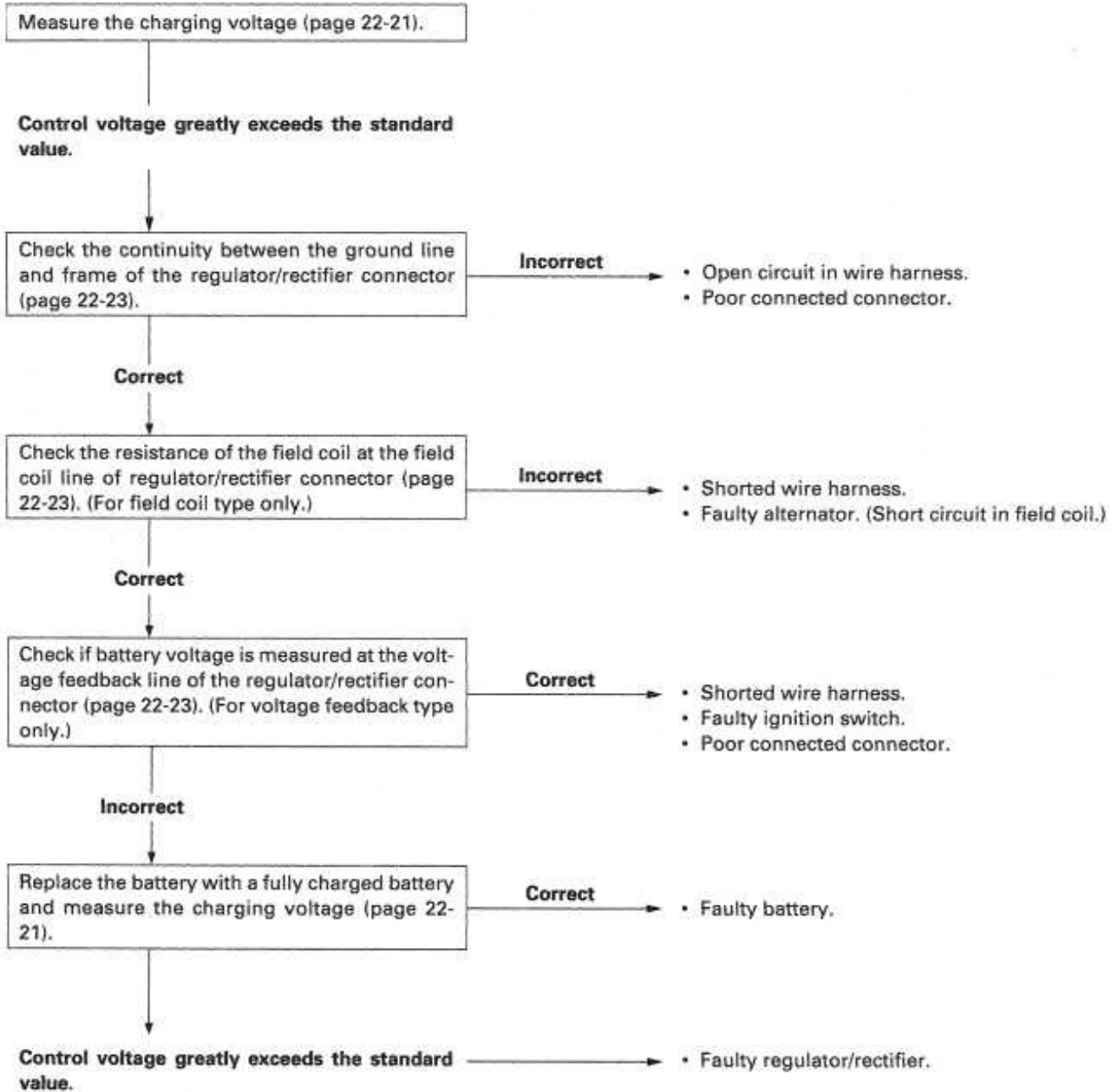

CHARGING SYSTEM

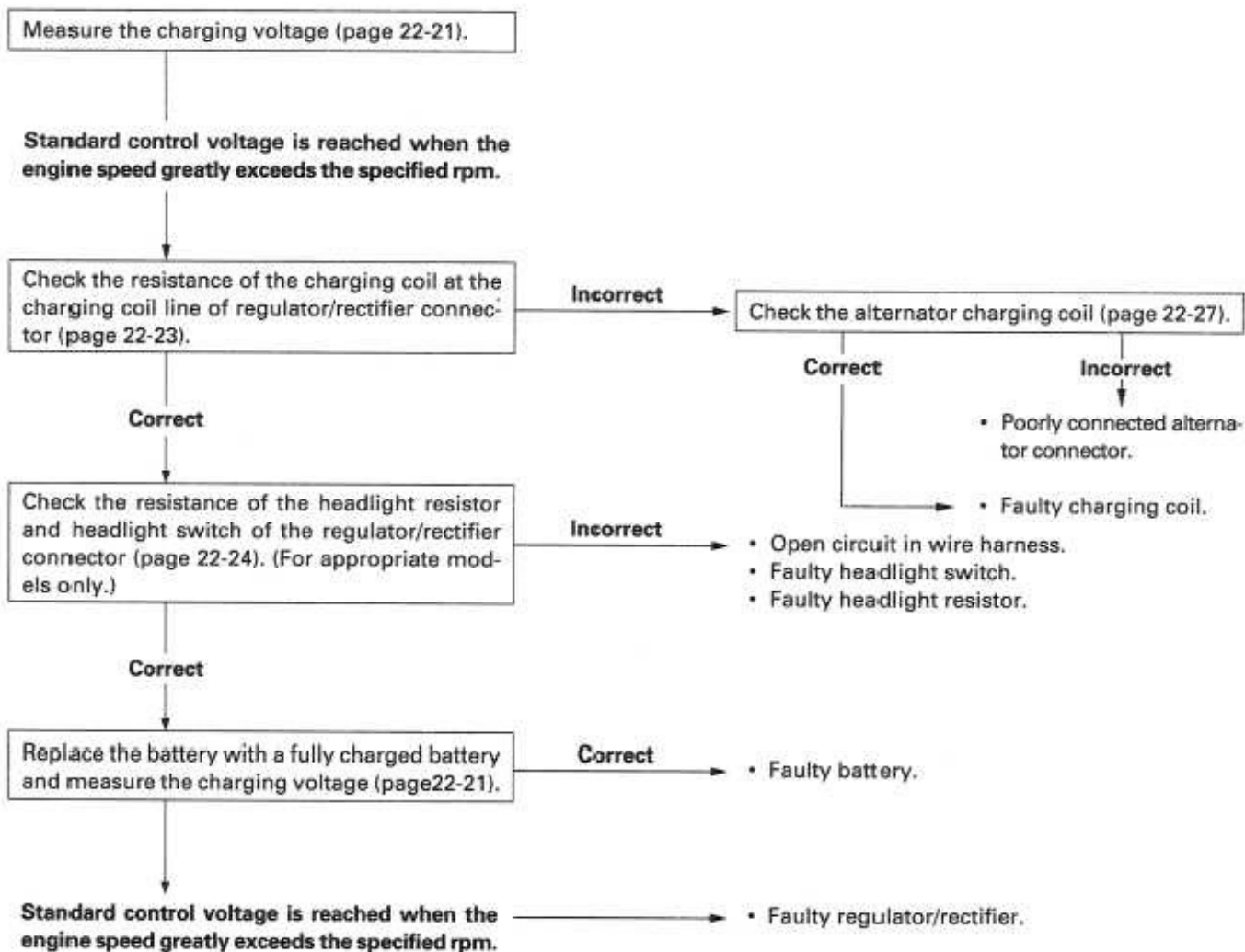

BATTERY DESCRIPTIONS

There are two types of batteries used in Honda motorcycles, scooters and ATVs: the conventional battery and the maintenance free battery.

THE STRUCTURE OF A CONVENTIONAL BATTERY

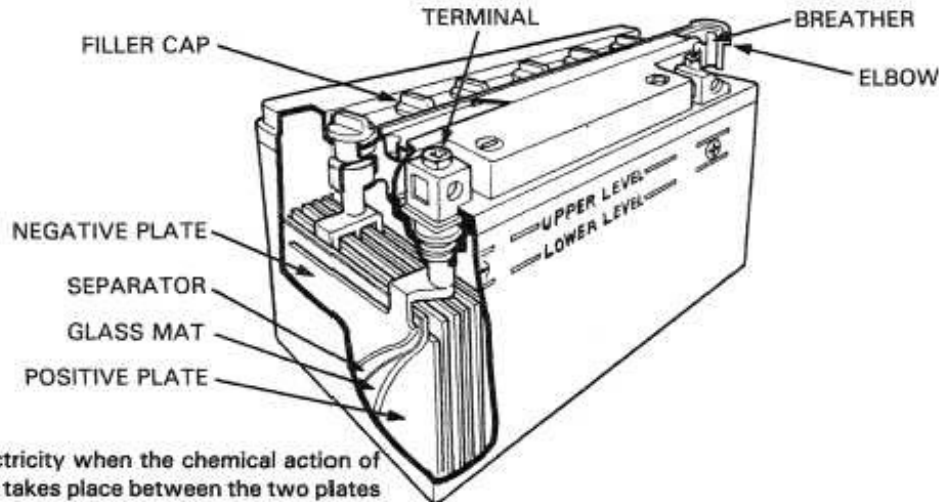

Conventional Battery:

This battery conducts electricity when the chemical action of electrolyte (sulphuric acid) takes place between the two plates (lead peroxide and lead). The sulfate in the electrolyte combines with the plate materials, forming lead sulphate (battery discharge). By passing an electric current back into the battery, the plates revert to lead peroxide and lead (battery charge).

Since the specific gravity of the electrolyte (relative weight of sulphuric acid as compared with an equal volume of water) varies, the battery state of charge is determined by measuring the electrolyte's specific gravity.

⚠ WARNING

- The battery gives off explosive gases; keep sparks, flames and cigarettes away. Provide adequate ventilation when charging or using the batteries in an enclosed space.
- The battery contains sulfuric acid (electrolyte). Contact with skin or eyes may cause severe burns. Wear protective clothing and a face shield.
 - If electrolyte gets on your skin, flush with water.
 - If electrolyte gets in your eyes, flush with water for at least 15 minutes and call a physician immediately.
- Electrolyte is poisonous. If swallowed, drink large quantities of water or milk and follow with milk of magnesia or vegetable oil and call a physician.
- KEEP OUT OF REACH OF CHILDREN.

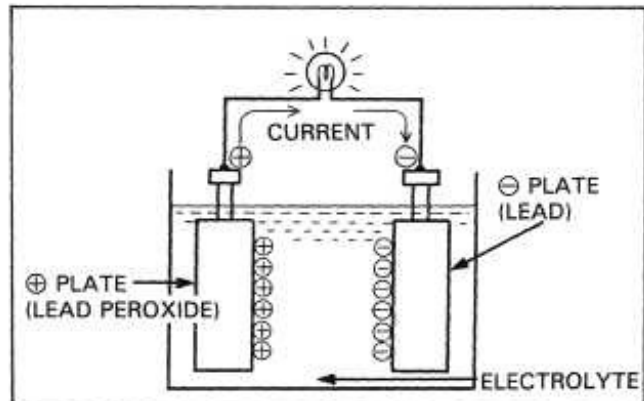

Use only distilled water in the battery.

CAUTION

- Tap water will shorten the service life of the battery.

CAUTION

- Avoid filling the battery above the UPPER LEVEL line to prevent an electrolyte overflow which could corrode the engine or nearby parts.

When you charge the lead/acid battery, electrolysis breaks the water down into its components, hydrogen and oxygen. Because of the generation of these gases, you must remove the filler plugs while charging the battery.

The battery is equipped with a vent, usually routed overboard into tube, to rid it of the gases produced during normal use.

The battery is said to be overcharged when an excess current is supplied to the battery. When the battery is overcharged, volatile gas is emitted from the plates, and electrolyte temperature rises. This temperature rise causes more rapid loss of water from the battery electrolyte. This water loss and temperature rise will shorten the battery life. If left unchecked, water loss and high temperature will damage the battery beyond repair.

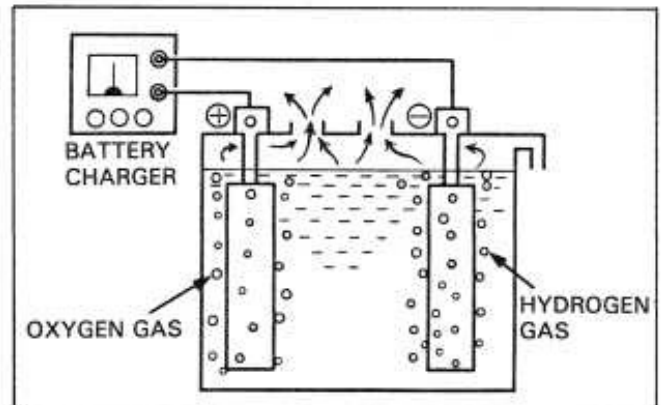

Because the motorcycle battery is constantly subjected to charging and discharging cycles, the water in the electrolyte is boiled off.

When the water is boiled off to the point where the plates become exposed, a white crystalline deposit forms. This process is called sulfation (lead sulfate). The white crystalline lead sulfate, unlike the lead sulfate produced by discharging, is difficult to revert to lead peroxide and lead.

This causes damage to the battery and shortens the battery life. This can occur not only when the electrolyte level is low but also when the battery is discharged for long periods. Remember that the electrolyte level goes down when the water in the battery evaporates. Always add distilled water, not electrolyte.

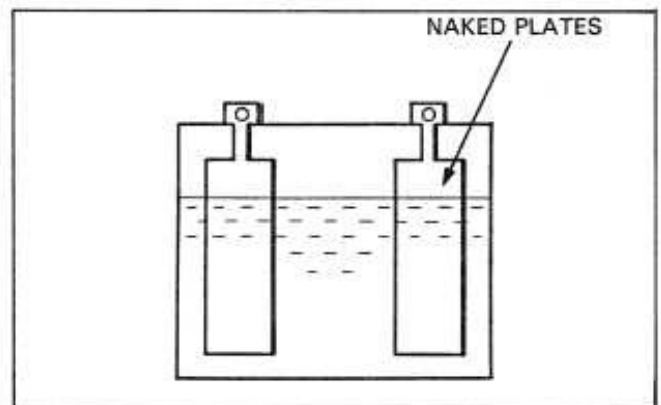

MAINTENANCE-FREE BATTERY

The Maintenance-Free battery is a sealed battery that requires no electrolyte level inspection or periodic refilling.

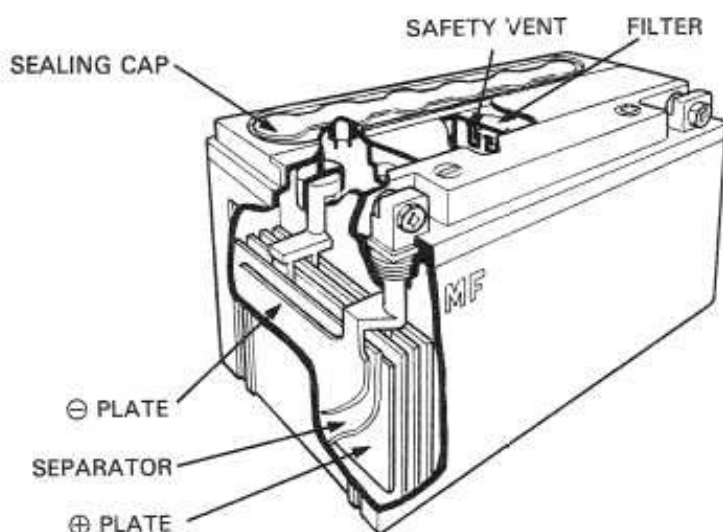

Similar in design to the conventional battery, the MF battery produces hydrogen and oxygen gas. However, the plates are designed not to convert to lead completely. (In its pre-conversion state the lead is called sponge lead.)

When the battery is overcharged and the positive plates produce oxygen gas, the negative plates are not completely converted to lead. Hydrogen gas is not produced.

The oxygen produced from the positive plate reacts with the active material (lead) on the negative plate, and produces water. Therefore, water does not need to be added to MF batteries.

MF batteries have safety valves designed to open when excessive gas is produced. The safety valves close and seal the battery again when the internal pressure returns to normal. A ceramic filter is placed over the safety valves to prevent any internal ignition of the gases produced.

▲ WARNING

- **Electrolyte is poisonous.**
- **Explosive gas can vent from a battery when it is overcharged. For this reason, keep open flames and lit cigarettes away from a battery.**

When replacing the battery, follow the manufacturer's instructions.

CAUTION

- **The MF battery life depends largely on the proper amount of electrolyte being added at the start of service. Use the electrolyte container designated for the specific battery.**

NOTE

- Avoid interchanging conventional and MF batteries. They have different charging components.

CAUTION

- **Removing the sealing caps from the cells of an MF battery may damage the battery.**

MOTORCYCLES WITHOUT BATTERIES

Some motorcycles do not have batteries in their electrical systems. These models power electrical components with the electricity generated by the alternator, which is regulated by an AC regulator. For components using transistors which require DC current, a small rectifier (DC power unit) is used to rectify alternator signals to DC and feed DC current to these components.

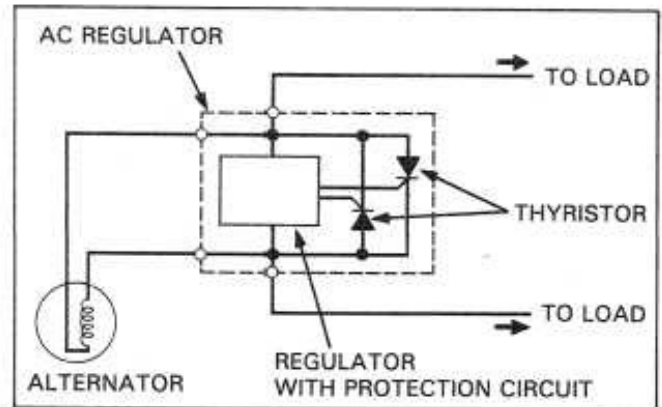

Voltage regulator

To provide a stable current without using a battery, a high power output alternator that feeds sufficient current at low engine rpm is utilized. If the alternator continues supplying current as the engine rpm increases, the excessive current may burn out light bulbs.

To prevent this, the AC regulator maintains the output voltage of the alternator in the specified range. Some AC regulators have a protection circuit built into the alternator regulator circuit to prevent abrupt voltage increases on cold engine starts.

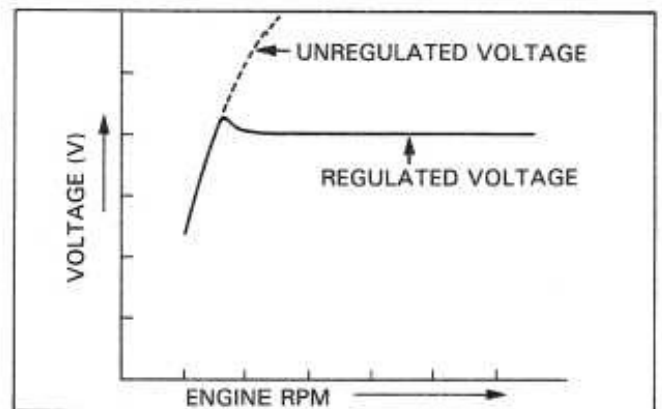

The current generated from the alternator flows directly to the loads at voltage levels lower than the regulated voltage value. As the engine rpm increases, the regulator detects the rise and directs current to thyristor, shorting the alternator output to ground. When the alternator voltage goes over the specified voltage, the regulator cuts off the excess voltage, maintaining a constant voltage output.

DC voltage unit

Although most electrical components use AC current, there are systems such as the engine oil warning system which require DC current to operate their transistors and LEDs.

Therefore, a compact and light weight DC voltage unit rectifies the AC current to DC current for these systems.

These are systems and components used specifically for AC: alternating flash turn signals, whose front and rear signals flash alternately, and the AC horn which use electrical circuits and components designed for models without batteries.

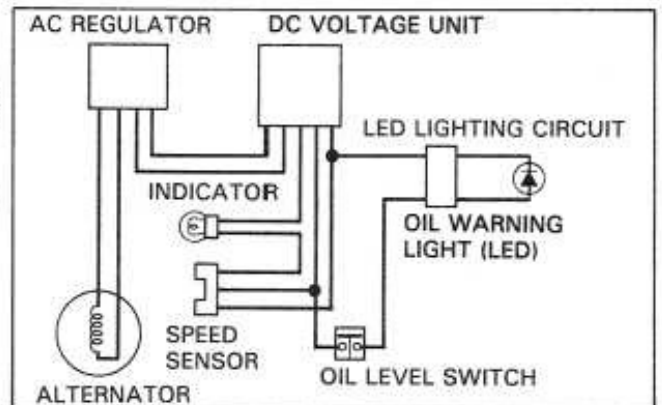

BATTERY REMOVAL/INSTALLATION

REMOVAL

Turn off the ignition switch.
Disconnect the negative (-) battery cable first, then remove the terminal cover and disconnect the positive (+) cable.

▲ WARNING

- Disconnecting the positive (+) cable first could cause an accidental direct short between the two terminals when the tool disconnecting the terminal contacts the frame. The spark could ignite or damage the battery.

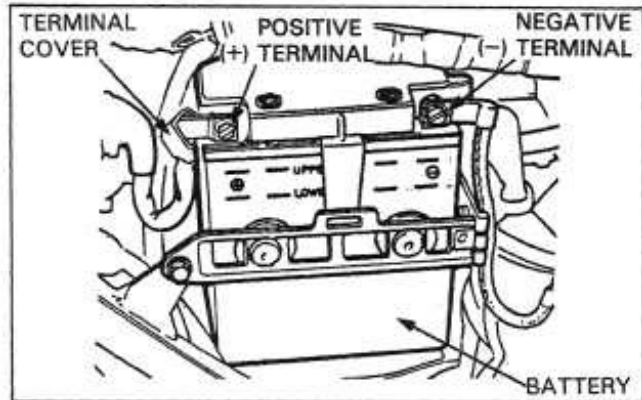

For conventional batteries, always disconnect the breather tube before removing battery.

NOTE

- Some electrolyte may remain in the breather tube.

▲ WARNING

- Keep electrolyte away from your eyes or skin while disconnecting the battery breather tube.

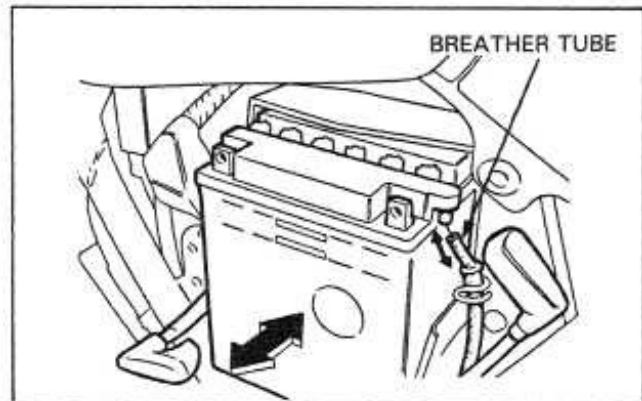

INSTALLATION

Be sure to route the breather tube properly on conventional batteries.

▲ WARNING

- Take care to prevent spilling electrolyte from the breather tube because it can corrode components.
- Take care with the breather tube. Pay attention to the following points:
 - Connect the breather tube securely.
 - Follow the caution label and route the tube accordingly.
 - Avoid bending or squeezing the breather tube. Check that the breather tube has not been bent or squeezed by the surrounding components. Failure to replace a bent or squeezed breather tube may lead to a pressure buildup that can cause the battery to explode.

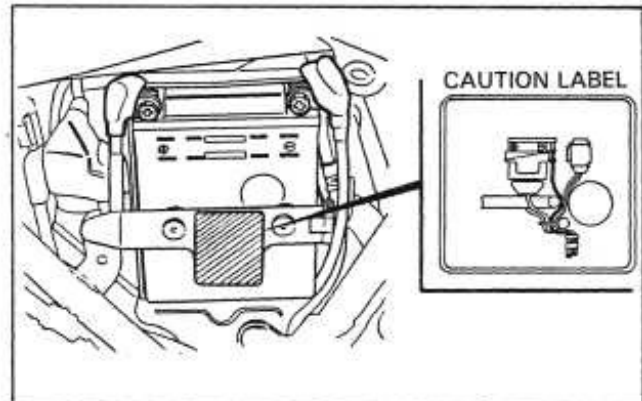

Place the battery into the frame.

Secure the battery with the battery holder.

CAUTION

- Improper installation may cause vibrations which can damage the battery case.

To prevent shorting, always connect the positive (+) cable first.

After installing the battery, coat the terminals with clean grease to prevent corrosion.

Connect the battery positive (+) cable and secure terminal cover onto the positive terminal then connect the negative (-) cable.

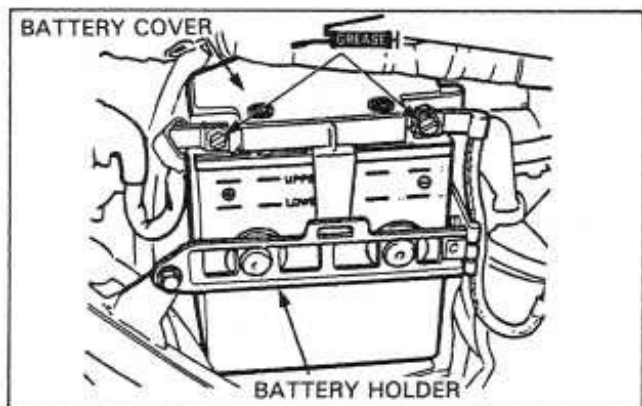

BATTERY TESTING/CHARGING

BEFORE USING THE TESTER:

- Place the tester on a clean, flat and level surface.
- Be sure the work area is well ventilated, clear of flammable materials, and free from heat, humidity, water or dust.
- Always take the battery to the work bench/test area — continually moving of the tester or operation on an uneven surface may shorten its service life and reduce sensitivity over a period of time.

NOTE

- Always clear the work area of flammable materials such as gasoline, brake fluid, electrolyte, or cloth towels when operating the tester, the heat generated by the tester may cause a fire.

BATTERY TESTING

Use the following steps to remove the battery from the motorcycle:

- 1) Disconnect the negative (-) terminal lead.
- 2) Remove the battery holder.
- 3) Remove the battery cover (when applicable).
- 4) Disconnect the positive (+) terminal lead.
- 5) Remove the battery breather tube (when applicable).
- 6) Pull out the battery.
- 7) If necessary, clean the battery terminals.

Securely connect the tester's positive (+) cable first — then connect the negative (-) cable.

NOTE

- For accurate test results, be sure the tester's cables and clamps are in good working condition and that a secure connection can be made at the battery.

S TOOL

BATTERY TESTER

07GMJ-0010000

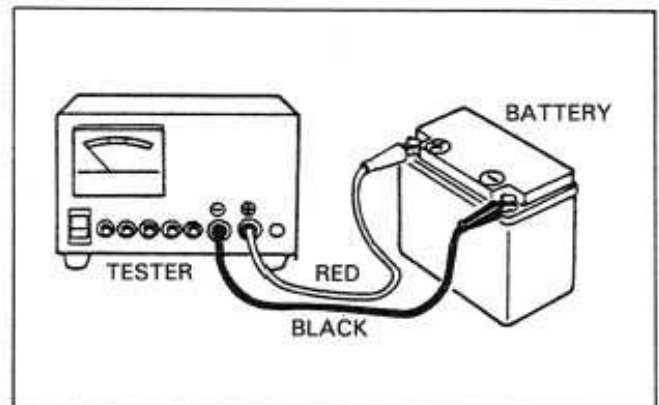

Set the temperature switch to "HIGH" or "LOW" depending on the ambient temperature.

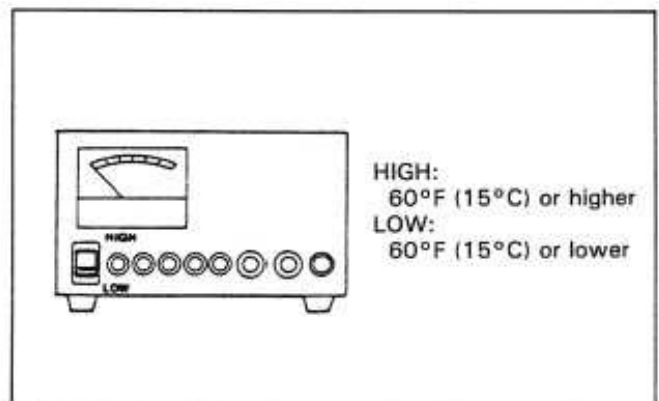

BATTERIES/CHARGING/LIGHTING SYSTEM

Push in the appropriate test button for **three seconds** and read the condition of the battery on the meter.

NOTE

- Be sure you've selected the correct test button that corresponds to the battery being tested — see the chart below. For the first check, **DO NOT** charge the battery before testing — test it its "as is".

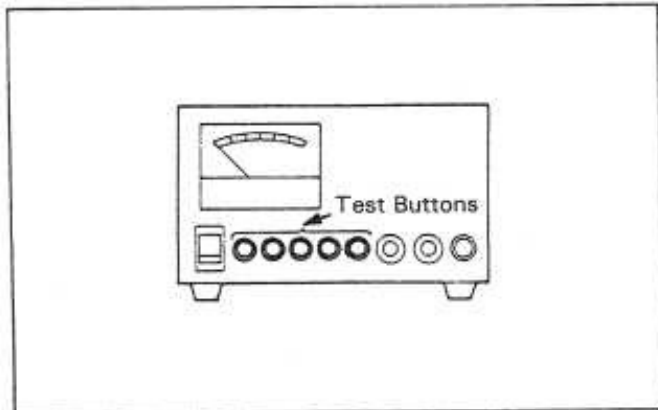

Capacity	-3 Ah	3.5 Ah-5 Ah		5.5 Ah-9 Ah	9.5 Ah-16 Ah		16.5 Ah-30 Ah
Type	YB25L-C-1-2 YB3L-A	TB4L-B YB4L-B-Ca YB5L-B YB5L-B-Ca	YT4L-12 YT4L-12B YT5L-12 YT5L-12B	12N9-4B-1 YB9(L)-B YB9-B-CA YB9A-A YTH9-12B	YB12A(L)-A YB12A-B YB9-B-Ca YB14L-A1 YB14A-A2	YB16B-A HYB16A-A YT12-12 YTH12-12B YTH14-12B	YB18(L)-A Y50-N18L-A

CAUTION

- To avoid damaging the tester, only test batteries with an amperage rating of less than 30 Ah.
- Tester damage can result from overheating when:
 - The test button is pushed in for more than three seconds.
 - The tester is used without being allowed to cool for at least one minute when testing more than one battery.
 - More than ten consecutive tests are performed without allowing at least a 30-minute cool-down period.

NOTE

- The result of a test on the meter scale is relative to the amp. hour rating of the battery. **ANY BATTERY READING IN THE GREEN ZONE IS OK.** Batteries should only be charged if they register in the **YELLOW** or **RED** zone.

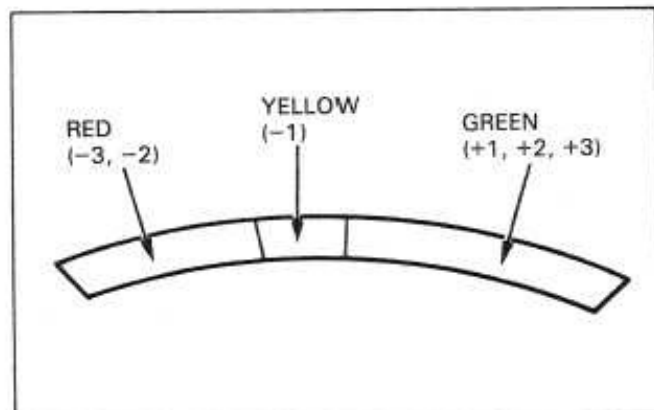

EXAMPLE: Gold Wing batteries (Y50-N18L-A, 18 AMP HOUR) using the 16.5-30 amp. hour setting may read in the **GREEN** zone, but close to the **YELLOW** (charge) zone. As long as the meter reads in the **GREEN** zone, the battery is OK.

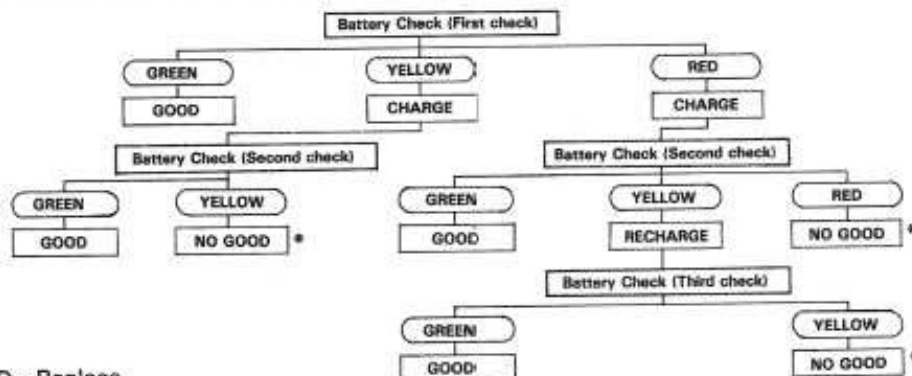

* NO GOOD = Replace

BATTERY CHARGING

Before Operating The Charger

- Be sure the area around the charger is well ventilated, clear of flammable materials, and free from heat, humidity, water and dust.
- Clean the battery terminals and position the battery as far away from the charger as the leads will permit.
- Do not place batteries below the charger — gases from the battery may corrode and damage the charger.
- Do not place batteries on top of the charger. Be sure the air vents are not blocked.

▲ WARNING

- Always clear the work area of flammable materials such as gasoline, brake fluid, electrolyte, or cloth towels when operating the tester, or the heat generated by the tester may cause a fire.

⚠ TOOL

BATTERY CHARGER MC1012/2

1. Turn the Power Switch to the OFF position.
2. Set the Battery Amp. Hr. Selector Switch for the size of the battery being charged.
3. Set the Timer to the position indicated by the Honda Battery Tester; RED-3, RED-2, or YELLOW-1. If you are charging a new battery, set the switch to the NEW BATT position.
4. Attach the clamps to the battery terminals — RED to Positive, BLACK to Negative.

Connect the battery cables only when the Power Switch is OFF.

▲ WARNING

- Connecting the cables with the Power Switch ON can produce a spark which could ignite or explode the battery.

5. Turn the Power Switch to the ON position.
6. When the timer reaches the "Trickle" position, the charging cycle is complete. Turn the Power Switch OFF and disconnect the clamps.

NOTE

- The charger will automatically switch to the Trickle mode after the set charging time has elapsed.

7. Retest the battery using the Honda Battery Tester and recharge if necessary following the flow-chart on page 22-12.

NOTE

- For accurate test results, let the battery cool for at least ten minutes or until gassing subsides after charging.

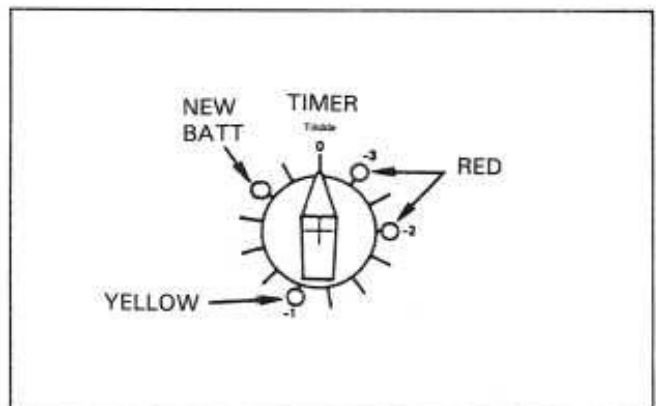
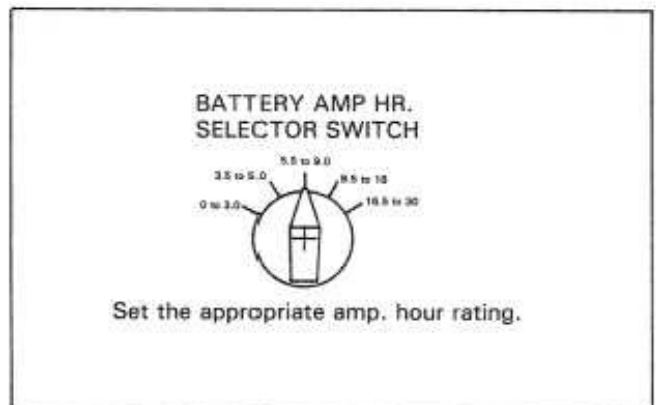
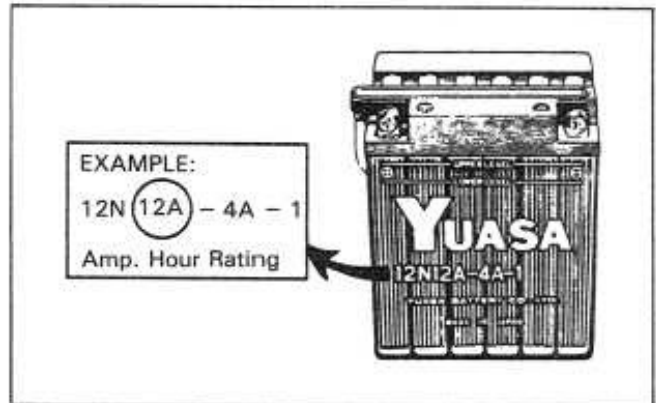

BATTERIES/CHARGING/LIGHTING SYSTEM

CHARGING SYSTEM DESCRIPTION

The charging system basically consists of the following components.

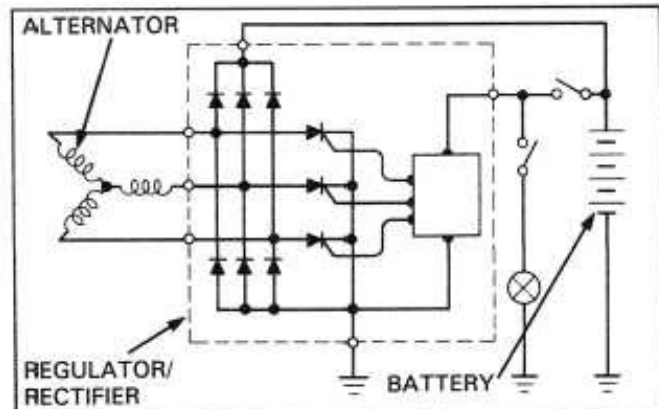

Component name	Function
Regulator/rectifier	<ul style="list-style-type: none">Regulates voltage so that it stays within the specified range.Converts alternating current (AC) to direct current (DC).
Alternator	<ul style="list-style-type: none">A generator producing current (AC) which is powered by engine revolution.
Battery	<ul style="list-style-type: none">Stores regulated DC current.

ALTERNATOR TYPES

The alternator consists of a rotor and a stator. The rotor consists of a flywheel made up of a series of magnets, and is usually driven by the crankshaft. The stator consists of a series of soft iron poles around which are wound coils of wire.

When the engine starts, the rotor rotates with the crankshaft. When the outer (or inner) core of the coil passes through the magnetic field, current is generated. This is called electromagnetic induction, and other systems such as the ignition and AC lighting systems generate power under the same principle.

In addition, the rotor acts as additional flywheel weight, smoothing out engine pulsations at low engine rpm.

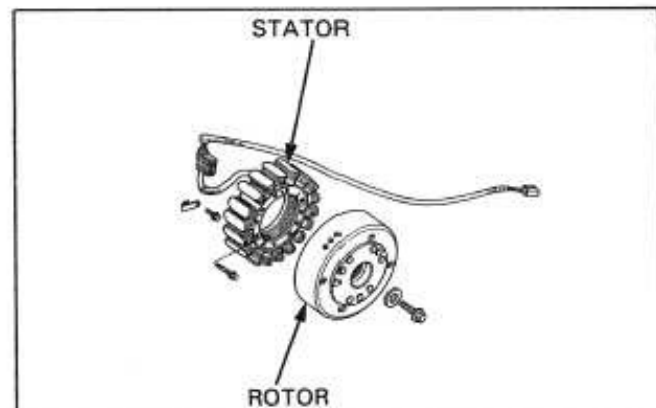

Permanent Magnet Type

This is the most common type of alternator with the stator placed inside the rotor. The permanent magnet is assembled on the inner walls of the rotor.

In general, the stator consists of several coils producing power for the charging, ignition and lighting systems. Current for charging the battery is generated by the charging coil.

Brushless Excited Field Coil Type

The other alternators described here are located within the engine. This alternator is exposed outside the engine because it is air cooled. In general, the rotor speed is multiplied by gears or chains connected to the crankshaft. This type is the most powerful among the triple phase alternators and is primarily used for power on large displacement motorcycles.

Excited field coil-type alternators do not utilize a permanent magnet. Instead, the field coil magnetizes the rotor and generates power as the rotor passes the coil.

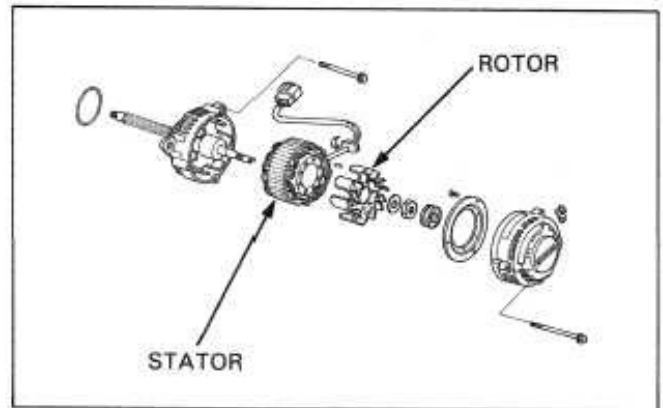

Excited Field Coil Type With Brushes

This type has a field coil placed inside the rotor. Current flows through the brushes to the field coil and electromagnetically induces the rotor. This generator has a strong magnetic force, large output, and is small and lightweight.

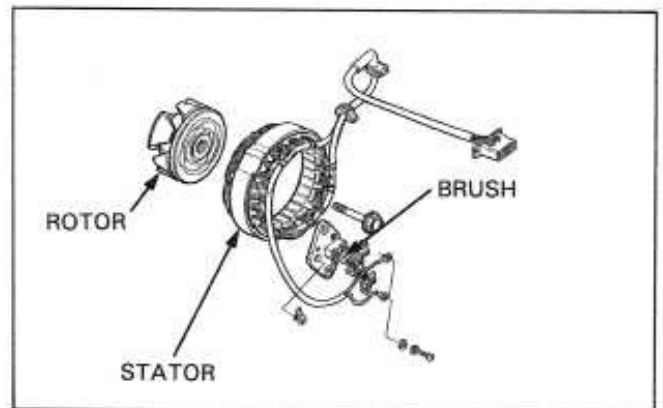

ALTERNATOR FUNCTION

Single Phase Output Type

Since this type uses only one charging coil, the output voltage is a single-phase AC wave. The output frequency varies depending on the number of magnets on the rotor, and the speed of the rotor.

The generator in the diagram on the right has two pairs of magnets, and its output has two cycles for every rotation of the rotor.

The single phase output type has a low output, and its small size is best suited for engines of small displacement and a small electrical load.

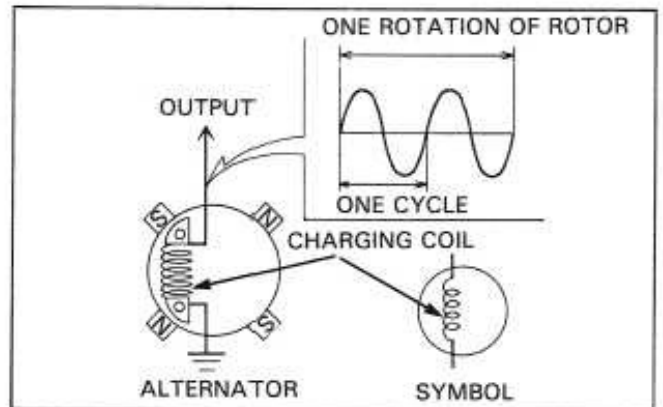

BATTERIES/CHARGING/LIGHTING SYSTEM

Triple Phase Output Type

This type consists of three coils connected to each other, producing three single phase alternating currents. The output of the alternator is three single phase AC wave forms where each is 120° out of phase with the others.

The symbol for this alternator has only three coils as in the diagram. The actual stator coil consists of several coils connected in series.

The triple phase output type is used in engines of medium to large displacement with large electrical loads. Depending on how the coils are connected, there are two symbols for this type. Servicing is the same for both types.

Some triple phase output types use an electromagnetically induced type alternator. The excited field coil type alternator feeds current to the field coil to magnetize the rotor which then acts like a permanent magnet. The symbol for this type has a field coil along with the charging coil.

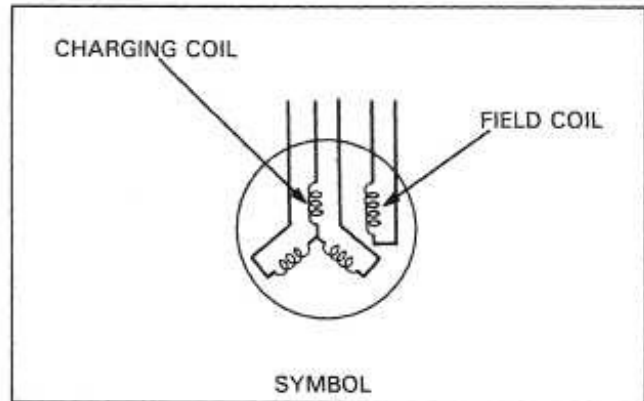
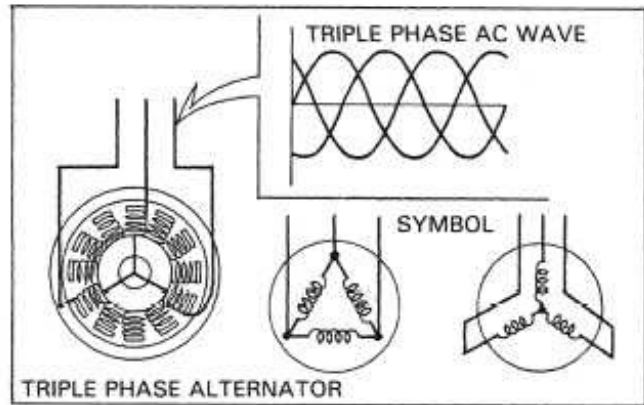

REGULATOR/RECTIFIER

The regulator/rectifier uses semiconductors such as thyristors which radiate heat in operation. For this reason, these components use printed circuit boards which are resined onto an aluminum case. The case has several fins for better heat dissipation.

As the engine revolutions increase, the output voltage of the alternator also increases. The function of the regulator/rectifier is to keep this AC output voltage within a certain range and to convert the AC output voltage to DC voltage — for powering various components and charging the battery.

Type of Regulator/Rectifiers

A regulator/rectifier may be classified as one of several types, based on the method of regulation and rectification. The chart below shows the different types of regulator/rectifiers.

Input AC wave form	Rectification method	Voltage feedback method	Regulation method
Single phase	Half-wave rectification	Internal voltage feedback	SCR shorted
Triple phase	Full wave rectification	Battery voltage feedback	

Since the input wave form is the same as the output wave form of the alternator, refer to the alternator section for the types of input wave form.

Single Phase, Half-Wave Rectifiers

(Diode rectification method)

This method uses only a diode to convert alternating current to direct current. The diode allows current to flow in one direction only. When a single phase AC waveform flows through the diode, the negative voltage of the waveform is cut off and the positive voltage drops slightly. As a result, the output consists of the positive half-cycles of the input waveform. The signal is said to have been rectified because only half cycles are utilized. This is called half-wave rectification.

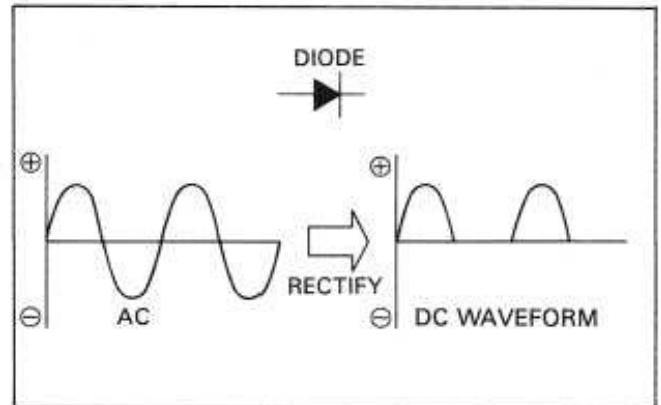

Single phase half wave rectification is used in models with small electrical loads.

The single phase half wave rectifier utilizes two voltage feedback methods.

(Internal voltage regulation method)

The circuit illustrated at right is the most basic regulator circuit.

The signal from the charging coil is half-wave rectified through diode D1, which is inside the regulator/rectifier circuit, and is then fed to the battery.

Voltage is regulated by the voltage regulation circuit and the SCR (thyristor).

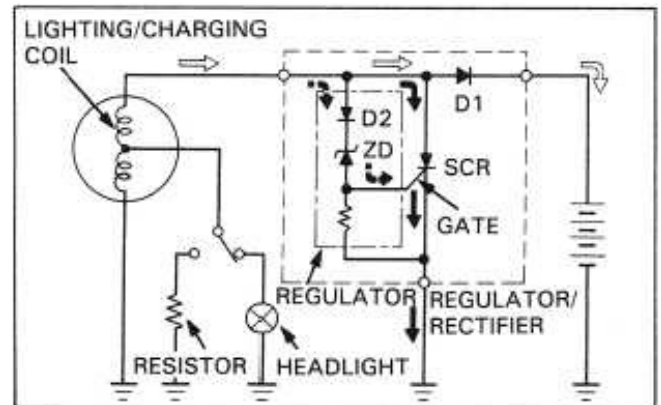

As the engine rpm (revolutions per minute) increases, the alternator output increases and is rectified by diode D2. This signal then goes to the zener diode (ZD).

Current flows in the normal direction of the zener diode but does not flow in the reverse direction until a certain amount of voltage is applied in the reverse direction. When this voltage is reached, the zener diode abruptly conducts current in the reverse direction. In this way, current is fed to the gate of SCR which then turns ON.

When the SCR turns ON, the output from the alternator is shorted to ground through the SCR. This explains why the battery becomes overcharged if the ground wires of the regulator/rectifier are broken or poorly connected.

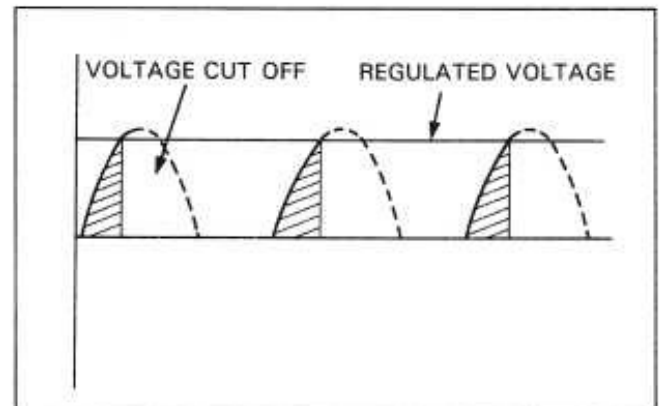

For alternators with a combined charging/lighting coil (charging and lighting systems powered by the same coil), the headlight lighting system affects battery charging. Since the input of the lighting system is taken from the charging coil, if the lighting coil load is unsuitable battery charging will be unstable. To prevent this from happening, when the headlight is off, the output from the charging coil is connected to a resistor equivalent to the impedance of the headlight.

Keep in mind that if the lighting output lines are broken or shorted, or if the switch has contact problems, the charging system is adversely affected.

BATTERIES/CHARGING/LIGHTING SYSTEM

(Battery)

This method is similar to the method explained previously except that the voltage regulation is done after the signal is converted to DC at the input of the battery. Since this method regulates output voltage of alternator after it is rectified, its charging is precisely controlled.

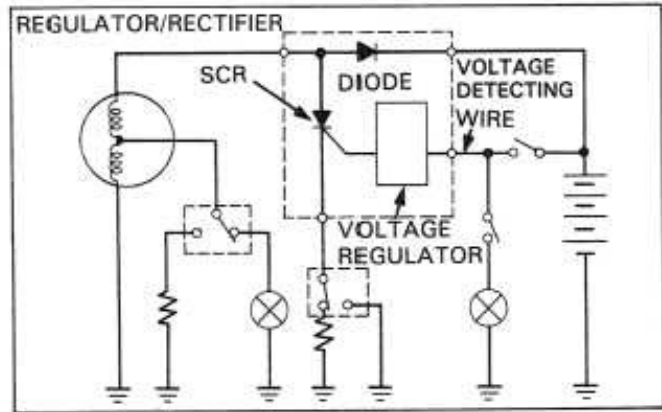

In order to regulate the current going to the headlight, there is sometimes a resistor connected to the ground wire of the regulator/rectifier through a switch. Since the charging coil powers the headlight as well, the headlight flickers and dims when the output of the charging coil is shorted to ground through the SCR. This happens because when the ground wire of the regulator/rectifier is connected to ground, the resistance AB becomes less than AC, so less current is diverted to the headlight. In order to keep current flowing to the headlight steadily, a resistor, whose value is greater than resistance between AC, is placed between AD.

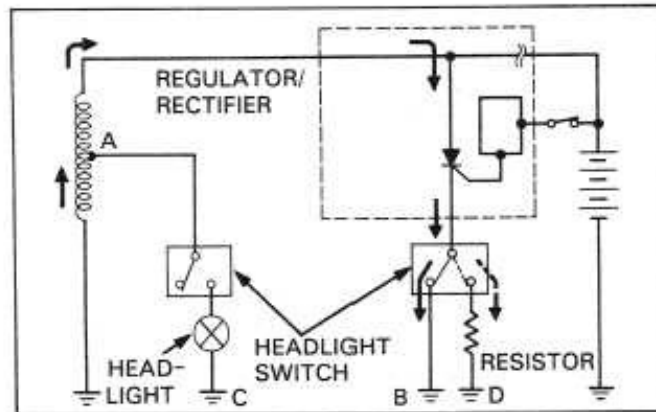

(SCR switching regulation/AC regulator built in type)

This regulation method is used for models with small displacement engines. Unlike the type above, the SCR is used for switching and the ZD (zener diode) is used for voltage regulation.

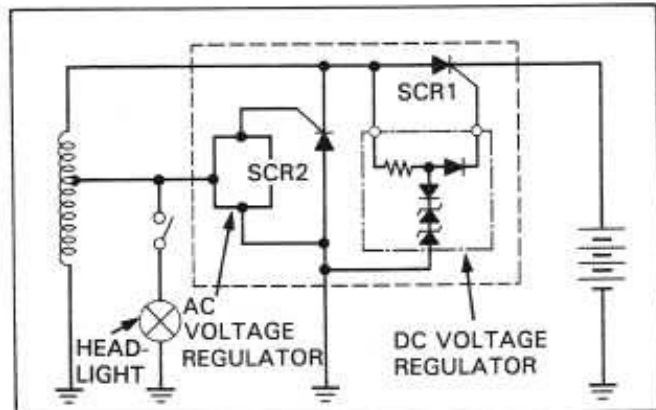

The output of the alternator goes to the gate of SCR1 via the DC voltage regulator. When the voltage at the cathode of SCR1 is less than the voltage at the gate, the thyristor turns ON and conducts current to the battery. When AC output of the alternator changes from positive to negative, the gate voltage of SCR1 becomes zero, turning OFF the thyristor and cutting off the negative signal to the battery.

The output voltage is regulated by ZD1 and ZD2 which turn ON (and short to ground) when the output voltage of the charging coil increases beyond a specified value. When the ZDs turn ON, the SCR1 turn OFF by reducing the gate voltage of thyristor and causes the output voltage regulated.

The regulator may overcharge the battery if the ground wire is broken or if there are poor connections at the terminals.

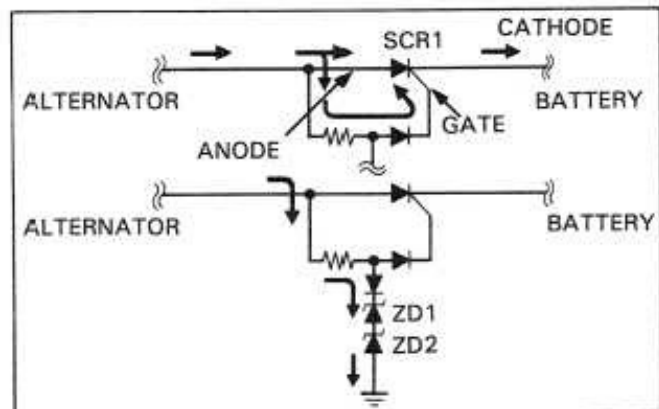

AC Regulator Function:

The AC regulator regulates the voltage to the headlight; no resistor is required. When the negative output of the charging coil reaches a certain voltage, the AC regulator feeds current to the gate of SCR2 and turns it ON. The SCR2 is shorted and a negative current to the coil regulates its output voltage.

Since the negative output voltage of the charging coil is not used for charging the battery, the AC regulator has no effect on charging the battery.

However, since when the negative output of the coil is cut off the headlight voltage is also cut off, the AC regulator regulates the output voltage to the headlight.

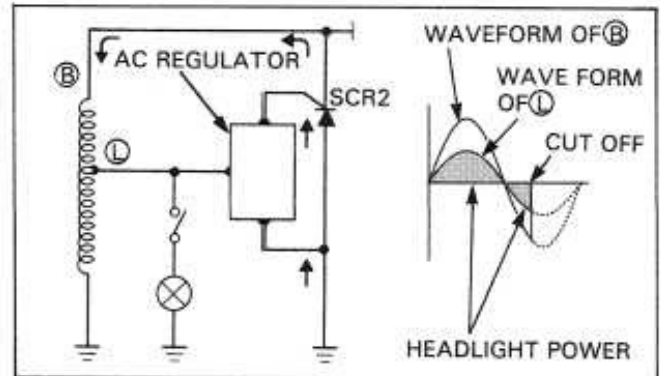

Single Phase, Full-Wave Rectifiers

These are used on medium engine displacement models. Compared to the half-wave rectifier, the full-wave rectifier is more efficient in using the alternator output for charging the battery.

In order to convert the AC output of the alternator to DC, the diodes are arranged as in the diagram at right, inside the regulator/rectifier. When the alternator is positive, the current flows through D1 → battery → D2 (shown by the white arrows) and when the alternator is negative the current flows through D3 → battery → D4 (represented by the black arrows).

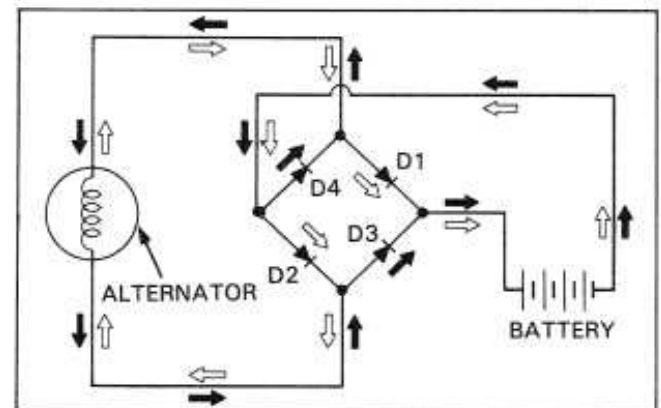

In this way, the AC output of the alternator is converted to a DC waveform.

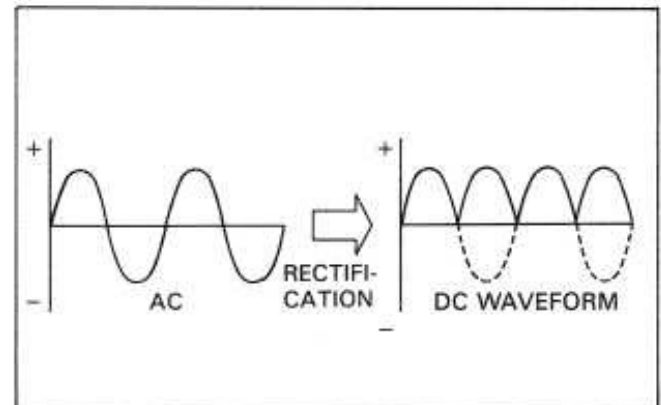

Similar to the single phase half-wave rectifier, the full-wave rectifier may be a battery voltage feedback type or an internal voltage feedback type. The circuit at right shows the battery voltage feedback rectification method.

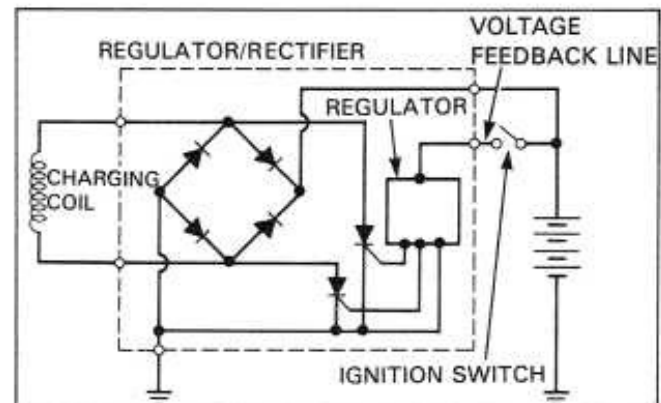

BATTERIES/CHARGING/LIGHTING SYSTEM

AC Regulator

Most medium engine displacement motorcycles have independent lighting and charging coils. For these models, the lighting coil has its own independent AC regulator. The regulator detects the AC voltage of the lighting coil inside the regulator/rectifier and shorts out all excessive output.

There are regulators which regulate both positive and negative outputs and ones which regulate negative output only.

Since these regulators have lighting and charging coils that operate independently, even if one of the coils does not work, the other is not affected.

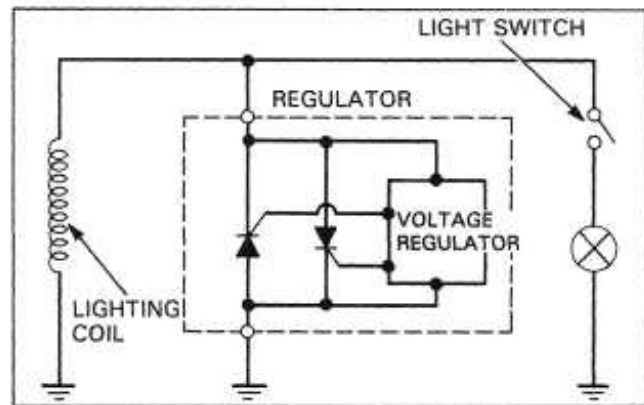

Triple Phase Full-Wave Rectifier

This type is mainly used in medium and large engine displacement models. The rectifier is connected directly to the three phase alternator. This circuit has no lighting coil but instead, the battery feeds DC current to the lighting system.

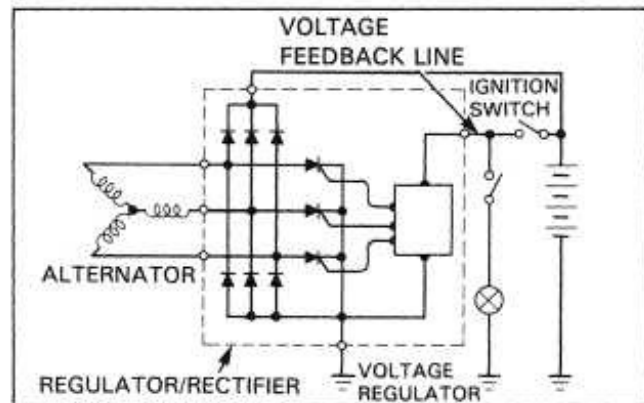

The rectified waveform of the triple phase AC output is more stable than the single phase AC type.

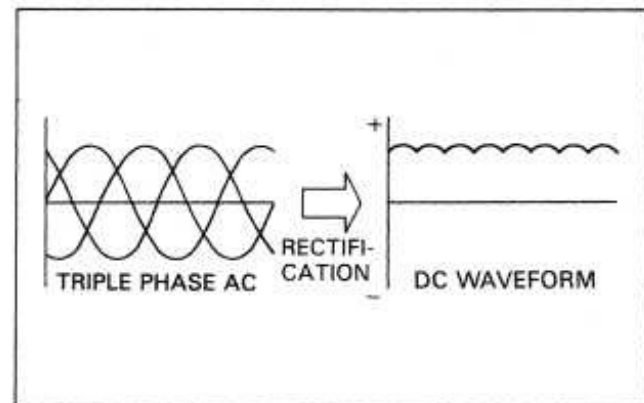

Triple Phase Full-Wave Rectifiers With Field Coils

This type regulates the alternator output using the current flowing through the field coil. The regulator/rectifier has a voltage regulator for the field coil. The voltage regulator detects the voltage at the battery and feeds current to the base of a transistor, turning it ON. When the transistor is ON, the battery feeds current through the ignition switch → field coil → transistor → ground. The field coil magnetizes the rotor, and the alternator generates power.

When the alternator reaches a certain voltage, the voltage regulator turns off the transistor and cuts off current to the field coil, hence the alternator stops generating power.

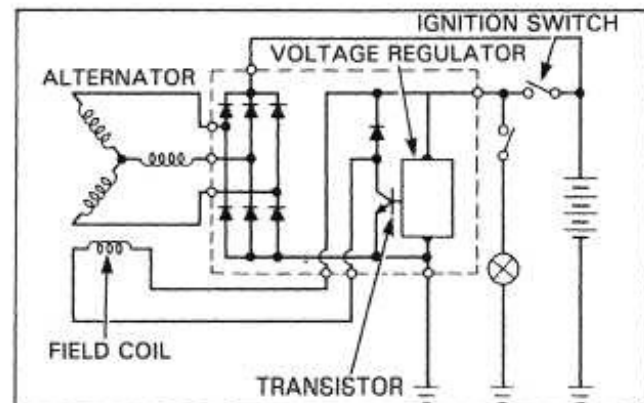

The voltage regulation is performed by the high frequency ON/OFF cycle of the alternator. When the DC voltage of the output waveform is measured, the reading will always be less than the specified peak voltage.

A broken wire in the field coil in this type of system will result in insufficient alternator charging. If the ground wire of the field coil is shorted to ground (transistor shorted), the battery will be overcharged.

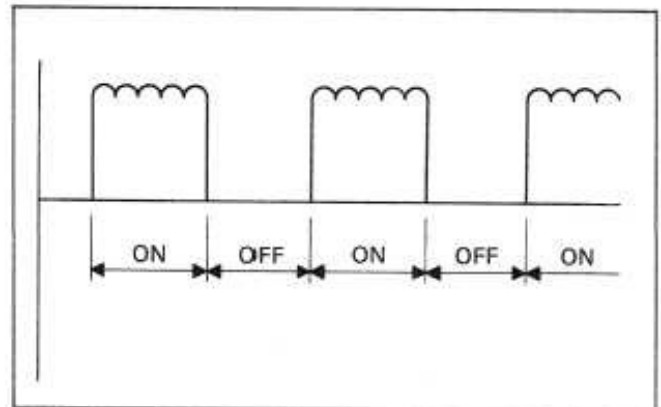

CHARGING SYSTEM INSPECTION

CHARGING VOLTAGE INSPECTION

After warming up the engine, connect a voltmeter between the battery terminals.

▲WARNING

- Be careful not to short any wires.
- Always turn the ignition off when conducting the test. Disconnecting the battery terminal(s) when current is flowing may damage the tester or electrical component.

For models with no tachometer, connect an engine tachometer. Turn the headlight ON (Hi beam) and start the engine. Gradually increase the engine speed and measure the voltage between the battery terminals.

If the voltage reading increases to the control voltage from the battery voltage when the engine speed reaches around the rpm that the charging starts, the charging is normal.

NOTE

- The rpm which the charging starts vary depends on the battery condition and/or load of the electrical component(s).

If the battery voltage drops quickly or the battery eventually dies out even if the charging is normal, it is likely the battery's effective life span has passed.

For the following conditions, the problem is most likely related to the charging system. Conduct the following inspection.

- ① Standard control voltage is not reached when the engine speed increases.
 - Open or shorted circuit of the wire harness, poorly connected connector.
 - Open or shorted circuit of the AC generator.
 - Faulty regulator/rectifier.
 - The battery used is bad.
- ② Control voltage greatly exceeds the standard value.
 - The battery used is bad or incorrect (the capacity is underrated).
 - Faulty regulator/rectifier.
 - The battery used is bad.
- ③ Standard control voltage is reached when the engine speed greatly exceeds the specified rpm.
 - Excessive electric load due to the use of light bulbs beyond the specified rating.
 - The battery used is bad.

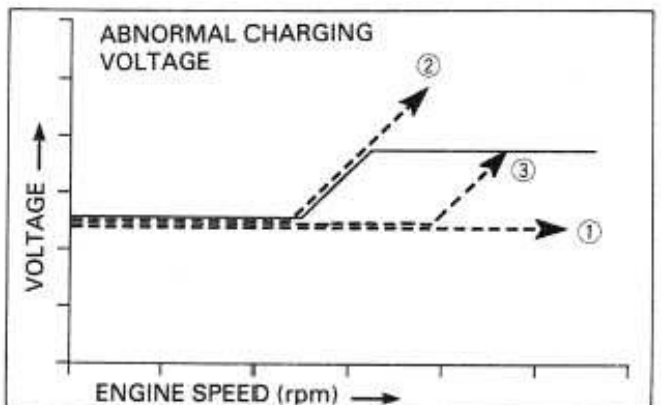
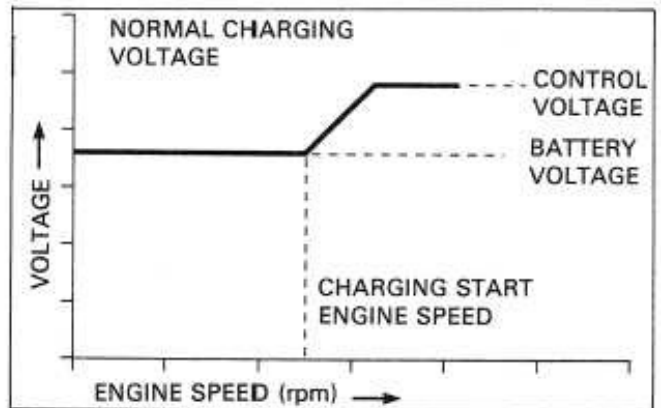
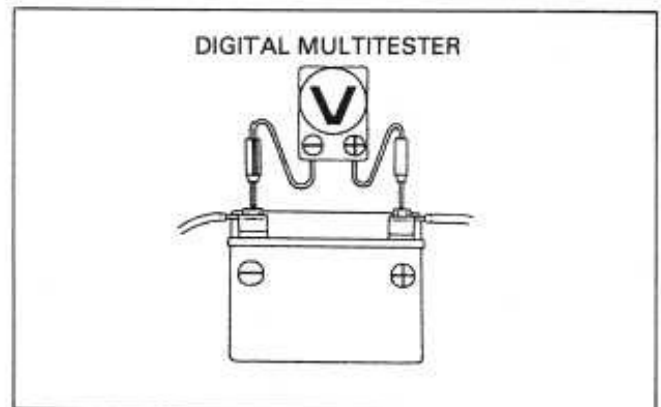

BATTERIES/CHARGING/LIGHTING SYSTEM

LEAK TEST

Turn off the ignition switch, and disconnect the ground (-) cable from the battery.

Connect an ammeter between the negative (-) terminal and ground cable.

With the ignition switch off, measure the current leakage.

NOTE

- When measuring current using a tester, set it to a high range initially and then lower the range setting to an appropriate level. Current flow larger than the range selected may blow out the fuse in the tester.
- The ignition switch must be off during the leakage inspection. A sudden surge of current may blow out the fuse in the tester.

If current leakage exceeds the standard value, there is probably a short circuit in the system.

Locate the short by disconnecting connections one by one and measuring the current.

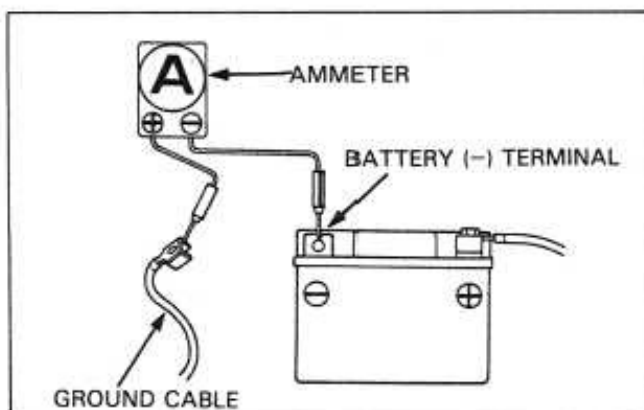

REGULATOR/RECTIFIER INSPECTION

Use the troubleshooting chart to make a preliminary diagnosis of the service problem.

Since the regulator/rectifier is an electrical component which uses semiconductors, can not be serviced. Instead, the unit connectors are checked.

Inspect the regulator/rectifier at the terminals of each connector.

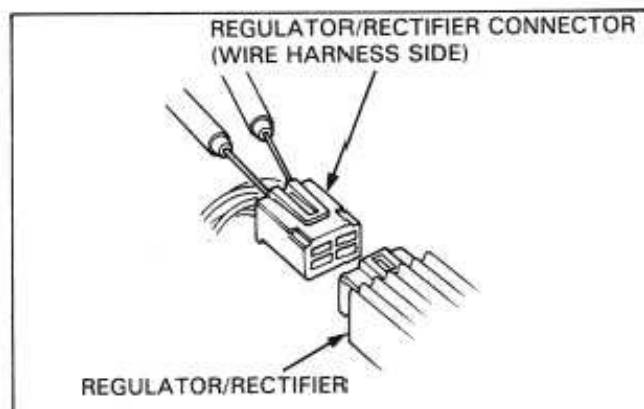
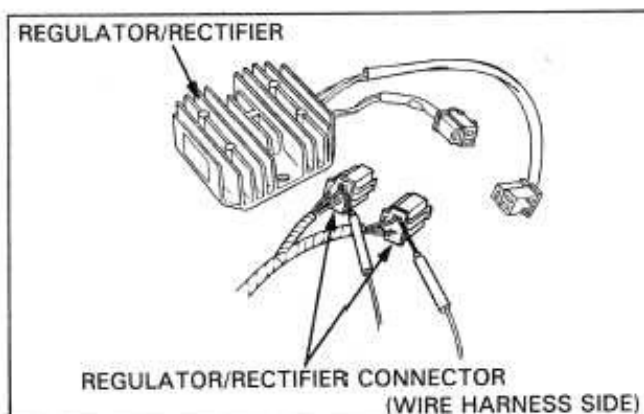

BATTERIES/CHARGING/LIGHTING SYSTEM

Items (wire colors)	Inspection
Battery wire (red/white or red)	Check that there is voltage between battery line (+) and ground line.
Ground wire (green)	Check continuity between ground and frame.
Voltage detection line (black) (external voltage detection type)	Check that there is battery voltage between voltage detection line (+) and ground wire when the ignition is ON.
Charging coil (refer to Model Specific manual)	Check that the resistance of the coil is within the specified range.
Charging/lighting coil (refer to Model Specific manual)	Check that the resistance of the coil is within the specified range. (Because the lighting system effects the resistance value, follow the steps below.)

With integrated charging/lighting coils (charging and lighting shared by a single coil), disconnect the coil output connector when measuring resistance. The headlight resistance will be included in the ohmmeter measurement if the connector is not disconnected. (If the headlight connector is connected, the measured resistance will be smaller, because the headlight resistor is connected in parallel.)

- For lighting systems whose headlight connector is connected to a resistor when the headlight is turned OFF, either disconnect the handlebar switch connector or the lighting output line of the charging/lighting. (Refer to the diagram at right.)

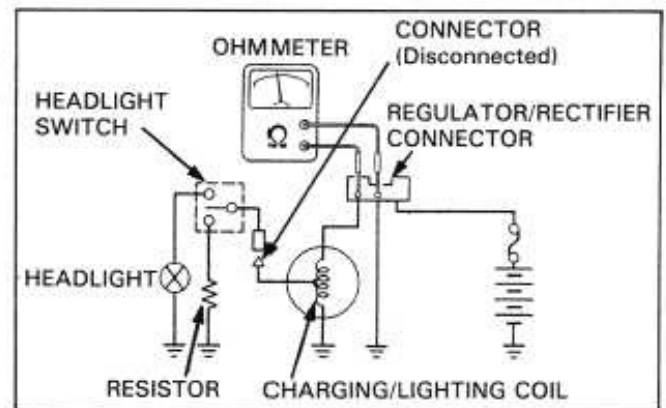

- For lighting systems that have a headlight ON and OFF switch, just turn off the headlight switch. (Refer to the diagram at right.)

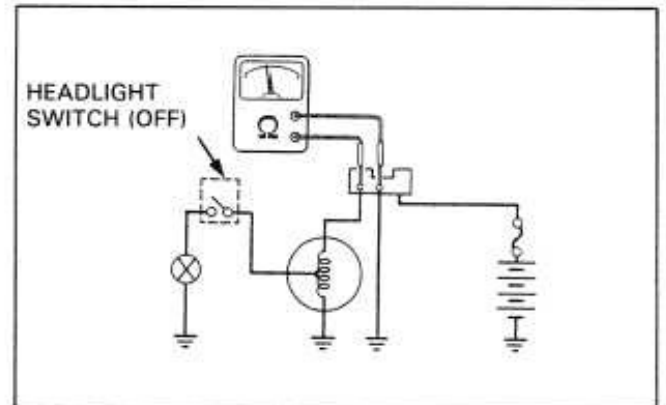

- Disconnect the starting enrichment thermal valve connector if applicable. (See to the diagram at right.)

If the readings taken based on the chart above reveal that there is an abnormality, check the following:

- Battery wire → Broken wire harness (repair or replace)
- Ground wire → Broken wire harness (repair or replace)
- Charging coil → Check the charging coil of the alternator
- Charging/lighting coil → Check the charging/lighting coil of the alternator

If the resistance value of the alternator is normal (i.e., the resistance value measured by the above method is different from the alternator resistance).

Check for a broken or shorted wire harness between the regulator/rectifier and alternator, or for a poor connection at the alternator connector.

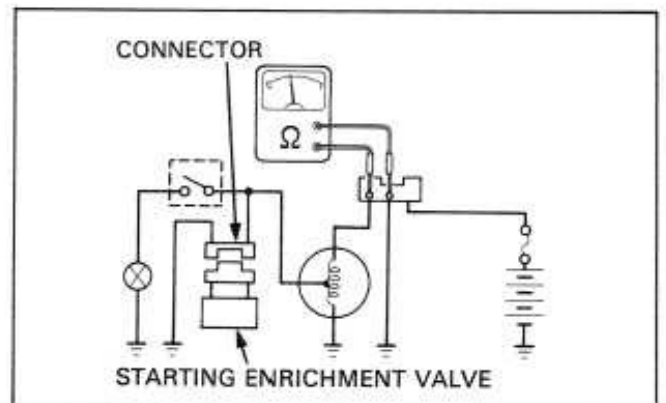

HEADLIGHT VOLTAGE INSPECTION

Regulator/Rectifier With Built-in AC Regulator:

For a regulator/rectifier with a built-in AC regulator, measure the headlight lighting voltage.

CAUTION

- Failure to measure the headlight voltage may lead to electrical damage of lighting components.

If the model is not equipped with a tachometer, connect an engine tachometer.

Remove the headlight and start the engine.

Turn the headlight on Hi-beam.

With the headlight wires still connected, measure the headlight lighting voltage between the terminals connected to blue (+) and green (-) wires.

Gradually increase the engine speed and read the voltage at the rpm specified in the Model Specific manual.

Refer to the Model Specific manual for service data.

Select the AC range on your multimeter. (AC current flows to the headlight).

Use the specified multimeter. The measured headlight-regulated voltage may vary depending on the multimeter used because of the characteristics of the output waveform.

SPECIFIC MULTIMETER

- KS-AHM-32-003 (KOWA Digital type; USA only)
- 07308-0020001 (SANWA Analogue type)
- TH-5H (KOWA Analogue type)

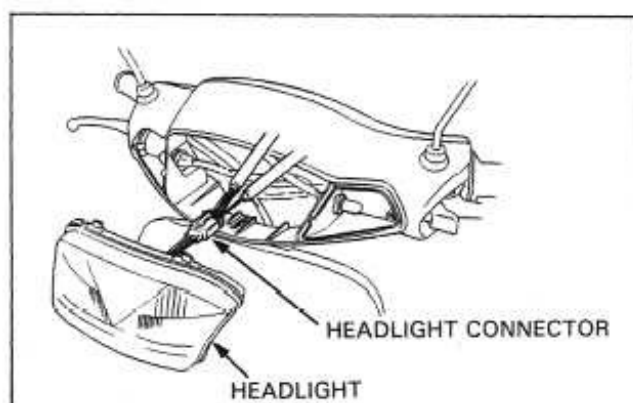

Resistor Inspection

For models with a headlight resistor or an starting enrichment valve, measure the resistance of the resistor.

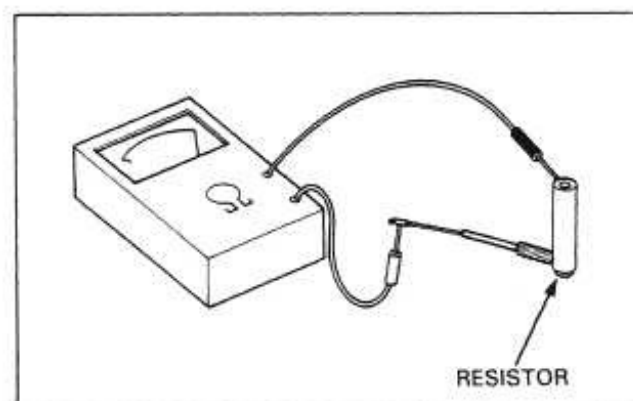

AC Regulator Type:**NOTE**

- This section explains the inspection procedures for models which have an independent lighting coil powering the headlight system.
- For models with combined lighting and charging coil, refer to the regulator/rectifier inspection section.

For models not equipped with tachometer, connect an engine tachometer.

Remove the headlight as shown, and switch the headlight to Hi-beam.

With the headlight wires connected, start the engine and measure the headlight lighting voltage between the blue (+) and green (-) wire terminals.

Increase the engine speed gradually and read the voltage at the specified engine rpm. Refer to the Model Specific manual for service data.

Select the AC range on your multimeter. (AC current flows to the headlight).

Use the specified multimeter. The measured headlight-regulated voltage may vary depending on the multimeter used because of the characteristics of the output waveform.

SPECIFIC MULTIMETER

- KS-AHM-32-003 (KOWA Digital type; USA only)
- 07308-0020001 (SANWA Analogue type)
- TH-5H (KOWA Analogue type)

- If the headlight lighting voltage is abnormally high, check the alternator connector and the alternator unit.
- If there is no headlight lighting voltage, check:
 - For loose or poor contact at a connection in the lighting circuit
 - For continuity at the dimmer switch
 - The AC regulator
 - The alternator lighting coil

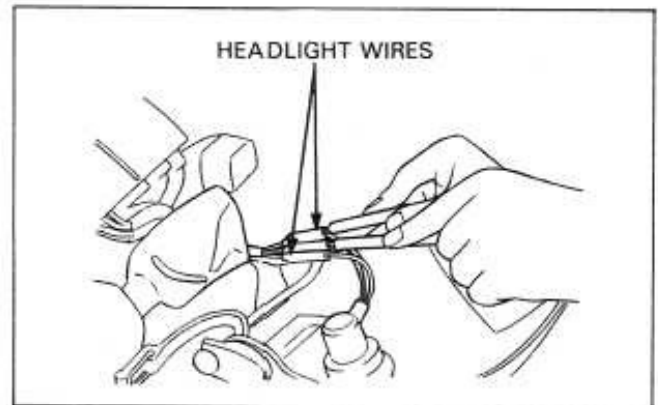

BATTERIES/CHARGING/LIGHTING SYSTEM

AC REGULATOR INSPECTION

After checking that all connections are correct and secure, inspect the alternator unit by measuring the resistance between the terminals. (Refer to the Model Specific manual for service data.)

NOTE

- The resistance readings will not be accurate if the probes touch your fingers.
- Use one of the following recommended multimeters.
- Other testers may not allow you to obtain the specified values. This is due to the characteristic of semiconductors, which have different resistance values depending on the applied voltage.

SPECIFIC MULTIMETERS

–KS–AHM–32–003 (KOWA Digital type; USA only)

–07308–0020001 (SANWA Analogue type)

–TH–5H (KOWA Analogue type)

- Select the following range.

SANWA Tester: $k\Omega$

KOWA Tester: $\times 100 \Omega$

- An old, weak multimeter battery could cause inaccurate readings. Check the battery if the multimeter registers incorrectly.
- When using the Kowa multimeter, remember that all readings should be multiplied by 100

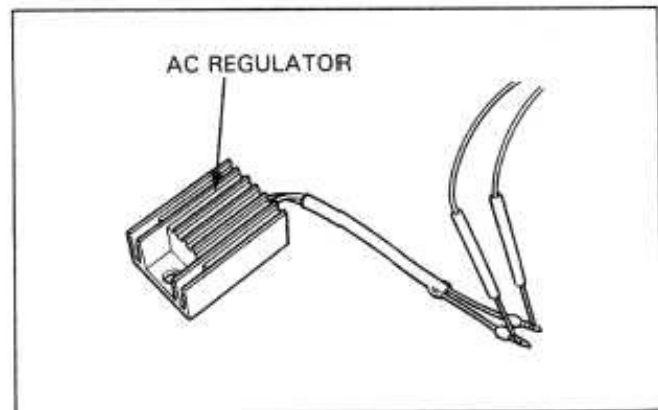

If the resistance between the terminals is out of standard value, replace the regulator with a new one.

ALTERNATOR

CHARGING (CHARGING/LIGHTING) COIL INSPECTION

NOTE

- It is not necessary to remove the alternator from the engine.

Disconnect the alternator connector and check continuity between the wires.

(A) For single phase coils whose end is grounded, measure the resistance between the output line and ground. (If the measured value is not correct, check for continuity between the stator ground wire and ground, and between the alternator cover ground wire and ground.)

(B) For coils with two output lines, measure resistance between the lines. Check that there is no continuity between engine ground and the output lines.

(C) For single phase, combined charging/lighting coils, measure the resistance at the charging output line and at lighting output line.

(D) For three phase coils, measure resistance between each output line, and check that there is no continuity between each output line and ground.

If the tested resistance, components show infinite (∞) replace the stator.

If measurements are only slightly off the specified value, the stator may not need to be replaced. Check other areas and decide if replacement is required.

STATOR REMOVAL

Remove alternator cover. (Oil may spill out.)

Hold the flywheel rotor with a holder and remove rotor bolt.

S TOOL

UNIVERSAL HOLDER
ROTOR HOLDER

07725-0030000 or
07725-0040000

CAUTION

- Choose the correct holder. Using the wrong tool may damage components. Refer to the Model Specific manual for the correct holder.

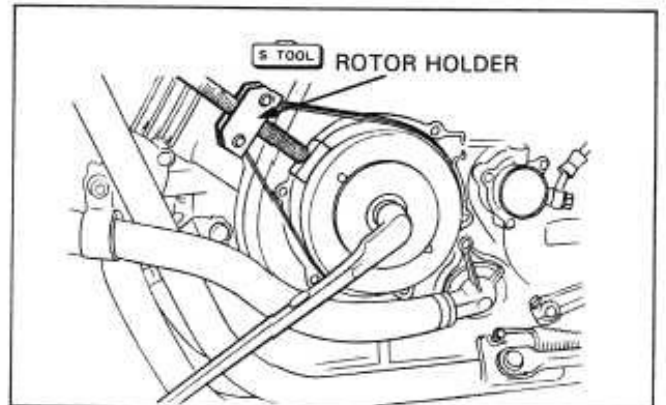
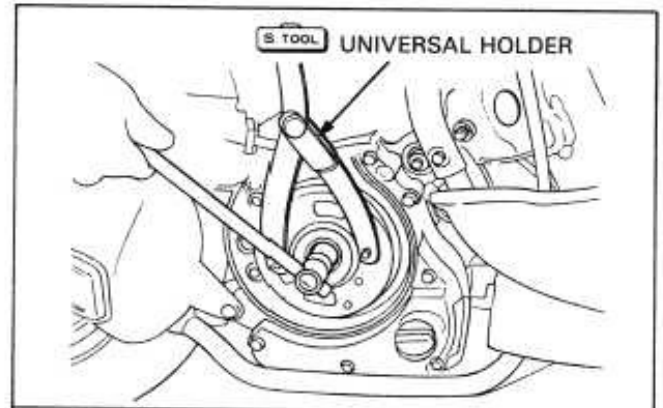
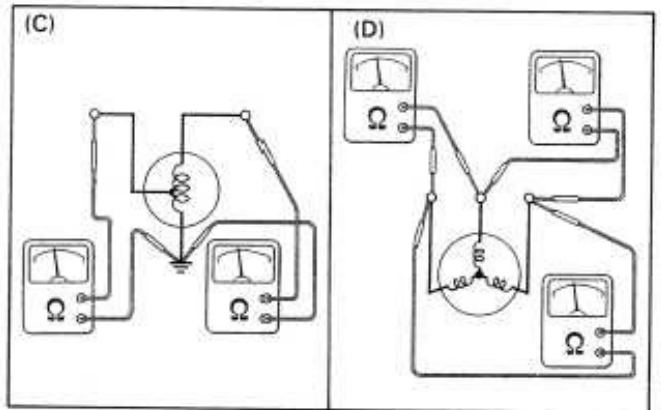
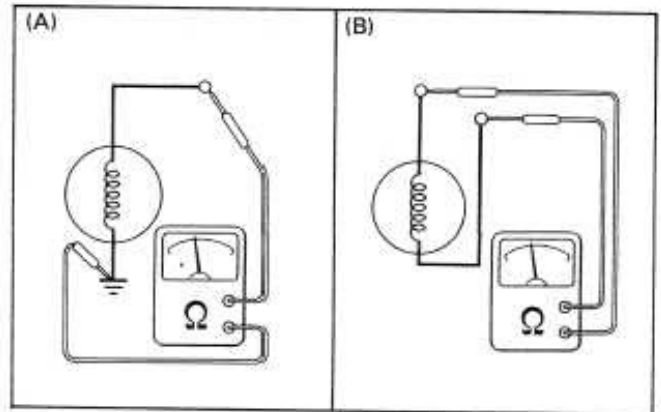

BATTERIES/CHARGING/LIGHTING SYSTEM

Insert the flywheel puller into the rotor and remove the rotor.

5 TOOL

FLYWHEEL PULLER
ROTOR PULLER

07733-0010000 or
07733-0020001

To remove the rotor, screw in the puller attachment, hold it securely with a wrench, and then screw in the puller shaft.

CAUTION

- Strong hammering on the puller shaft may damage the rotor.
- Always use a holder and a puller to remove the rotor. Do not try to remove the rotor by hammering directly on it. The crankshaft or other components could be damaged.

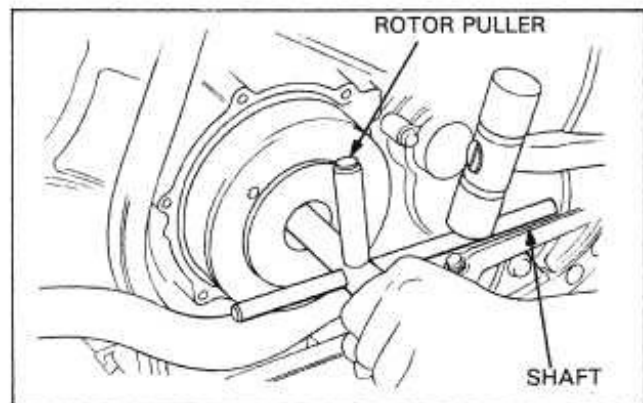
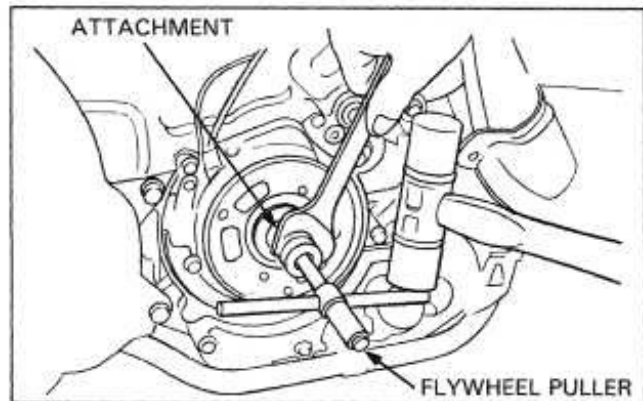

Remove the woodruff key and put it where it won't be lost.

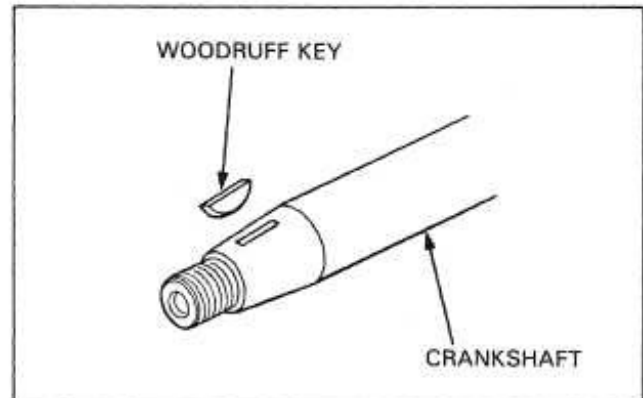

STATOR REMOVAL

Disconnect the alternator connector.

Remove the bolts (or screws) securing the alternator wire to the cover or engine.

Remove the stator.

Stator bolts are often secured with a locking agent. Use an impact driver to remove the bolts.

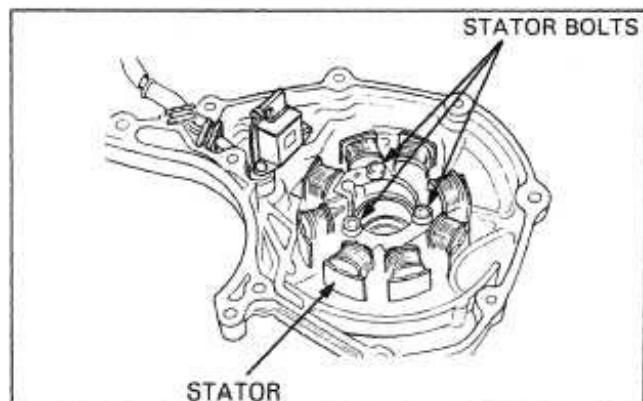

STATOR INSTALLATION

Install the stator in the crankcase cover.
Apply a locking agent to the bolt (or screw) threads and tighten them to the specified torque.

CAUTION

- If the stator bolts/screws work loose, they may come into contact with the rotor and cause damage.

Route the stator wire correctly on the crankcase cover.

NOTE

- Route the stator wire so that it will not come into contact with the rotor.
- If there is a wire clamp or clip, secure the wire with it.
- Apply sealant to the grommet groove to prevent oil or water leakage.

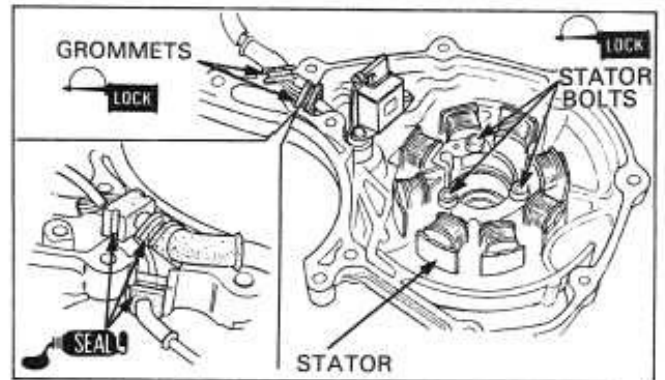

ROTOR INSTALLATION

Clean the tapered portion of the crankshaft.

If the rotor is installed over dust or dirt on the taper, the taper will not make secure contact with the rotor and there will be excessive force on the woodruff key.

Insert the woodruff key into the key groove in the crankshaft.

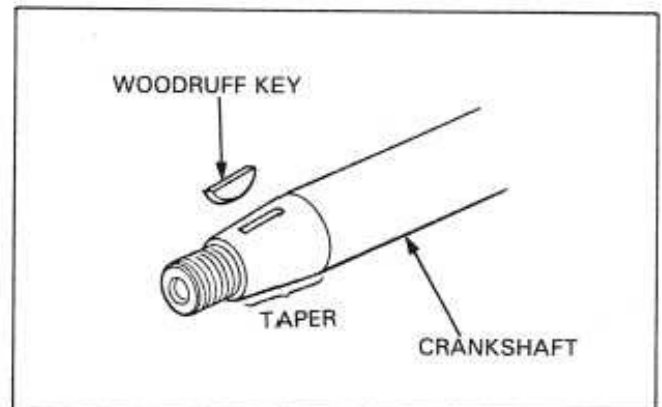

Set the rotor groove over the woodruff key and install the rotor on the crankshaft.

Tighten the rotor bolt (or nut) with your fingers.

CAUTION

- Before installing the rotor, check that no nuts or bolts are magnetically attached to the rotor. Installing the rotor with anything attached to it could damage the stator coil.

Hold the flywheel rotor with a holder and tighten the bolt (nut) to the specified torque.

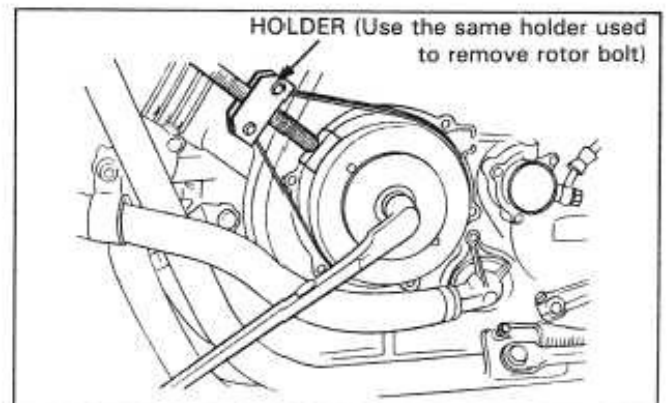

BATTERIES/CHARGING/LIGHTING SYSTEM

Before bolting on the crankcase cover, check that the wires are not pinched.

Install the crankcase cover onto the engine.

CAUTION

- Use the crankcase (white metallic) ground bolt to ensure continuity between the engine and crankcase cover. (All other crankcase bolts are black.) The white bolt must be grounded properly to allow the electrical system to operate normally.

NOTE

- For reassembly, install the white metallic bolt in the case hole with the unpainted seating surface.

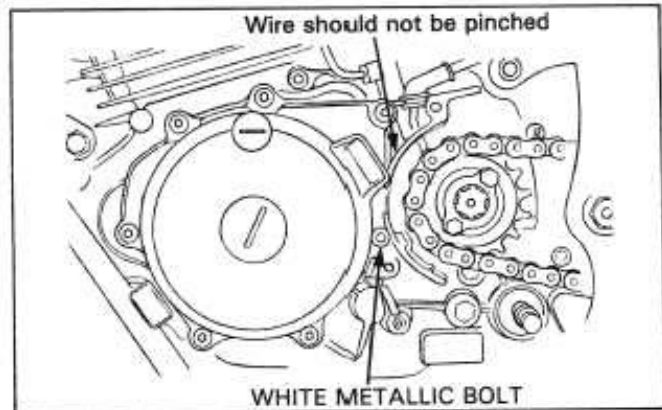

23. IGNITION SYSTEMS

SERVICE INFORMATION	23-1	IGNITION SYSTEM INSPECTION (PEAK VOLTAGE MEASUREMENT METHOD)	23-13
TROUBLESHOOTING	23-1	IGNITION COIL	23-17
SYSTEM DESCRIPTIONS	23-4	SIDE STAND IGNITION CUT-OFF SWITCH	23-19
SPARK TEST	23-11		
IGNITION TIMING	23-12		

SERVICE INFORMATION

GENERAL

- Follow the steps described in the troubleshooting flow chart when servicing the ignition system.
- The CDI and transistorized ignition system use an electrically controlled ignition timing system. No adjustments can be made to the ignition timing.
- For multi-cylinder engines, a rough diagnosis can be made by identifying the cylinder whose spark timing is incorrect.
- The ignition control module may be damaged if dropped. Also, if the connector is disconnected when current is flowing, excessive voltage may damage the unit. Always turn off the ignition switch before servicing.
- A faulty ignition system is often related to poorly connected connectors. Check those connections before proceeding.
- For models with an electric starter, make sure the battery is adequately charged. Using the starter motor with a weak battery results in a slower engine cranking speed as well as a weak spark at the spark plugs.
- Use spark plugs of the correct heat range. Using spark plugs with an incorrect heat range can damage the engine. Refer to chapter 2 for servicing spark plugs.

TROUBLESHOOTING

- The explanations in the following troubleshooting charts are based on a general-type CDI and transistorized ignition system. In case of special-type devices, the inspection sequences and procedures may be different. Refer to the Model Specific manual for detail information.
- Before troubleshooting, check that no spark jumps at the spark plug using a known good spark plug (to ensure that the plug does not cause the problem).
Moreover, check for proper spark plug gap and loose spark plug wire as well as for leakage of the ignition coil secondary current caused by moisture.
- If no spark jumps at one cylinder or one part of the ignition system on multi-cylinder engines, exchange the ignition coil with the other good one and perform the spark test. If good sparks jump, the exchanged ignition coil is faulty.
- As for peak voltage inspection, first measure the primary coil voltage of the ignition coil. If the voltage is abnormal, check each item in numerical order in the "Probable Cause" column described on the Troubleshooting chart.

IGNITION SYSTEMS

No spark at plugs (CDI, DC-CDI)

Unusual Condition		Probable Cause (Check in numerical order)
Ignition coil primary voltage	Low peak voltage.	<ol style="list-style-type: none"> ① Incorrect peak voltage adaptor connections. (system is normal if measured voltage is over the specifications with reverse connections.) ② The multimeter impedance is too low. ③ Cranking speed is too slow. <ul style="list-style-type: none"> • Battery is undercharged (or operating force of the kickstarter is weak). ④ The sample timing of the tester and measured pulse were not synchronized. (System is normal if measured voltage is over the standard voltage at least once.) ⑤ Poorly connected connectors or an open circuit in ignition system. ⑥ Faulty ignition system control circuit such as side stand switch or reverse switch circuit (for appropriate models only). ⑦ Faulty exciter coil. (Measure the peak voltage.) ⑧ Faulty ignition coil. ⑨ Faulty ignition control module (in case when above No. ①—⑧ are normal)
	No peak voltage.	<ol style="list-style-type: none"> ① Incorrect peak voltage adaptor connections. (system is normal if measured voltage is over the specifications with reverse connections.) ② Battery is undercharged. (Voltage drops largely when the engine is started—only for DC-CDI) ③ Short circuit in engine stop switch wire (except DC-CDI). ④ Faulty ignition switch or engine stop switch. ⑤ Loose or poorly connected ignition control module connector(s). ⑥ No voltage at the power source wire of the ignition control module (only for DC-CDI). ⑦ Open circuit or poor connection in ground cord of the ignition control module. ⑧ Faulty ignition system control circuit such as side stand switch or reverse switch circuit (for appropriate models only). ⑨ Faulty peak voltage adaptor. (See page 23-17 for inspection.) ⑩ Faulty exciter coil. (Measure peak voltage.) ⑪ Faulty ignition pulse generator. (Measure peak voltage) ⑫ Faulty ignition control module (in case when above No. ①—⑪ are normal).
	Peak voltage is normal, but no spark jumps at plug.	<ol style="list-style-type: none"> ① Faulty spark plug or leaking ignition coil secondary current ampere. ② Faulty ignition coil.
Exciter coil	Low peak voltage.	<ol style="list-style-type: none"> ① The multimeter impedance is too low. ② Cranking speed is too slow. <ul style="list-style-type: none"> • Battery is undercharged (or operating force of the kickstarter is weak). ③ The sample timing of the tester and measured pulse were not synchronized. (System is normal if measured voltage is over the specifications at least once.) ④ Faulty exciter coil (in case when above No. ①—③ are normal).
	No peak voltage.	<ol style="list-style-type: none"> ① Faulty peak voltage adaptor. (See page 23-17 for inspection.) ② Faulty exciter coil.
Ignition pulse generator	Low peak voltage.	<ol style="list-style-type: none"> ① The multimeter impedance is too low. ② Cranking speed is too slow. <ul style="list-style-type: none"> • Battery is undercharged (or operating force of the kickstarter is weak). ③ The sample timing of the tester and measured pulse were not synchronized. (System is normal if measured voltage is over the specifications at least once.) ④ Faulty ignition pulse generator (in case when above No. ①—③ are normal).
	No peak voltage.	<ol style="list-style-type: none"> ① Faulty peak voltage adaptor. (See page 23-17 for inspection.) ② Faulty ignition pulse generator.

No spark at plugs (Transistorized ignition system)

- "Initial voltage" of the ignition primary coil is the voltage measured with the ignition switch ON and engine stop switch at RUN (when the engine is not cranking with the starter motor).

Unusual condition		Probables cause (Check in numerical order)
Ignition coil primary voltage	No initial voltage with the ignition switch ON and engine stop switch at RUN. (Other electrical components are normal.)	① Faulty engine stop switch. ② Open circuit between the engine stop switch and ignition coil. ③ Loose or poor connection of the ignition coil primary wire terminal, or open circuit in primary coil. (Check at the ignition control module connector.) ④ Faulty ignition control module, in case when the initial voltage is normal with the ignition control module connector(s) disconnected.
	Initial voltage is normal, but it drops by 2 - 4 volts while cranking the engine.	① Incorrect peak voltage adaptor connections. ② Battery is undercharged. (Voltage drops largely when the engine is started.) ③ No voltage at the power source wire of the ignition control module, or loose or poorly connected ignition control module connector(s). ④ Poor connection or open circuit in ground wire of the ignition control module. ⑤ Loose or poor connections, or open circuit between the ignition coil and ignition control module. ⑥ Short circuit in ignition primary coil (except in case the coils are exchanged and checked on multi-cylinder engine). ⑦ Faulty ignition system control circuit such as side stand switch or reverse switch circuit (for appropriate models only). ⑧ Faulty ignition pulse generator. (Measure peak voltage.) ⑨ Faulty ignition control module (in case when above No. ① - ⑧ are normal).
	Initial voltage is normal, but no peak voltage exists while cranking the engine.	① Incorrect peak voltage adaptor connections. ② Faulty peak voltage adaptor. (See page 23-17 for inspection.) ③ Faulty ignition control module (in case when above No. ① and ② are normal).
	Initial voltage is normal, but peak voltage lower than the standard value.	① The multimeter impedance is too low. ② Cranking speed is too slow. • Battery is undercharged (or operating force of the kickstarter is weak). ③ The sample timing of the tester and measured pulse were not synchronized. (System is normal if measured voltage is over the specifications at least once.) ④ Faulty ignition coil (except in case the coils are exchanged and checked on multi-cylinder engine). ⑤ Faulty ignition control module (in case when above No. ① - ④ are normal, but no spark jumps at plug).
	Initial voltage and peak voltage are normal, but no spark jumps at plug.	① Faulty spark plug or leaking ignition coil secondary current ampere. ② Faulty ignition coil(s).
Ignition pulse generator	Peak voltage is lower than the standard value.	① The multimeter impedance is too low. ② Cranking speed is too slow. • Battery is undercharged (or operating force of the kickstarter is weak). ③ The sample timing of the tester and measured pulse were not synchronized. (System is normal if measured voltage is over the specifications at least once.) ④ Faulty ignition pulse generator (in case when above No. ① - ③ are normal).
	No peak voltage.	① Faulty peak voltage adaptor. (See page 23-17 for inspection.) ② Faulty ignition pulse generator.

SYSTEM DESCRIPTIONS

Most motorcycles use electrically controlled ignition systems. These ignition systems can be divided into CDI or transistorized types, depending on how they operate. Although their function is the same, the way they operate is different. In order to service these systems, one needs to understand their basic operation. Since both control their ignition-system components electrically, there is no mechanical wear, and periodic maintenance and adjustment are unnecessary.

CDI

The term CDI is an abbreviation for "Capacitive Discharge Ignition." The CDI produces quick and stable secondary voltage and is resistant to spark plug fouling. It is also designed to increase its secondary voltage as rpm increases.

Operating Principles

As the alternator rotor turns, current is induced in the alternator (exciter coil). This current (AC) is fed to the ignition control module with a voltage of 100–400 volts. This AC current is half-wave rectified by a diode and is stored in the capacitor inside the ignition control module.

When the engine is turned off, the current induced by the exciter coil is shorted to ground, thus cutting off current to the capacitor and turning off the spark.

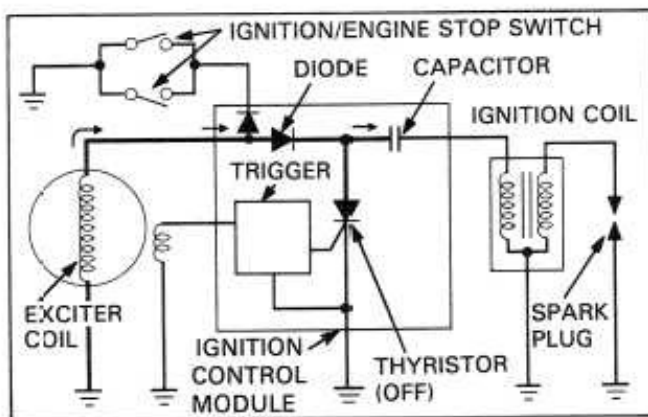

The capacitor cannot discharge until the SCR is turned ON. The SCR is turned ON as the ignition pulse generator sends pulses to the trigger circuit which, in turn, feeds current to the gate of SCR.

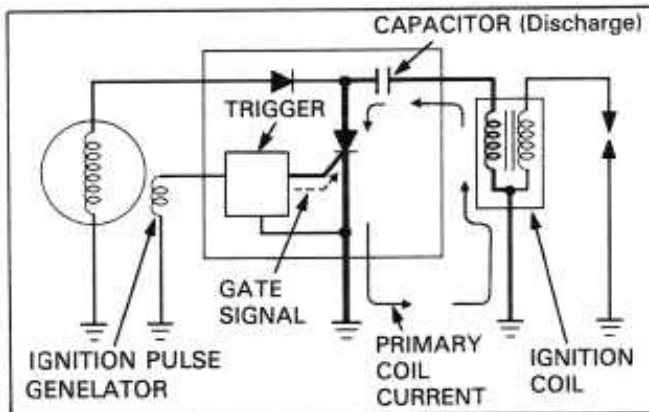

When the SCR is turned ON, the capacitor discharges current to the ignition primary coil. A high voltage surge induced in secondary coil jumps the spark plug gap.

NOTE

- This circuitry is also controlled by one additional circuit on models equipped with a side stand ignition cut-off system.

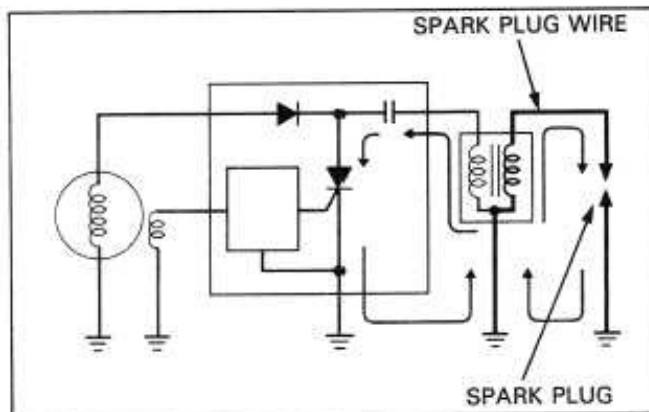

Principle of Ignition Timing Advance

Another function of the electrically controlled ignition system is that the ignition timing advance (or retard) is controlled electrically. This system requires no mechanical advance and has no mechanical wear. The overall design eliminates periodic adjustments and maintenance.

This section explains the operating principles of the ignition timing advance. The ignition timing retard system operates under the same principles.

The trigger circuit consists of a wave A and wave B generating circuit which converts the output from the ignition pulse generator to wave forms A and B, and an ignition timing selector circuit.

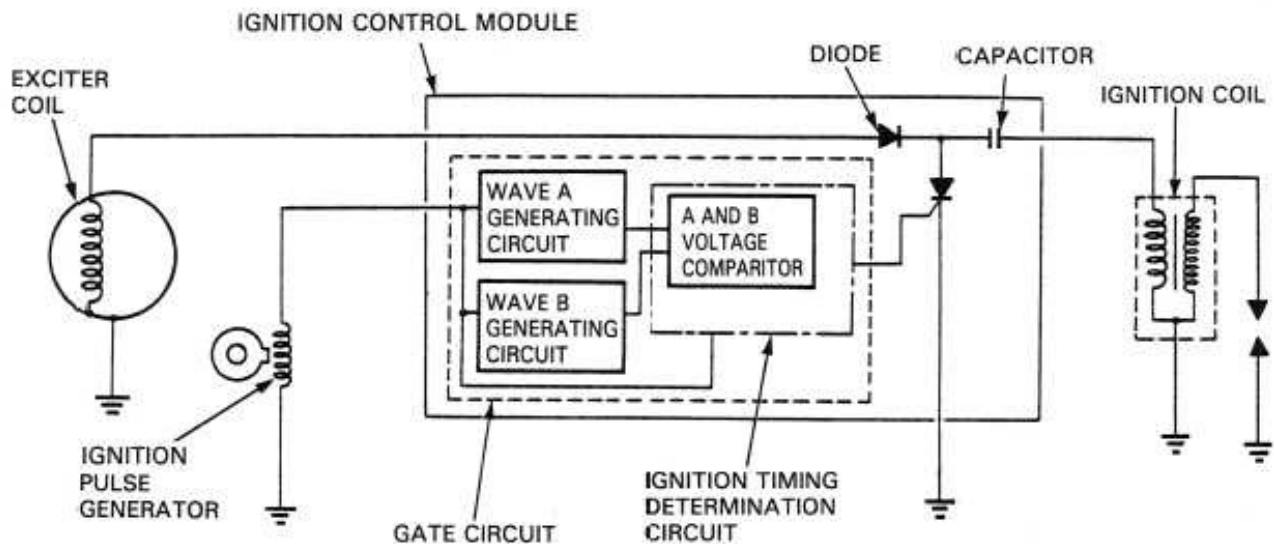

The ignition pulse generator produces positive and negative voltage pulses when the rotor reluctor crosses the generator.

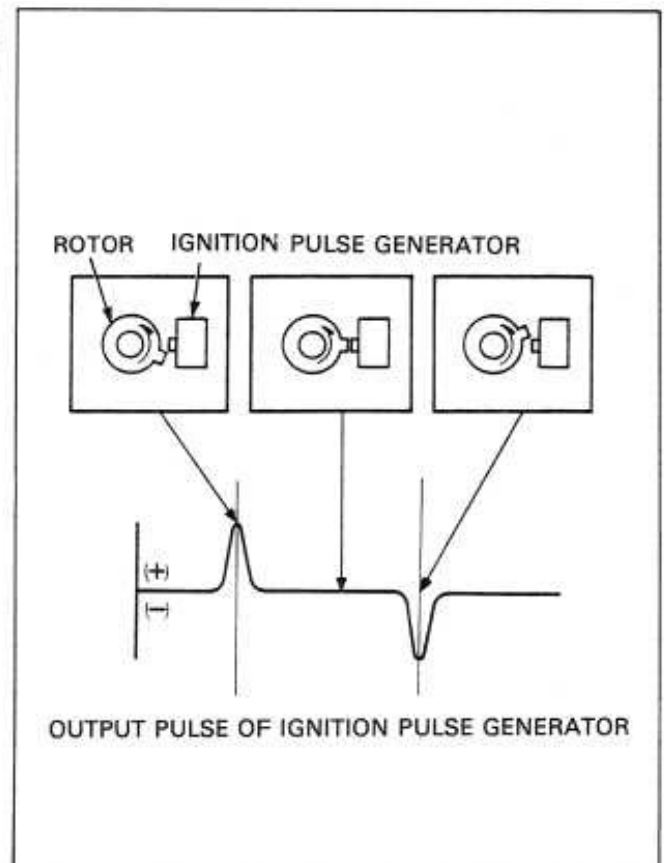

IGNITION SYSTEMS

The output from the ignition pulse generator is converted into basic waves A and B.

Basic wave A is unaffected by engine speed and remains constant.

Basic wave B changes its gradient as the engine speed increases as shown in the graph at right.

The ignition timing determination circuit sends current to the gate of the SCR when a negative voltage pulse from the ignition pulse generator is input to the determination circuit, or when wave A becomes greater than wave B. The current to the gate of the SCR turns it on and ignites the spark.

Since wave A remains constant and wave B changes its waveform as the engine rotation increases, wave B becomes smaller than wave A. As the engine speed increases, the timing at which wave A becomes greater than wave B advances. When the engine speed increases above N4, ignition timing no longer advances because basic wave A is not inclined.

At N1, wave B is larger than wave A and so ignition timing is determined by the negative voltage pulse from the ignition pulse generator.

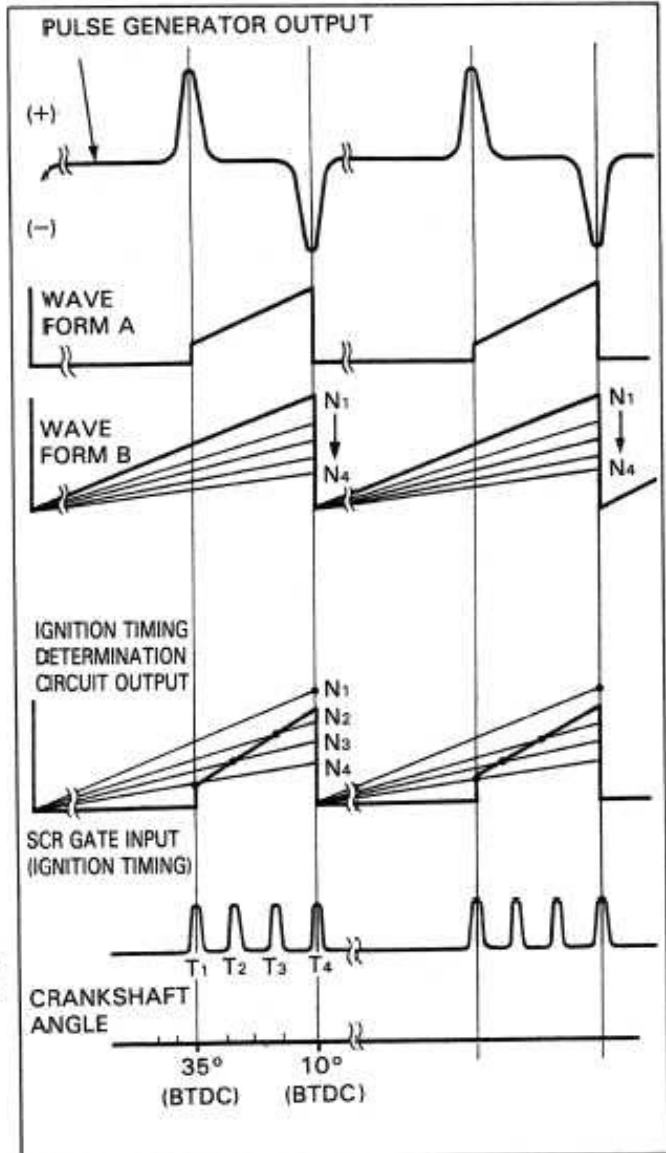

DC-CDI

The DC-CDI ignition system is basically a CDI system except that the battery is used for the source. The DC-CDI ignition control module includes a DC-DC converter which amplifies the battery voltage to about 220V, which is then stored in the capacitor. Except for the DC-DC converter, the DC-CDI ignition control module is identical to the CDI unit. Compared to conventional exciter coil-powered CDI, the DC-CDI provides greater spark energy at low rpm since the power source is stable battery energy.

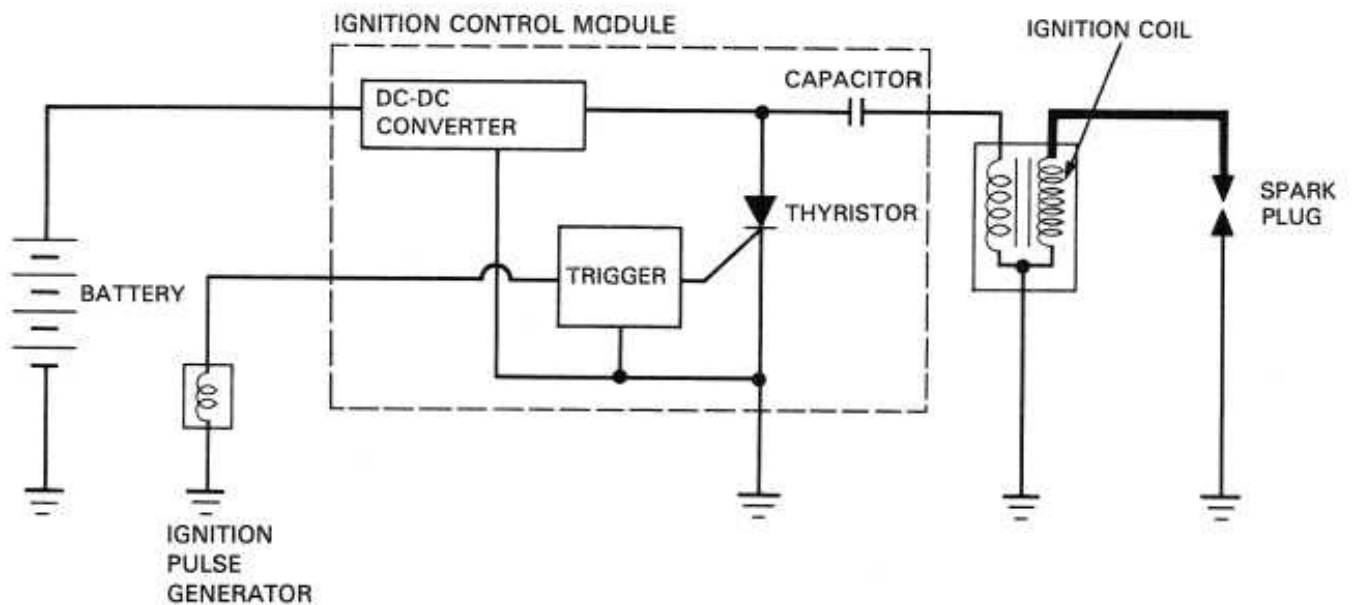

TRANSISTORIZED IGNITION SYSTEM

The transistorized ignition system also utilizes the battery, but its ignition operation works differently. Since the duration of time the spark plug fires is longer than that of a CDI system, the transistorized ignition system is well suited for large displacement engines.

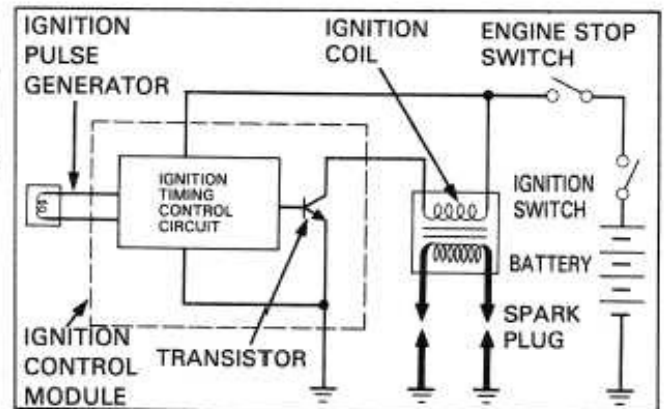

Operating Principles

The battery feeds current to the ignition primary coil via the ignition switch and the engine stop switch when the transistor inside the ignition control module is turned ON. This current is turned off when the transistor is OFF.

When the engine is turned on, the pulse signal from the ignition pulse generator is fed to the ignition timing control circuit. The ignition timing control circuit determines the ignition timing based on the pulse signal, and sends current to the base of the transistor.

After current pulse flows through the primary coil, the transistor is turned OFF and current to the coil is cut off. At that moment, an induced voltage on the secondary coil ignites the spark plugs.

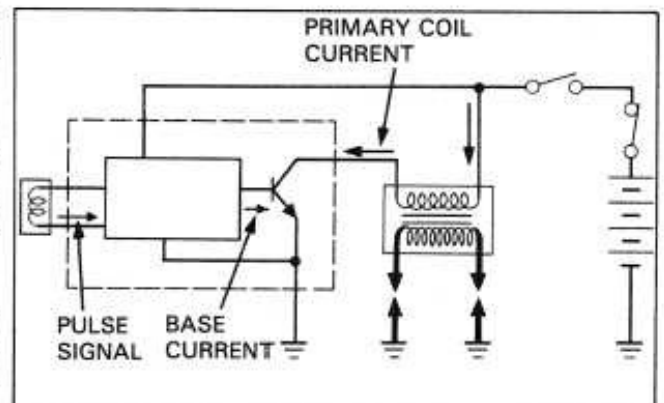

IGNITION SYSTEMS

As the engine speed increases, the duration of current flowing through the primary coil becomes shorter and eventually the secondary coil voltage is not high enough. The ignition timing control circuit also controls the duration of current flow through the ignition primary coil to ensure the correct plug-firing voltage to the secondary coil.

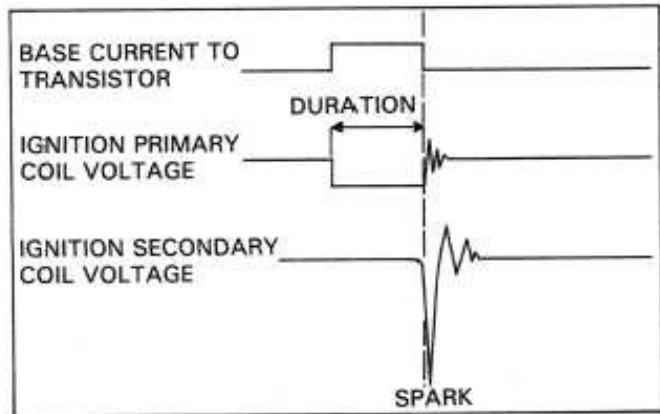

DIGITALLY CONTROLLED TRANSISTORIZED IGNITION SYSTEM

This system digitally controls the ignition timing using a microcomputer inside the ignition control module which calculates the ideal ignition timing at all engine speeds. The microcomputer also has a fail-safe mechanism which cuts off power to the ignition coil(s) in case the ignition timing becomes abnormal.

The system consists of an ignition pulse generator rotor, one or two ignition pulse generators, the ignition control module, ignition coil(s), and spark plug(s).

- 1) The ignition pulse generator rotor has projections called reluctors that rotate past the ignition pulse generator(s), producing electronic pulses which are sent to the ignition control module. The engine rpm and crankshaft position of each cylinder are detected by the relative positions of the projections of the ignition pulse generator rotor(s).
- 2) The ignition control module is non-serviceable and consists of a power distributor, a signal receiver, a microcomputer and a distributor.
 - The power distributor distributes battery voltage to the ignition control module when the key is turned on.
 - The signal receiver receives the electronic pulse from the ignition pulse generator(s) and then converts the pulse signals to a digital signal. The digital signal is sent to the microcomputer which has a memory and an arithmetic unit.
 - The microcomputer memory stores the desired characteristics of the timing for each rpm and crankshaft position. The arithmetic unit relays the rpm and crankshaft position to microcomputer memory. The memory then determines when to turn the transistor on and off to achieve the correct spark plug firing time.
 - When the transistor is turned on the primary coils of the ignition coils are saturated. Memory then turns the transistor off when it is time to fire the spark plug.

The system illustration below features a simplified single ignition pulse generator rotor system. This type is used on many models produced from early 1989 onward. Dual ignition pulse generator systems are very similar in design and are found on most engines produced before this time.

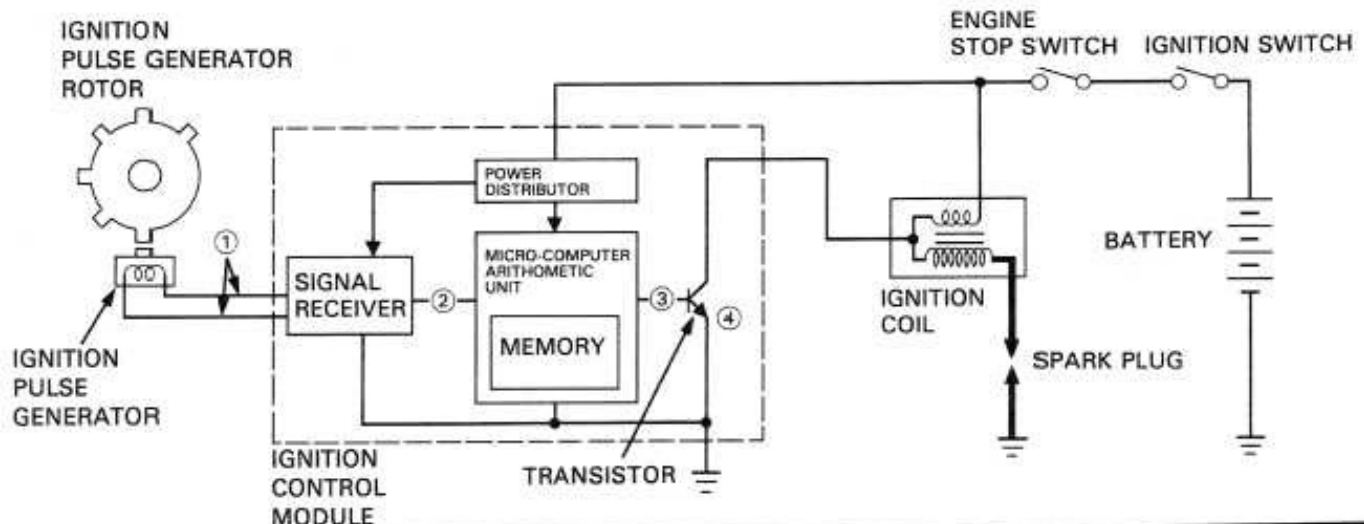

SPARK PLUG

Due to the high voltage generated at the ignition coil, sparks jump across the center electrode and side electrode of the spark plug and ignite the fuel mixture in the combustion chamber.

Use spark plugs of the proper size and heat range appropriate for the engine, or the engine will not perform to its full potential and damage to the engine may occur.

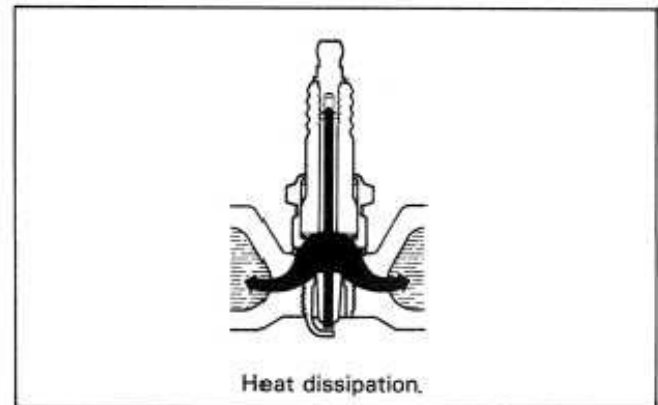

Spark plug heat range

As the spark plug is constantly exposed to the engine combustion, heat must be dissipated in order to keep the spark plug at a certain temperature at which carbon deposits are burned off.

The capacity to dissipate heat is called "heating value" or heat range.

It is important to install spark plugs of the proper heating value because the combustion temperature varies according to the engine type and driving conditions.

- Hot type.....Heat is dissipated slowly.
- Cold type.....Heat is dissipated quickly.
- The heating value indicated by a number:
 Smaller number.....Hotter type
 Larger number.....Colder type

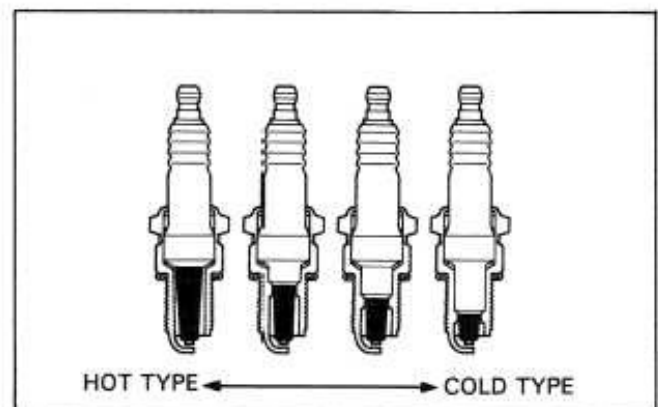

If an improper cold type spark plug is installed, the spark does not jump across the electrodes as easily and the electrodes may become contaminated with oil/gasoline. If an improper hot type is installed, it causes overheating or preignition, and may result in melted electrodes and/or a hole in the piston.

Optional spark plugs are often listed for Honda motor-cycles. Replace the standard plug with an optional one when-ever the heating value of the original plug does not comply with the driving conditions.

There are several types of spark plugs, grouped according to the heating value, thread diameter and construction, as shown below.

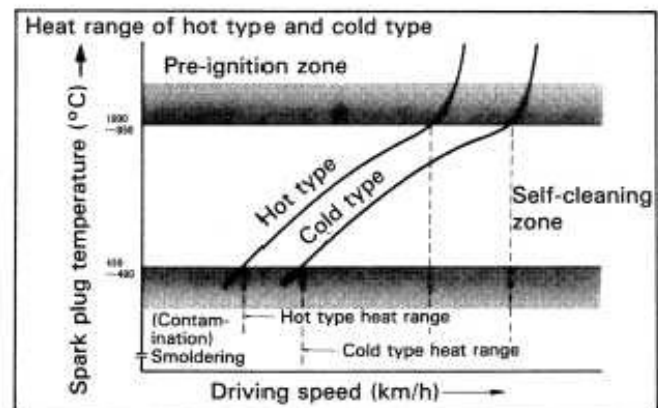

NGK plug

D	P	B	E	A-9
Thread dia.	Remark	Heating value	Thread length	Remark
A: 18 mm B: 14 mm C: 10 mm D: 12 mm	P: Porcelain projected type R: Resistor spark plug	4 (Hot type) 5 6 7 8 9 (Cold type)	E: 19 mm H: 12.7 mm	A, Z: Special type S: With copper wick V: Narrow center electrode K: Side electrode Number indicates the plug gap: "9": 0.9 mm

NIPPONDENSO plug

X	24	E	P	U	-9
Thread dia.	Heating value	Thread length	Remark	Remark	Remark
M: 18 mm W: 14 mm X: 12 mm U: 10 mm	14 (Hot type) 16 20 22 24 27 (Cold type)	E: 19 mm F: 12.7 mm	P: Porcelain projected type L: Special plug R: Resistor spark plug S: Porcelain not projected type U: With "U" groove in the side electrode	"9" indicates that the plug gap is 0.9 mm. If no number is listed, it usually indicates that the gap is 0.7 mm.	

IGNITION SYSTEMS

DESCRIPTION OF PEAK VOLTAGE ADAPTOR

The input or output voltage of the ignition system is a pulse voltage that increases and decreases within short periods of time. If an ordinary voltmeter was used to measure these kind of signals, it would read an incorrectly low voltage value. For example, the primary side pulse of the ignition coil reaches the range of some hundred volts for a moment whereas an ordinary voltmeter would read only millivolt values.

Rather than using an expensive oscilloscope which is suitable to measure such short-length pulses a much cheaper device is available to accurately measure peak voltages. This device is called a Peak Voltage Adaptor. In the U.S.A. the equivalent device is an Imrie 625 Ignition Analyzer.

Construction and Usage

The adaptor is an electrical circuit containing a diode, a capacitor, and a resistor. Pulse input signals supplied from test probes are rectified by the diode and used to charge the capacitor. In case of short intermittent pulse signals the voltage applied to the capacitor electrodes is almost similar to the peak voltage value. On the other hand, in case of long signal periods the capacitor voltage is slightly lower than the peak voltage.

The digital multimeter set to the DC range is able to measure this capacitor voltage.

In addition, by interchanging the positive and negative probes, the positive and negative peak voltage can be measured.

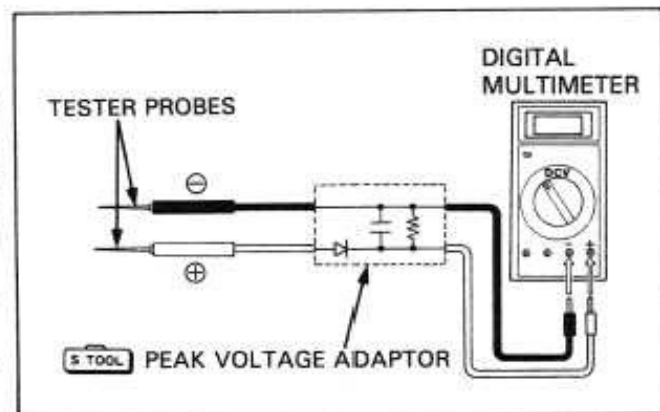
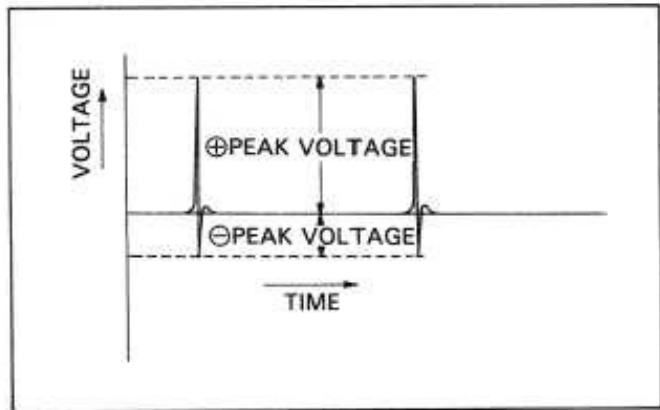

Operating Precautions

CAUTION

- Do not use the peak voltage adaptor to determine the ignition coil secondary voltage. The adaptor is designed only to measure voltages within the range of 0 to 630 V.
- As the capacitor gradually discharges via the resistor, the tester reading value will decrease accordingly. Therefore, only the highest value measured represents the true peak voltage.
- If a multimeter with a low input impedance is used, the discharge of the capacitor may be too fast for the peak voltage to be measured correctly. Be sure to use this adaptor together with commercially available digital multimeter (impedance 10M Ω /DCV minimum).
- When cranking the engine with kick starter, the cranking speed must be fast enough to produce a sufficient peak voltage. When using the starter motor, check with a fully charged battery.
- For models with a single cylinder and large displacement, the cranking speed is slow and, especially on the ignition pulse generator, the input pulses appear at long intervals. These input characteristics allow the capacitor voltage to drop causing the multimeter to measure voltage lower than actual peak voltage.

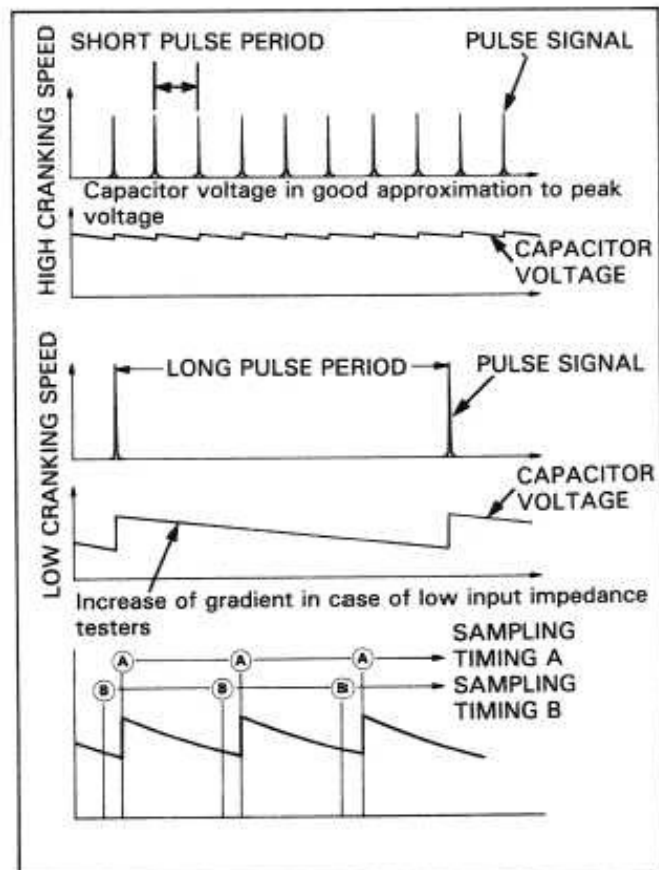

The sampling time of the multimeter (display switch-over time) is approximately 0.4 second. This amount of time may be almost similar to period of the pulses when cranking with a kickstarter.

Under this condition, because of the multimeter sampling time and the capacitor discharge timing, the peak voltage reading of the multimeter may be to low.

In case of the sampling time (A) shown in the figure, multimeter indicates a high peak voltage, and in case of (B), it indicates a low one. For this reason, measure the peak voltage several times in order to ensure a correct peak voltage reading.

SPARK TEST

Remove the spark plugs from the cylinder head and reconnect them to the plug caps.

Ground the spark plug to the cylinder head and turn the ignition ON. Avoid holding the spark plug to prevent electrical shock. Check if a good spark occurs while cranking the engine with the starter.

A high voltage spark will appear at the spark plug gap.

For multi-cylinder engines, remove the spark plug from each cylinder.

For some models with the CDI system, there is a circuit within the ignition control module designed to turn off the spark at low cranking speeds (below 200 - 500 rpm). In this case, leave the spark plug in the cylinder head and try the spark test with a known good spark plug.

Some ignition control module are designed to turn off the spark when the transmission is in gear or reverse position.

If the plug fires, the spark plug is good.

Note that spark plugs are more difficult to fire in dense air than under normal atmospheric conditions. Thus, even though a spark occurs under normal conditions, it may not occur in the compressed cylinder environment.

For this reason, you should check that the secondary coil has sufficient voltage by following the procedure that follows:

Attach a spark plug adaptor. Ground the black wire to the engine and conduct the spark plug test.

If there is a spark across the gap in the adaptor, the ignition coil is good.

TOOL:

SPARK ADAPTOR

07GGK-0010100
(Except USA)

If a spark occurs across the spark plug gap, but no spark occurs with the adaptor on, the secondary coil voltage is insufficient.

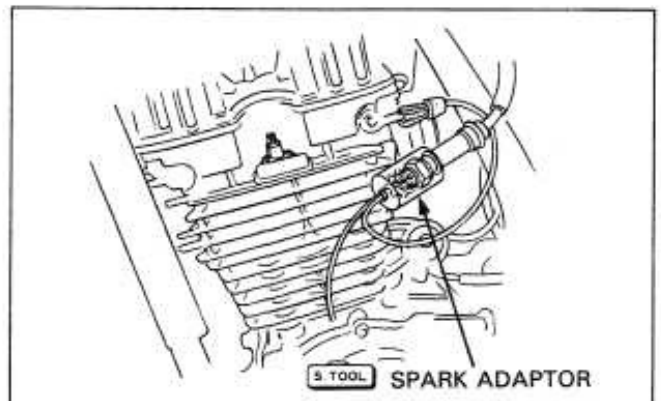
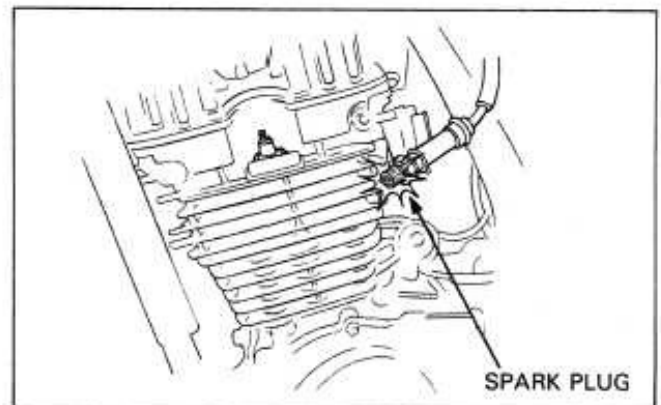

IGNITION SYSTEMS

IGNITION TIMING

Warm up the engine.

For models with multiple cylinders, connect a timing light to the No. 1 spark plug wire.

For models with no tachometer, connect an engine tachometer.

NOTE

- Read the manufacturer's instructions for the timing light and engine tachometer before operating.

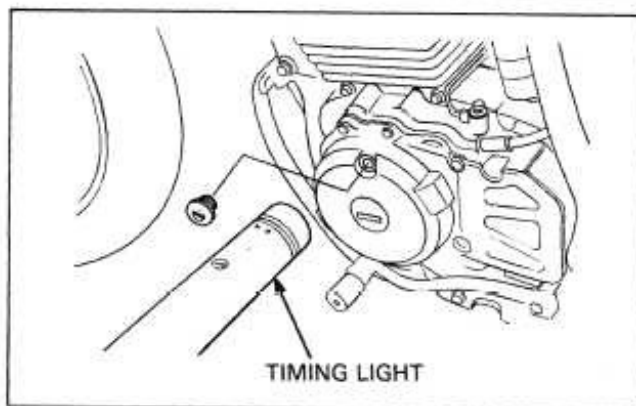

Remove the timing hole cap from the engine (refer to the Model Specific manual for the location of cap).

Start the engine and check for the following results:

- If the F mark on the rotor is aligned with the index mark on the case at the correct idling speed, then the timing is correct.
- Increase engine speed by rotating the stop screw on the carburetors.

Check if the F mark begins to move when the engine speed reaches the advance (or retard) start rpm. (This inspection cannot be done on models with a large ignition timing variation.)

- At full advance/retard rpm, the ignition timing is correct if the index mark is between the two advance/retard marks.

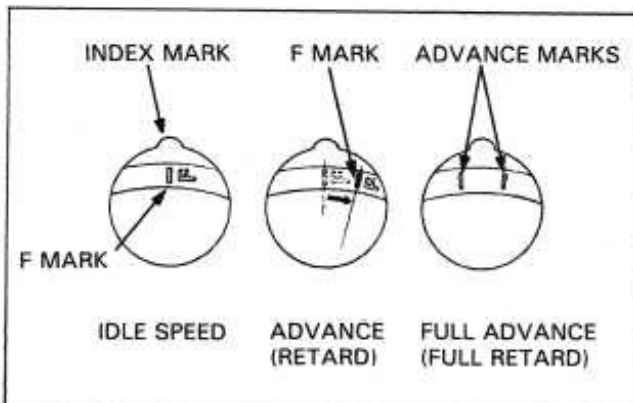

NOTE

- Because models with large ignition timing variations cannot be checked this way, there are no advance/retard marks on the rotor for these models. In that case, check only the F mark position.

Depending on the kind of timing light used when checking the ignition timing, you could detect abnormal advance timing.

This is because the spark plug wire being measured is not receiving a negative pulse. (Most timing lights are designed to receive negative pulses.)

If the spark plug wire being measured is receiving positive pulses, the input of the timing light will be receiving the alternated portion of the waveform and the timing light will flicker.

Reverse the inductive pick-up lead of the timing light, or, since the polarity of the waveform has no effect on the spark plug, connect the ignition primary coil wires to the opposite terminals. For double ignition coil types (a single coil firing two spark plugs), connect the timing light to the opposite wire of the same coil. The correct timing should then be observed.

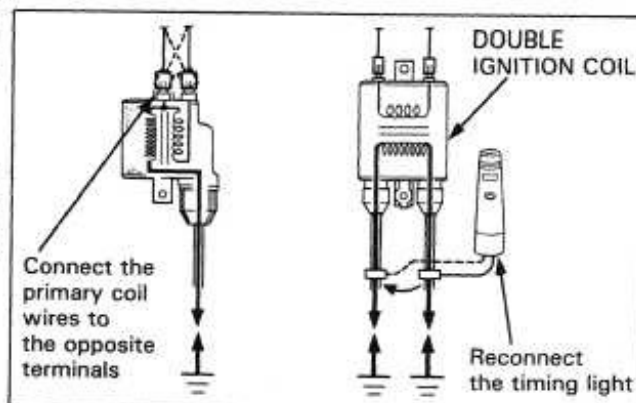
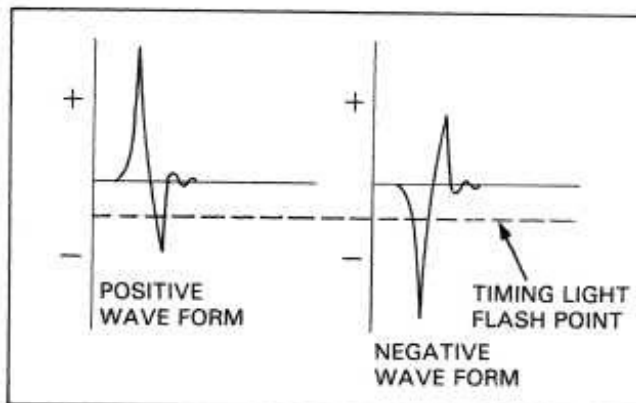

IGNITION SYSTEM INSPECTION (PEAK VOLTAGE MEASUREMENT METHOD)

NOTE

- If no spark jumps at the plug(s), check all connections for loose or poor contact before measuring each peak voltage.
- Use a commercially available digital multimeter (impedance 10M Ω /DCV minimum)
- The display value differs depending upon the internal impedance of the multimeter.
- If the Imrie diagnostic tester (Model 625) is used, follow the manufacture's instructions.

Connect the peak voltage adaptor to the digital multimeter.

TOOL :
PEAK VOLTAGE ADAPTOR 07HGJ-0020100 with commercially available digital multimeter or IMRIE DIAGNOSTIC TESTER (Model 625) in Australia.

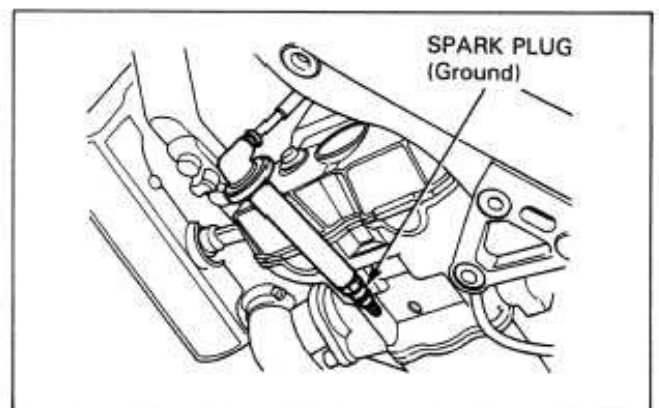
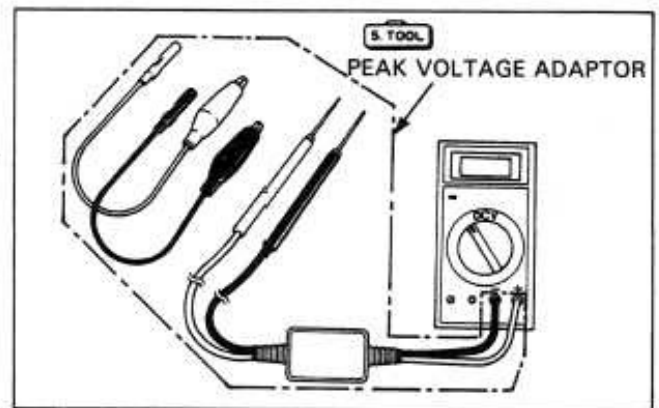

IGNITION COIL PRIMARY VOLTAGE INSPECTION

NOTE

- Check all system connections before this inspection. Poor connected connectors can cause incorrect readings.
- Make sure that the cylinder compression is normal and check with the spark plug and plug cap installed correctly. On the models with the transistorized ignition system, readings measured with the plug cap disconnected result in abnormally high peak voltage values.

In case of a multi-cylinder engine, the ignition caused by normal cylinder spark will result in an unstable cranking speed. In the same way as ordinary spark test, leave the spark plug installed in the cylinder head, install a known good spark plug into the plug cap and ground it to the engine.

When no spark jumps at plug and the engine does not start, however, the system can be checked with the spark plug and cap installed normally.

Connect the peak voltage adaptor between the ignition coil primary terminal that goes to the ignition control module (ICM) and a body ground with the connectors connected. Refer to the Model Specific manual for the connection of the adaptor (polarity).

NOTE

- If the peak voltage is lower than specifications, recheck peak voltage with reverse connection. The ignition system is normal if measured voltage is over the specifications with reverse connection.

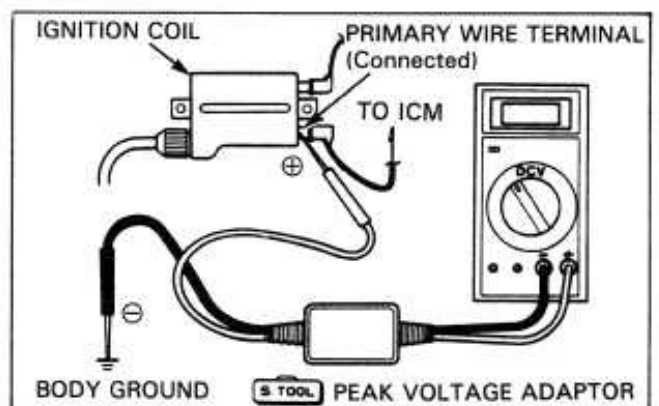

IGNITION SYSTEMS

Turn the ignition switch ON. If equipped with an engine stop switch, turn it to RUN position. In case of transistorized ignition system, then measure the voltage (initial voltage). If the tester indicates a value close to the battery voltage, the ignition coil power supply circuit is normal. If there is no voltage, the power supply circuit is defective. Check each item referring to the troubleshooting chart. Measure the peak voltage of the ignition coil primary side with the ignition switch ON and the engine stop switch to RUN position, while cranking the engine with the kick starter or starter motor. Refer to the Model Specific manual for the peak voltage value.

▲ WARNING

- To avoid possible electrical shock during voltage measurements, do not touch test probe metal parts.

NOTE

- If there are connectors between the ignition control module and the ignition coil, it is possible to check an open circuit or poorly connected connectors by comparing the peak voltage measured at every points. If no defects are found in the harness after checking it completely, the peak voltage is abnormal.
- In case of a configuration where several ignition coils are driven by one ignition control module, disconnected or loose connection in another ignition system circuit may cause abnormal voltage readings.
- On the models which use two or more ignition coils, various voltage may differ. As long as the measured voltages exceed the specified value, the system is normal.

EXCITER COIL

NOTE

- Install the spark plug(s) into the cylinder head and measure the peak voltage under normal cylinder compression.

Disconnect the connectors from the ignition control module (ICM) and connect the peak voltage adaptor probes to the exciter coil wire terminal of the harness side connector and ground.

Crank the engine with the kick starter or starter motor and measure the peak voltage of the exciter coil.

Refer to the Model Specific manual for the specified peak voltage and the connection of the adaptor probes.

▲ WARNING

- To avoid possible electrical shock during voltage measurements, do not touch the tester probe metal parts.

If the peak voltage measured at the ignition control module connector is abnormal, disconnect the nearest connector to the exciter coil and connect the adaptor probes to the exciter coil wire terminal and ground.

In the same way as at the ignition control module connector, recheck the peak voltage and compare it to the voltage measured at the ignition control module.

NOTE

- If the exciter coil wire is directly connected to the ignition control module, the test points will be on the same potential thus not allowing a value comparison.
- If there are connectors between the ignition control module and exciter coil, it is possible to check the wire harness for open circuit or loose connections by comparing the peak voltage measured at different points. If no defects are found in the harness after checking it completely, the peak voltage is abnormal.

- If the peak voltage measured at the ignition control module is abnormal and the one measured at the exciter coil is normal, the wire harness has an open circuit or loose connections.
- If both peak voltages measured are abnormal, check each item in the troubleshooting chart. If all items are normal, the exciter coil is faulty.

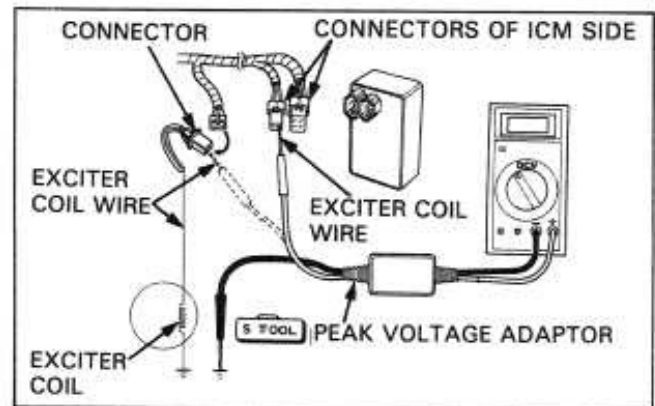

IGNITION SYSTEMS

IGNITION PULSE GENERATOR

NOTE

- Install the spark plug(s) into the cylinder head and measure the peak voltage under normal cylinder compression.

Disconnect the connectors from the ignition control module (ICM) and connect the peak voltage adaptor probes to the ignition pulse generator wire terminal of the wire harness side connector and ground. Crank the engine with the kick starter or starter motor and measure the peak voltage of the ignition pulse generator.

Refer to the Model Specific manual for the specified peak voltage and the connection of the adaptor probes.

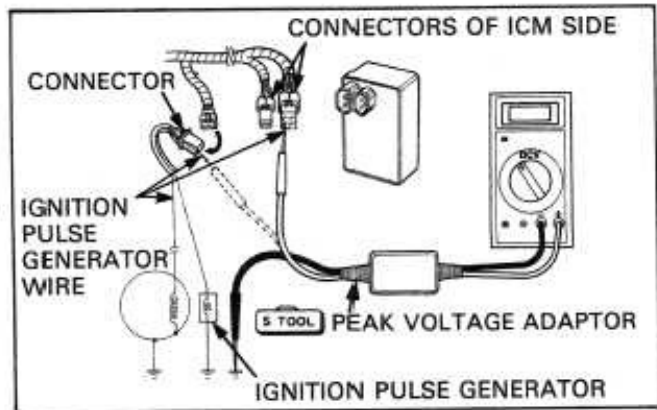

⚠ WARNING

- To avoid possible electrical shock during voltage measurements, do not touch the tester probe metal parts.

If the peak voltage measured at the unit connector is abnormal, disconnect the nearest connector to the ignition pulse generator and connect the adaptor probes to the ignition pulse generator wire terminal and ground.

In the same way as at the unit connector, recheck the peak voltage and compare it to the voltage measured at the ignition control module.

NOTE

- If the ignition pulse generator wire is directly connected to the ignition control module, the test points will be on the same potential thus not allowing a value comparison.
 - If there are connectors between the ignition control module and ignition pulse generator, it is possible to check the wire harness for open circuit or loose connections by comparing the peak voltage measured at different points. If no defects are found in the harness after checking it completely, the peak voltage is abnormal.
 - On the models equipped with two or more ignition pulse generator, various voltage may differ. As long as the measured voltages exceed the specified value, the system is normal.
-
- If the peak voltage measured at the ignition control module is abnormal and the one measured at the ignition pulse generator is normal, the wire harness has an open circuit or loose connections.
 - If both peak voltages measured are abnormal, check each item in the troubleshooting chart. If all items are normal, the ignition pulse generator is faulty.

PEAK VOLTAGE ADAPTOR INSPECTION

When testing the high tension on the ignition coil secondary side using the peak voltage adaptor, the inner diode may be damaged. As a damaged adaptor will cause incorrect peak voltage readings, always consider a defective adaptor if the peak voltage readings are all abnormal.

The adaptor diode can be easily checked by the following procedure. Therefore, be sure to check the adaptor before replacing the parts that display an abnormal testing value.

Set the multimeter to the AC voltage range and measure the local line voltage.

Then, connect the peak voltage adaptor to the multimeter, measure the same AC voltage with DC voltage range and compare it to AC voltage measured previously.

- The adaptor is normal if the DC voltage measured via the adaptor is 1.4 times of AC voltage.
- The adaptor is defective if the DC voltage measured via the adaptor is 0 V.

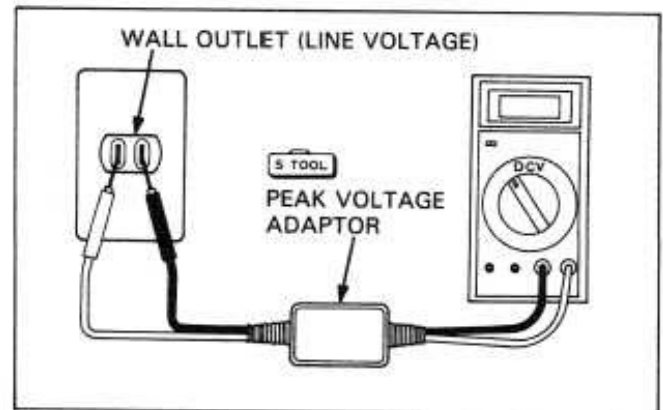

⚠ WARNING

- **If you touch the adaptor jack immediately after disconnecting the adaptor, you may get electrical shock. Be sure to disconnect the adaptor after allowing the voltage to decrease sufficiently.**

IGNITION COIL

NOTE

- Measure the peak voltage of the ignition coil primary side first.
- Since the resistance value of the primary coil is inherently very small, it is difficult to distinguish it from a shorted wire. Measure the coil resistance as a guideline for checking the coil.

PRIMARY COIL INSPECTION

Measure the resistance between the two terminals of the ignition primary coil.

If the resistance value is within the specified range, the coil is good.

If resistance is ∞ (infinite), replace the coil with a new one.

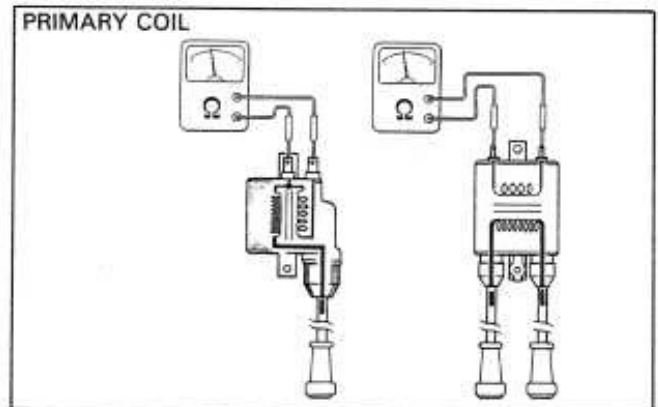

SECONDARY COIL INSPECTION

With the spark plug cap on, measure the resistance between the primary coil terminal and the spark plug cap.

For a double ignition coil, measure the resistance between the spark plug caps.

If the resistance value is within the specified range, then the coil is good.

If the resistance is ∞ (open wire), disconnect the spark plug cap(s) and measure the secondary coil resistance.

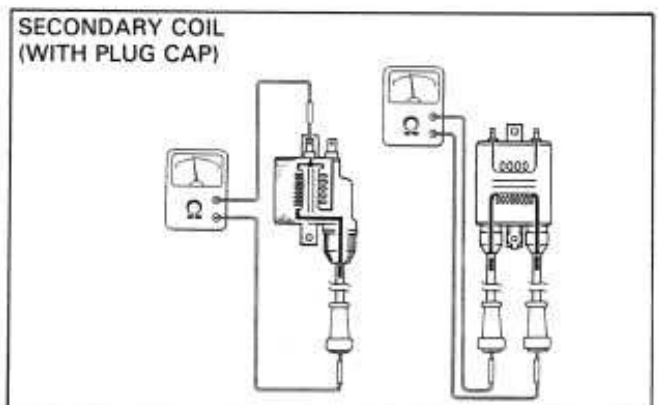

IGNITION SYSTEMS

Measure resistance between the primary coil terminal and the spark plug wire.

For a double ignition coil, measure the resistance between the spark plug wires,

If the resistance value is within the specified range, the coil is good.

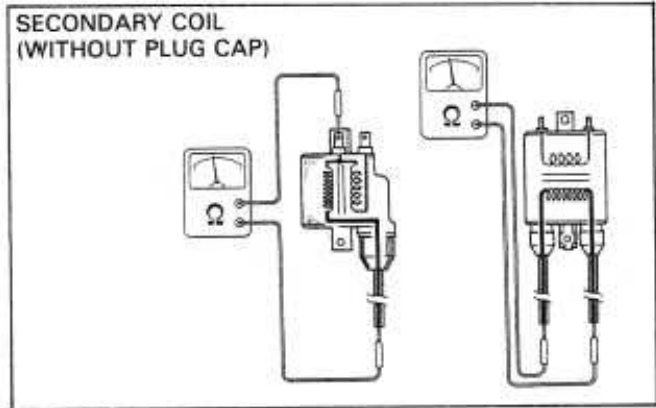



SIDE STAND IGNITION CUT-OFF SWITCH

DESCRIPTION

This device warns the rider that the side stand is lowered by turning on an indicator light. It also operates as an ignition cut-off switch when the transmission is shifted into gear, and prevents the starter motor and ignition from operating (and the battery from discharging) under certain conditions (described below).

OPERATING PRINCIPLE

"Starting" in the table below means "Starting the engine with the starter motor". Starting with the kick starter is excluded.

Side stand position	Transmission	Clutch lever	Ignition	Starting
Lowered 	Neutral	Pulled In	Possible	Possible
		Released	Possible	Possible
	In Gear	Pulled In	Not Possible	Not Possible
		Released	Not Possible	Not Possible
Retracted 	Neutral	Pulled In	Possible	Possible
		Released	Possible	Possible
	In Gear	Pulled In	Possible	Possible
		Released	Possible	Not Possible

TYPICAL COMPONENT LOCATIONS

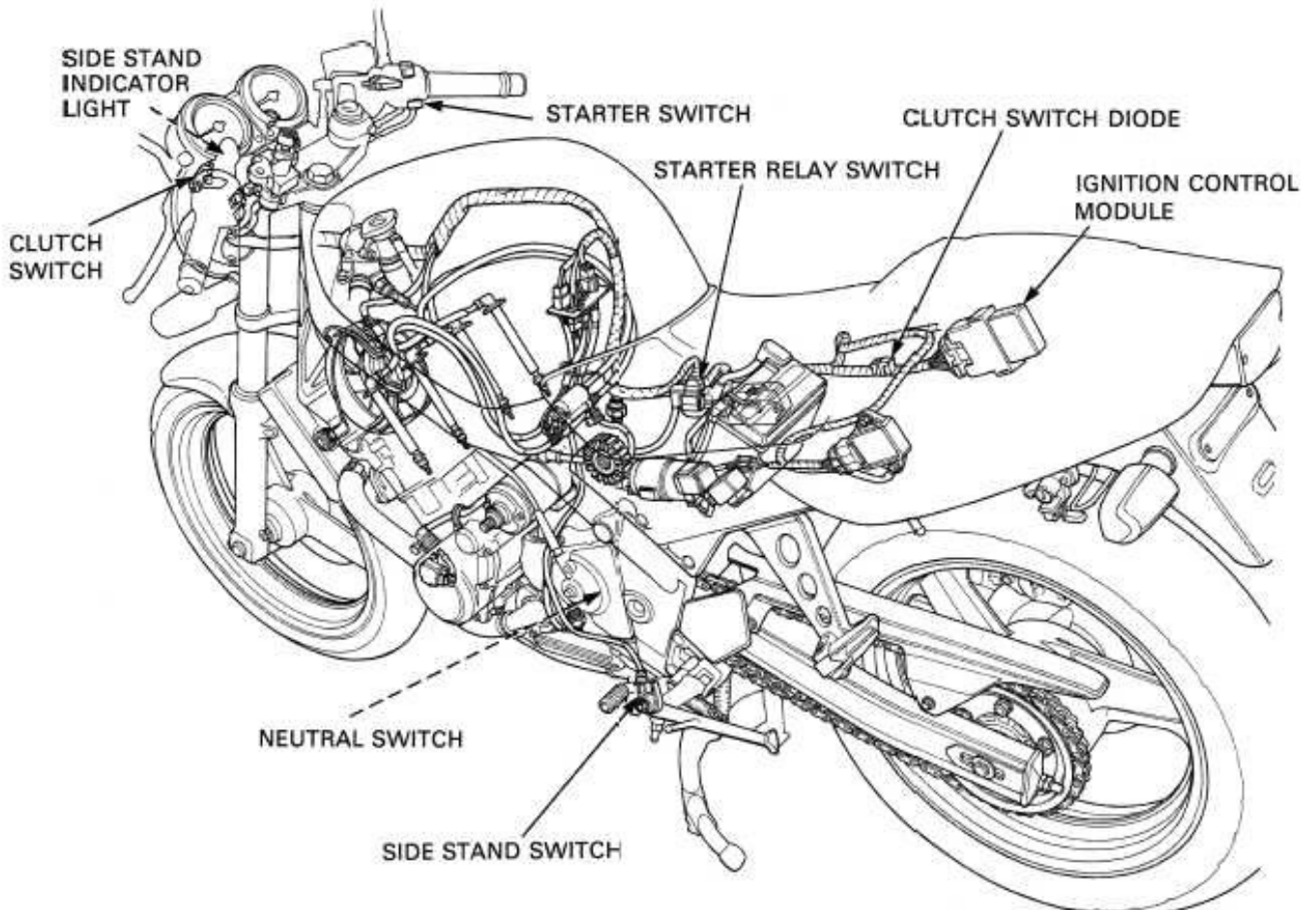

IGNITION SYSTEMS

COMPONENT FUNCTION

No.	Component	Function	Remarks
①	Indicator	When side stand is Lowered: Light ON Retracted: Light goes OFF	<ul style="list-style-type: none"> • Lens color is amber • "SIDE STAND" is described
②	Clutch switch	When clutch lever is Pulled In: ON (Continuity) Released: OFF (No continuity)	Same switch as of starting system
③	Starter switch	When starter switch is Pushed: ON (Continuity) Released: OFF (No continuity)	_____
④	Clutch switch diode	Prevents current from flowing in reverse direction	Also serves as a starting system diode
⑤	Ignition control module (ICM)	<ul style="list-style-type: none"> • Contains interface for side stand switch • When side stand switch wire is Grounded: Ignition is possible • Opened: Ignition is not possible 	Circuits are different depending on ignition system
⑥	Starter relay switch	When relay coil in the switch is Activated: Starter motor turns Not Activated: Motor stops	Same as ordinary starter relay switch
⑦	Side stand switch	When side stand is Lowered: Contact point of ignition/ starting side is open Contact point of indicator side is closed Retracted: Contact point of ignition/starting side is closed Contact point of indicator side is open	<ul style="list-style-type: none"> • Installed on the side stand pivot bolt • Refer to next page for operation

SIDE STAND SWITCH OPERATION

The side stand switch detects the side stand position electrically. The switch is installed on the side stand pivot bolt. On some models, the switch is installed on the rear of the pivot bolt or is covered.

The switch is a rotary-type and the fixed contact is set to the frame. The rotary switch contact rotates inside the switch housing following the movements of the side stand.

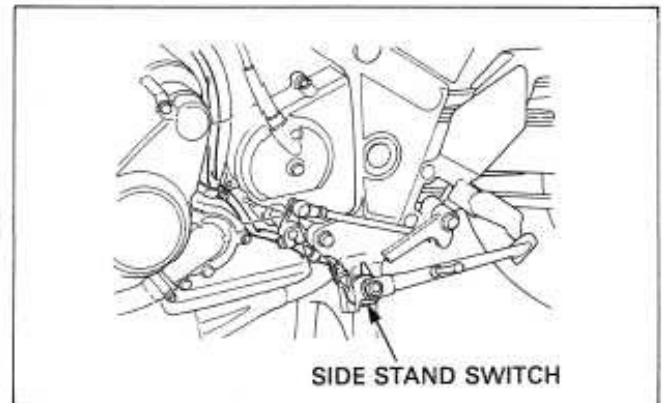

The side stand switch is activated by the side stand position, as shown below.

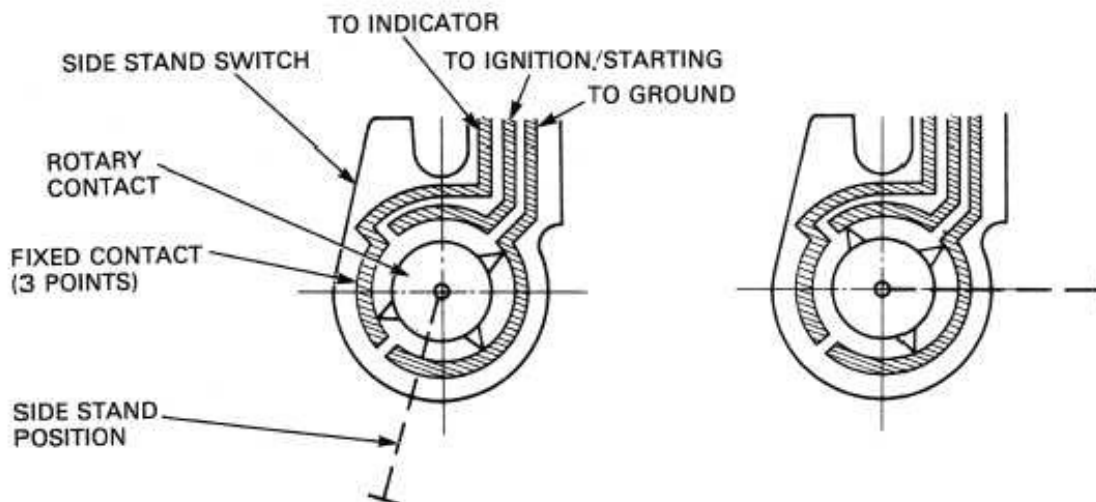
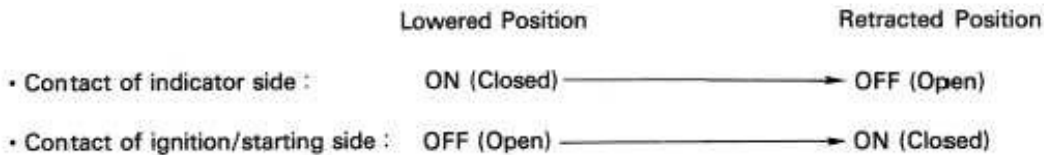

INDICATOR OPERATION

When the side stand is lowered, the indicator contact of the side stand switch is connected to ground and battery current flows through the circuit to light the indicator.

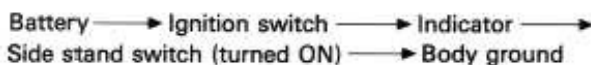

When the side stand is retracted, the indicator contact of the side stand switch is open. Therefore, current from the battery cannot flow and the indicator light goes off.

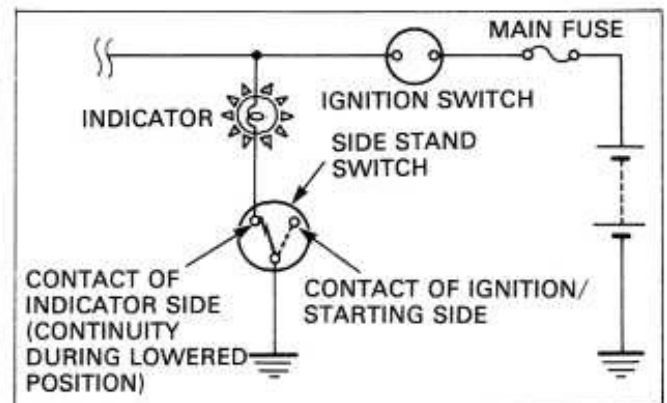

IGNITION SYSTEMS

STARTING SYSTEM (STARTER MOTOR) OPERATION

Model With Manual Clutch

When the ignition switch is turned ON and the starter switch is pushed, battery voltage is applied to the starter relay switch coil. If the switches in the ground circuit of the starter relay switch are not turned ON (condition (a) or (b) below), the circuit cannot be grounded and the starter motor does not operate.

- (a) Neutral switch is turned ON
- (b) Both clutch and side stand switches are turned ON

If either condition (a) or (b) (above) is met, current from the battery flows through the circuit as shown in the diagram at right, the starter relay switch is turned ON and the starter motor operates.

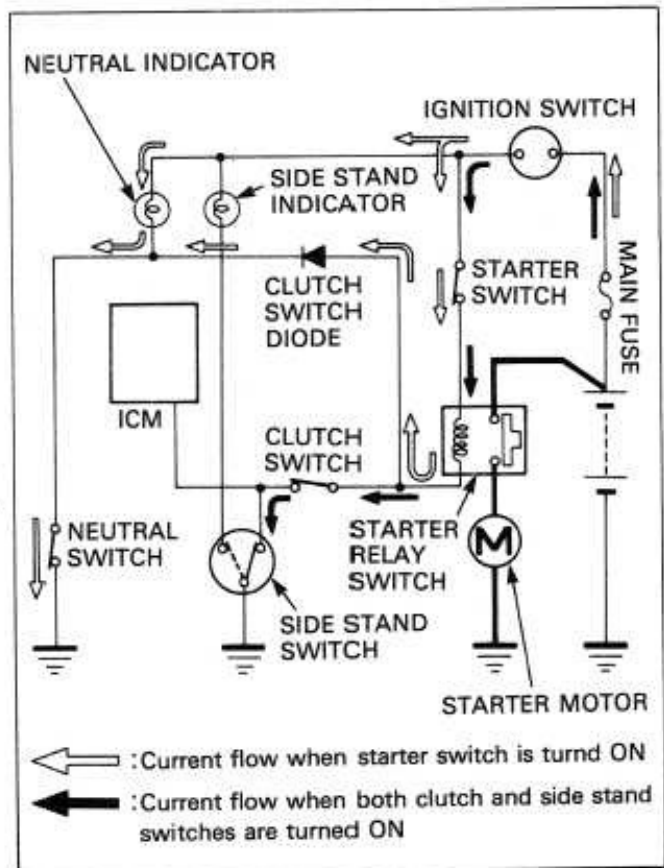

Model With Centrifugal Clutch

To prevent vehicles with a centrifugal clutch from lurching forward when the engine starts, a circuit is used that prevents voltage from reaching the starter relay switch unless the brake is applied (brake light switch is turned on).

The side stand switch is part of the ground circuit. Only when the side stand is retracted is the ground circuit complete and the starter motor able to operate.

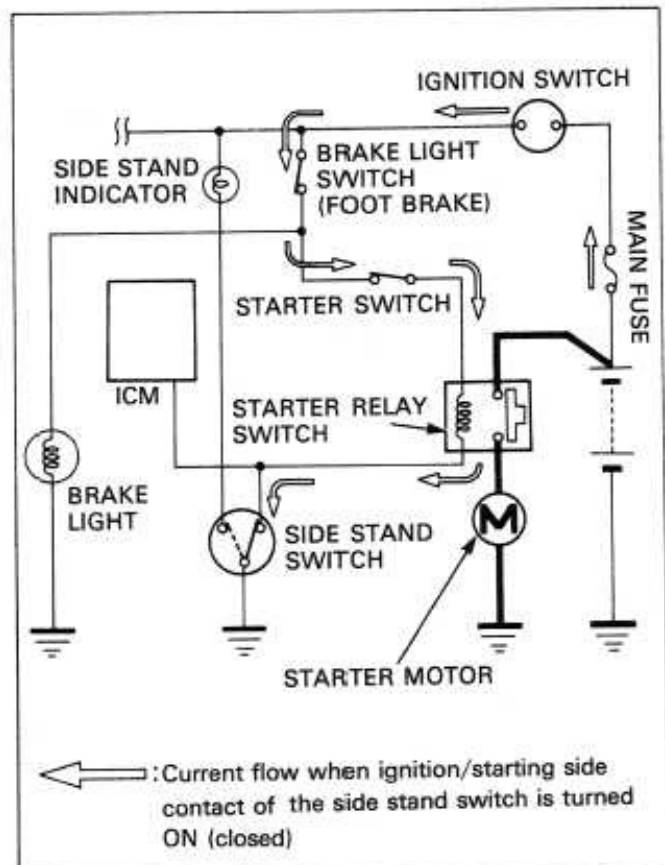

IGNITION SYSTEM OPERATION

CDI System Integrated With Side Stand Switch And/Or Neutral Switch

CDI Systems integrated with a side stand switch and a neutral switch operate similar to other CDI systems except that the ignition control module also controls the circumstances that allow ignition through an interface and transistor.

The interface determines whether to turn the transistor on or off.

The transistor determines how the ignition control circuit works by turning the SCR (thyristor) on or off.

The interface receives information through the external detection circuit consisting of the side stand and neutral switches. A diode in this circuit prevents current from flowing in the reverse direction. This circuit must have a ground path for ignition to be possible.

Ignition is not possible if both of the following conditions occur:

- (a) side stand is lowered
- (b) transmission is in gear

Models without transmissions, (such as scooters), do not have neutral switch or clutch circuits and therefore condition (b) does not apply.

Example Of A Circuit For Models With Manual Cluth/Transmission

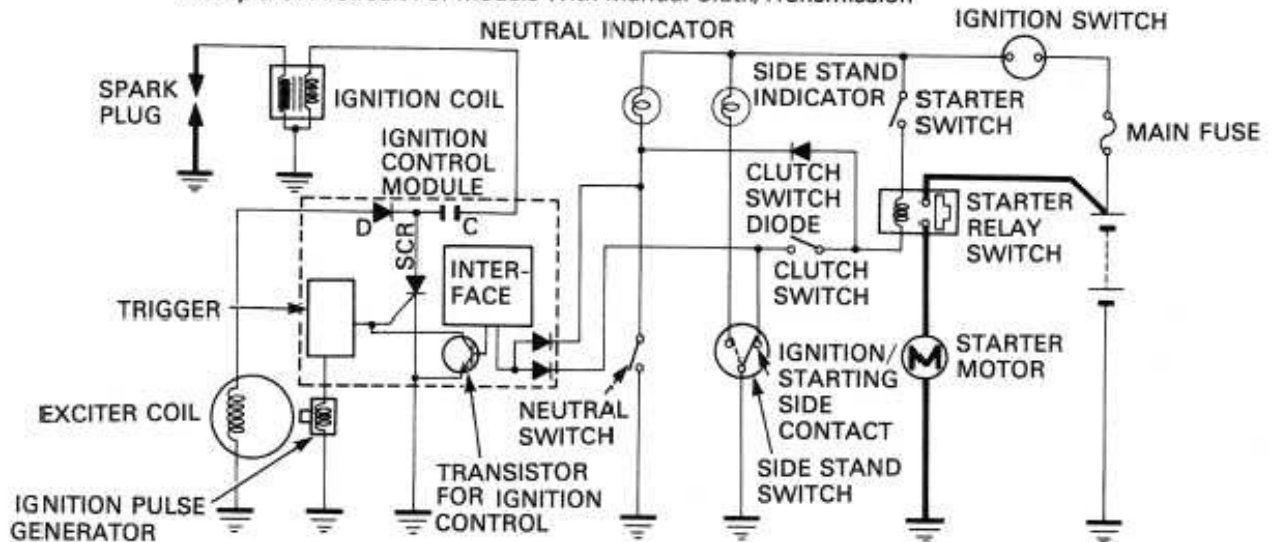

Under conditions (a) and (b), the interface in the ignition control module is activated and sends the base signal to the transistor and the transistor is turned ON.

When the transistor is turned ON, it conducts the gate signal from the trigger to ground. Therefore, the SCR (thyristor) cannot be turned on and the ignition is not possible.

Ignition Is Not Possible

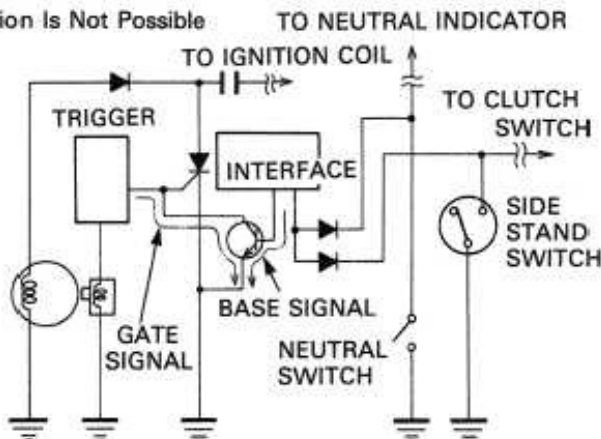

When :

- the side stand is retracted and
 - the transmission is placed in neutral
- the transistor is turned OFF as the interface is deactivated. Therefore, the gate signal from the trigger can be applied to the SCR and ignition is possible.

Ignition Is Possible

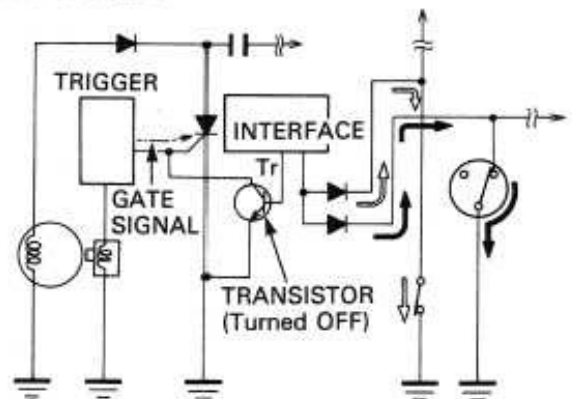

IGNITION SYSTEMS

DC-CDI Systems Integrated With Side Stand Switch And/Or Neutral Switch

DC-CDI Systems integrated with a side stand switch and a neutral switch operate similar to other DC-CDI systems except that the ignition control module (DC-CDI unit) also controls the circumstances that allow ignition through a resistor and a transistor.

The external detection circuit similar to the system described previously, but the method of ignition control is different.

The resistor determines whether the transistor is turned off or turned on. The transistor determines how the ignition control circuit works by activating or deactivating the DC-DC converter.

If the transistor is turned off, the DC-DC converter is activated to make ignition possible.

The resistor receives information through the external detection circuit consisting of the side stand and neutral switches. A diode in this circuit must have a ground path to make ignition possible.

Ignition is not possible if both of the following conditions occur:

- (a) side stand is lowered
- (b) transmission is in gear

Models without transmissions, (such as scooters), do not have neutral switch or clutch circuits and therefore condition (b) does not apply.

Example Of A Circuit For Models With Manual Clutch/Transmission

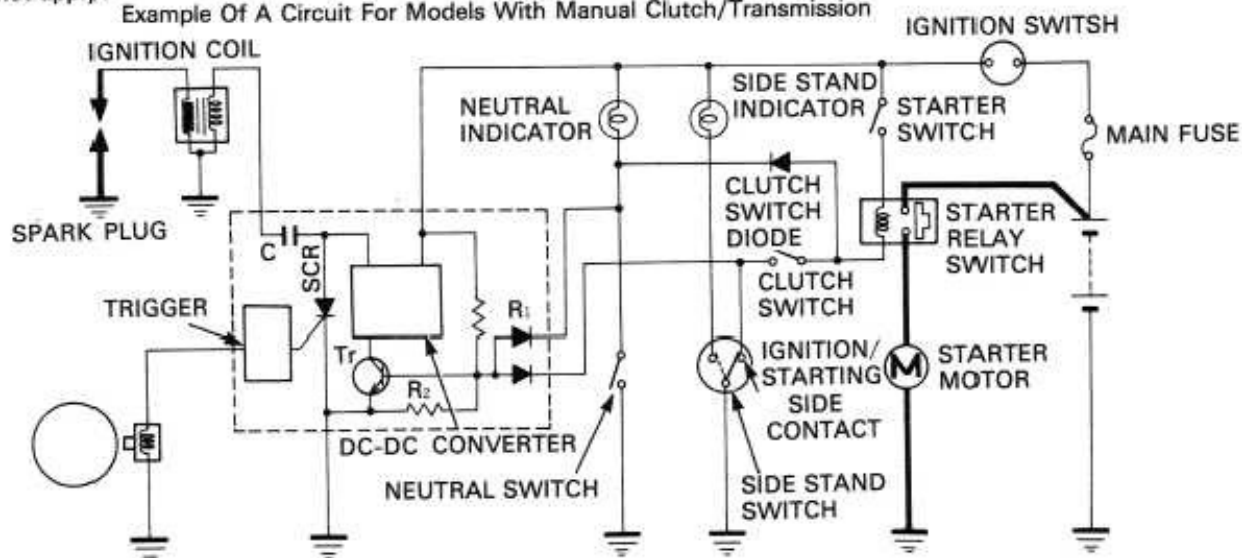

Under conditions (a) and (b), the signal from the DC-DC converter is applied to the transistor through the resistor, turning the transistor ON. When the transistor is turned ON, the signal from the DC-DC converter is deactivated. This means that no electrical current from the DC-DC converter is applied to the capacitor, and ignition is not possible.

When:

- the side stand is retracted and
- the transmission is placed in neutral

the signal from the DC-DC converter is grounded through the side stand and the neutral switches. The signal is not applied to the transistor, and therefore the transistor is turned OFF. When the transistor is turned OFF, the signal from the DC-DC converter is activated and, therefore, applied to the capacitor to make ignition possible.

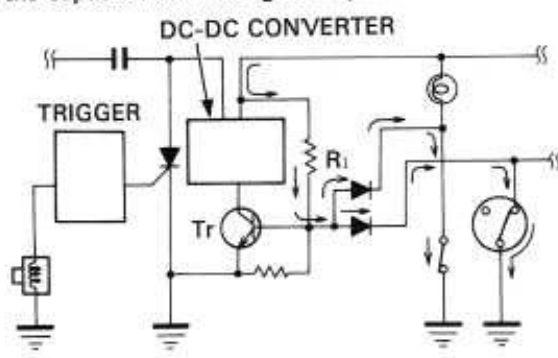
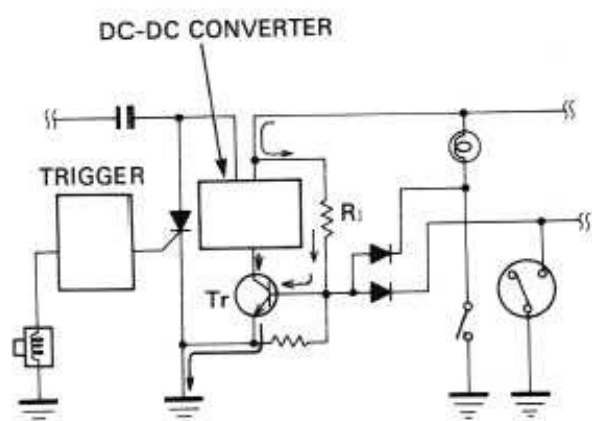

Transistorized Ignition System Integrated With Side Stand Switch And Neutral Switch

Transistorized Ignition Systems (TPI) integrated with a side stand switch and neutral switch operate similar to other TPI systems except that the TPI unit also controls the circumstances that allow ignition through a resistor and a transistor.

The ignition control circuit in the ignition control module is deactivated in the same way as the DC-CDI ignition system.

Under condition (a) and (b): if the sidestand is lowered and the transmission is placed in gear, the signal from the ignition control module power supply line is applied to the transistor through the resistor to turn the transistor ON. When the transistor is turned ON, the signal from the ignition control module power supply line is deactivated. This means that no electrical current from the ignition control module power supply line is applied to TR2 (power transistor) and ignition is not possible.

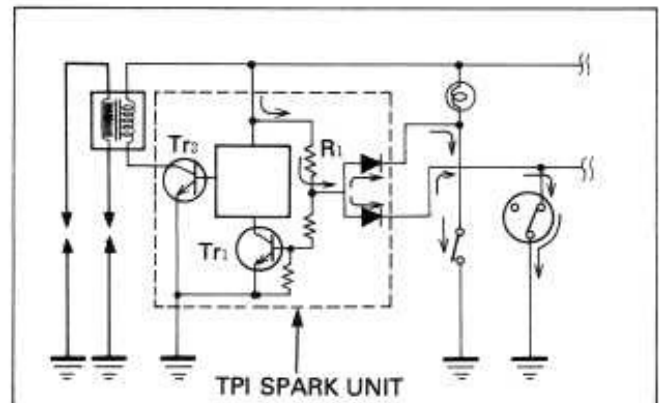

MEMO

24. ELECTRIC STARTER/STARTER CLUTCH



SERVICE INFORMATION	24-1	CLUTCH SWITCH DIODE INSPECTION	24-8
TROUBLESHOOTING	24-1	STARTER CLUTCH INSPECTION	24-8
STARTER MOTOR	24-3	STARTER PINION INSPECTION	24-9
STARTER RELAY SWITCH	24-6		

SERVICE INFORMATION

▲ WARNING

- Always turn the ignition switch OFF before servicing the starter motor. The motor could suddenly start, causing serious injury.

- Refer to the Model Specific manual for removal and installation of the starter motor.
- A weak battery may be unable to turn the starter motor quickly enough, or, supply adequate ignition current.
- The starter motor may be damaged if current is allowed to flow to it when the engine cannot turn over.
- For models with a centrifugal clutch, incorrect adjustment of the brake light switch could prevent the starter motor from operating.
- Refer to section 25 for the side stand switch and indicator inspections.
- The starter motor will not operate unless the conditions under which the engine can be started are met on models with the side stand ignition cut-off switch.
- Refer to section 23 for the description and operation of the side stand ignition cut-off switch.
The following table describes the conditions when the engine can or cannot be started. "Not possible" in the "Starting" column means that the starter motor cannot be operated.

Side stand position	Transmission	Clutch lever	Ignition	Starting
Lowered 	Neutral	Pulled In	Possible	Possible
		Released	Possible	Possible
	In Gear	Pulled In	Not Possible	Not Possible
		Released	Not Possible	Not Possible
Retracted 	Neutral	Pulled In	Possible	Possible
		Released	Possible	Possible
	In Gear	Pulled In	Possible	Possible
		Released	Possible	Not Possible

TROUBLESHOOTING

Starter motor turns slowly

- Low specific gravity in battery (or Dead battery)
- Poorly connected battery terminal
- Poorly connected starter motor cable
- Faulty starter motor
- Poorly connected battery ground cable

Starter motor relay "clicks," but engine does not turn over

- Crankshaft not turning due to engine problems
- Excessive reduction gear friction
- Faulty starter pinion engagement

Starter motor turns, but engine does not turn

- Starter motor is running backwards
 - Brushes assembled improperly
 - Case assembled improperly
 - Terminals connected improperly
- Faulty starter clutch
- Damaged or faulty starter pinion
- Damaged idler gear or reduction gear
- Broken starter motor drive chain
- Faulty starter clutch

ELECTRIC STARTER/STARTER CLUTCH

Starter motor will not turn.

- Check for a burnt main or sub fuse before servicing.
- For models with a centrifugal clutch, check that the brake light switch is correctly adjusted.
- Check that the side stand is positioned and/or transmission is placed in the conditions under which the engine can be started on models which employ the side stand ignition cut-off switch.

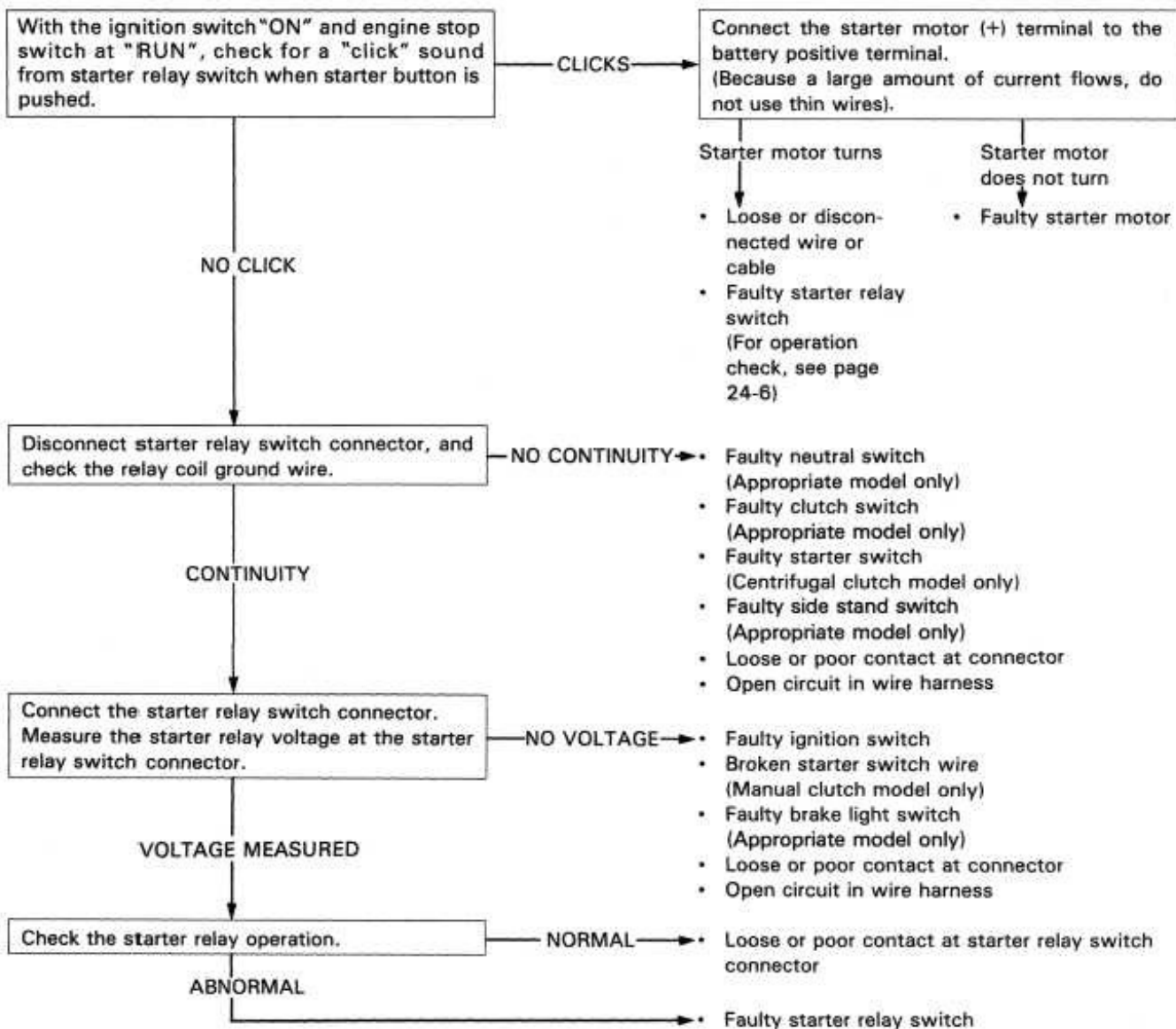

STARTER MOTOR

DISASSEMBLY

Before disassembling the starter motor, mark the index lines on the case and covers so the starter can be assembled correctly later.

Remove the starter motor case screws and remove the covers.

NOTE

- For models with shims between the armature and cover, record the location and number of shims and their order so the parts can be installed correctly later.

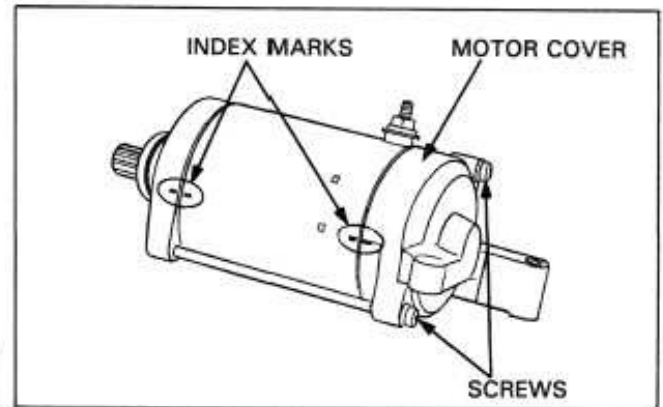

INSPECTION

Check for continuity of the starter motor case.

- Between the cable terminal and the case. There should be no continuity.
- Between the cable terminal and the brush (black wire). There should be continuity.

If the readings are abnormal, replace the case with a new one.

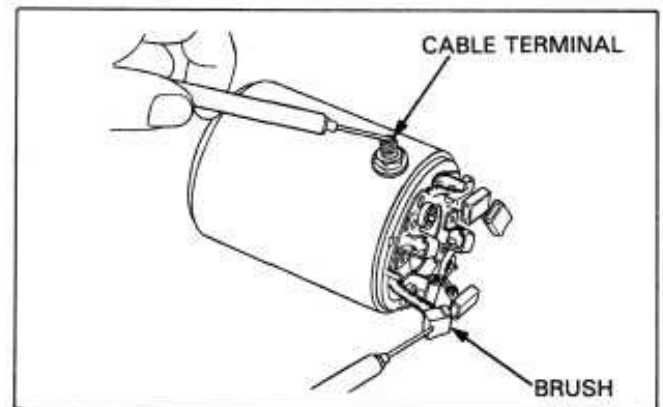

Measure the brush length.

Replace the brush if it is worn beyond the service limit specified in the Model Specific manual.

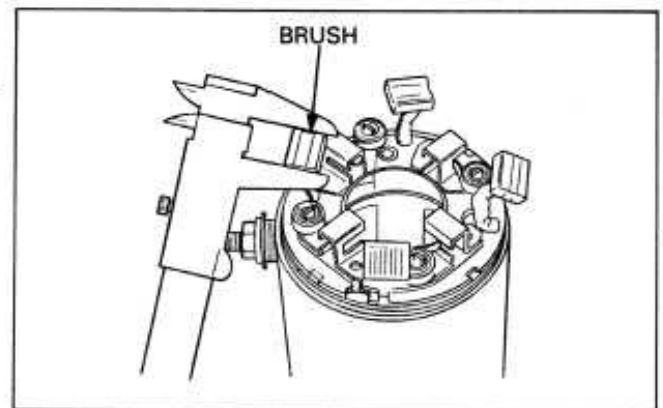

Check for continuity between the ⊕ and ⊖ terminals of the brush holder.

If there is continuity, replace the holder with a new one.

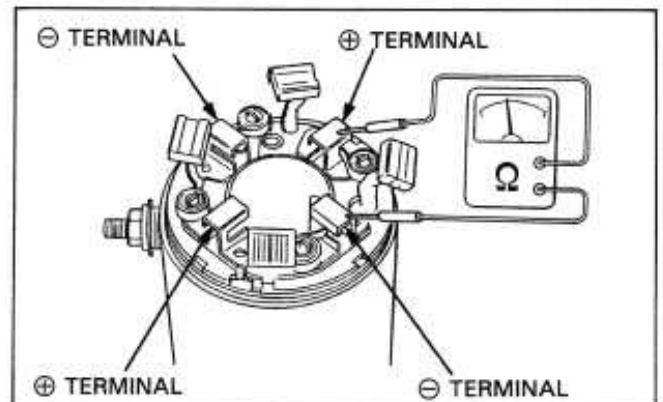

ELECTRIC STARTER/STARTER CLUTCH

Check the commutator for:

- Damage or abnormal wear
- Discoloration of the commutator bar
- Replace the commutator if it is damaged or discolored .
- Check for and remove any metallic debris from between commutator bars

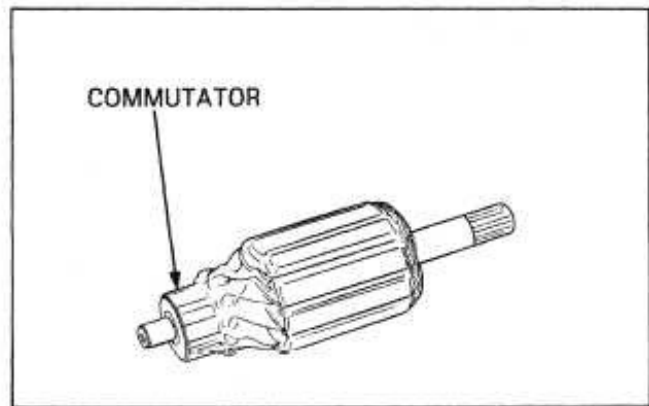

Check for continuity between pairs of commutator bars.

Make a continuity check between individual commutator bars and the armature shaft.

There should be no continuity.

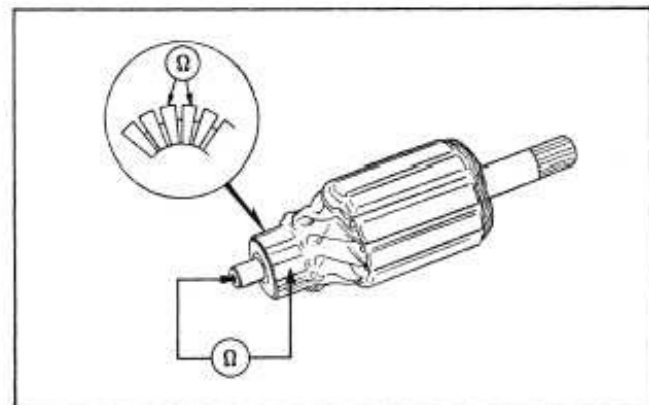

Check the bearings. (For applicable models only.)

If the bearings are loose or noisy, or if they do not turn smoothly, replace the cover.

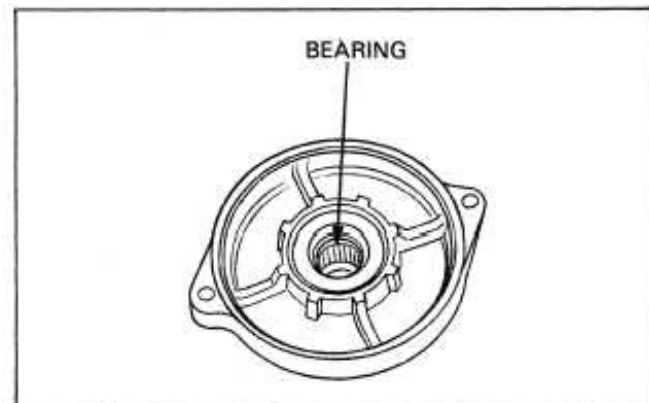

ASSEMBLY

Align the case notch with the brush holder pin and install the holder on the case.

Place the O-ring (seal ring) on the case. (For applicable models only.)

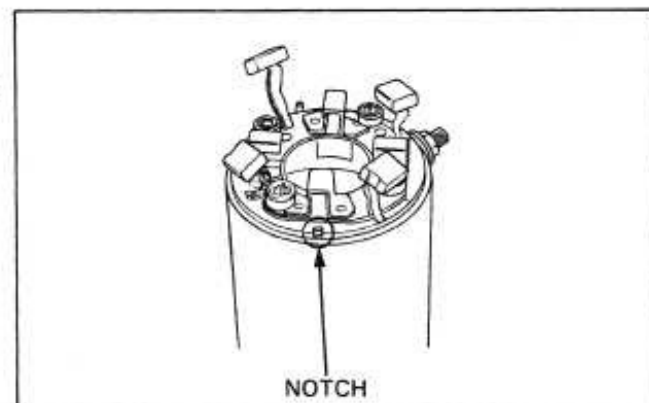

Carefully insert the brushes into the brush holder.

CAUTION

- The sliding surfaces of the brushes can be damaged if they are not installed properly.

Apply grease to both ends of the armature shaft.

Push and hold the brushes inside the brush holder, and insert the armature into the case and through the brush holder from the rear side.

When inserting the armature into the case, hold the armature tightly to keep the magnet from pulling the armature against the case.

CAUTION

- The coil may be damaged if the magnet pulls the armature against the case.

Insert the shims in the correct order on the armature shaft. (For applicable models only.)

Insert the O-ring. (For applicable models only.)

Align the mark (that you made earlier) and install the covers.

CAUTION

- When installing the cover, take care to prevent damaging the oil seal lip with the shaft.

Tighten the cover screws.

For starter motors that are mounted within a motor mount hole, check for a damaged O-ring. In order to prevent damage, grease the O-ring.

Refer to the Model Specific manual for installation.

CAUTION

- Overtightening the cable terminal nuts may cause the terminals to turn inside the starter motor, resulting in serious damage to the inner connectors.

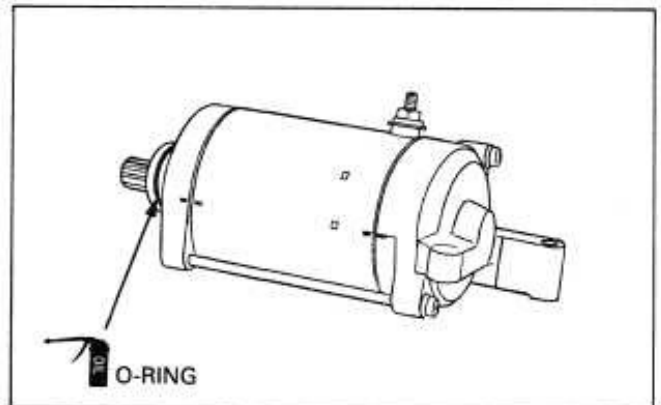
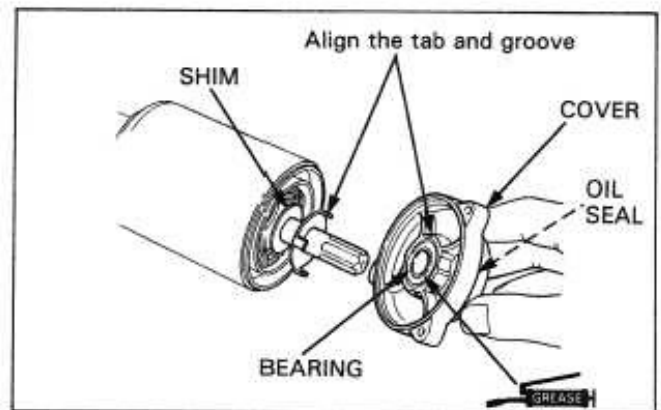
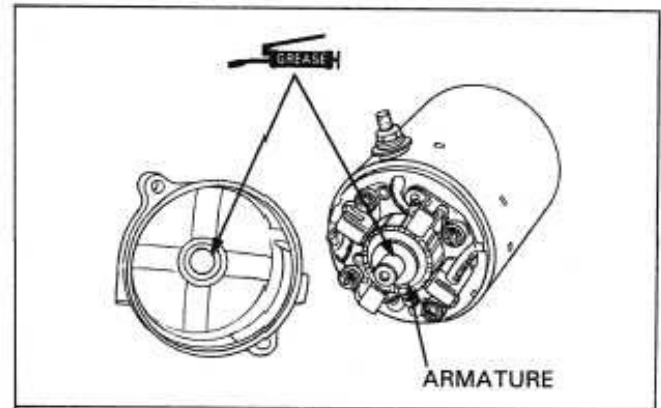

ELECTRIC STARTER/STARTER CLUTCH

STARTER RELAY SWITCH

The starter system can be divided into two basic circuits. There are the clutch safety type (A circuit) and the brake safety type (B circuit).

(A) When the starter switch is turned ON, battery voltage reaches the starter relay switch.

If the neutral or clutch switch of the ground line is turned ON, current flows through the relay and the starter motor operates.

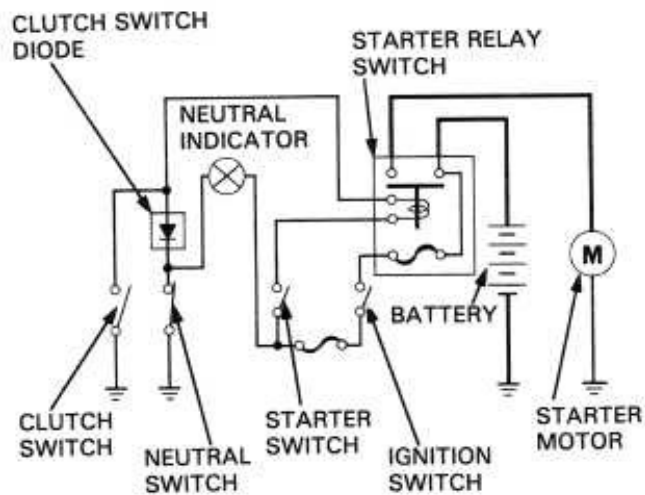

(B) When the brake light switch is turned ON, the same voltage as that at the brake light switch is applied to the relay switch. If the starter switch is turned ON, current flows through the relay and the starter motor operates. This type is commonly used with a centrifugal clutch.

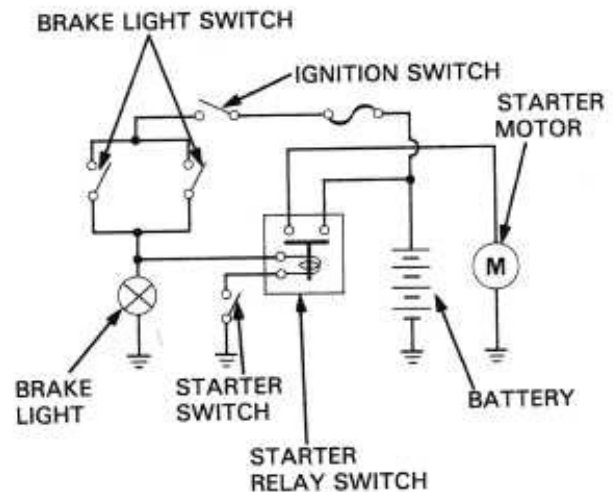

INSPECTION

If you suspect a problem with the starter motor/system, check if the starter relay switch "clicks" when it is turned ON. Inspect further for

- Clicks → • Poorly connected B (battery) terminal and M (motor) terminal of the switch. (Check the relay switch.)
- No click → • No relay input voltage (Check relay input voltage.)
 - Faulty relay ground line (Check ground line.)
 - Faulty relay switch (Check relay switch.)

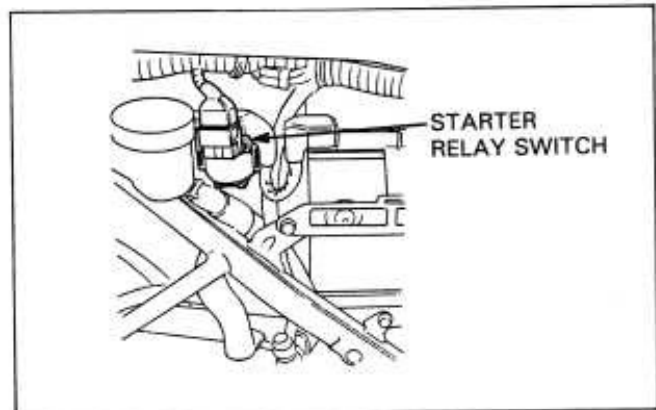

Starter Relay Voltage

«Circuit A»

Measure the voltage between the yellow/red wire (+) and ground at the starter relay switch connector.

If battery voltage is measured only when the starter switch is pressed, the relay is good.

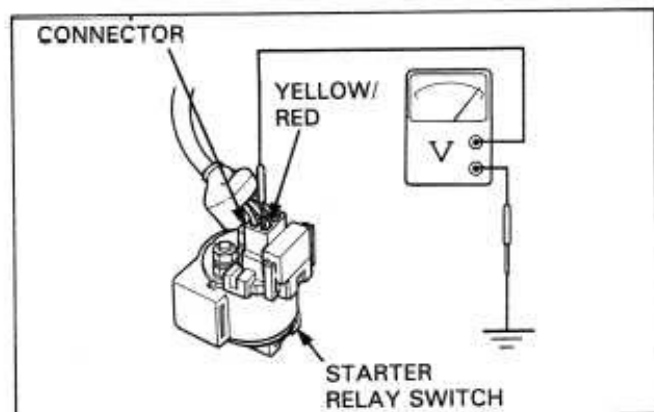

◀Circuit B▶

Measure the voltage between the green/yellow wire and ground at the starter relay switch connector.

If battery voltage is measured when the front or rear brake is applied, the relay is good.

NOTE

- If the brake light adjustment is incorrect, no voltage will appear when the brake is ON.

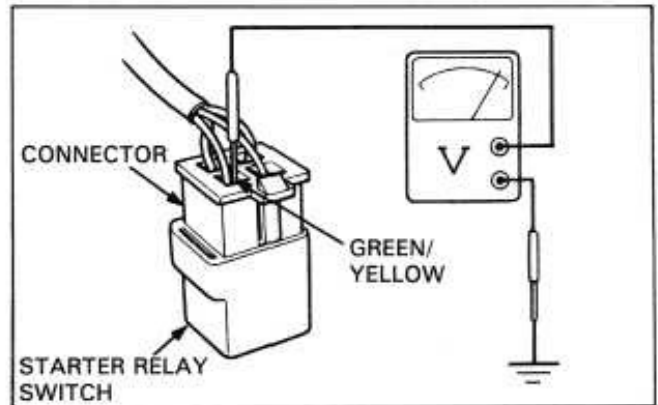

Starter relay switch ground line

◀Circuit A▶

Disconnect the connector from the starter relay switch and check for continuity between the ground wire (green/red) and ground.

If there is continuity when the transmission is in neutral or when the clutch is disengaged, the ground circuit is normal. (In neutral, there is a slight resistance due to the diode.)

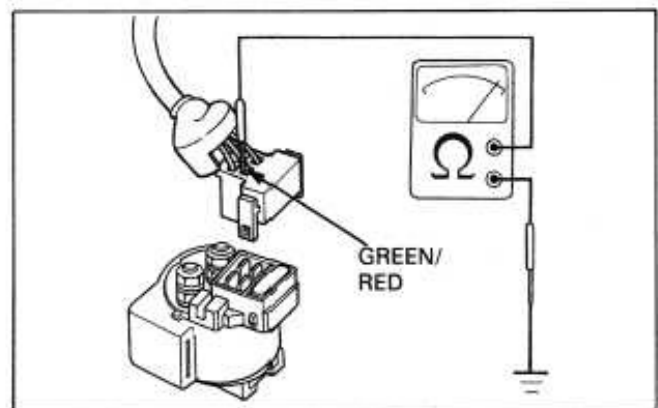

◀Circuit B▶

Disconnect the connector from the starter relay and check for continuity between the ground wire (yellow/red) and ground.

If there is continuity only when the starter switch is pressed, the ground circuit is normal.

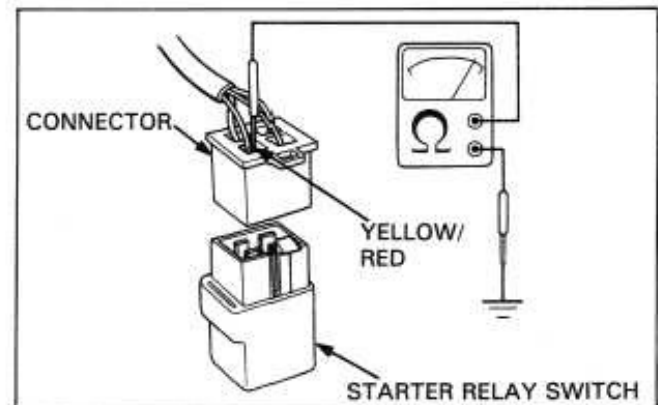

OPERATION CHECK

⚠ WARNING

- Take care to prevent direct short between the battery terminals. The spark could ignite or damage the battery.

Apply battery voltage between the two relay coil terminals. Check for continuity between the B (battery) and M (motor) terminals.

◀Circuit A▶

Apply battery voltage between the yellow/red and green/red terminals.

If there is continuity between B and M terminals, operation is normal.

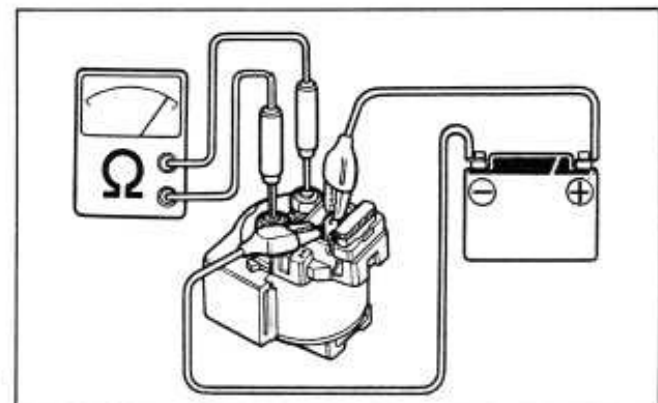

ELECTRIC STARTER/STARTER CLUTCH

◀Circuit B▶

When battery voltage is applied between the starter relay green/yellow wire and yellow/red terminals, there should be continuity between the red and red/white terminals. The terminals are distinguished by the corresponding wire color of the wire harness connector.

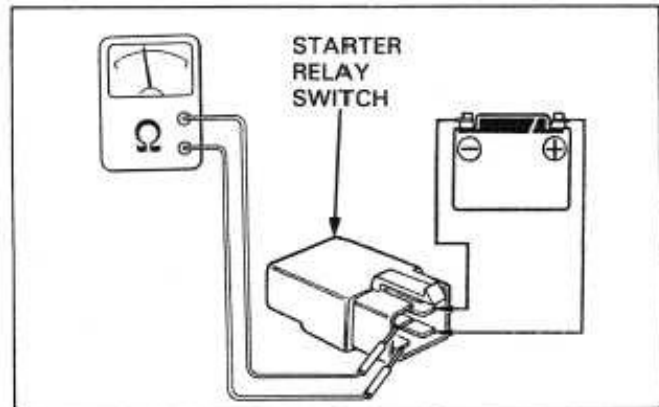

CLUTCH SWITCH DIODE INSPECTION

The purpose of the clutch switch diode is to prevent reverse current flow from the neutral indicator to the clutch switch.

- Faulty diode → Neutral indicator turns ON when clutch is disengaged.
- Loose connections at diode terminal → Starter motor does not turn when transmission is in neutral.

Check for continuity between the diode terminals. When there is continuity, a small resistance value is measured.

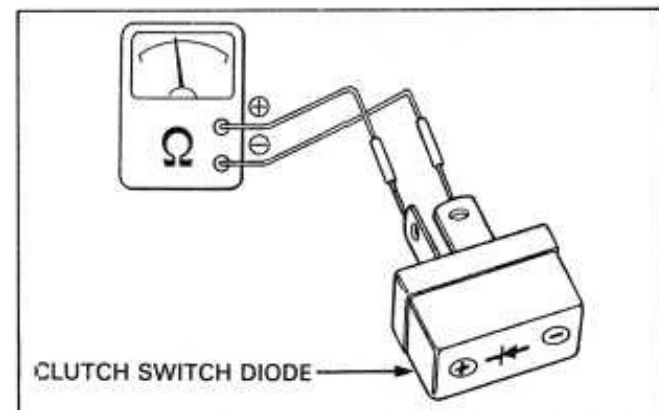

- If there is continuity in one direction and not in the other direction, the clutch switch diode is good.

STARTER CLUTCH INSPECTION

Refer to the Model Specific manual for starter clutch removal and installation.

Install the driven gear into the housing.
With all parts assembled, check the starter clutch.

- Check that the gear, or sprocket, turns smoothly in one direction and locks up in the other direction.

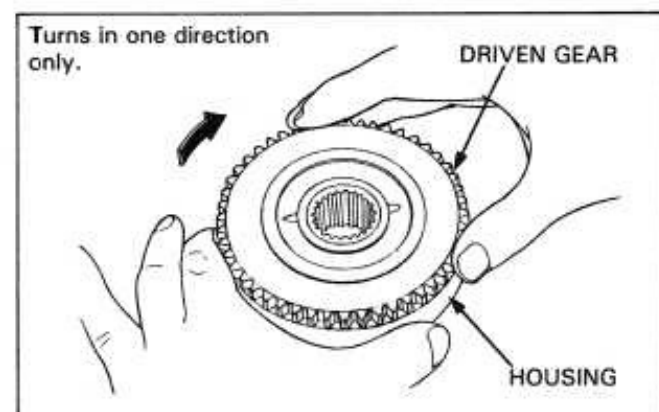

Disassemble the housing.

- Damaged roller contact surface of the gear/sprocket → Replace with a new one.
- Damaged roller contact surface of the housing → Replace with a new one.
- Damaged roller → Replace with a new one.
- Deformation or damage to the spring → Replace with a new one.

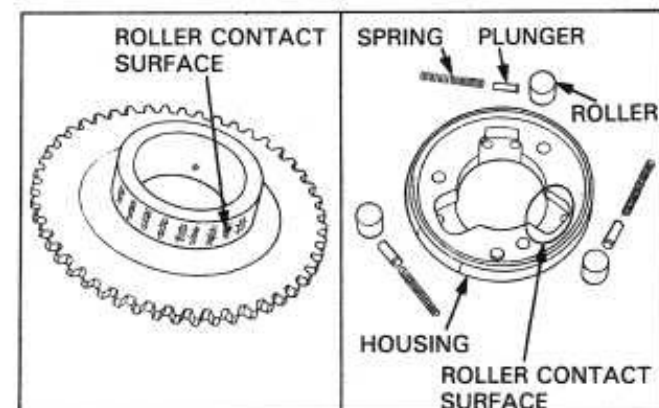

With a one-way sprag clutch, check each sprag, the clutch housing, and all inner contact surfaces.

- Abnormal wear or damage to sprag → Replace with a new one.
- Irregular movement of the sprag → Replace with a new one.
- Damage to the clutch housing or inner portion contact surface → Replace with a new one.

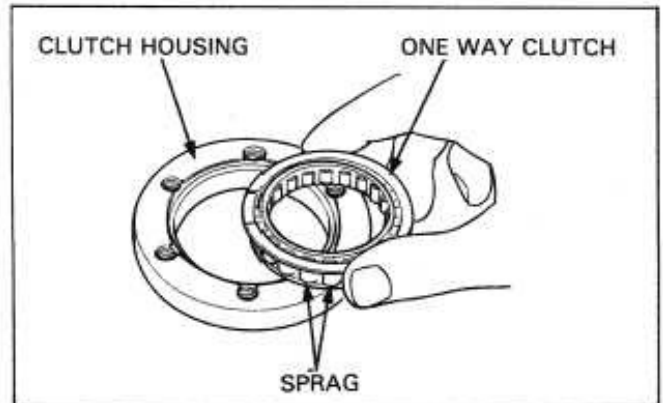

STARTER PINION INSPECTION

Refer to the Model Specific manual for starter pinion removal and installation.

Check the pinion and reduction gears for damage and/or abnormal wear. Check the gear journals for abnormal wear. Replace parts as required.

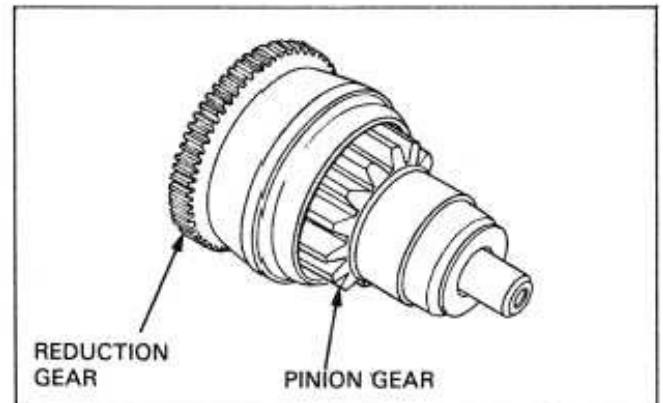

Check if the pinion gear moves smoothly along the axis.

- If it does not, replace it.

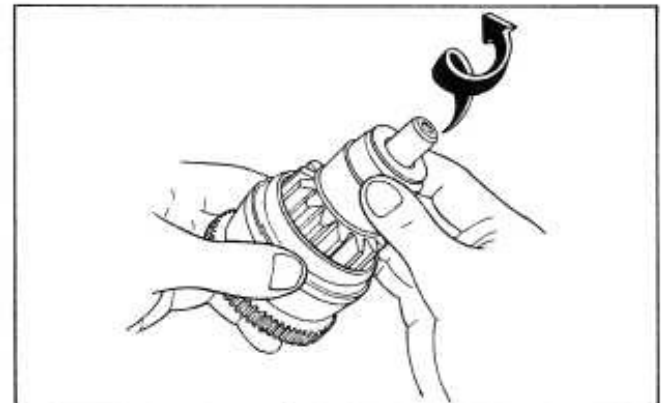

MEMO

25. LIGHTS/METERS/SWITCHES

SERVICE INFORMATION	25-1	LOW FUEL INDICATOR	25-8
OIL PRESSURE WARNING LIGHT (4-STROKE ENGINE)	25-2	FUEL PUMP	25-9
OIL LEVEL INDICATOR (2-STROKE ENGINE)	25-2	HEADLIGHT BULB	25-11
FAN MOTOR SWITCH	25-4	SWITCHES	25-12
COOLANT TEMPERATURE GAUGE	25-5	TURN SIGNAL LIGHTS	25-16
FUEL GAUGE	25-7	HORN	25-17
		SIDE STAND SWITCH	25-18
		SIDE STAND INDICATOR	25-19

SERVICE INFORMATION

▲ WARNING

- Halogen headlight bulbs become very hot while the headlight is ON, and remain hot for a while after they are turned OFF. Be sure to let them cool down before servicing.

Use an electric heating element to heat the water/coolant mixture for thermo sensor inspection.

▲ WARNING

- Keep all flammable materials away from the electric heating element. Wear protective clothing, gloves and eye protection.
- Refer to section 21 for general service rules for electrical components.
- This section covers general inspection/service procedures for lights, meters and switches. Refer to the model Specific manual for the location and arrangement of components on the model being serviced.
- Note the following when replacing the halogen headlight bulb:
 - Wear clean gloves while replacing the bulb. Do not put finger prints on the headlight bulb, as they may create hot spots on the bulb and cause it to break.
 - If you touch the bulb with your bare hands, clean it with a cloth moistened with alcohol to prevent its early failure.
 - Be sure to install the dust cover after replacing the bulb.
- A continuity test can be made with the switches installed on the motorcycle.
- Check the battery condition before performing any inspection that requires proper battery voltage.
- There are two types of lighting systems: AC lighting that takes power from the alternator coil, and DC lighting that takes power from the battery. On DC lighting systems, the headlight comes on without starting the engine. On AC lighting systems, the headlight comes on when the engine starts. (Refer to section 21).

OIL PRESSURE WARNING LIGHT (4 stroke engine)

THEORY

When the oil pressure is below the specifications, the oil pressure switch senses it and the oil pressure warning light comes on. It should be OFF while the engine is running.

INSPECTION

- Oil pressure warning light does not come on with the ignition switch turned ON.

1. Disconnect the oil pressure switch wire and turn the ignition switch ON. Check for battery voltage between the wire and ground.



2. Check for voltage between the black/brown terminal of the instruments and ground.

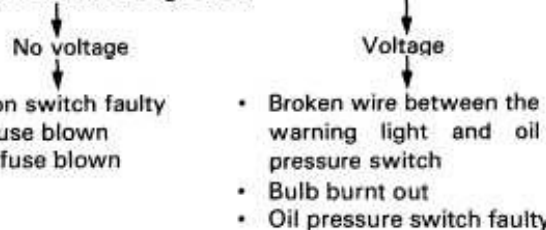

- Oil pressure warning light stays on while the engine is running.

1. Check the engine oil level.



2. Disconnect the oil pressure switch wire and turn the ignition switch ON.

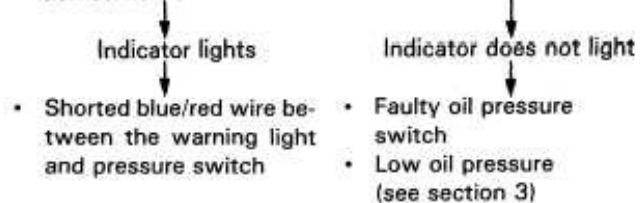

OIL LEVEL INDICATOR (2 stroke engine)

THEORY

The oil level switch float in the oil tank moves up and down depending on the volume of oil in the tank. When the oil level is low, the float also goes down and the reed switch (oil level switch) circuit is closed by the magnetic force of the float. When the ignition switch is turned ON, current flows through the reed switch and the oil level indicator comes on.

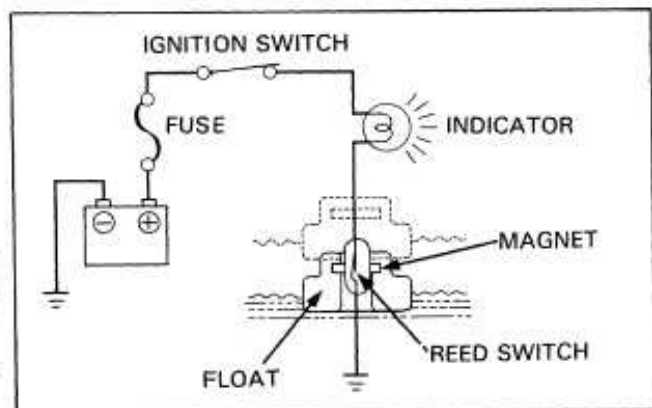
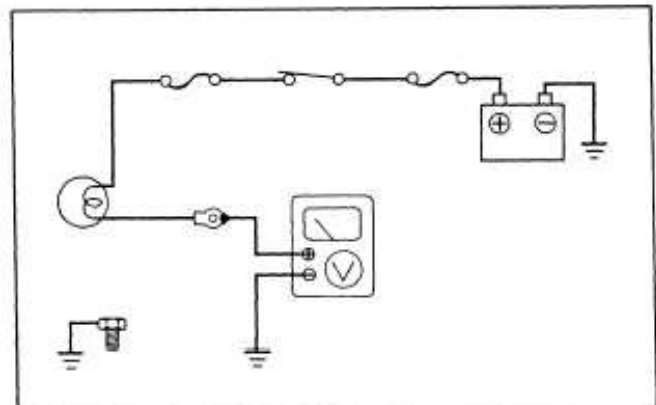
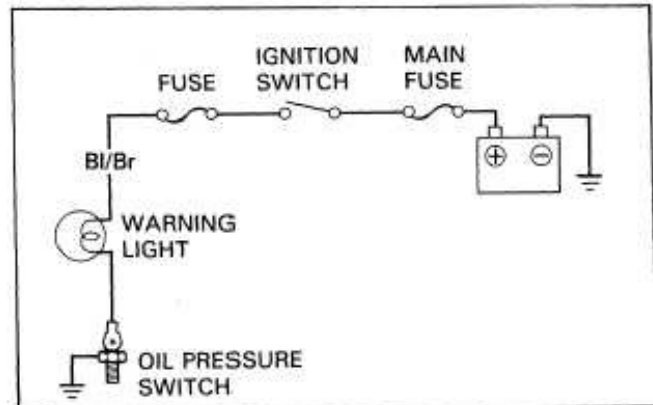

INSPECTION

- Oil level indicator comes on when the oil in the tank reaches a certain level. (Oil level is not below spec.)

1. Disconnect the wires from the oil level switch and turn the ignition switch ON.

Indicator lights

Indicator does not light

- Shorted wire between the indicator and oil level switch
- Faulty oil level switch

- Oil level indicator does not come on with no oil or a low oil level in the tank.

1. Disconnect the wires from the oil level switch and connect a jumper wire between the wire terminals. Turn the ignition switch ON and check the indicator.

Indicator does not come on

Indicator comes on

- Faulty oil level switch
- Poor wire connection

2. Disconnect the wires from the oil level switch and check for voltage between the wire and ground.

No voltage

Voltage

- Broken wire between the oil level indicator and level switch
- Burnt bulb
- Faulty oil level switch
- Poor oil level switch wire connection

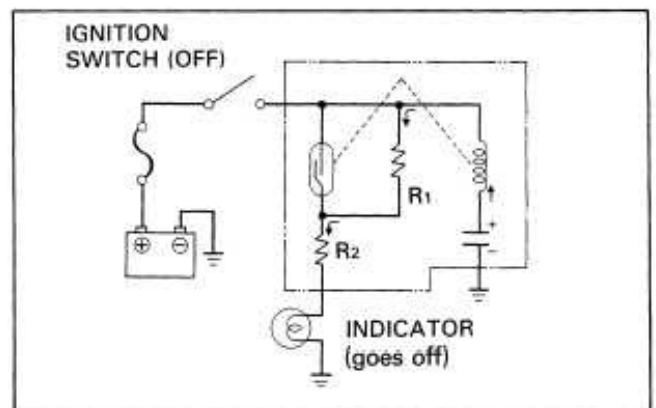
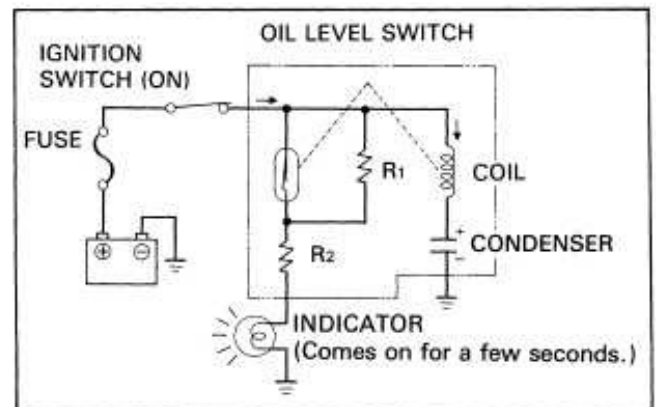
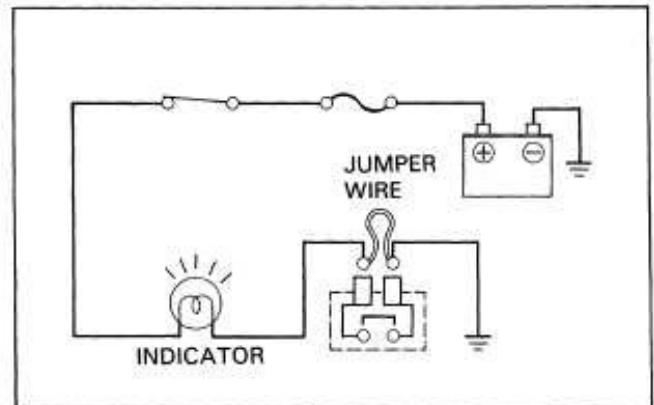
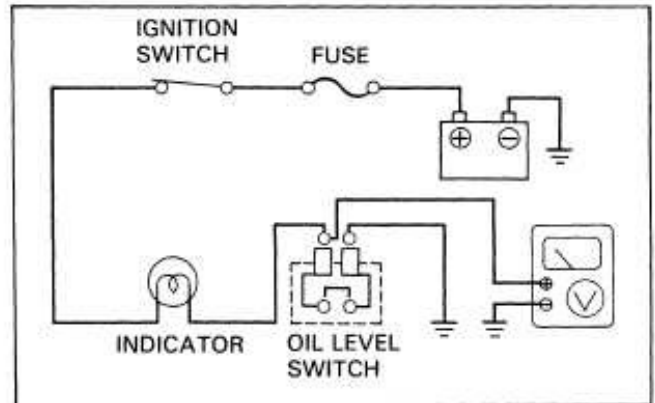

TIMER TYPE INDICATOR THEORY

A timer type indicator has a bulb check function to check the oil level indicator for proper operation.

When the ignition switch is turned ON, current flows through the exciter coil to the condenser, generates an electromagnetic force at the exciter coil and closes the reed switch circuit. Current flows from the reed switch through the resistor R₂ to the oil level indicator and turns it on. When the condenser is fully charged, current flow through the exciter coil to the condenser decreases and, consequently, electromagnetic force at the coil decreases. The reed switch opens and the oil level indicator turns off.

When the ignition switch is turned OFF, current stored in the condenser flows through the exciter coil and resistors R₁ and R₂ to the oil level indicator. The oil level indicator does not come in this case.

LIGHTS/METERS/SWITCHES

TIMER TYPE INDICATOR INSPECTION

- Oil level indicator comes on when the oil in the tank reaches a certain level. (Level is not below spec.)
 - Faulty oil level switch
 - Shorted wire harness
- Oil level indicator does not come on with no oil or a low oil level in the tank.

- Disconnect the oil level switch connector and connect a jumper wire between the power supply wire (black or black/brown) terminal and the indicator wire (green/red) terminal to short. Turn the ignition switch On and check the oil level indicator.

Indicator does not come on

Indicator comes on

- Faulty oil level switch
- Poor switch connection.

- Disconnect the oil level switch connector and check for voltage between the power supply wire (black or black/brown) and ground.

Voltage

No voltage

- Broken power supply wire
- Faulty sub fuse
- Faulty ignition switch
- Poor sub fuse connection.

- Connect the jumper wire between the power supply and oil level indicator wires to short. Check for voltage between the indicator wire and ground.

Voltage

No voltage

- Burnt bulb
- Faulty ground
- Broken indicator wire

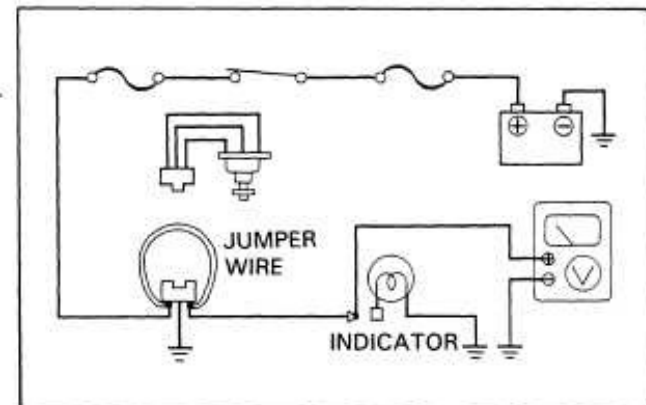
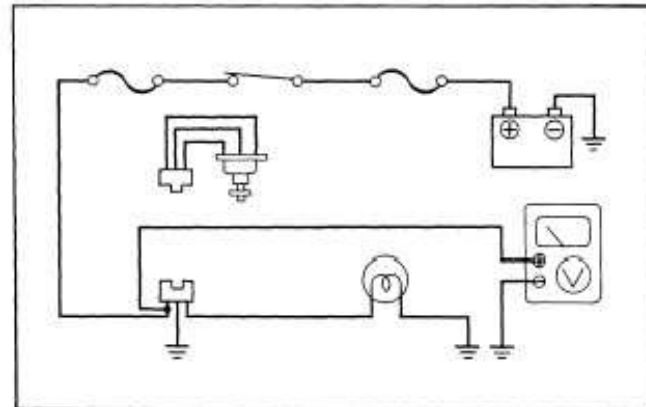
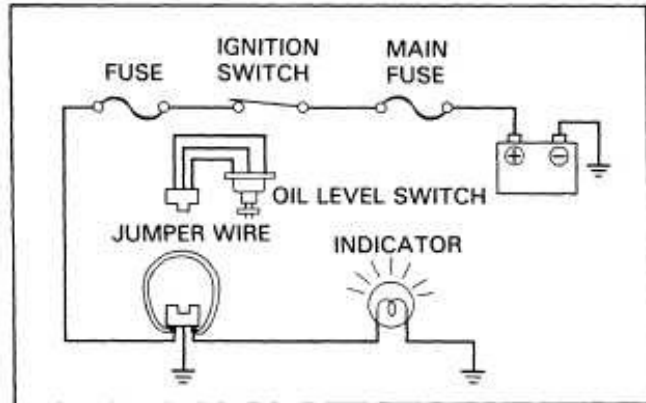

FAN MOTOR SWITCH

NOTE

- The fan motor may continue to run, even when the ignition switch is turned OFF. However, this does not necessarily indicate trouble.

When the coolant temperature rises to a certain level, the fan motor switch turns on to operate the motor. When the coolant temperature is below the specification, the switch turns off to stop the fan motor.

NOTE

- Check the coolant level and bleed air from the cooling system if the coolant is apt to overheat. (See page 5-6 for coolant replacement and air bleeding.)

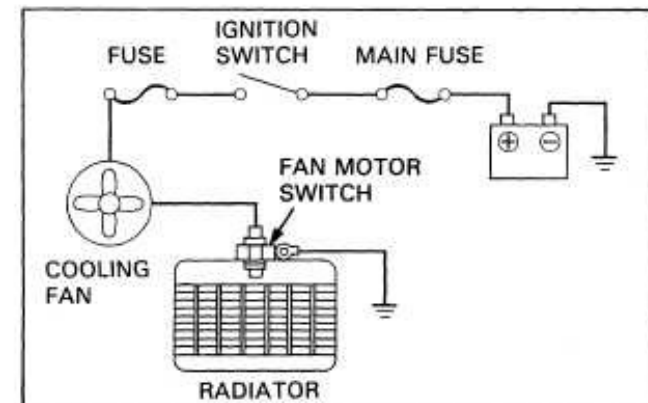

INSPECTION

• **Fan motor does not stop.**

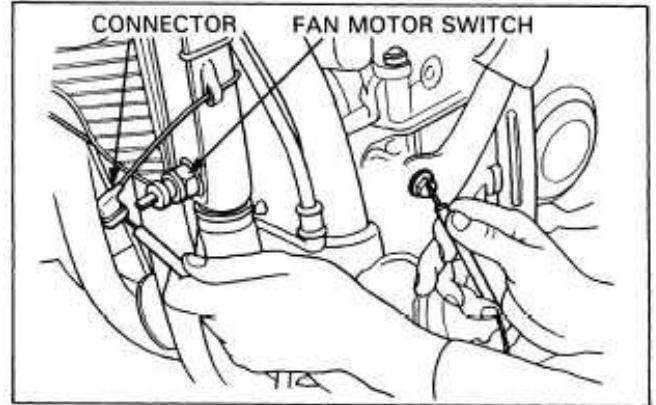
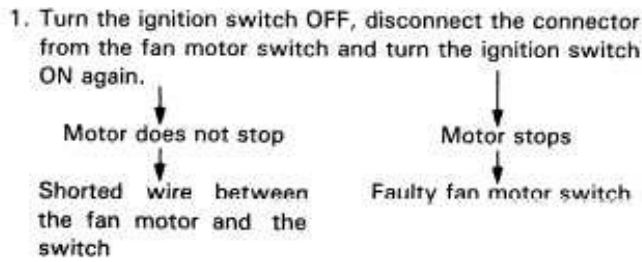

• **Fan motor does not start.**

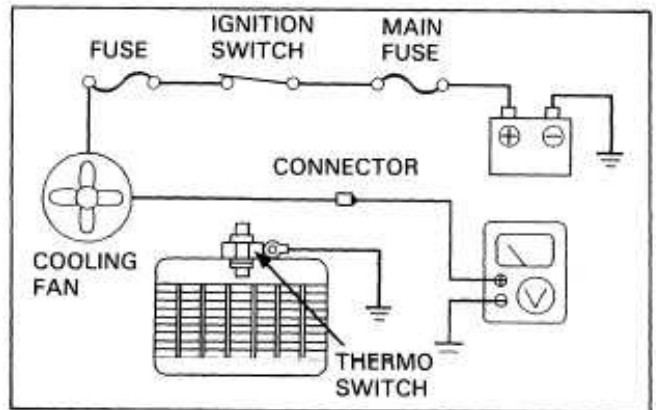
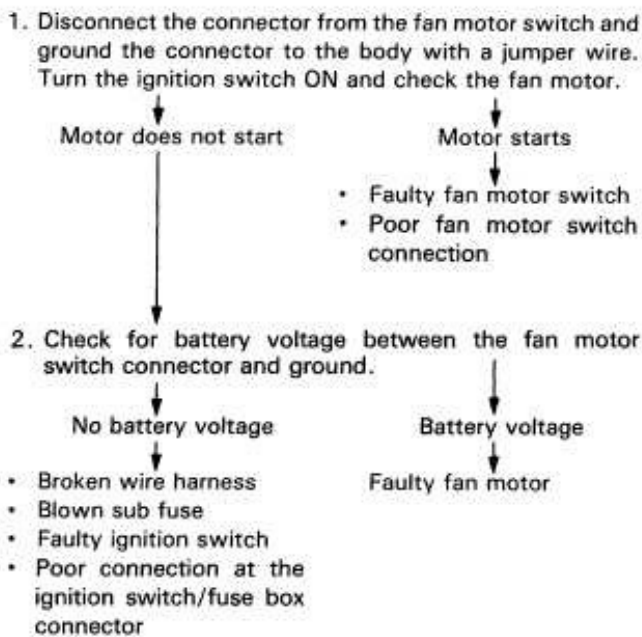

COOLANT TEMPERATURE GAUGE

The thermo sensor changes the amperage of the current that flows to the coolant temperature gauge and moves the gauge needle according to the change in coolant temperature.

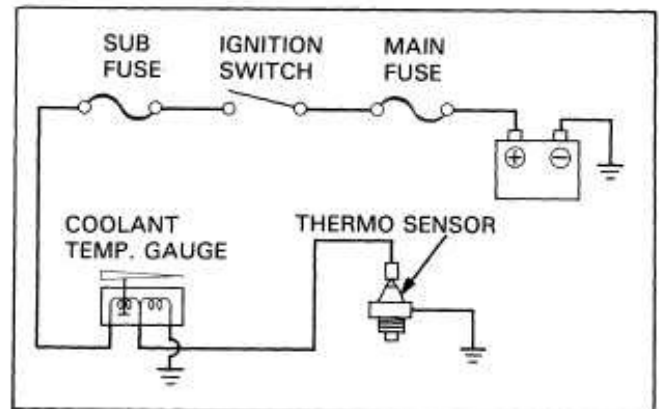

LIGHTS/METERS/SWITCHES

INSPECTION

1. Disconnect the wire from the thermo sensor.
Ground the thermo sensor wire using a jumper wire.
Turn the ignition switch ON and check the coolant gauge.
Disconnect the thermo sensor wire from the ground immediately if the gauge needle moves fully to H.

CAUTION

- Immediately disconnect the wire from the ground if the needle moves to H (hot) to prevent damage to the gauge.

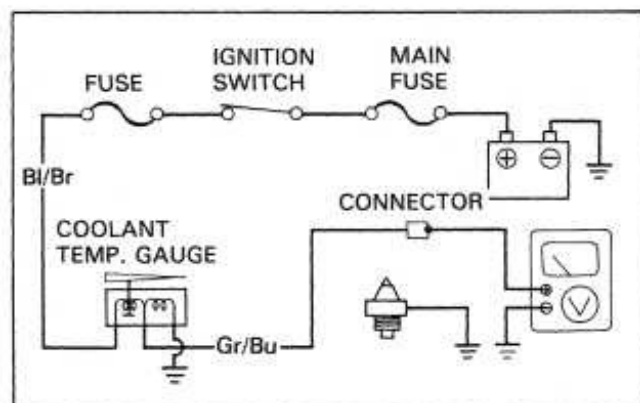
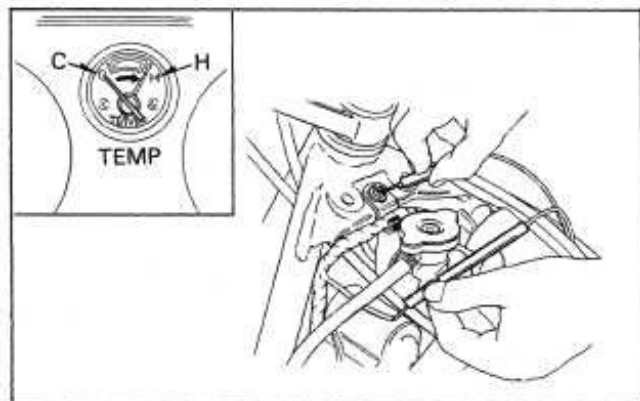
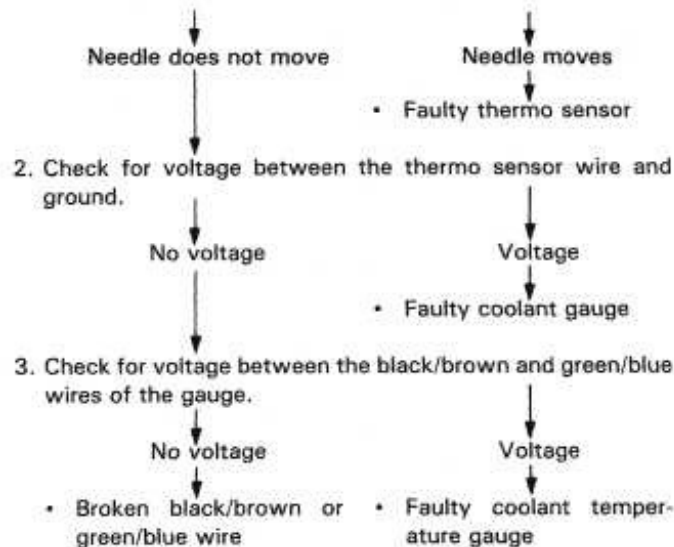

THERMO SENSOR INSPECTION

Drain the coolant (see page 5-6).
Disconnect the wire from the thermo sensor and remove it.
Suspend the thermo sensor in a pan of coolant (50-50 mixture) over an electric heating element and measure the resistance through the sensor as the coolant heats up. (Refer to the Model specific manual for the specified resistance.)

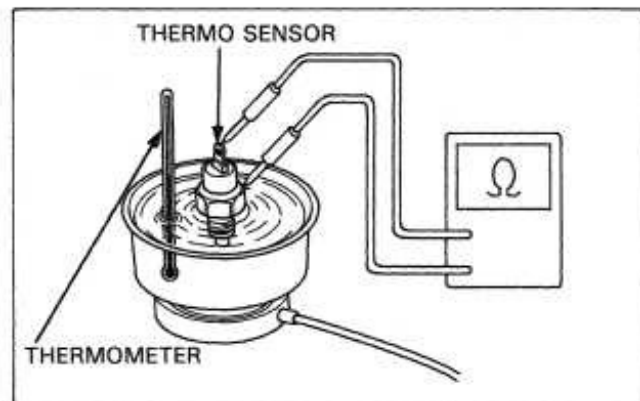

WARNING

- Keep flammable materials away from the electric heating element.
- Wear insulated gloves and eye protection.

NOTE

- Soak the thermo sensor in coolant up to its threads with at least 40 mm (1.57 in) from the bottom of the pan to the bottom of the sensor.
- Keep temperature constant for 3 minutes before testing. A sudden change of temperature will result in incorrect readings. Do not let the thermometer or thermo sensor touch the pan.
- Apply sealant to the thermo sensor threads prior to reinstallation.

FUEL GAUGE

Fuel unit resistance changes in relation to the level of the fuel unit float. The fuel gauge needle is moved by the varying amperage that flows through the fuel gauge.

There are two types of fuel gauges: The "Return type" where the needle returns to "Empty" when the ignition switch is turned OFF, and the "Stop type" where the needle stays in position when the ignition switch is turned OFF.

Check the fuel gauge if its needle does not move.

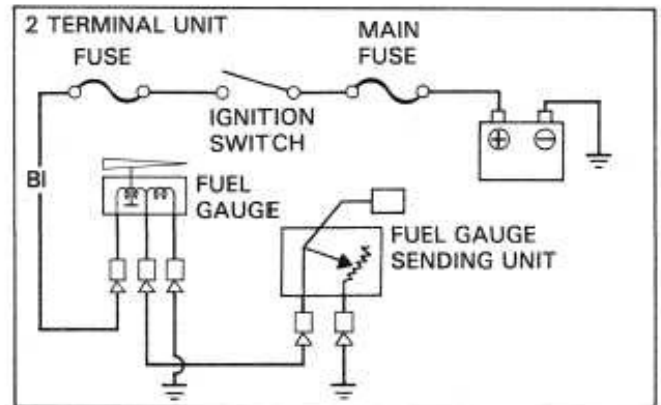

INSPECTION

1. If the fuel unit connector has 2 terminals, short the gauge terminals with a jumper wire.

If the unit connector has 3 terminals, short the gauge side yellow/white terminal and the green terminal with a jumper wire.

Turn the ignition switch ON and check the gauge needle.

Needle does not move

Needle moves

- Check the fuel unit.

2. Check for continuity between the unit and fuel gauge.

Continuity

No continuity

- Broken wire between the unit the gauge

3. Check for voltage at the black or black/brown (positive power line) and ground wire of the fuel gauge.

No voltage

Voltage

- Broken positive power line
- Faulty fuel gauge line

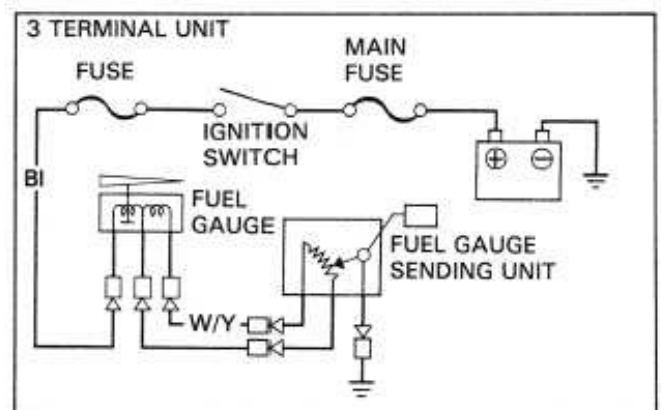

FUEL UNIT INSPECTION

Refer to the Model Specific manual for the fuel unit removal/installation and inspection specifications.

1. Connect the fuel unit connector.
Turn the ignition switch ON.

Move the float up and down to be sure that the fuel gauge needle moves to "F" and "RES".

If the needle does not move, go to step 2.

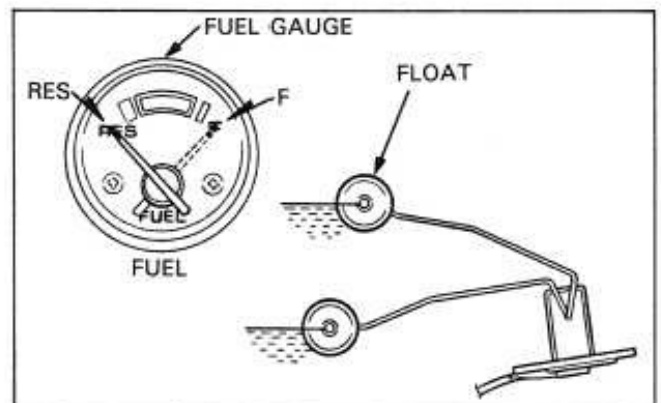

LIGHTS/METERS/SWITCHES

2. Measure the resistance between the connector terminals with the float in the full up and down positions.

If the resistance is normal, check the fuel gauge.
If the resistance is not normal, replace the fuel unit.

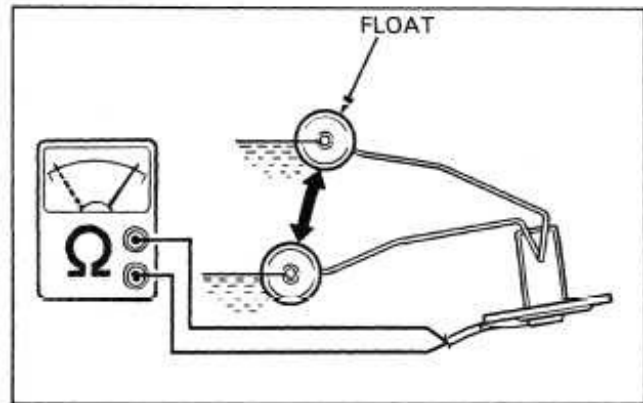

LOW FUEL INDICATOR

A thermistor is built into the fuel level sensor in the fuel tank. The fuel warning light's function is controlled by the thermistor's automatic heat generation.

When the thermistor is submerged in gasoline, heat generated by the thermistor is radiated by the liquid (gasoline), and the self heating action is reduced. As the resistance is maintained and the current does not flow at this time, the fuel warning light does not turn on.

When the thermistor is exposed, i.e. fuel level is low, radiation of heat decreases and the self heating increases. When the resistance drops below a specified point, current flows and the low fuel indicator turns on.

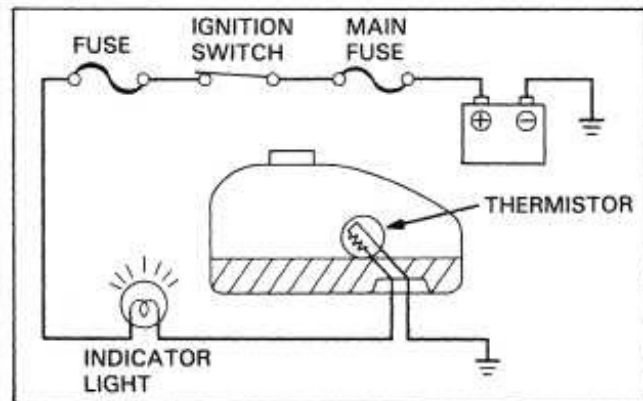

INSPECTION

If the low fuel indicator does not go off, check as noted below.

Check for battery voltage between the fuel level sensor connector terminals.

Battery voltage

- Faulty fuel level sensor
- Poor connection

No battery voltage

- Shorted wire between the indicator light and sensor
- Faulty ground

If the fuel warning light does not turn on, check as noted below:

1. Check for battery voltage between the fuel level sensor connector terminals.

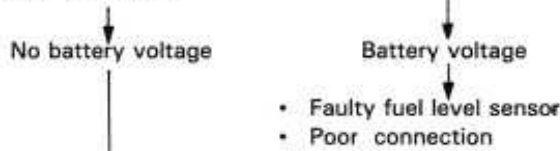

2. Check for battery voltage between the battery side of the indicator wire and ground.

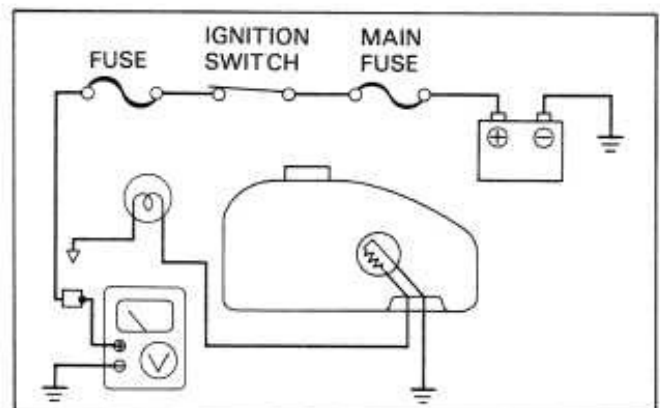
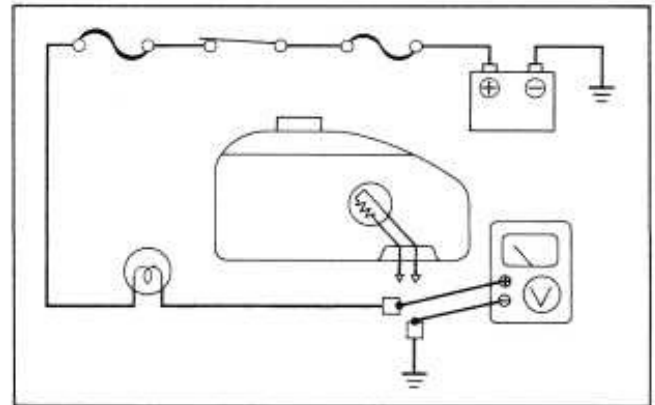
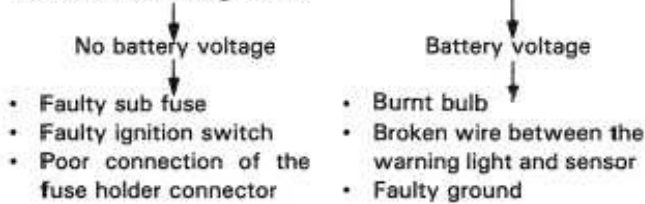

FUEL PUMP

DESCRIPTION

Certain models are equipped with a low pressure electromagnetic fuel pump to supply fuel to the carburetor.

When the engine is started, the switch is turned on by the function of the fuel cut-off relay (refer to the description of fuel cut-off relay), which generates an electromagnetic force at the coil and moves the plunger and diaphragm up. Valve A is then opened by vacuum action and the fuel flows into the diaphragm chamber. The plunger pushes the switch up and turns it off. As the electromagnetic force at the coil is shut down, the plunger and diaphragm are returned by the spring and the fuel in the diaphragm chamber is sent to the carburetor through valve B.

Certain models of this fuel pump have a built-in fuel cut-off relay.

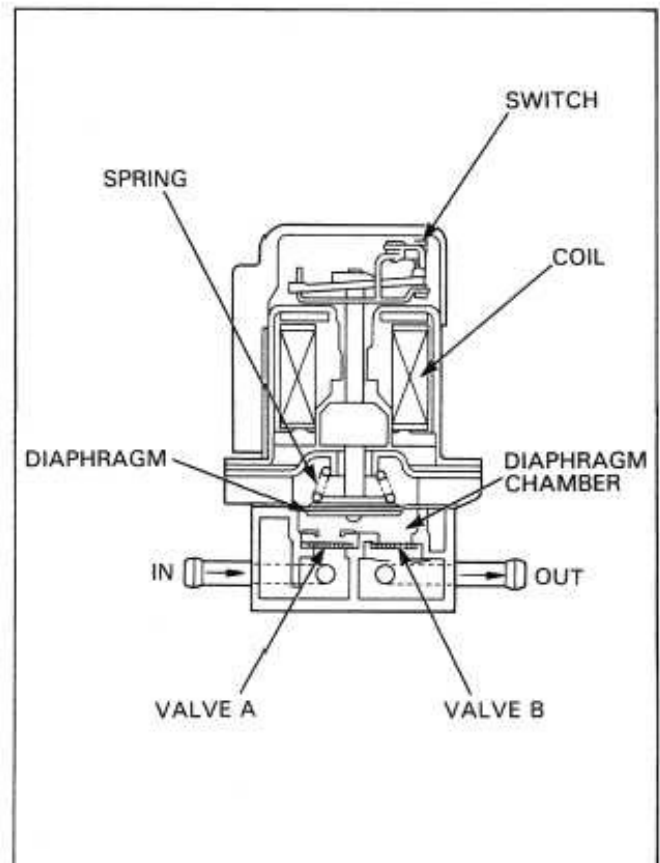

LIGHTS/METERS/SWITCHES

FUEL CUT-OFF RELAY

With the ignition switch ON, current flows to the transistor and thyristor, but it does not flow to the fuel pump.

To fill the carburetor float chamber with fuel when the ignition switch is turned ON, certain fuel cut-off relays have a timer function that sends current to the fuel pump for a few seconds.

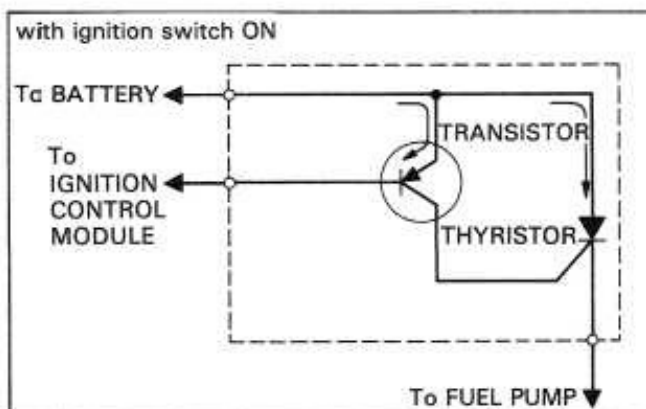

While the engine is running, pulses are transmitted from the ignition control module to the ignition primary circuit and, when it is transmitted to the transistor, current flows from the transistor to the thyristor to turn it ON. The battery current flows to the fuel pump this way.

As the fuel cut-off relay is controlled by the ignition primary circuit, the relay does not operate unless the ignition primary circuit operates properly.

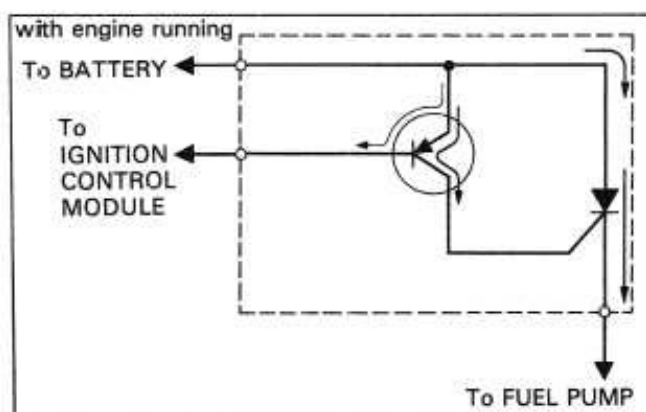

INSPECTION

Turn the ignition switch ON and perform the following inspections.

1. Check for battery voltage between the black wire (+) of the fuel cut-off relay connector (pump connector if the relay is built in the pump) and ground (-).

Battery voltage

No battery voltage

- Broken black wire
- Faulty sub-fuse
- Faulty ignition switch
- Poor connection of the fuse holder connector

2. Check for continuity between the black/blue wire of the relay connector and ground (or black/yellow wire and green wire of the pump connector, if the relay is built into the pump).

No continuity

Continuity

- Faulty fuel cut-off relay (pump)

3. Disconnect the relay, the short the black and black/blue wires of the relay connector with a jumper wire and check for battery voltage between the black/blue (+) wire and green wire of the pump connector.

No battery voltage

Battery voltage

- Broken green or black/blue wire
- Faulty ground
- Faulty fuel pump

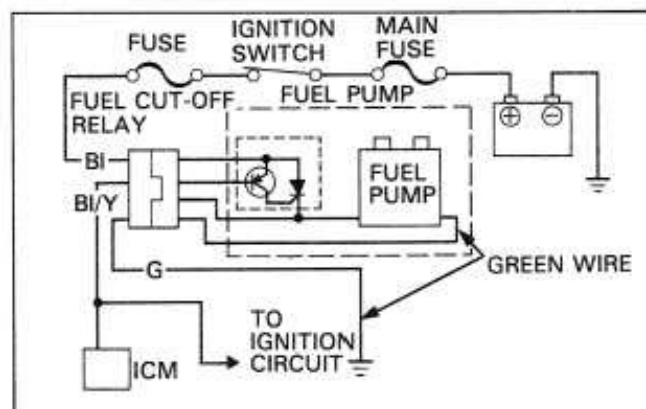
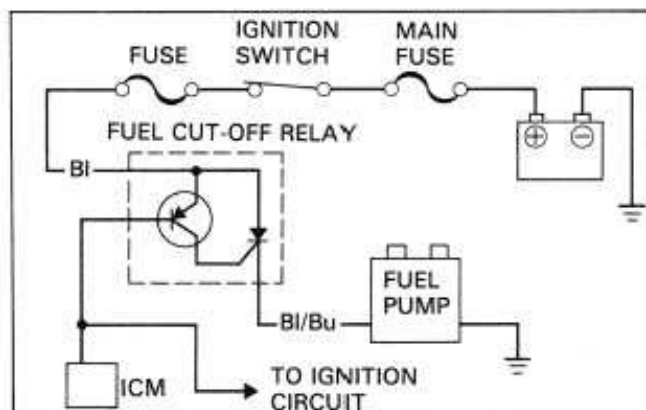

DISCHARGE VOLUME INSPECTION

Turn the ignition switch OFF
Turn on fuel valve. On models with vacuum operated valve, apply vacuum.

Disconnect the fuel pump-to-carburetor tube from the carburetor and place the tube end in a beaker.

NOTE

- If it will be hard to reconnect the tube to the carburetor, disconnect it from the fuel pump instead and connect another tube to the pump (gasoline discharge port).

Refer to step 3 of INSPECTION and short the relay connectors. If the relay is built into the pump, short the black and black/yellow wires.

Turn the ignition switch ON for 5 seconds and run the pump.

Multiply the quantity of fuel pumped by 12. It should be as specified in the Model Specific manual.

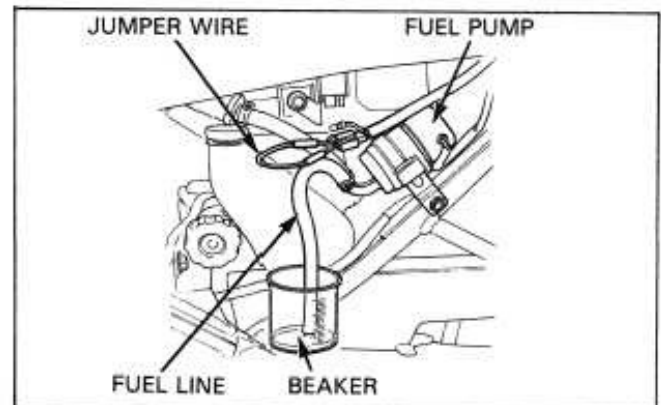

HEADLIGHT BULB

Before replacing the bulb, be sure to check the switches for loose connection of the connectors.

⚠ WARNING

- Halogen headlight bulbs become very hot while the headlight is ON, and remain hot for a while after they are turned OFF. Be sure to turn the ignition switch OFF and let the bulb cool down before replacement.

If you touch the bulb with your bare hands, clean it with a cloth moistened with denatured alcohol to prevent early bulb failure.

CAUTION

- Avoid touching Halogen headlight bulbs. Finger prints can create hot spots that cause a bulb to break.

Be sure to install the dust cover after replacing the bulb.

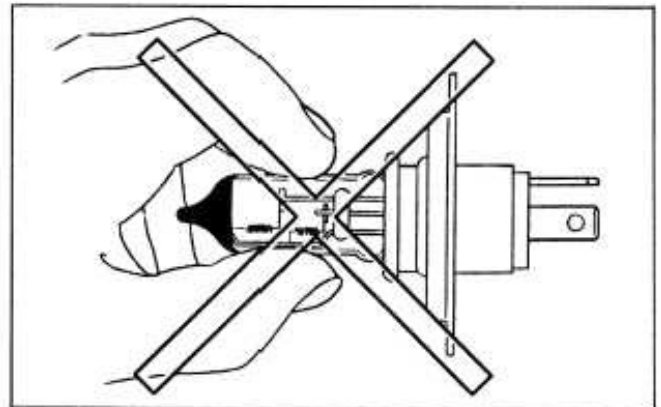

SWITCHES

INSPECTION

Disconnect the connector that is nearest to the switch that you are to inspect and check for continuity between the switch side terminals of the connector.

There should be continuity between the \bigcirc — \bigcirc positions on the continuity chart. (Refer to the Model Specific manual for the continuity chart.)

Example: Turn signal switch

Wire color	Orange	Gray	Blue
Switch position			
L	\bigcirc — \bigcirc		
N			
R		\bigcirc — \bigcirc	

With the turn signal switch at N(neutral), there should be no continuity between the wires.

With the switch at L (left), there should be continuity between the orange and gray wires, and with the switch at R (right), there should be continuity between the blue and gray wires.

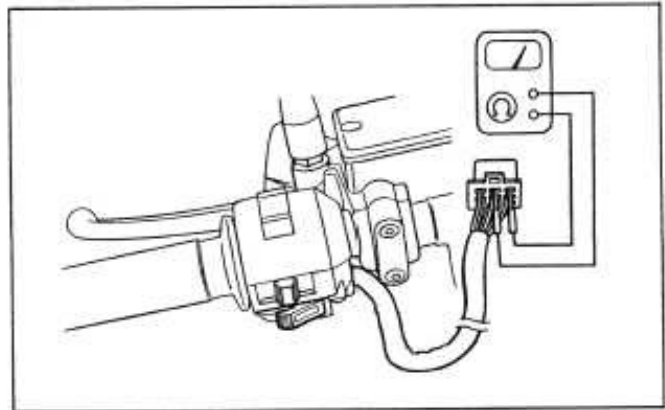

CONTACT BASE REPLACEMENT

When the contact base is mounted with screws:
Remove the ignition switch.

Remove the band and three screws, then remove the switch from the switch cylinder.

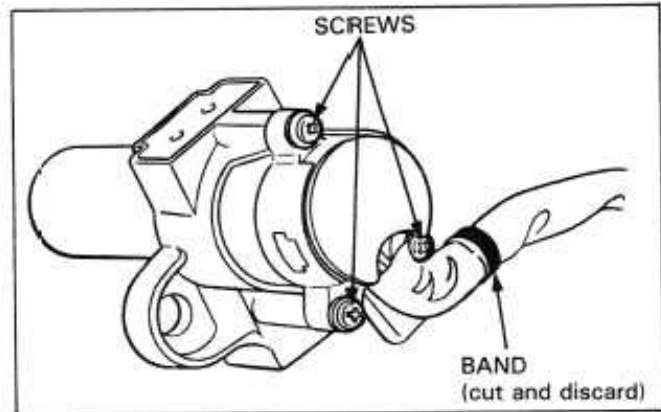

Reassemble the switch and cylinder with the cylinder shaft aligned with the notch in the switch hole.

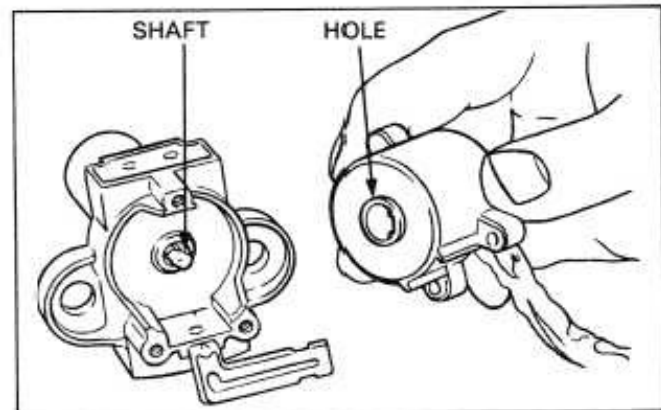

Tighten the contact base with the three screws.

Clamp the wires with a wire band and cut off the excess portion of the band. Check the ignition switch.

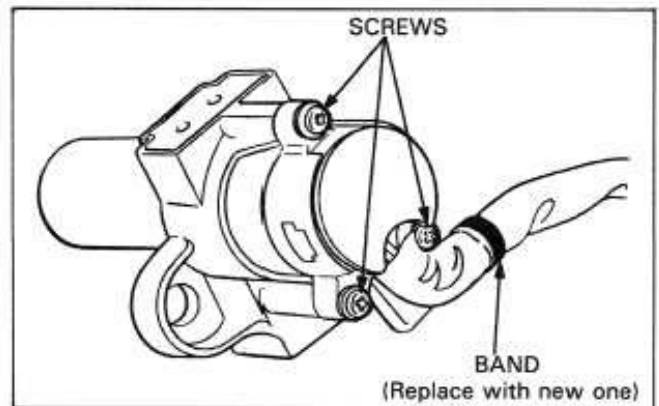

When the contact base is secured with tabs:

Remove the ignition switch and band.

Insert the ignition switch key and turn it to the position between ON and OFF.

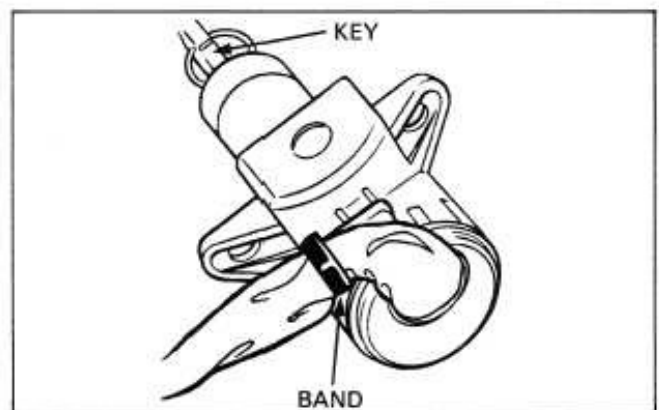

Push the contact base tabs in with a screwdriver to release them from the slots in the ignition switch body, and remove the contact base.

Insert the contact base on the ignition switch body with its tabs aligned with the slots in the ignition switch body.

NOTE

- Be sure that the ignition switch key is in the position between ON and OFF before attempting to reinstall the contact base.

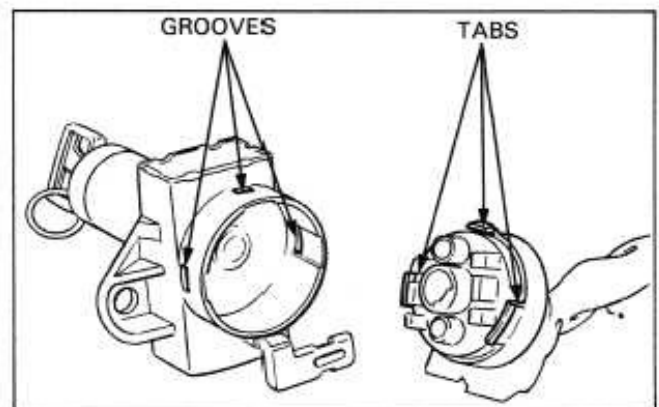

Clamp the wires with a wire band and cut off the excess portion of the band.

Check the ignition switch.

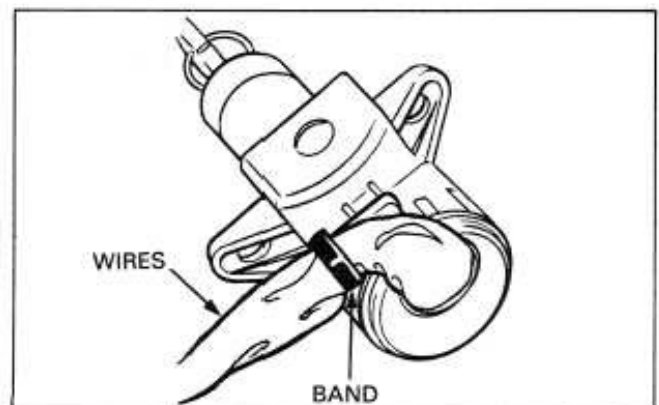

LIGHTS/METERS/SWITCHES

NEUTRAL SWITCH

When the ignition switch is ON and the transmission is in neutral, the neutral switch turns the indicator on.

Some models are equipped with a change switch and/or overdrive switch: Refer to Model Specific manual for change and OD switch inspections.

The change switch detects the gear position by the position of the shift drum and sends a signal to the gear position indicator/ignition control module.

The overdrive switch turns the overdrive indicator on when the transmission is in OD (overdrive) position.

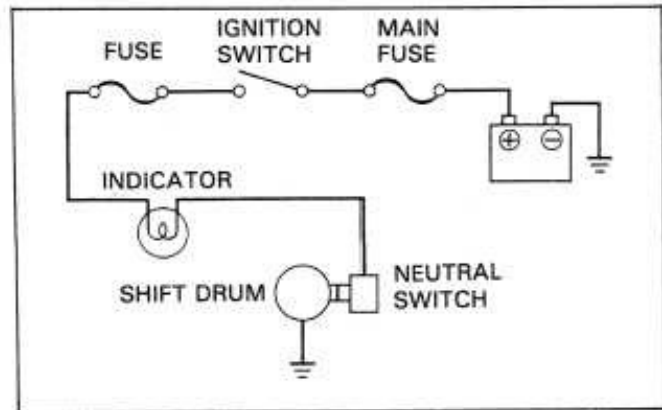

INSPECTION

Neutral indicator does not go off:

Place transmission in gear.

Disconnect the light green/red wire from the neutral switch and turn the ignition switch ON.

Indicator does not light

- Faulty neutral switch

Indicator lights

- Shorted light green/red wire

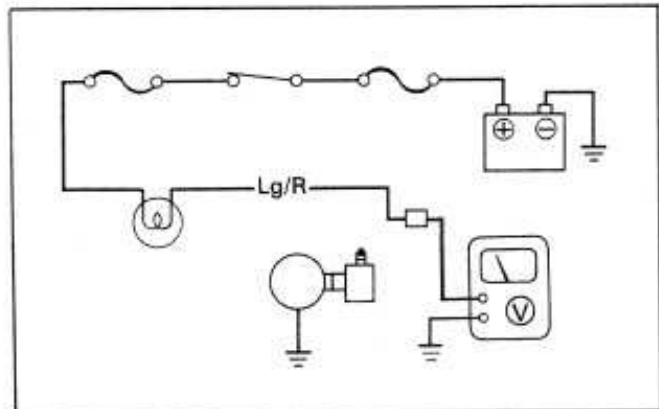

Neutral indicator does not come on:

Disconnect the light green/red wire from the neutral switch and turn the ignition switch ON.

Check for battery voltage between the light green/red wire and ground.

Battery voltage

- Faulty neutral switch

No battery voltage

- Broken light green/red wire between the indicator and neutral switch
- Burnt bulb
- Blown sub fuse
- Poor connection of the fuse connector

CLUTCH SWITCH

The clutch switch allows the starter motor to work if the engine stalls while in gear by disengaging the clutch.

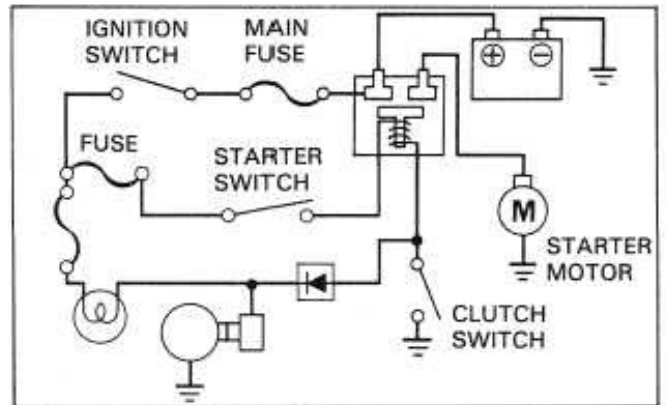

INSPECTION

Check the starter system if the starter motor turns with the transmission in positions other than neutral. The starter motor should turn with the clutch lever pulled in and not turn with the lever released while in gear. If the starter system is not normal, check the following:

Disconnect the wire from the clutch switch and check for continuity between the clutch switch terminals while operating the clutch lever.

When the clutch lever is pulled in:
There should be continuity between the terminals.

When the clutch lever is released:
There should be no continuity between the terminals.

If the clutch switch is normal, check the following:

- Check for shorted wire between the starter relay switch and the clutch switch
- Check the neutral switch

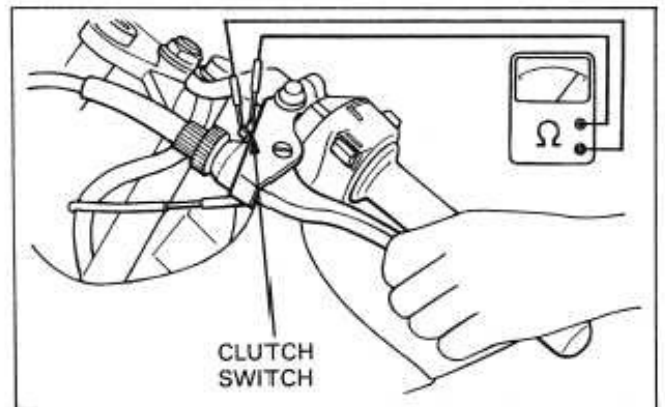

BRAKE LIGHT SWITCH

The brake light comes on when the brake lever (or pedal) is applied.

Starter motor-equipped scooters: To prevent the accidental start up of the scooter, current does not flow to the starter motor unless the brake lever (or pedal) is applied.

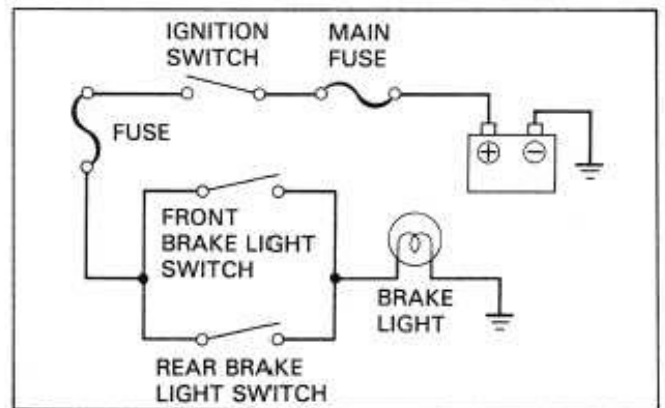

INSPECTION

If the brake light does not come on, check the following:

- Burnt bulb.
- Poor connection of the brake light switch connector.

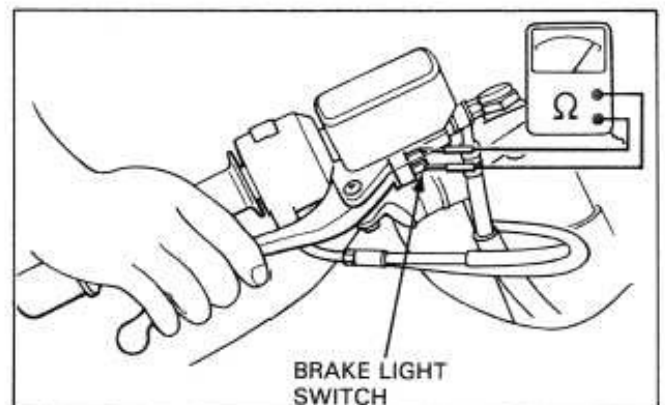

LIGHTS/METERS/SWITCHES

If normal, disconnect the brake light switch connector and check for continuity between the terminals while operating the brake lever (or pedal).

When the brake lever (or pedal) is depressed:

There should be continuity between the terminals.

When the brake lever (or pedal) is released:

There should be no continuity between the terminals.

If the brake light switch is normal, check the following:

- Blown sub fuse
- Ignition switch
- Poor connection of the fuse connector
- Broken wire between the sub fuse and brake light switch
- Broken wire between the brake light switch and brake light

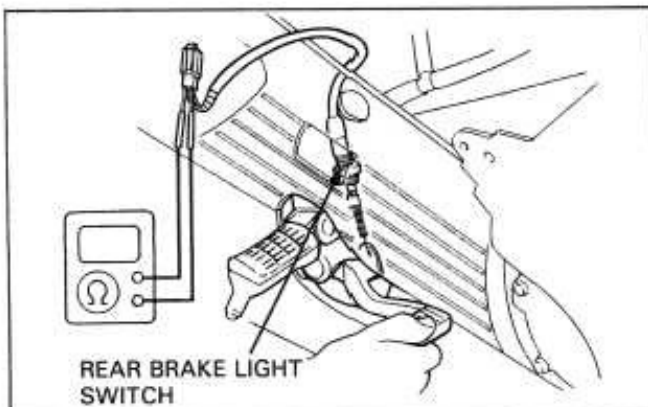

TURN SIGNAL LIGHTS

If the turn signal light does not blink, check the following.

- Is the battery normal?
- Is the bulb burned out?
- Is the bulb of the specified wattage?
- Is the fuse blown?
- Are the ignition and turn signal switches normal?
- Is the connector properly connected?

If normal, check as noted below.

- When the turn signal relay has 2 terminals:

Disconnect the connector from the relay and short the connector with a jumper wire. Turn the ignition switch ON and check the turn signal light by turning the switch ON.

Light does not come on

- Broken wire harness

Light comes on

- Faulty turn signal relay
- Poor connection

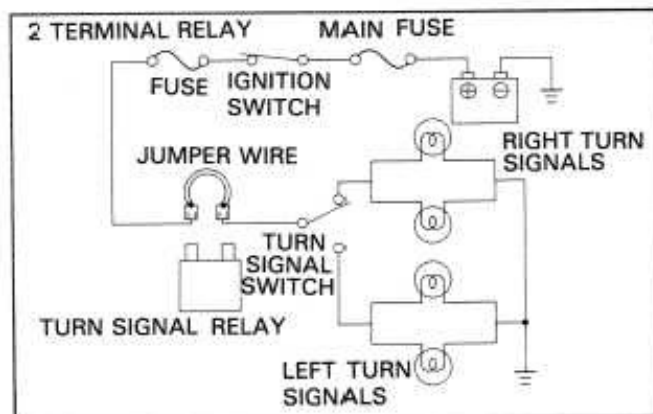

• When the turn signal relay has 3 terminals;

1. Short the black and gray terminals of the turn signal relay connector with a jumper wire. Turn the ignition switch ON and check the turn signal light by turning the switch ON.

Light comes on

Light does not come on

- Broken wire harness

2. Check for continuity between the green terminal of the relay connector and ground.

Continuity

No continuity

- Faulty turn signal relay
- Poor connection
- Broken ground wire

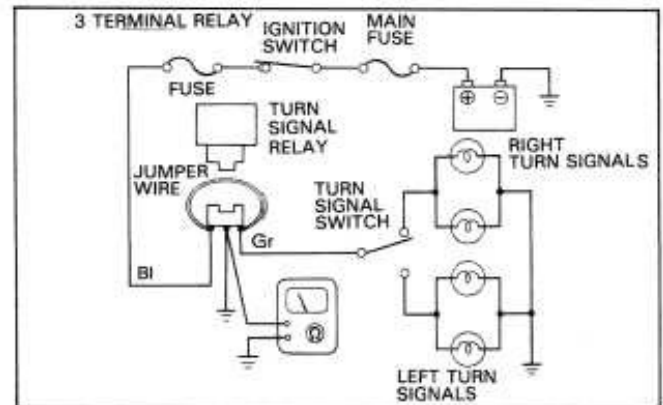

HORN

Horn does not sound:

1. Check the ignition and horn switches. If normal, check the following:
2. Disconnect the wire from the horn. Turn the ignition switch ON, press the horn switch (or start the engine and press the horn switch if your motorcycle is battery-less type) and check for voltage between the light green wire and ground.

Voltage

No voltage

- Broken light green wire
- Faulty sub fuse
- Faulty horn switch

3. Check for continuity between the green wire and ground.

Continuity

No continuity

- Faulty horn
- Broken green wire
- Faulty ground

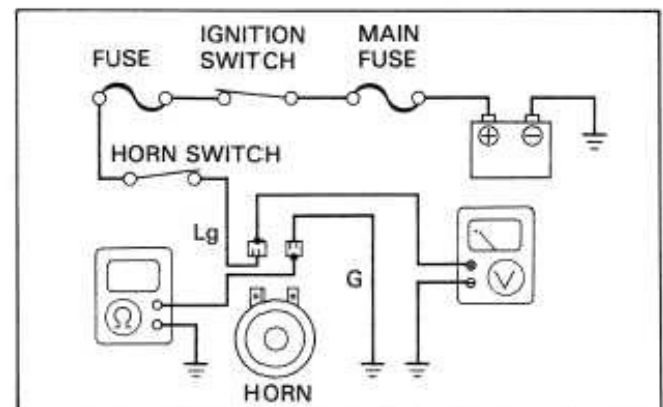

SIDE STAND SWITCH

INSPECTION

NOTE

- If there is an open circuit or poor connection in the ignition circuit of the side stand switch, the following symptoms will occur with the side stand retracted.
 - Models with centrifugal clutch: Starter motor will not operate.
 - Models with manual clutch: Starter motor will not operate with the transmission in gear and the clutch disengaged. (The engine stops when the transmission is shifted into gear.)
 - Models with kick starter: Engine will not start. (No spark at plug.)
- If you suspect the side stand circuit, first check the operation of the side stand indicator. If the indicator operation is normal, the problem is in the side stand circuit.

Disconnect the connector from the ignition control module.

Check for continuity between the side stand switch wire (ignition side: Green/White) of the harness side connector and ground.

- Side stand retracted: Continuity
- Side stand lowered: No continuity

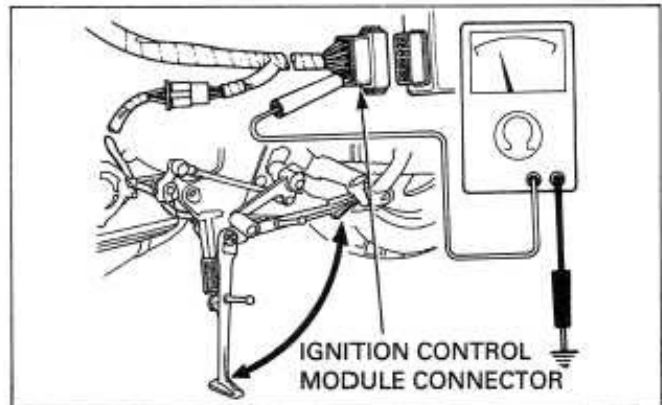

If there are any faults in above continuity check, disconnect the side stand switch connector.

Check for continuity between the wire terminals of the switch side connector.

Side stand Position	Green/white	Yellow/black	Green
Lowered		○	○
Retracted	○		○

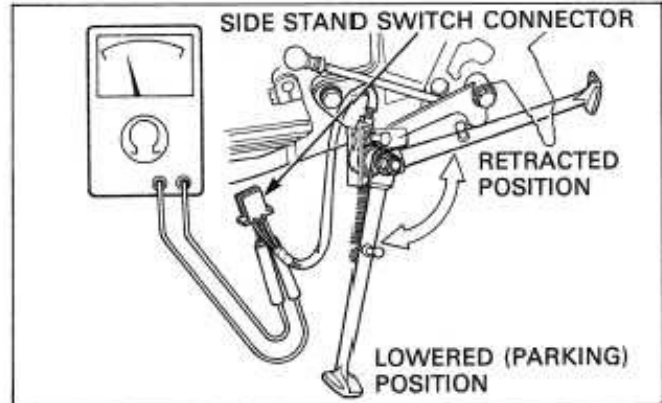

REPLACEMENT

NOTE

- The switch is installed on either the front or the rear of the side stand pivot, depending on the model.

Removal

Remove the switch attaching bolt from the side stand pivot.

Disconnect the switch wire connector from the harness and remove the switch.

NOTE

- Do not attempt to disassemble the switch because it is permanently sealed.

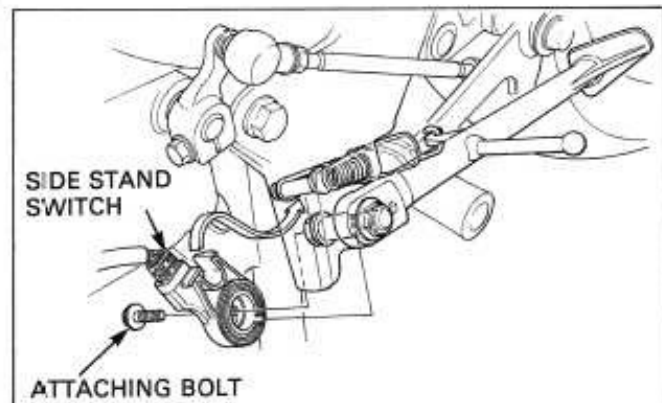

Installation

Install the switch, aligning its U-groove with the side stand return spring hook pin.
Align the lug of the switch rotor with the hole in the side stand bar pivot by moving the stand bar slightly.
While holding the switch to prevent the lug from slipping out of the hole, tighten the attaching bolt.

Route the switch wire properly and connect the connector.
Check the switch operation after installation.

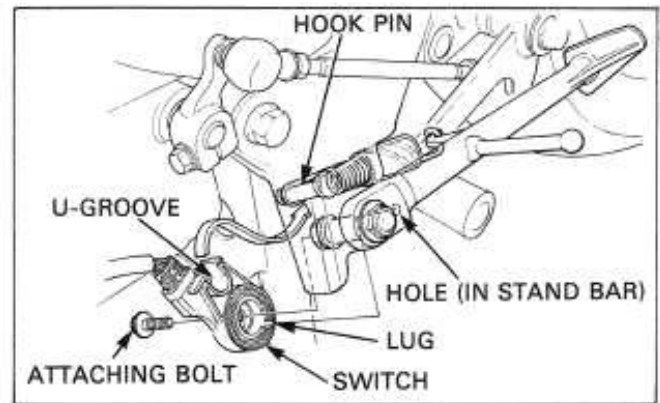

SIDE STAND INDICATOR

DESCRIPTION

When the side stand is lowered (parking position), the side stand switch detects the angle, the indicator side contact is turned ON (closed) and the indicator comes on.

When the side stand is retracted, the indicator goes off.

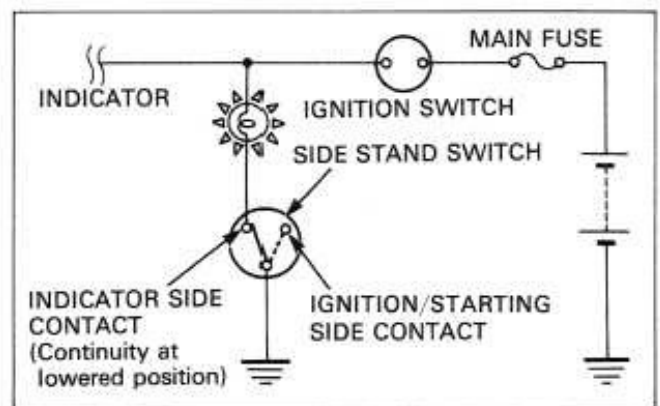

INSPECTION

Check the indicator operation by moving the side stand.

Side stand position	Indicator
Retracted	Goes off
Lowered (Parking)	Comes on

Indicator does not go off

Disconnect the side stand switch connector from the harness. Turn the ignition switch ON and check the side stand indicator.

Indicator comes on.

Indicator does not come on.

- Faulty side stand switch.

Disconnect each connector of the yellow/black wire between the bulb and side stand switch connector in order, referring to the wiring diagram, and check the indicator with the ignition switch turned ON.

Indicator goes off.

- Short circuit in the yellow/black wire between the connectorsthat causes the indicator to go off and the connector previously disconnected.

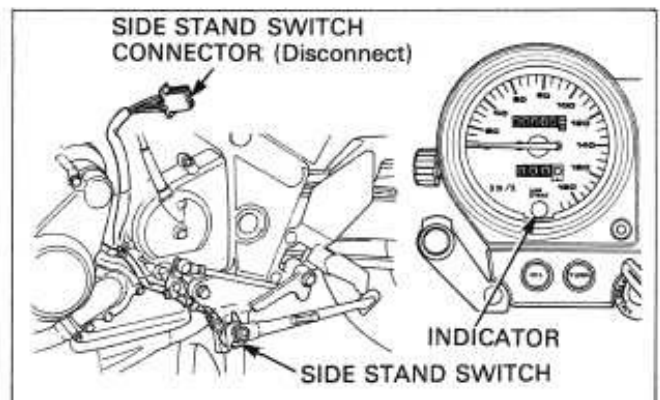
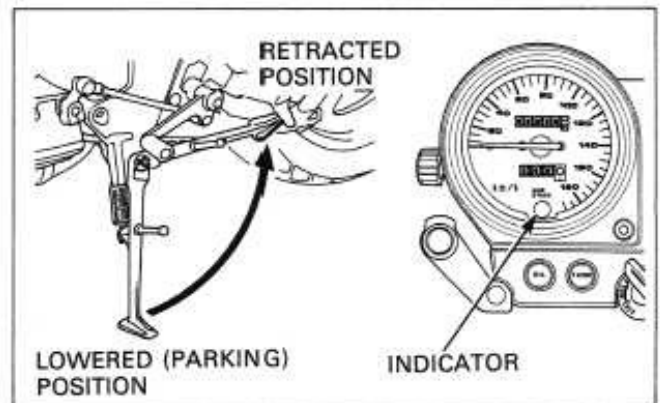

LIGHTS/METERS/SWITCHES

Indicator does not come on

Disconnect the side stand switch connector from the wire harness.

Ground the yellow/black wire terminal of the wire harness side connector to the frame. Turn the ignition switch ON and check the indicator.

Indicator does not come on.

Indicator comes on.

- Faulty side stand switch.
- Poor switch connector contact.

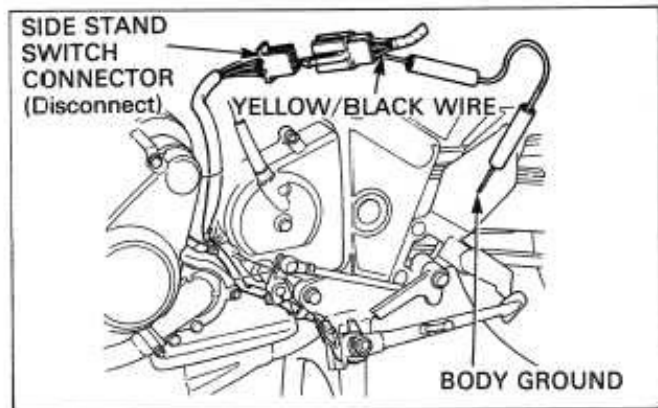

Check the voltage between the power supply (+) wire of the indicator bulb and ground with the ignition switch ON.

No voltage

Battery voltage

- Blown fuse
- Poor connector contact.
- Open circuit in power supply wire.
- Blown bulb.
- Poor contact of bulb socket.
- Open circuit between bulb and switch connector.

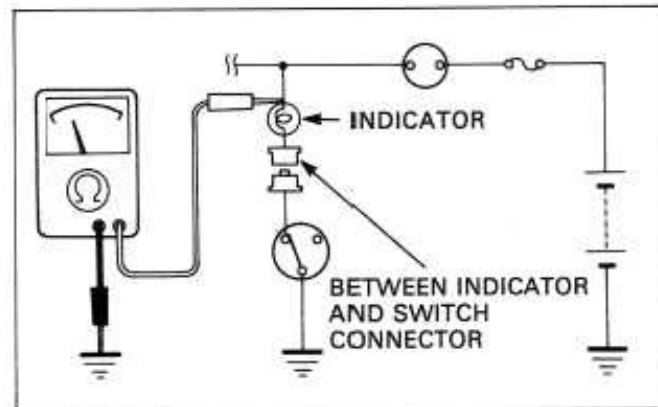

26. INDEX

ACCELERATOR PUMP	8-7	EVAPORATIVE EMISSION CONTROL SYSTEM ...	2-19
ADJUSTMENT	8-24	FAN MOTOR SWITCH	25-4
AIR CLEANER	2-6	FASTENERS	1-6
HOUSING DRAIN TUBE(off road motorcycles and ATVs)	2-7	FINAL DRIVE	15-5
AIR CUT-OFF VALVE	8-7	OIL LEVEL	2-28
ALTERNATOR	22-27	FORK	18-5
ATV WHEEL/TIRE	16-17	FUEL AUTO VALVE	8-8
BALL BEARING REPLACEMENT	1-16	GAUGE	25-7
BASIC ELECTRICAL DIAGNOSTIC METHODS ...	21-14	LINE	2-2,8-8
ELECTRONIC KNOWLEDGE	21-6	PUMP	25-9
TIRE INFORMATION	16-9	STRAINER SCREEN	2-2
BATTERY	2-29	GENERAL SAFETY	1-1
DESCRIPTIONS	22-6	HANDLEBAR (S)	18-11
REMOVAL/INSTALLATION	22-10	HEADLIGHT AIM	2-35
TESTING/CHARGING	22-11	BULB	25-11
BELT CASE AIR CLEANER	2-28	VOLTAGE INSPECTION	22-24
BRAKE FLUID	2-30	HIGH ALTITUDE ADJUSTMENT (U.S.A only) ...	8-24
LIGHT SWITCHES	2-35	HORN	25-17
PAD WEAR	2-31	HYDRAULIC CLUTCH SYSTEM SERVICE	11-27
SHOE WEAR	2-31	DISC BRAKES	17-8
BRAKE SYSTEM	2-32	TAPPETS	9-5
DESCRIPTIONS	17-2	IGNITION COIL	23-17
CAMSHAFT	9-9	SYSTEM INSPECTION (PEAK VOLTAGE MEASUREMENT METHOD)	23-13
CARBURETOR ASSEMBLY	8-14	TIMING	23-12
CHOKE	2-5	INITIAL CAMSHAFT LUBRICATION	9-19
DISASSEMBLY/INSPECTION	8-9	INSPECTION (FRAME/BODY PANELS)	20-4
IDLE SPEED	2-17	LEAK-DOWN TESTING	3-3
SYNCHRONIZATION	2-16	LOW FUEL INDICATOR	25-8
CHARGING SYSTEM DESCRIPTIONS	22-14	MECHANICAL DRUM BRAKES	17-16
INSPECTION	22-21	NUTS, BOLTS, FASTENERS	2-40
CLUTCH/DRIVEN PULLEY	12-10	OIL COOLER INSPECTION	4-12
CLUTCH INSPECTION	11-10	LEVEL INDICATOR (2-stroke engine)	25-2
SWITCH DIODE INSPECTION	24-8	OIL PRESSURE CHECK	4-9
SYSTEM	2-36	WARNING LIGHT (4-stroke engine)	25-2
COMPRESSION TESTING	3-2	OIL PUMP AND OIL LINE (2-stroke separate oil supply motorcycles)	2-4
CONNECTING ROD	14-10	DESCRIPTIONS	4-7
BEARINGS	14-8	INSPECTION	4-9
COOLANT	5-6	OIL PUMP/OIL LINE BLEEDING (2-stroke engine)	4-11
TEMPERATURE GAUGE	25-5	OUTPUT SHAFT	15-2
COOLING SYSTEM	2-18	PILOT (OR AIR) SCREW ADJUSTMENT	8-18
CRANKCASE BREATHER	2-7	PISTON/PISTON RING	10-6
CRANKSHAFT INSPECTION	14-3	PRESSURE RELIEF VALVE	4-10
MAIN BEARING	14-3	PRO-LINK SUSPENSION LINKAGE	19-11
CYLINDER	15-5	RADIATOR COOLANT	2-17
CYLINDER HEAD ASSEMBLY	9-18	REED VALVE	8-7
DISASSEMBLY	9-12	REGULATOR/RECTIFIER INSPECTION	22-22
INSPECTION	9-11	ROCKER ARM, ROCKER ARM SHAFT	9-10
CYLINDER INSTALLATION	10-10	SECONDARY AIR SUPPLY SYSTEM	2-19
DECARBONIZING (2-stroke engine)	2-15	SERVICE DATA (LUBRICATION)	4-1
DECOMPRESSOR SYSTEM	9-7	SERVICE INFORMATION	
DESCRIPTION (FRAME/BODY PANELS)	20-2	(BATTERY /CHARGING/LIGHTING SYSTEM)	22-1
DRIVE BELT	2-27, 12-5	(CLUTCH)	11-1
CHAIN	2-21	(COOLING SYSTEM)	5-1
SLIDER, CHAIN GUIDE, GUIDE		(CRANKCASE/CRANKSHAFT)	14-1
SLIDER AND ROLLERS	2-27	(CYLINDER HEAD)	9-1
DRIVE PULLEY	12-6	(CYLINDER/PISTON)	10-1
ELECTRICAL SYMBOLS	21-13	(ELECTRIC STARTER/STARTER CLUTCH)	24-1
EMISSION CONTROL INFORMATION LABELS ...	7-9		
ENGINE OIL	2-11		
ENGINE OIL FILTER	2-13		
SCREEN	2-14		

INDEX

(ELECTRICAL FUNDAMENTALS)	21-1	(BRAKES)	17-1
(EMISSION CONTROL SYSTEMS)	7-1	(CLUTCH)	11-1
(ENGINE TESTING)	3-1	(COOLING SYSTEM)	5-1
(EXHAUST SYSTEM)	6-1	(CRANKCASE/CRANKSHAFT)	14-1
(FINAL DRIVE/OUTPUT SHAFT)	15-1	(CYLINDER HEAD)	9-1
(FRAME/BODY PANELS)	20-1	(CYLINDER/PISTON)	10-1
(FRONT SUSPENSION)	18-1	(ELECTRIC STARTER/STARTER CLUTCH)	24-1
(FUEL SYSTEM)	8-1	(EMISSION CONTROL SYSTEMS)	7-1
(IGNITION SYSTEMS)	23-1	(ENGINE TESTING)	3-1
(LIGHTS/METERS/SWITCHES)	25-1	(EXHAUST SYSTEM)	6-1
(LUBRICATION)	4-1	(FINAL DRIVE/OUTPUT SHAFT)	15-1
(REAR SUSPENSION)	19-1	(FRAME/BODY PANELS)	20-1
(TRANSMISSION)	13-1	(FRONT SUSPENSION)	18-1
(V-MATIC BELT DRIVE SYSTEM)	12-1	(FUEL SYSTEM)	8-2
(WHEELS/TIRES)	16-1	(IGNITION SYSTEMS)	23-1
SERVICE RULES	1-3	(LUBRICATION)	4-2
SHOCK ABSORBER	19-7	(REAR SUSPENSION)	19-1
SIDE STAND	2-37	(TRANSMISSION)	13-1
IGNITION CUT-OFF SWITCH	23-19	(V-MATIC BELT DRIVE SYSTEMS)	12-1
SPARK ARRESTER (U.S.A. only)	2-40	(WHEELS/TIRES)	16-1
PLUG	2-8	TURN SIGNAL LIGHTS	25-16
TEST	23-11	VALVE CLEARANCE	2-9
STARTER CLUTCH INSPECTION	24-8	GUIDES	9-13
MOTOR	24-3	SEATS	9-15
PINION INSPECTION	24-9	SPRINGS	9-12
RELAY SWITCH	24-6	VALVES	9-12
STEERING HEAD BEARINGS	2-43	WATER PUMP	5-8
STEM	18-15	WHEEL ALIGNMENT (FOUR TRAX)	2-43
SUSPENSION	2-38	BALANCING	16-17
SWINGARM	19-11	BEARING REPLACEMENT	16-8
SWITCHES	25-12	REMOVAL/INSTALLATION	16-2
SYSTEM DESCRIPTIONS		WHEELS/TIRES	2-41
(CLUTCH)	11-2		
(COOLING SYSTEM)	5-2		
(CRANKCASE/CRANKSHAFT)	14-2		
(CYLINDER HEAD)	9-2		
(CYLINDER/PISTON)	10-2		
(EMISSION CONTROL SYSTEMS)	7-2		
(EXHAUST SYSTEM)	6-2		
(FINAL DRIVE/OUTPUT SHAFT)	15-2		
(FRONT SUSPENSION)	18-2		
(FUEL SYSTEM)	8-3		
(IGNITION SYSTEMS)	23-4		
(LUBRICATION)	4-3		
(REAR SUSPENSION)	19-2		
(TRANSMISSION)	13-2		
(V-MATIC BELT DRIVE SYSTEM)	12-2		
SYSTEM INSPECTIONS (EMISSION CONTROL SYSTEMS)	7-5		
SYSTEM TESTING (COOLING SYSTEM)	5-7		
THERMOSTAT	5-8		
THROTTLE OPERATION	2-3		
TIRE INSTALLATION	16-14		
REMOVAL	16-11		
TRANSMISSION ASSEMBLY	13-7		
DISASSEMBLY	13-6		
INSPECTION	13-6		
OIL (2-stroke engine)	2-20		
TROUBLESHOOTING			
(BATTERY/CHARGING/LIGHTING SYSTEM)	22-3		

A Few Words About Safety

Service information

The service and repair information contained in this manual is intended for use by qualified, professional technicians. Attempting service or repairs without the proper training, tools, and equipment could cause injury to you or others. It could also damage the vehicle or create an unsafe condition.

This manual describes the proper methods and procedures for performing service, maintenance, and repairs. Some procedures require the use of specially designed tools and dedicated equipment. Any person who intends to use a replacement part, service procedure or a tool that is not recommended by Honda, must determine the risks to their personal safety and the safe operation of the vehicle.

If you need to replace a part, use genuine Honda parts with the correct part number or an equivalent part. We strongly recommended that you do not use replacement parts of inferior quality.

For Your Customer's Safety

Proper service and maintenance are essential to the customer's safety and the reliability of the vehicle. Any error or oversight while servicing a vehicle can result in faulty operation, damage to the vehicle, or injury to others.

⚠ WARNING

Improper service or repairs can create an unsafe condition that can cause your customer or others to be seriously hurt or killed.

Follow the procedures and precautions in this manual and other service materials carefully.

For Your Safety

Because this manual is intended for the professional service technician, we do not provide warnings about many basic shop safety practices (e. g., Hot parts - wear gloves). If you have not received shop safety training or do not feel confident about your knowledge of safe servicing practice, we recommended that you do not attempt to perform the procedures described in this manual.

Some of the most important general service safety precautions are given below. However, we cannot warn you of every conceivable hazard that can arise in performing service and repair procedures. Only you can decide whether or not you should perform a given task.

⚠ WARNING

Failure to properly follow instructions and precautions can cause you to be seriously hurt or killed.

Follow the procedures and precautions in this manual carefully.

Important Safety Precautions

Make sure you have a clear understanding of all basic shop safety practices and that you are wearing appropriate clothing and using safety equipment. When performing any service task, be especially careful of the following:

- Read all of the instructions before you begin, and make sure you have the tools, the replacement or repair parts, and the skills required to perform the tasks safely and completely.
- Protect your eyes by using proper safety glasses, goggles or face shields any time you hammer, drill, grind, pry or work around pressurized air or liquids, and springs or other stored-energy components. If there is any doubt, put on eye protection.

- Use other protective wear when necessary, for example gloves or safety shoes. Handling hot or sharp parts can cause severe burns or cuts. Before you grab something that looks like it can hurt you, stop and put on gloves.
- Protect yourself and others whenever you have the vehicle up in the air. Any time you lift the vehicle, either with a hoist or a jack, make sure that it is always securely supported. Use jack stands.

Make sure the engine is off before you begin any servicing procedures, unless the instruction tells you to do otherwise. This will help eliminate several potential hazards:

- Injury from moving parts. If the instruction tells you to run the engine, be sure your hands, fingers and clothing are out of the way.

Gasoline vapors and hydrogen gases from batteries are explosive. To reduce the possibility of a fire or explosion, be careful when working around gasoline or batteries.

- Use only a nonflammable solvent, not gasoline, to clean parts.
- Never drain or store gasoline in an open container.
- Keep all cigarettes sparks and flames away from the battery and all fuel-related parts.

Your safety, and the safety of others, is very important. To help you make informed decisions we have provided safety messages and other information throughout this manual. Of course, it is not practical or possible to warn you about all the hazards associated with servicing this vehicle. You must use your own good judgment.

You will find important safety information in a variety of forms including:

- Safety Labels - on the vehicle
- Safety Messages preceded by a safety alert symbol  and one of three signal words, DANGER, WARNING, or CAUTION. These signal words mean:

DANGER

You WILL be KILLED or SERIOUSLY HURT if you don't follow instructions.

WARNING

You CAN be KILLED or SERIOUSLY HURT if you don't follow instructions.

CAUTION

You CAN be HURT if you don't follow instructions.

- Instructions - on how to service this vehicle correctly and safely.

As you read this manual, you will find information that is preceded by a **NOTICE** symbol. The purpose of this message is to help prevent damage to your vehicle, other property, or the environment.

ALL INFORMATION, ILLUSTRATIONS, DIRECTIONS AND SPECIFICATIONS INCLUDED IN THIS PUBLICATION ARE BASED ON THE LATEST PRODUCT INFORMATION AVAILABLE AT THE TIME OF APPROVAL FOR PRINTING. HONDA MOTOR CO., LTD. RESERVES THE RIGHT TO MAKE CHANGES AT ANY TIME WITHOUT NOTICE AND WITHOUT INCURRING ANY OBLIGATION WHATEVER. NO PART OF THIS PUBLICATION MAY BE REPRODUCED WITHOUT WRITTEN PERMISSION. THIS MANUAL IS WRITTEN FOR PERSONS WHO HAVE ACQUIRED BASIC KNOWLEDGE OF MAINTENANCE ON HONDA MOTORCYCLES, MOTOR SCOOTERS OR ATVS.

HONDA MOTOR CO., LTD.
SERVICE PUBLICATION OFFICE

HOW TO USE THIS MANUAL

This manual explains the theory of operation of the various systems common to HONDA motorcycles and motor scooters and ATVs. It also provides basic information on troubleshooting, inspection and repair of components and systems found on these machines.

Refer to the Model Specific Service Manual for adjustments, maintenance and repair information specific to the model you are servicing.

Section 1 provides general information on the whole motorcycle as well as Warnings and Cautions to remember when performing maintenance and repairs.

Sections 2 through 15 cover all aspects of the engine and drive train.

Sections 16 through 20 include all of the component groups that make up the chassis.

Section 21 through 25 apply to the various electrical components and systems found on Honda motorcycles.

An extensive alphabetized Index provides rapid access to information on specific components or systems.

All information, illustrations, directions and specifications included in this publication are based on the latest product information available at the time of approval for printing. Honda Motor Co., LTD. reserves the right to make changes at any time without notice and without incurring any obligation whatever. No part of this publication may be reproduced without written permission.













HONDA MOTOR CO., LTD.
Service Publications Office

CONTENTS

	GENERAL INFORMATION	1
	MAINTENANCE	2
ENGINE AND DRIVE TRAIN	ENGINE TESTING	3
	LUBRICATION	4
	COOLING SYSTEM	5
	EXHAUST SYSTEM	6
	EMISSION CONTROL SYSTEMS	7
	FUEL SYSTEM	8
	CYLINDER HEAD/VALVES	9
	CYLINDER/PISTON	10
	CLUTCH	11
	V-MATIC BELT DRIVE SYSTEM	12
	TRANSMISSION/GEARSHIFT LINKAGE	13
	CRANKCASE/CRANKSHAFT	14
	FINAL DRIVE/OUTPUT SHAFT	15
CHASSIS	WHEELS/TIRES	16
	BRAKES	17
	FRONT SUSPENSION/STEERING	18
	REAR SUSPENSION	19
	FRAME/BODY PANELS	20
ELECTRICAL	ELECTRICAL FUNDAMENTALS	21
	BATTERY/CHARGING/LIGHTING SYSTEM	22
	IGNITION SYSTEMS	23
	ELECTRIC STARTER/STARTER CLUTCH	24
	LIGHTS/METERS/SWITCHES	25
	INDEX	26

Symbols

These symbols used throughout this manual show specific service procedures. If supplementary information is required pertaining to these symbols, it would be explained specifically in the text without the use of the symbols.

	Use recommended engine oil, unless otherwise specified.
	Use molybdenum solution (mixture of the engine oil and molybdenum grease with the ratio 1 : 1).
	Use multi-purpose grease (Lithium based multi-purpose grease NLGI #2 or equivalent)
	Use molybdenum disulfide grease (containing more than 3% molybdenum disulfide, NLGI #2 or equivalent) Example: Molykote® BR-2 plus manufactured by Dow Corning, U.S.A. Multi-purpose M-2 manufactured by Mitsubishi Oil Japan
	Use molybdenum disulfide paste (containing more than 40% molybdenum disulfide, NLGI #2 or equivalent) Example: Molykote® G-n Paste manufactured by Dow Corning, U.S.A. Hond Moly 60 (U.S.A. only) Rocol ASP manufactured by Rocol Limited, U.K. Rocol Paste manufactured by Sumico Lubricant, Japan
	Use silicone grease
	Apply locking agent. Use a middle-strength thread locking agent unless otherwise specified.
	Apply sealant.
	Replace the part(s) with new one(s) before assembly.
	Use brake fluid, DOT 3 or DOT 4. Use the recommended brake fluid, unless otherwise specified.
	Use Pro Honda Suspension Fluid.
	Use special tool
	Use optional tool. These tools are obtained the same way you order parts.