



SERVICE INFORMATION	20-1	HANDLEBAR SWITCHES	20-3
OIL PRESSURE WARNING SWITCH	20-2	IGNITION SWITCH	20-5
BRAKE SWITCHES	20-2	CLUTCH SWITCH	20-5
NEUTRAL SWITCH	20-2		

## SERVICE INFORMATION

### GENERAL

- Some wires have different colored bands around them near the connector. These are connected to other wires which correspond with the band color.
- All plastic plugs have locking tabs that must be released before disconnecting, and must be aligned when reconnecting.
- The following color codes used are indicated throughout this section and on the wiring diagram.

<b>B</b> = Blue	<b>G</b> = Green	<b>LG</b> = Light Green	<b>R</b> = Red
<b>Bk</b> = Black	<b>Gr</b> = Grey	<b>O</b> = Orange	<b>W</b> = White
<b>Br</b> = Brown	<b>LB</b> = Light Blue	<b>P</b> = Pink	<b>Y</b> = Yellow

- To isolate an electrical failure, check the continuity of the electrical path through the part. A continuity check can usually be made without removing the part from the motorcycle. Simply disconnect the wires and connect a continuity tester or volt-ohmmeter to the terminals or connections.
- A continuity tester is useful when checking to find out whether or not there is an electrical connection between two points. An ohmmeter is needed to measure the resistance of a circuit, as when there is a specific coil resistance involved, or when checking for high resistance by corroded connections.



**SWITCHES**

**OIL PRESSURE WARNING SWITCH**

Check for continuity while applying pressure to the switch. Replace the switch if necessary.  
Apply a liquid sealant to the switch threads.

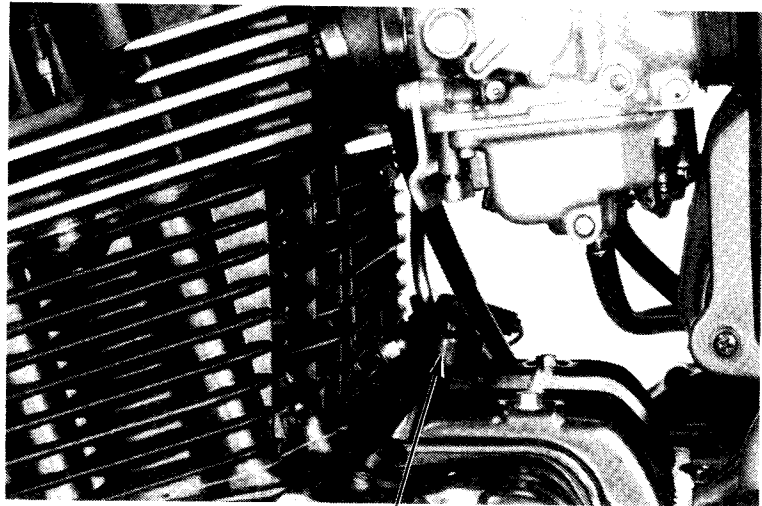

**OIL PRESSURE WARNING SWITCH**

**BRAKE SWITCHES**

Check the rear brakelight switch for continuity with the rear brake applied.

Check the front brakelight switch for continuity with the front brake applied.

Replace the switches if necessary.

**FRONT**

**REAR**

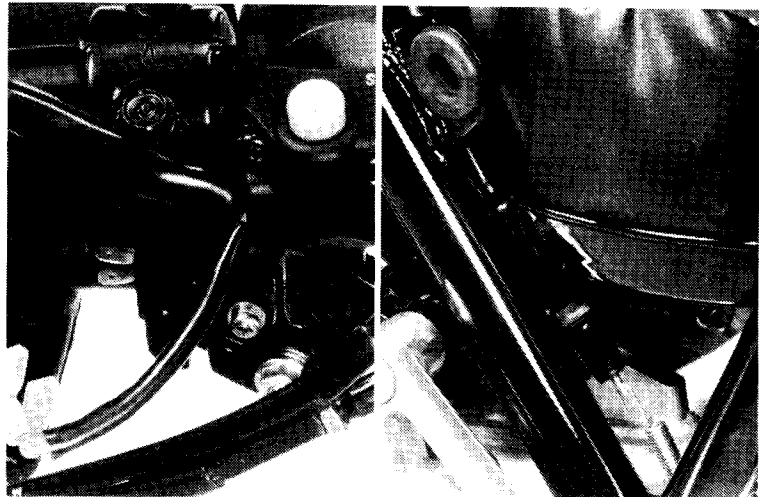

**BRAKE APPLIED: CONTINUITY**  
**BRAKE NOT APPLIED: NO CONTINUITY**  
**NEUTRAL SWITCH**

**NEUTRAL SWITCH**

Remove the foot pegs, gearshift pedal and left rear crankcase cover.

Check the switch for continuity between the switch terminal (wire removed) and ground with the transmission in neutral and with the transmission in any gear.

Replace the neutral switch if necessary.

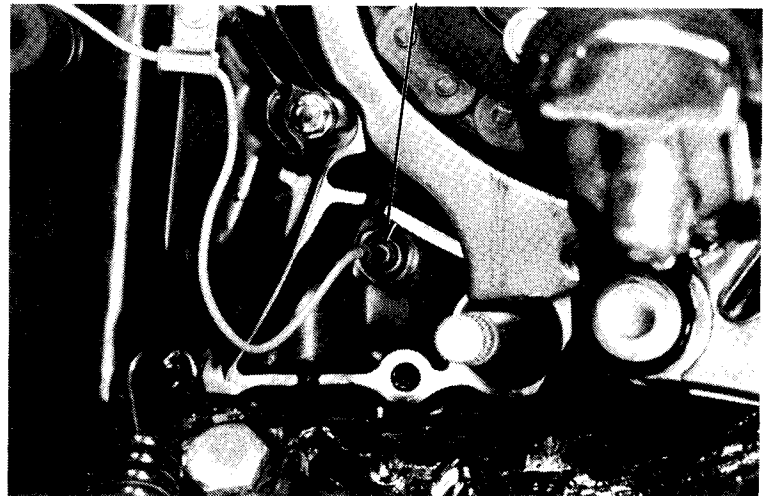

**IN NEUTRAL: CONTINUITY**  
**IN ANY GEAR: NO CONTINUITY**



## HANDLEBAR SWITCHES

Remove the fairing and head light (page 14-3).

The handlebar cluster switches (lights, turn signals, horn) must be replaced as assemblies.

Continuity tests for the components of the handlebar cluster switches follow:

Continuity should exist between the color coded wires on each chart.

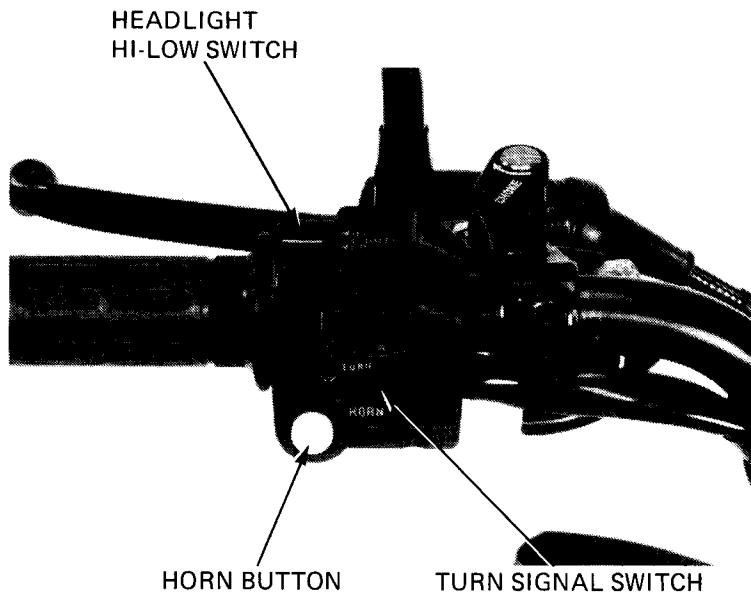

L HANDLEBAR SWITCH COUPLER

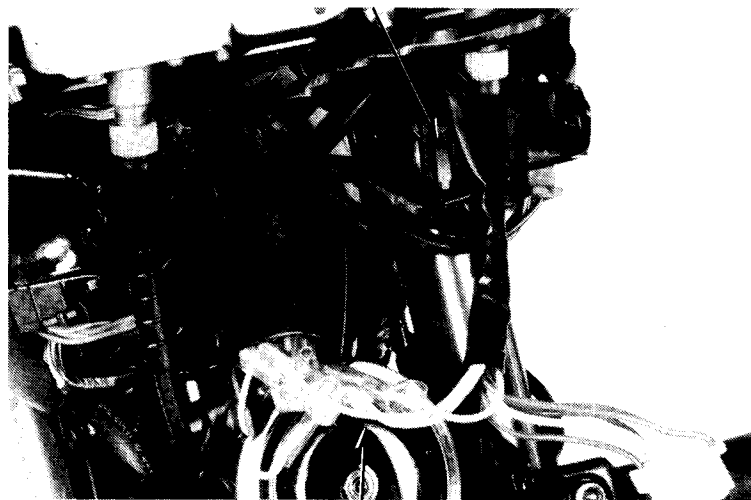

L HANDLEBAR SWITCH CONNECTORS

### HEADLIGHT HI-LOW SWITCH

**HI:** B/W to B  
**MIDDLE (N):** B/W to W to B  
**LO:** B/W to W

#### Headlight Hi-Low Switch

	HL	Hi	Lo
Hi	○ — ○		
(N)	○ — ○ — ○		
Lo	○ — ○		
Code Color	B/W	B	W

### TURN SIGNAL SWITCH

**LEFT:** Gr to O, Br/W to LB/W  
**OFF:** No continuity  
**RIGHT:** Gr to LB, Br/W to O/W

#### Turn Signal Switch

	W	L	R
LEFT	○ — ○		
OFF			
RIGHT	○ — ○		
Code color	Gr	O	LB

### HORN BUTTON

LG to G with button depressed  
No continuity with button released

#### Horn Button

	Ho	E
Code color	LG	G



**SWITCHES**

**STARTER BUTTON**

Bk to Y/R with button depressed

**Starter Button**

	BAT <sub>2</sub>	ST
FREE (OUT)		
START		
Code color	Bk	Y/R

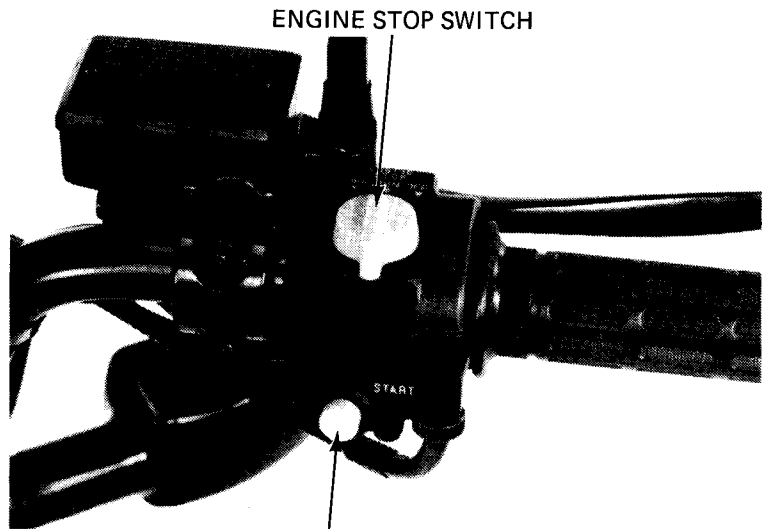

STARTER BUTTON

**ENGINE STOP SWITCH**

RUN: Bk to Bk/w  
OFF: No continuity

**Engine Stop Switch**

	BAT <sub>2</sub>	IG
OFF		
RUN		
OFF		
Code color	Bk	Bk/W

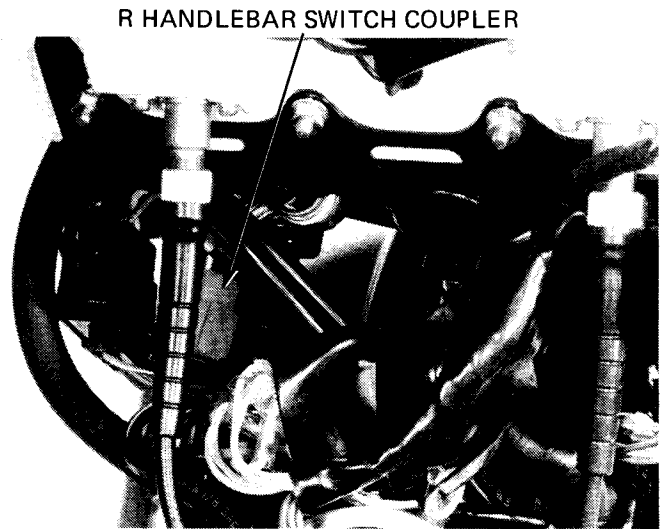

R HANDLEBAR SWITCH COUPLER



### IGNITION SWITCH

Remove the instrument cluster (page 14-4) and disconnect the coupler.

Remove the ignition switch.

Check continuity of terminals on the ignition switch in each switch position.

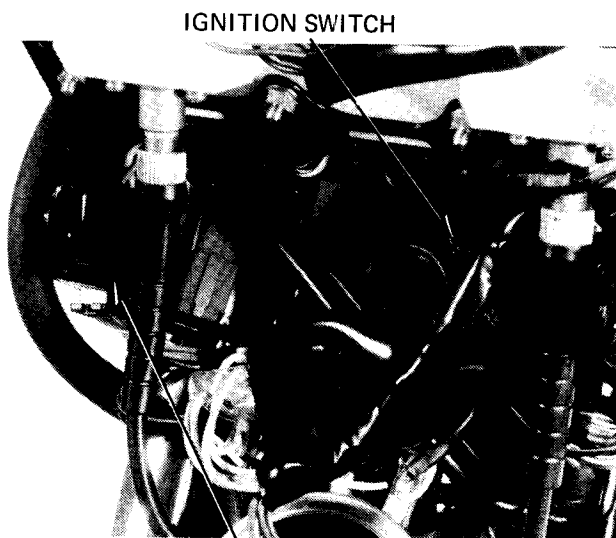

IGNITION SWITCH COUPLER

### SWITCH POSITION

LOCK: No continuity  
 OFF: No continuity  
 ON: BAT<sub>1</sub> to IG, TL<sub>1</sub> to TL<sub>2</sub>  
 PARK: PA to BAT<sub>1</sub>

Terminal Position	PA	BAT <sub>1</sub>	IG	TL <sub>1</sub>	TL <sub>2</sub>
P	○—○				
ON		○—○	○—○	○—○	
OFF					
LOCK					

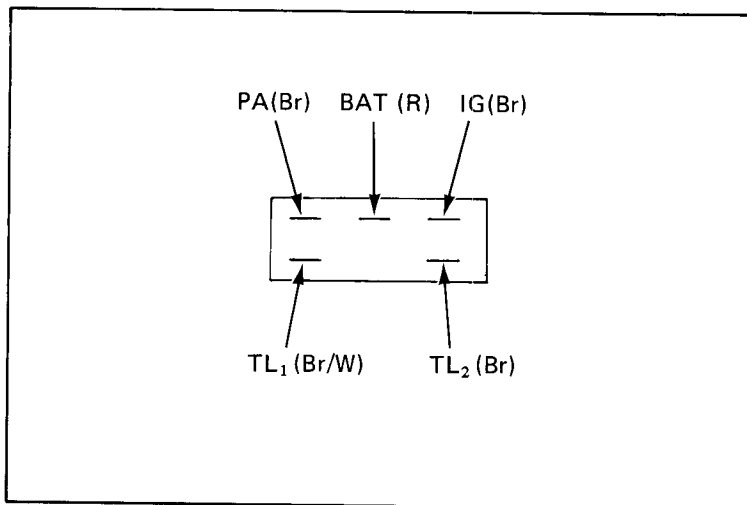

### CLUTCH SWITCH

Check continuity of the clutch lever (safety) switch with the clutch released and applied.  
Replace if necessary.

#### REMOVAL

Unplug the wires.

Remove the clutch lever and cable.

Remove the switch.

#### NOTE:

The switch case has a small protrusion that must point toward the handlebar when installed.

### CLUTCH SWITCH

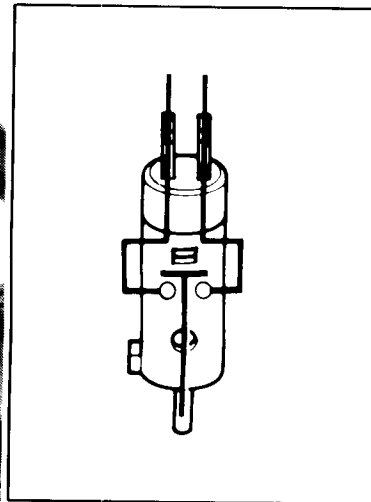

CLUTCH APPLIED: CONTINUITY  
CLUTCH RELEASED: NO CONTINUITY