



# 19. ELECTRIC STARTER

|                      |      |
|----------------------|------|
| SERVICE INFORMATION  | 19-1 |
| TROUBLESHOOTING      | 19-1 |
| STARTER MOTOR        | 19-2 |
| STARTER RELAY SWITCH | 19-5 |
| DIODE/RECTIFIER      | 19-6 |

## SERVICE INFORMATION

### GENERAL

- The starter motor can be removed with the engine in the frame.

### SPECIFICATIONS

|               |                      | STANDARD                      | SERVICE LIMIT    |
|---------------|----------------------|-------------------------------|------------------|
| Starter motor | Brush spring tension | 560 g—680 g (19.75—23.89 oz)  | 560 g (19.75 oz) |
|               | Brush length         | 12.0 – 13.0 mm (0.47—0.51 in) | 7.5 mm (0.03 in) |

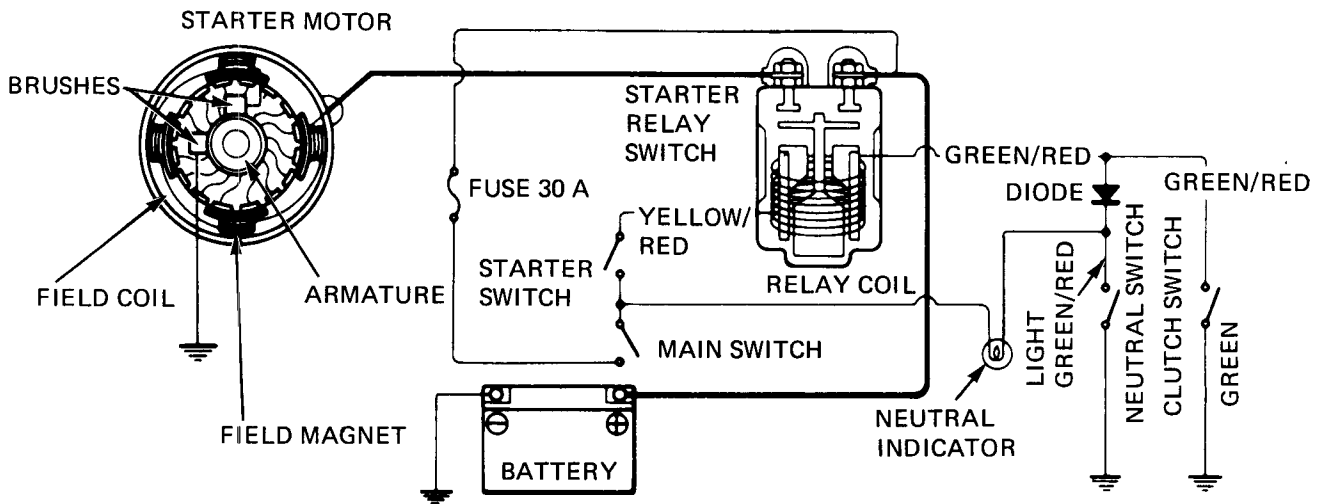

**19**

## TROUBLESHOOTING

### Starter motor will not turn:

- Battery discharged
- Faulty ignition switch
- Faulty starter switch
- Faulty neutral switch
- Faulty starter relay switch
- Loose or disconnected wire or cable
- Neutral diode open

### Starter motor turns engine slowly

- Low specific gravity
- Excessive resistance in circuit
- Binding in starter motor

### Starter motor turns, but engine does not turn:

- Faulty starter clutch
- Faulty starter motor gears
- Faulty starter motor or idle gear

### Starter motor and engine turns, but engine does not start

- Faulty ignition system
- Engine problems



## STARTER MOTOR

### REMOVAL

**WARNING**

*With the ignition switch OFF, remove the negative cable at the battery before servicing the starter motor.*

Remove the starter motor cover and left crankcase rear cover.

Disconnect the starter cable at the starter motor.

Remove the starter motor mounting bolts and the starter motor.

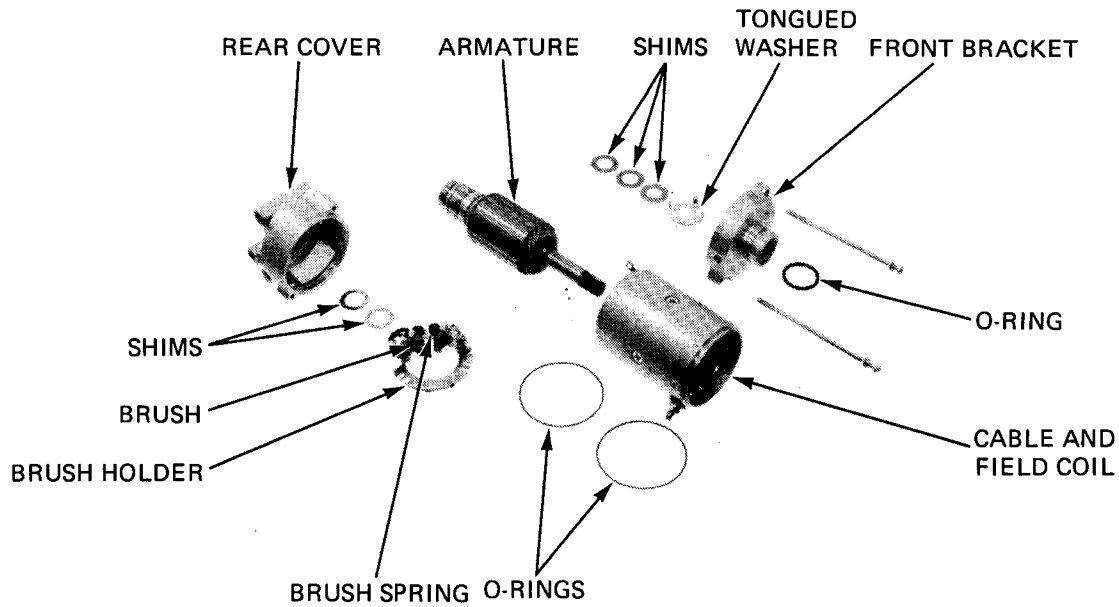
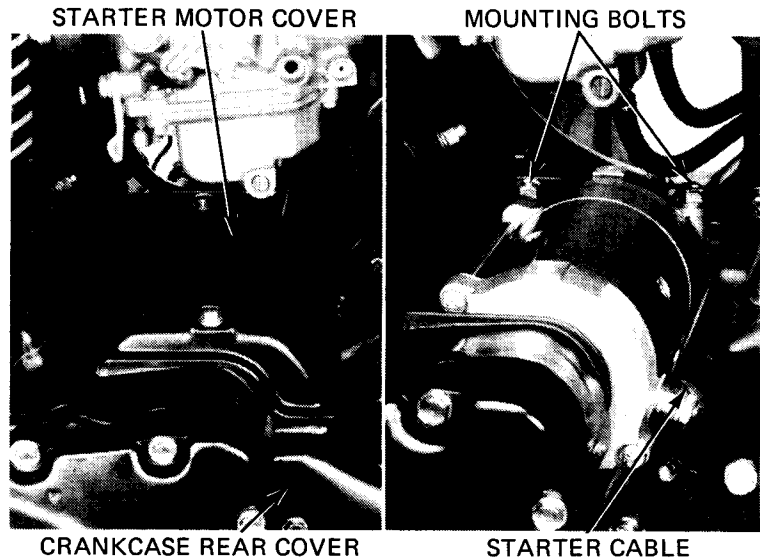



### BRUSH INSPECTION

Remove the starter motor case screws.

Inspect the brushes and measure the brush length.

Measure brush spring tension with a spring scale.

#### SERVICE LIMITS:

Brush length: 7.5 mm (0.30 in)

Brush spring tension: 560 g (19.75 oz)

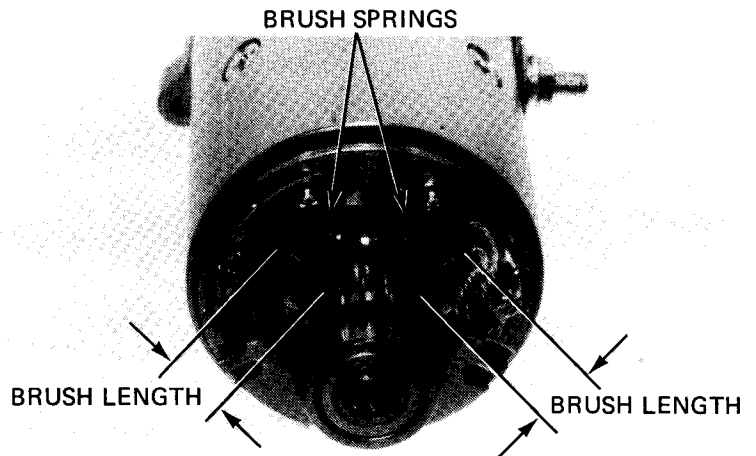

### COMMUTATOR INSPECTION

Remove the starter motor case.

#### NOTE:

Record the location and number of thrust washers.

Inspect the commutator bars for discoloration.

Bars discolored in pairs indicate grounded armature coils.

#### NOTE:

Do not use emery or sand paper on the commutator.

Check for continuity between pairs of commutator bars, and also between commutator bars and armature shaft.

#### COMMUTATOR

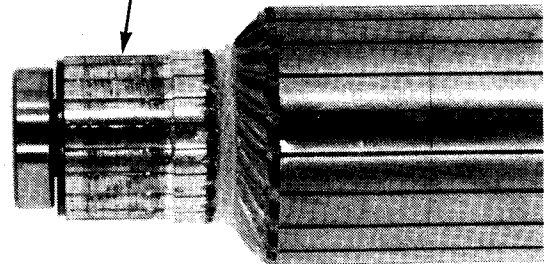

COMMUTATOR BAR PAIRS  
CONTINUITY: NORMAL

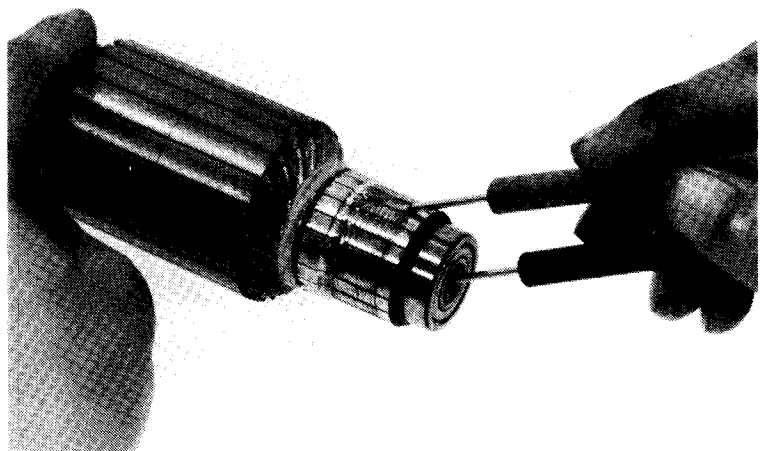

ARMATURE SHAFT-COMMUTATOR BARS  
NO CONTINUITY: NORMAL



**ELECTRIC STARTER**

**FIELD COIL INSPECTION**

Check for continuity from the cable terminal to the motor case and from the cable terminal to the brush wire.

Replace the starter motor if the field coil is not continuous or if it is shorted to the motor case.

**CABLE TERMINAL-MOTOR CASE  
NO CONTINUITY: NORMAL**

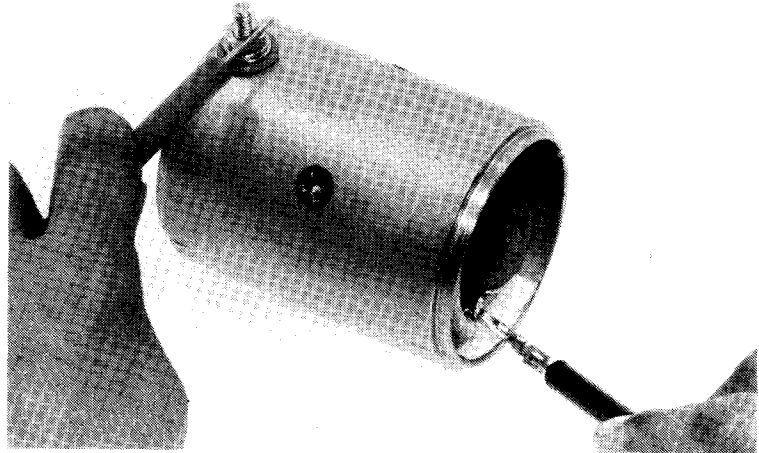

**CABLE TERMINAL-BRUSH WIRE  
CONTINUITY: NORMAL**

**ASSEMBLY/INSTALLATION**

Install the front bracket into the starter motor case aligning the index marks.

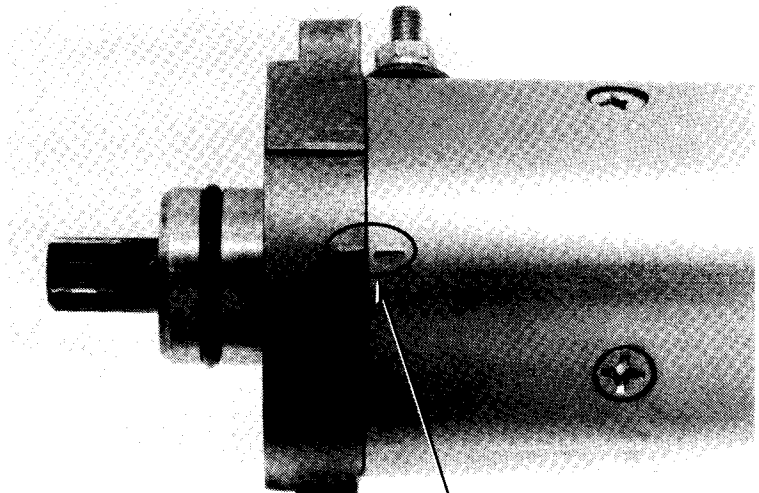

**INDEX MARKS**

Assemble the starter motor.

Align the case notch with the brush holder pin.

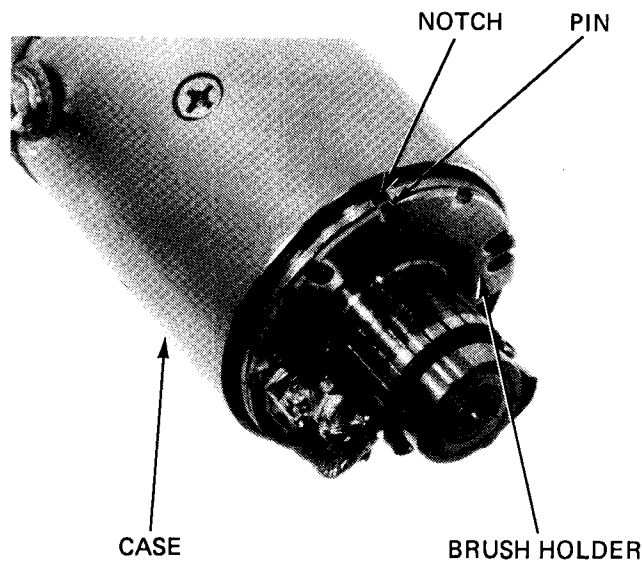



Install the rear cover aligning its slot with the brush holder pin.

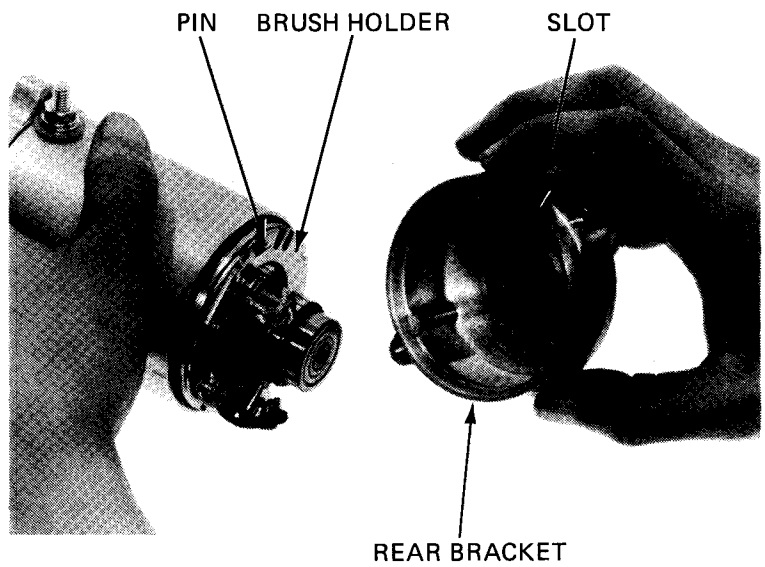

## STARTER RELAY SWITCH

### INSPECTION

Depress the starter switch button with the ignition ON.

The coil is normal if the starter relay switch clicks.

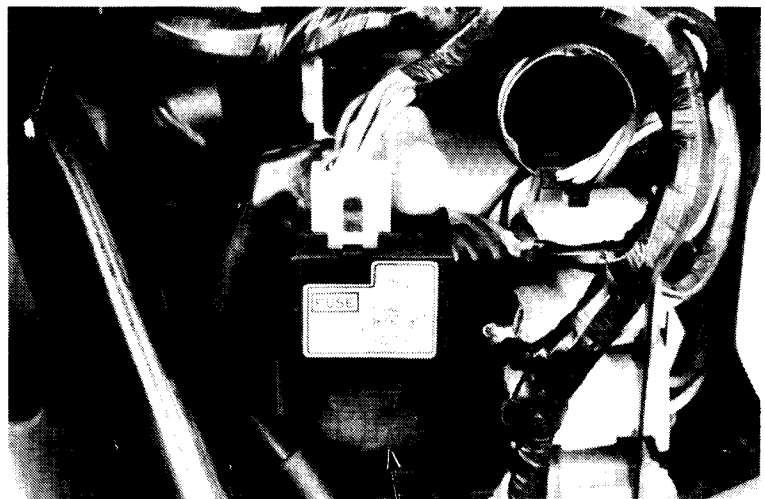

STARTER RELAY

Connect an ohmmeter to the starter relay switch terminals.

Connect a 12 V battery to the switch cable terminals.

The switch is normal if there is continuity.

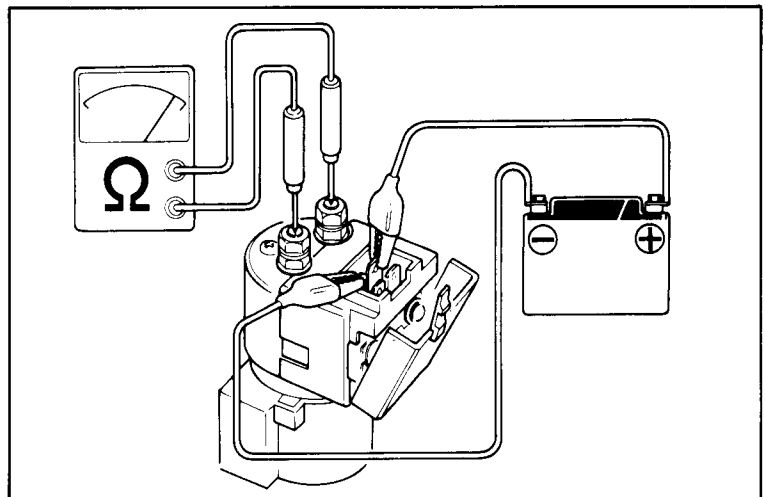



**ELECTRIC STARTER**

**DIODE/RECTIFIER**

**REMOVAL**

Remove the left side cover.

Remove the diode from the wire harness.

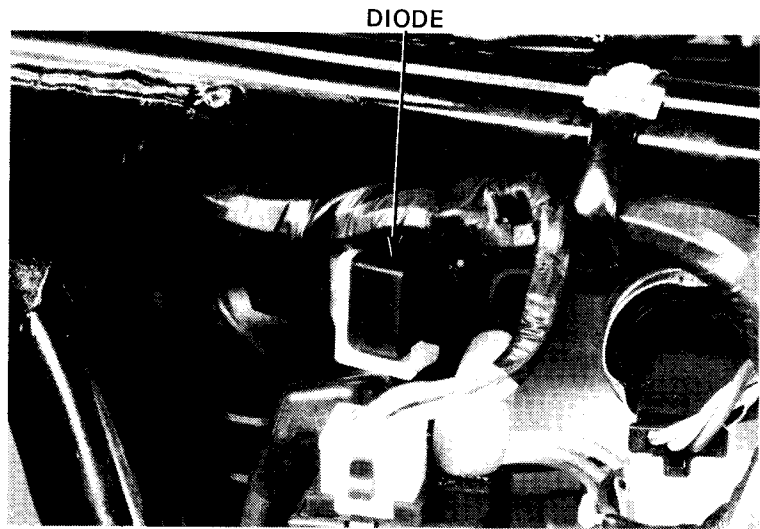

**INSPECTION**

Check for continuity with an ohmmeter.

|                    |               |
|--------------------|---------------|
| NORMAL DIRECTION:  | CONTINUITY    |
| REVERSE DIRECTION: | NO CONTINUITY |

