



SERVICE INFORMATION	15-1
TROUBLESHOOTING	15-1
REAR WHEEL	15-2
SHOCK ABSORBER	15-9
SWING ARM	15-12

## SERVICE INFORMATION

### GENERAL

- The rear wheel uses a tubeless tire. For tubeless tire repairs, refer to the Tubeless Tire Manual.
- Never ride on the rim or try to bend the rim.

### SPECIFICATIONS

		Standard	Service Limit
Axle runout		—	0.2 mm (0.01 in)
Rear wheel runout	Radial	—	2.0 mm (0.08 in)
	Axial	—	2.0 mm (0.08 in)
Shock absorber spring free length		238.0 mm (9.37 in)	233.0 mm (9.17 in)
Swing arm bushing	I.D.	21.500-21.552 mm (0.8465-0.8485 in)	21.7 mm (0.854 in)
Swing arm collar	O.D.	21.427-21.460 mm (0.8436-0.8449 in)	21.4 mm (0.843 in)

### TORQUE VALUES

Rear brake disc	30-35 N·m (3.0-3.5 kg-m, 22-26 ft-lb)
Driven sprocket	80-100 N·m (8.0-10.0 kg-m, 58-72 ft-lb)
Rear axle nut	80-100 N·m (8.0-10.0 kg-m, 58-72 ft-lb)
Rear shock absorber	30-40 N·m (3.0-4.0 kg-m, 22-29 ft-lb)
Swing arm pivot nut	60-70 N·m (6.0-7.0 kg-m, 43-51 ft-lb)
Brake torque link	18-25 N·m (1.8-2.5 kg-m, 13-18 ft-lb)

**15**

### TOOLS

#### Special

Bearing remover (U.S.A. only)	M9310-277-91774
Attachment (U.S.A. only)	M9310-277-91775

#### Common

Driver	07749-0010000 or 07949-6110000
Attachment, 62 x 68 mm	07746-0010500
Attachment, 52 x 55 mm	07746-0010400
Pilot, 20 mm	07746-0040500
Pilot, 25 mm	07746-0040600
Rear shock absorber compressor	07959-3290001

## TROUBLESHOOTING

#### Oscillation

1. Bent rim
2. Loose wheel bearings
3. Faulty tire
4. Loose axle
5. Tire pressure incorrect
6. Swingarm bearing worn

#### Soft suspension

1. Weak springs
2. Shock absorber improperly adjusted

#### Hard suspension

1. Shock absorber improperly adjusted
2. Bent shock absorber

#### Suspension noise

1. Shock case binding
2. Loose fasteners



**REAR WHEEL/SUSPENSION**

**REAR WHEEL**

**REMOVAL**

Place the motorcycle on its center stand.  
Loosen the drive chain adjuster lock nuts.  
Loosen the adjuster nuts.

Remove the rear axle nut and axle.

Push the wheel forward and remove the drive chain from the sprocket.

Pull the wheel out of the swingarm.

**NOTE:**

Do not operate the rear brake pedal after removing the rear wheel. To do so will cause difficulty in refitting the brake disc between the brake pads.

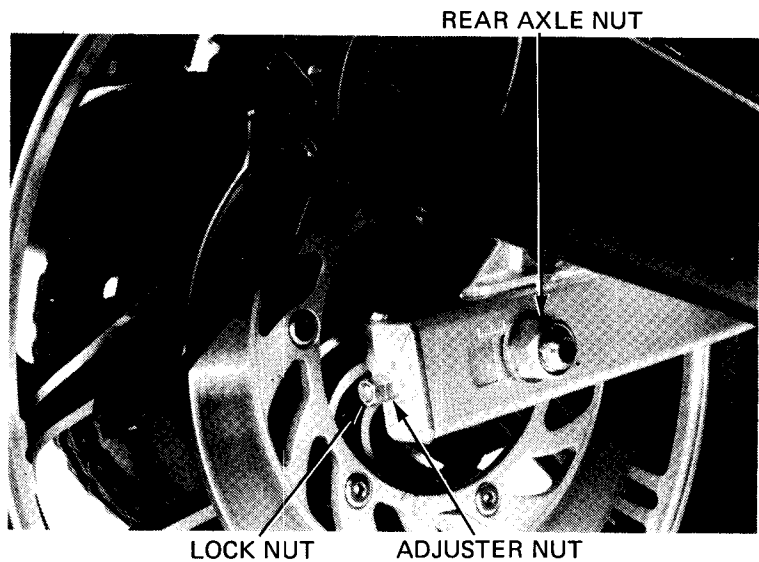

**DISASSEMBLY**

Remove the rear disc bolts and the disc.

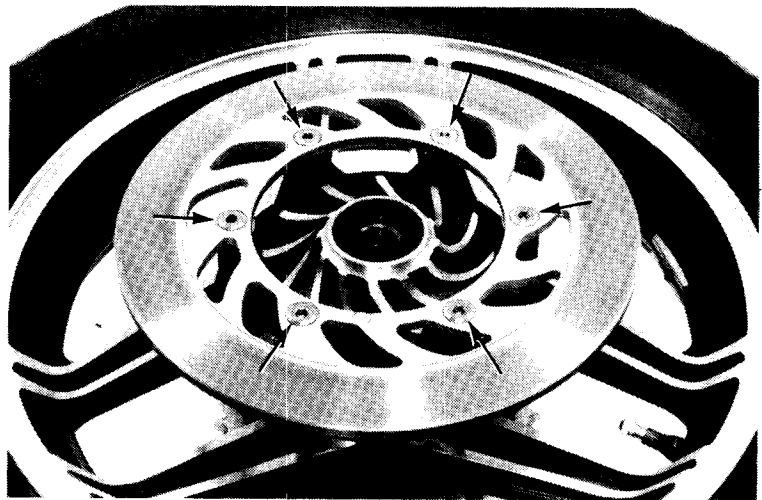

Loosen the driven sprocket nuts.  
Remove the driven flange from the wheel hub and the driven sprocket.

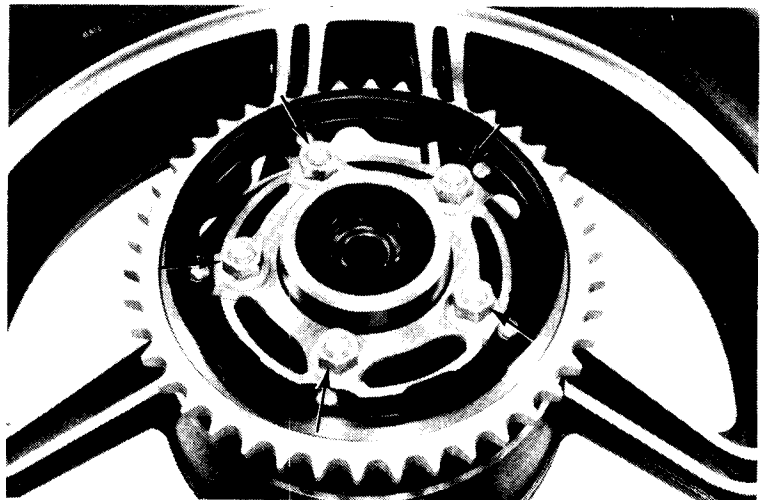



Remove the collar and oil seal from driven flange.

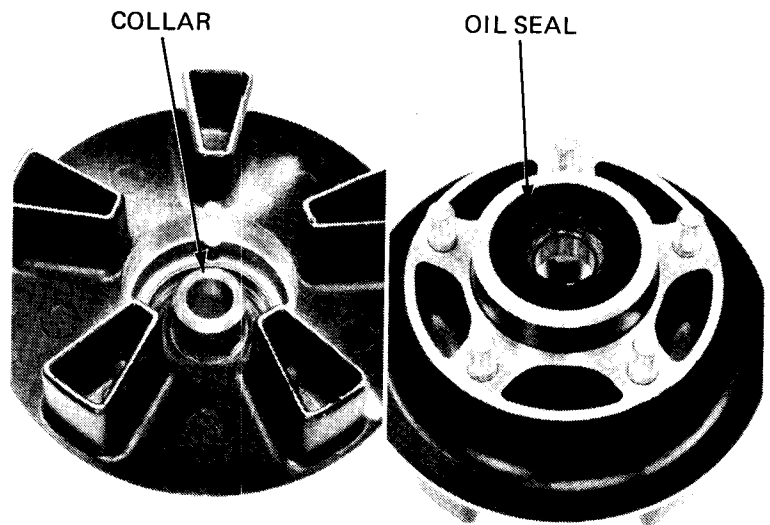

Remove the circlip and the left bearing.

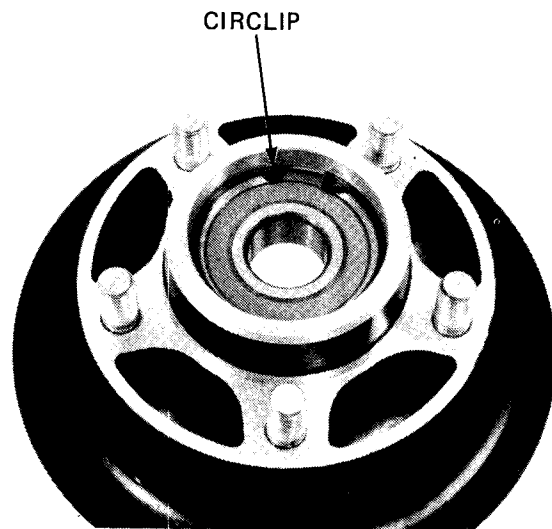

Remove the oil seal from wheel hub.  
Remove the bearings and distance collar.

See bearing inspection page 15-3 before removing.  
The bearing must be replaced with a new one if it is removed.

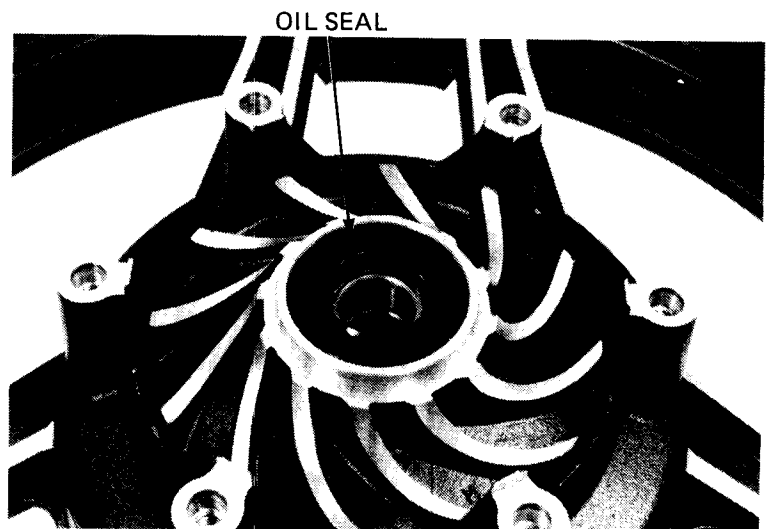



## REAR WHEEL/SUSPENSION

### INSPECTION

#### AXLE

Set the axle in V blocks and read the axle runout with a dial indicator.

The actual axle runout is 1/2 of the total indicator reading.

**SERVICE LIMIT: 0.2 mm (0.01 in)**

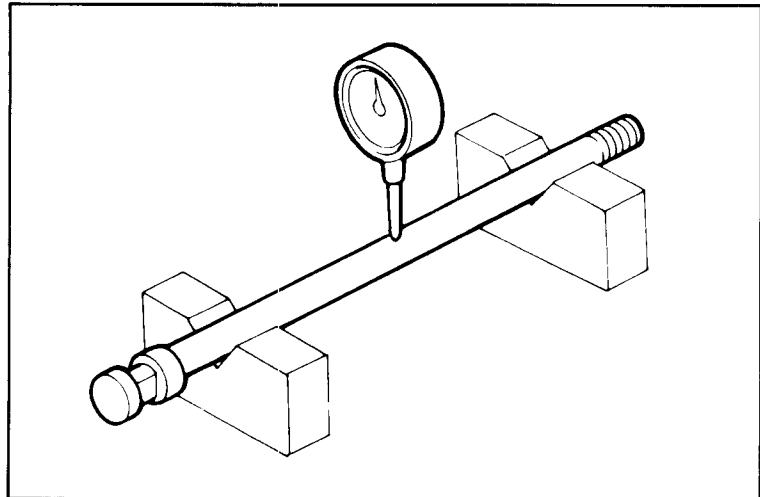

#### REAR WHEEL BEARING

Check the wheel bearing play by rotating the wheel by hand. Replace the bearings with new ones if they are noisy or have excessive play.

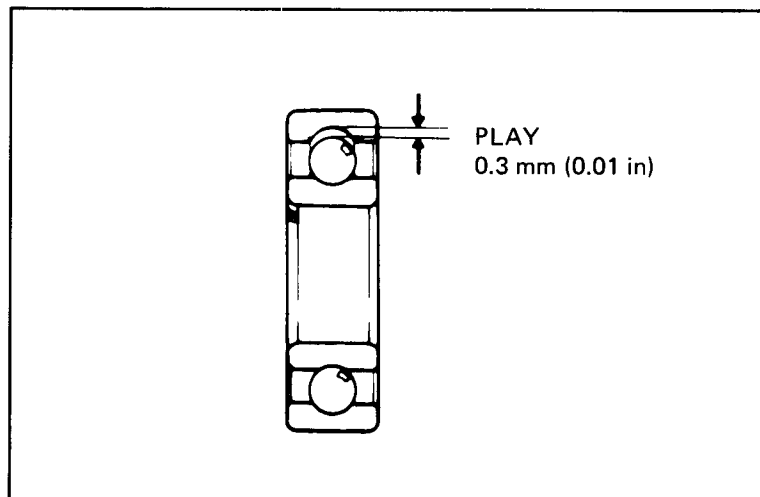

#### REAR WHEEL RIM RUNOUT

Check the rim for runout by placing the wheel in a truing stand. Spin the wheel slowly, and read the runout using a dial indicator.

**SERVICE LIMITS:**

**RADIAL RUNOUT: 2.0 mm (0.08 in)**

**AXIAL RUNOUT: 2.0 mm (0.08 in)**

**NOTE:**

The wheel cannot be serviced and must be replaced if the above limits are exceeded.

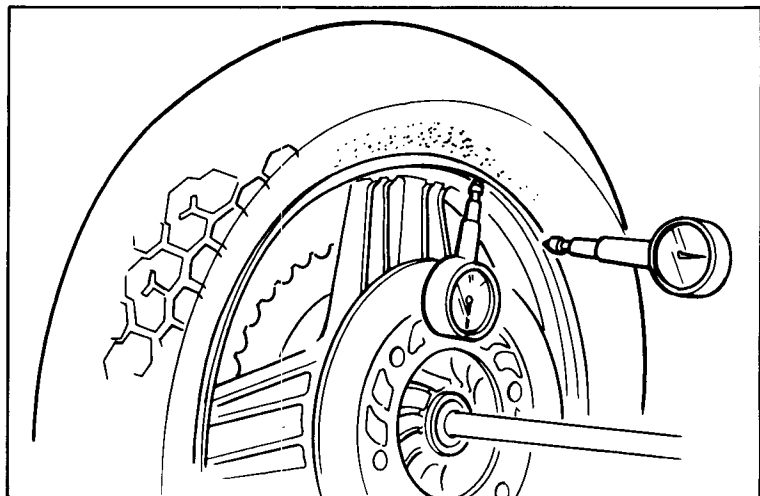



### FINAL DRIVEN SPROCKET

Check the condition of the final driven sprocket teeth. Replace the sprocket if worn or distorted.

**NOTE:**

If the final driven sprocket requires replacement, inspect the drive chain and drive sprocket.

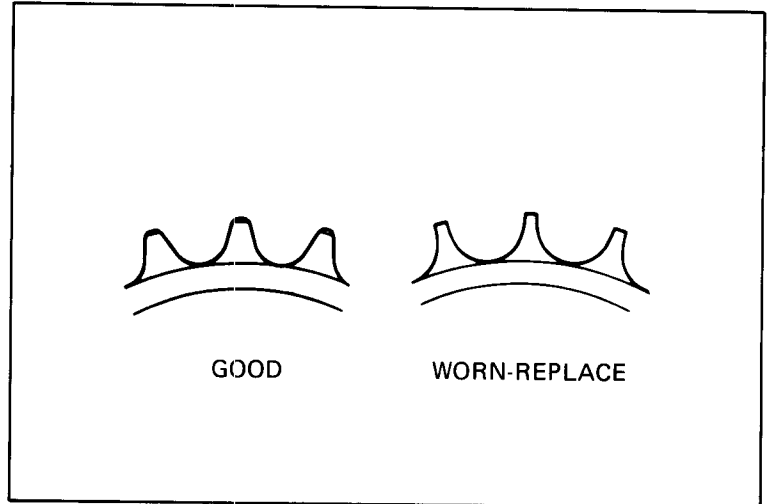

### DAMPER RUBBERS

Replace the damper rubbers if they are damaged or deteriorated.

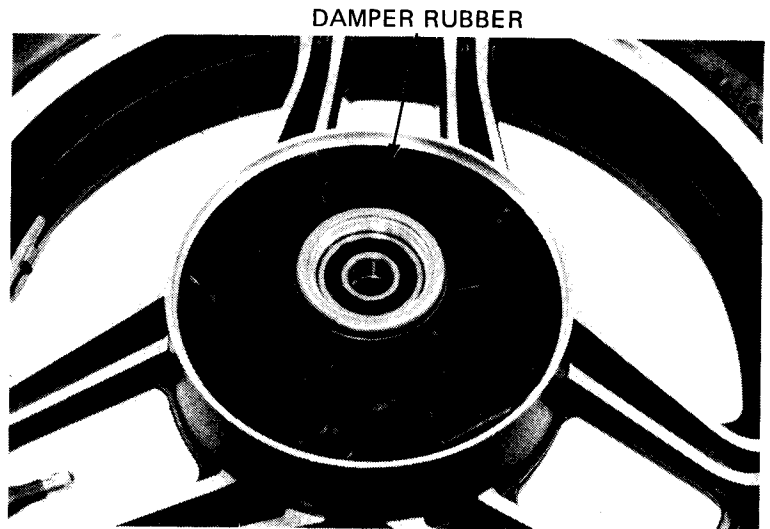



**REAR WHEEL/SUSPENSION**

**ASSEMBLY**

**NOTE:**

The rear wheel uses a tubeless tire. For tubeless tire repairs, refer to the Tubeless Tire Manual.

**WARNING**

*Do not get grease on the brake disc or stopping power will be reduced.*

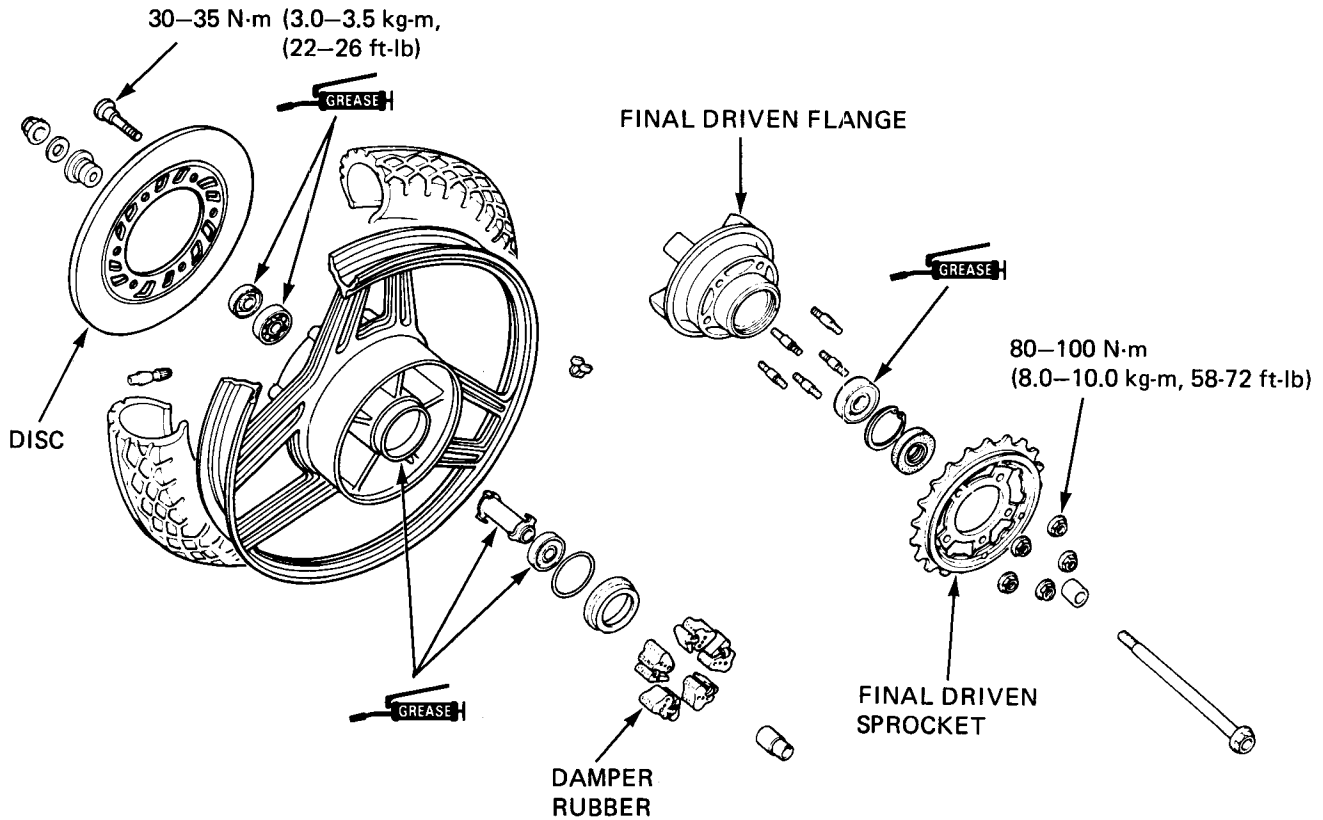

**DRIVEN FLANGE SIDE:**  
DRIVER 07749-0010000  
ATTACHMENT, 62 x 68 mm 07746-0010500  
PILOT, 25 mm 07746-0040600

Pack all bearing cavities with grease.  
Press the distance collar into place from the left side.  
Drive the right ball bearing in first, then the left ball bearing.

**CAUTION:**

*Drive the bearings in squarely with the sealed end facing out, making sure they are fully seated.*

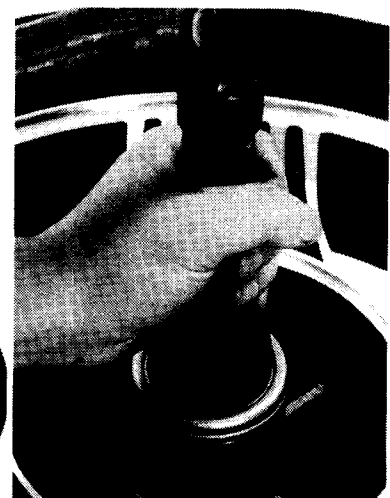
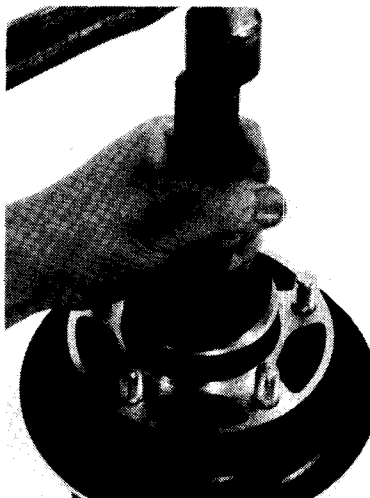

**WHEEL HUB SIDE:**  
ATTACHMENT, 52 x 55 mm 07746-0010400  
ATTACHMENT PILOT, 20mm 07746-0040500



After driving the bearing into the driven flange install the circlip.

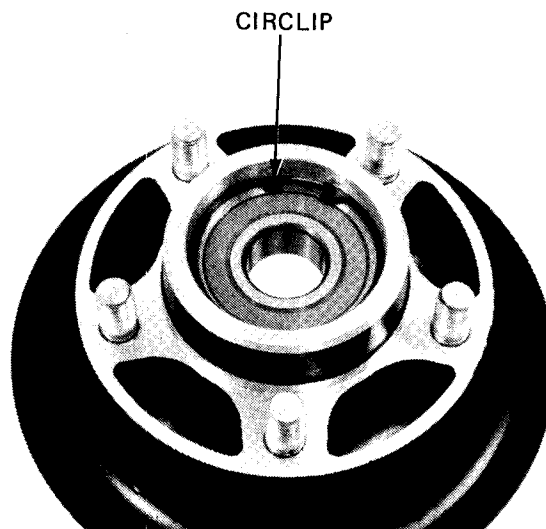

Install new oil seals into the driven flange and the wheel hub.

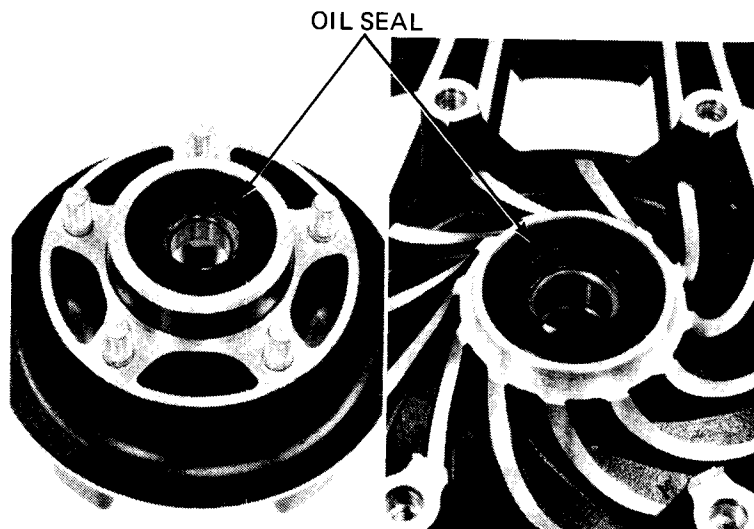

Install the collar into the final driven flange.  
Install the final driven flange onto the wheel hub.  
Install the final driven sprocket.

**TORQUE: 80–100 N·m**  
**(8.0–10.0 kg·m, 58–72 ft·lb)**

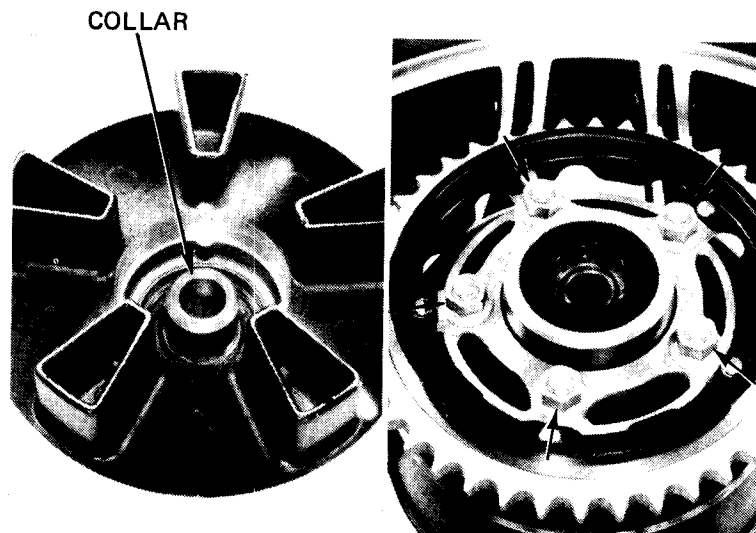



## REAR WHEEL/SUSPENSION

Install the rear brake disc.

**TORQUE: 30–35 N·m**  
(3.0–3.5 kg-m, 22–26 ft-lb)

Clean the brake disc with a high quality degreasing agent.

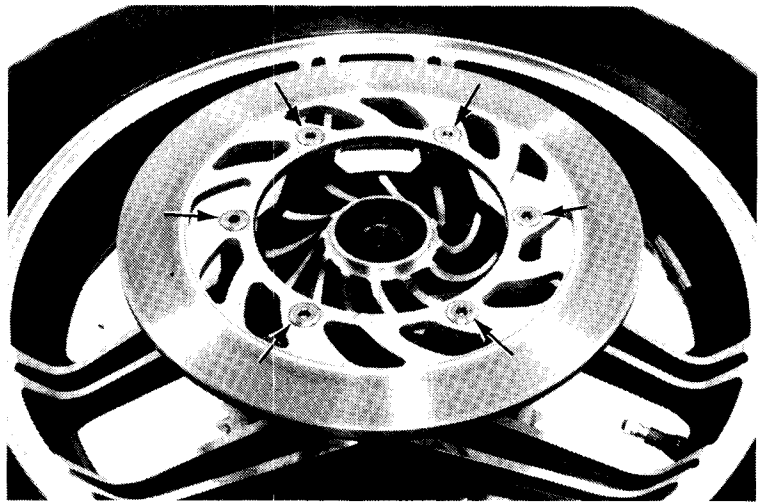

Place the collars into the wheel hub and driven flange oil seals.

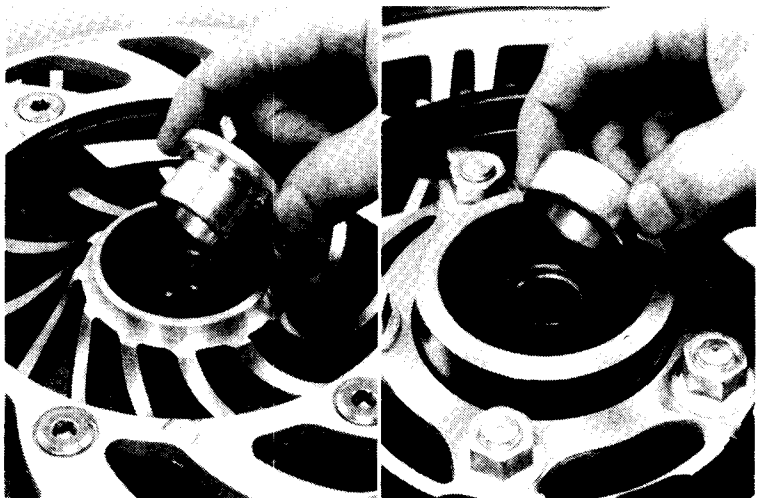

## INSTALLATION

Install the rear wheel in the reverse order of removal.

### NOTE:

- When installing the wheel, carefully fit the brake disc between the brake pads.
- After installing the wheel, apply the brake several times. Then check that the wheel rotates freely. Recheck wheel installation if the brake drags or if the wheel does not rotate freely.

**TORQUE: 80–100 N·m**  
(8.0–10.0 kg-m, 58–72 ft-lb)

Adjust the drive chain slack (page 3–15).





## SHOCK ABSORBER

### REMOVAL

Remove the side grip and shock absorber lower mounting bolt.  
Remove the shock absorber.

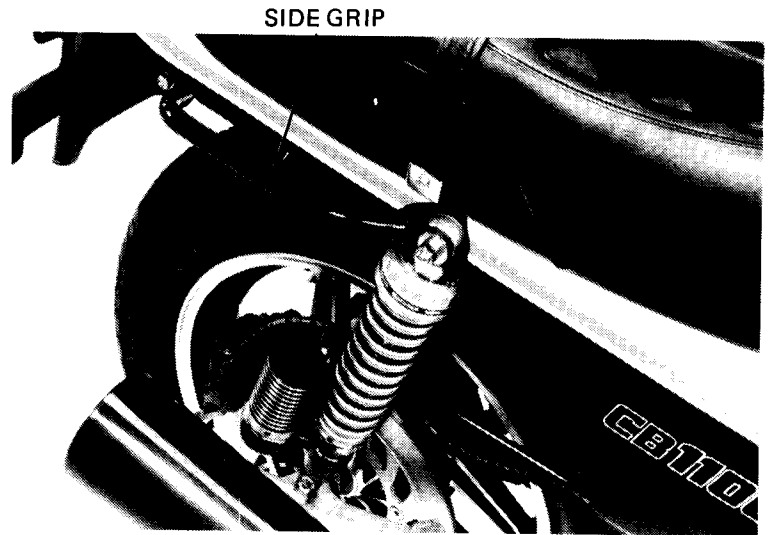

SIDE GRIP

### DISASSEMBLY

Compress the spring with the shock absorber compressor just enough to remove the rebound damping adjuster.  
Remove the compressor, spring seat, case, spring and adjuster.

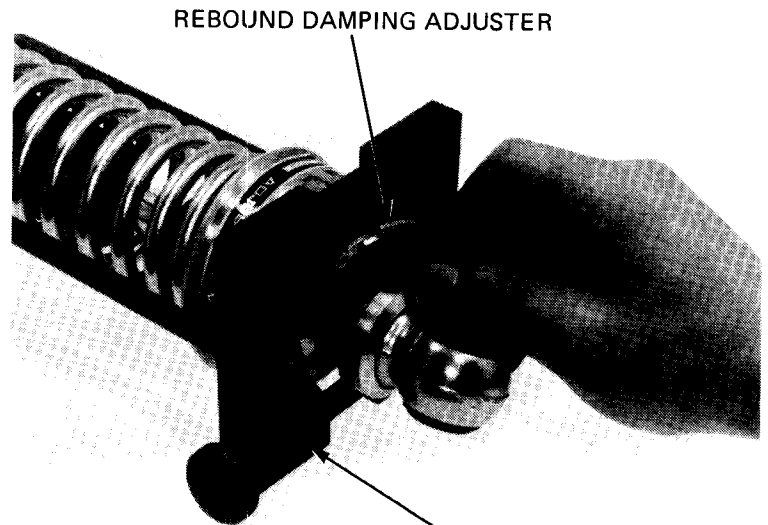

REBOUND DAMPING ADJUSTER

### NOTE:

Do not try to disassemble the shock absorber any further.

### WARNING

- Before discarding the shock absorber release the air pressure by removing the reservoir cap and depressing the valve core.
- Do not place the shock absorber near extreme heat or it will explode.

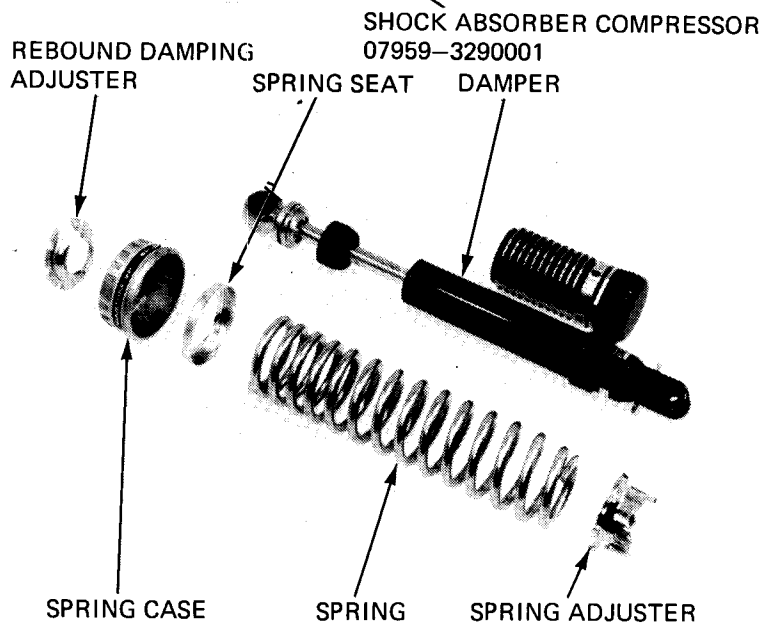

REBOUND DAMPING ADJUSTER

SHOCK ABSORBER COMPRESSOR  
07959-3290001

SPRING SEAT

DAMPER

SPRING CASE

SPRING

SPRING ADJUSTER



**REAR WHEEL/SUSPENSION**

**INSPECTION**

Check the shock absorber spring free length and replace the spring if shorter than the service limit.

**SERVICE LIMIT: 233.0 mm (9.17 in)**

Inspect the shock absorber damper for damage or oil leaks. Replace the damper if it is damaged or leaking.

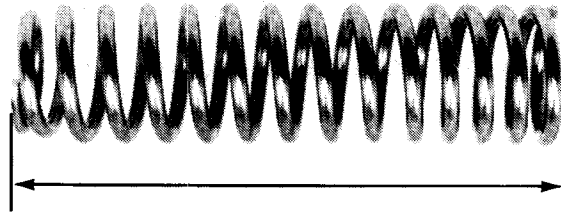

**ASSEMBLY**

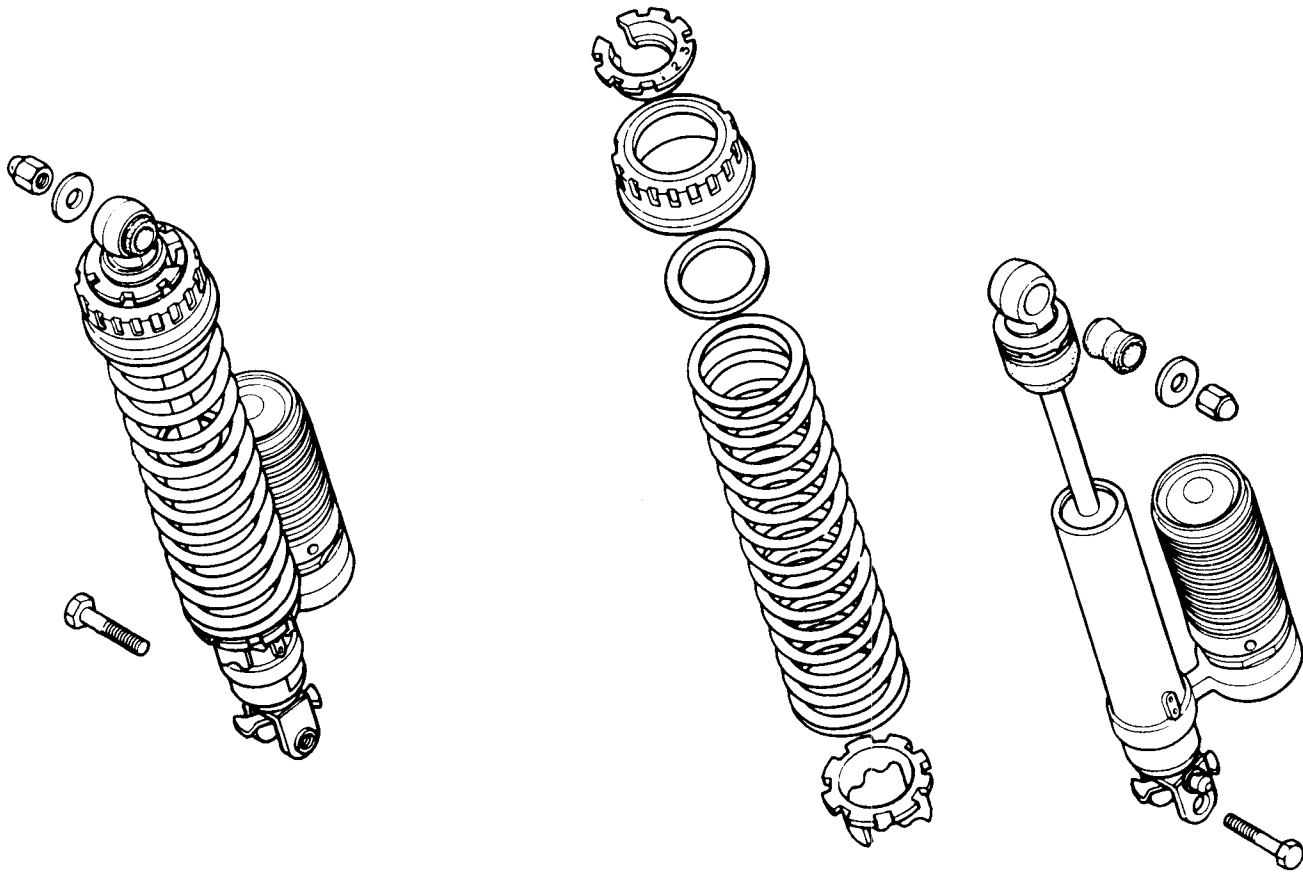



Install the spring adjuster over the damper.

Install the shock absorber spring over the spring adjuster and damper with the narrow coils toward the top.

Install the spring case and seat.

Install the rebound damping adjuster with the spring compressor, aligning the lug on the upper eye with the cutout in the adjuster.

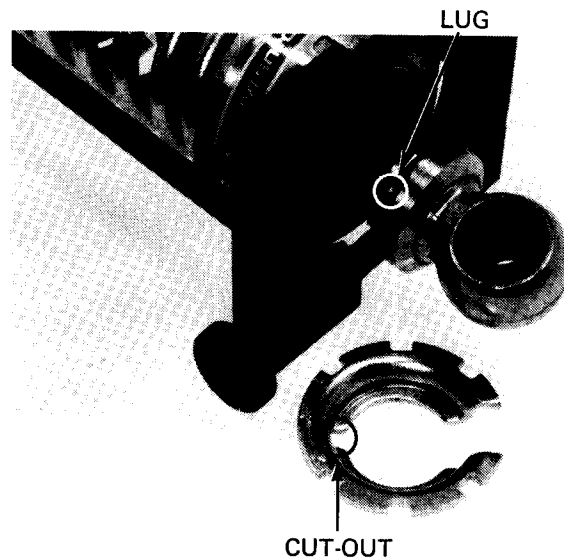

### INSTALLATION

Install the shock absorber and lower mounting bolt.

Install the side grip and upper mounting nut.

Tighten the mounting bolt and nut.

**TORQUE: 30–40 N·m**  
**(3.0–4.0 kg-m, 22-29 ft-lb)**

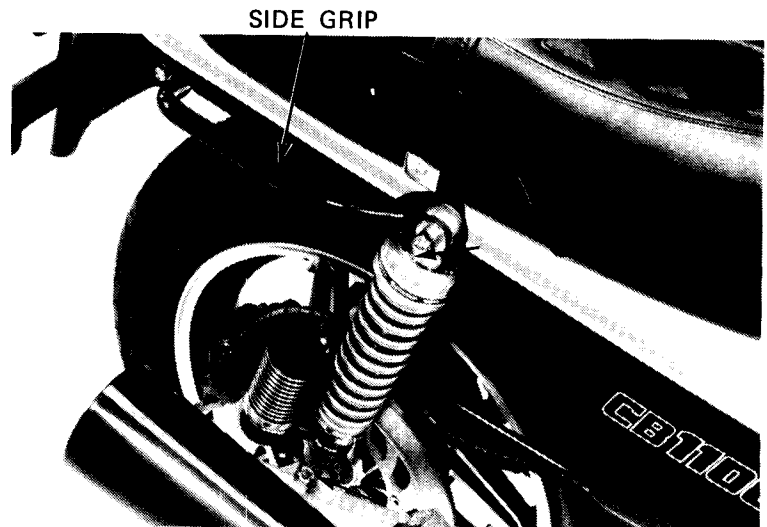



## REAR WHEEL/SUSPENSION

### SWING ARM

#### REMOVAL

Remove the rear wheel (page 15-2).

Remove the chain guard.

Disconnect the rear brake torque rod from the swingarm.

#### NOTE:

To prevent damage to the caliper or brake hose, support the caliper with a piece of wire to the frame. Do not allow the caliper to hang by the brake hose.

Remove the rear shock absorber lower mounting bolts.

Remove the swingarm pivot bolt and remove the swingarm.

#### DISASSEMBLY

Remove the dust covers and the collar.

Remove the bearings and thrust bushings with the two piece bearing remover. Insert the collet into the bearing. Then insert the expander/driver into the collet from the other end of the swingarm and drive out the bearing.

#### INSPECTION

Inspect the collar and bearings.

Replace them if they have score marks, scratches, excessive or abnormal wear.

REAR BRAKE TORQUE ROD

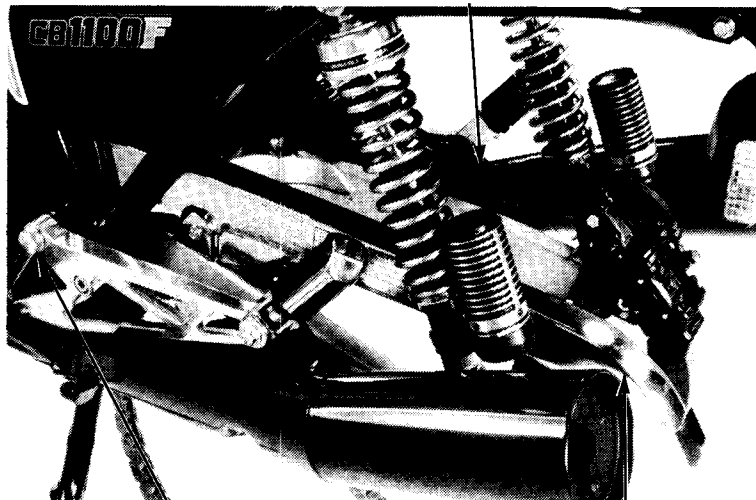

SWINGARM PIVOT BOLT

CHAIN GUARD

NEEDLE BEARING REMOVER  
M9310-277-91774  
H/C 091774 (USA only)

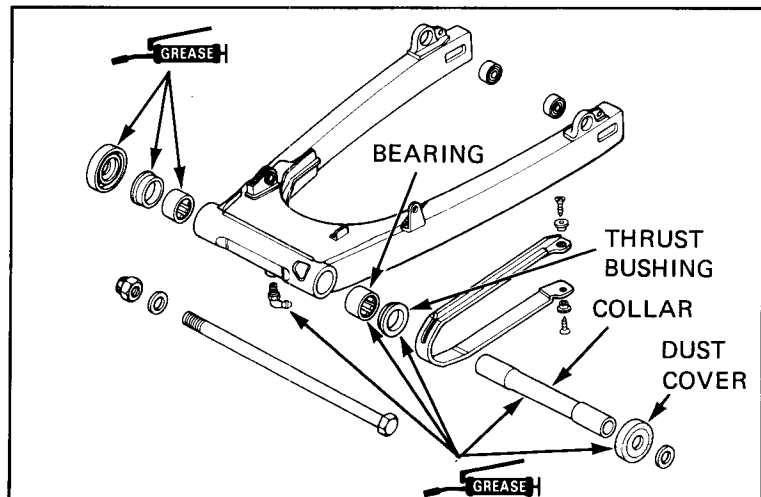
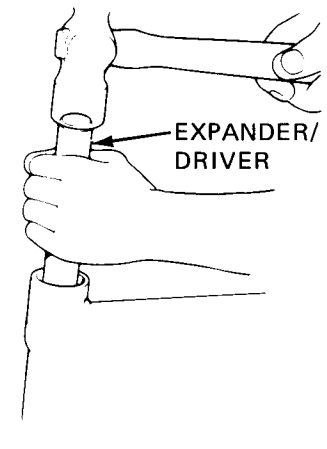
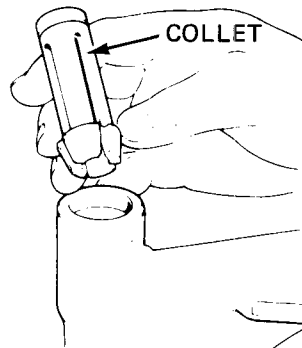



**ASSEMBLY**

Clean the bearings thoroughly, then lubricate them with grease.

Carefully drive the bearings into the swingarm with the special tool. Drive the thrust bushings into the swingarm with the same special tool.

**NOTE:**

Install the bearings with the markings facing out.

Lubricate with grease after installation.  
Install the collar.

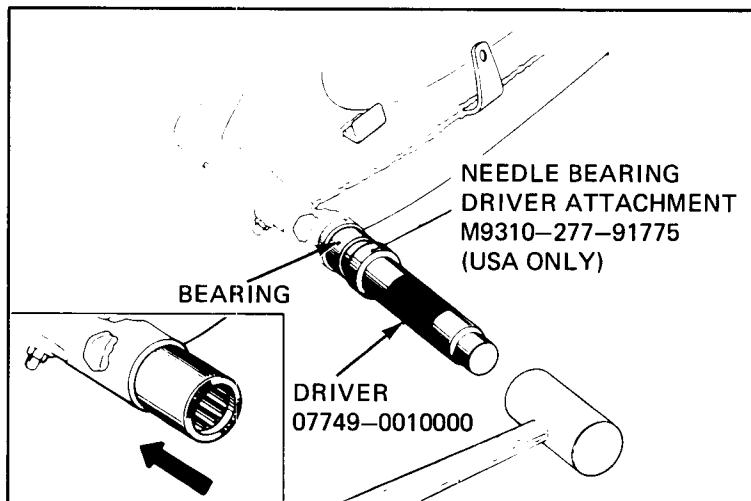

**INSTALLATION**

Place the drive chain over the swingarm.

Tighten the swingarm pivot bolt.

**TORQUE: 60–70 N·m**  
**(6.0–7.0 kg·m, 43–51 ft·lb)**

Install and tighten the rear shock absorber lower mounting bolts.

**TORQUE: 30–40 N·m**  
**(3.0–4.0 kg·m, 22–29 ft·lb)**

Connect the rear brake torque rod to the swingarm and tighten the nut.

**TORQUE: 18–25 N·m**  
**(1.8–2.5 kg·m, 13–18 ft·lb)**

Secure the torque rod nut with a new cotter pin.  
Install the chain guard.

Install the rear wheel (page 15-8).

