



SERVICE INFORMATION	11-1
CRANKCASE DISASSEMBLY	11-2
CRANKCASE ASSEMBLY	11-3

## SERVICE INFORMATION

### GENERAL

- To repair the crankshaft, connecting rod, primary shaft and the transmission including the shift fork and drum, it is necessary to separate the crankcase halves.
- The following parts must be removed before disassembling the crankcase.
  - Oil pan See section 2
  - Oil pump See section 2
  - Clutch and starter clutch See section 6
  - Gear shift linkage See section 7
  - Alternator See section 8
  - Cylinder head See section 9
  - Cylinder/piston See section 10
  - Starter motor See section 19

### TORQUE VALUES

8 mm bolt (Crankshaft)	21-25 N·m (2.1-2.5 kg-m, 15-18 ft-lb)
8 mm bolt (Crankcase)	21-25 N·m (2.1-2.5 kg-m, 15-18 ft-lb)
6 mm bolt	10-14 N·m (1.0-1.4 kg-m, 7-10 ft-lb)
10 mm bolt	45-50 N·m (4.5-5.0 kg-m, 33-36 ft-lb)



## CRANKCASE

### CRANKCASE DISASSEMBLY

Remove the components listed under General on page 11-1.

Remove the upper crankcase bolts.

Turn the engine upside-down and remove the lower crankcase bolts.

#### NOTE:

Remove the bolts in two or more steps and in a crisscross pattern to prevent warpage.

Separate the crankcase halves.

#### CAUTION:

*Do not pry between the upper and lower cases.*

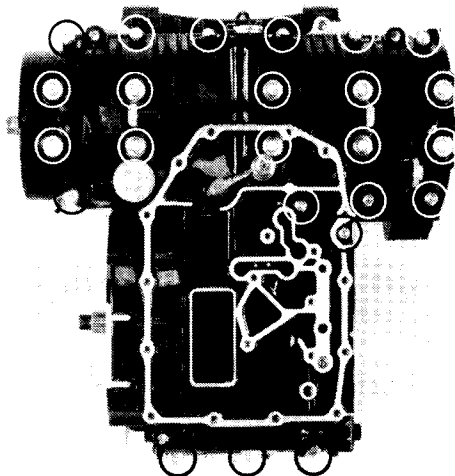
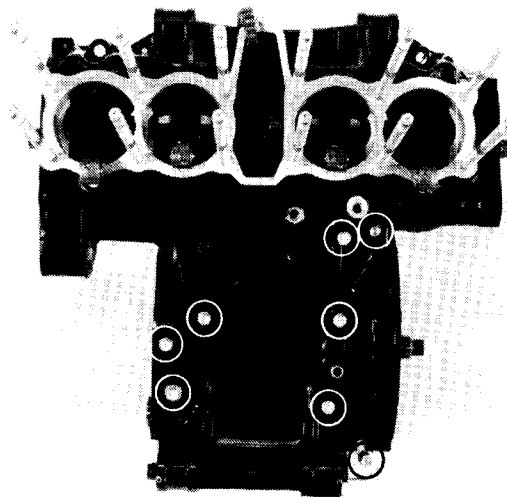



### CRANKCASE ASSEMBLY

Slide the transmission C4 gear into the C1 gear.  
Make sure that the other gears are not engaged.

Apply molybdenum disulfide grease to the grooves of the M3, C4 and C5 gears.

Apply molybdenum disulfide grease to the crankshaft main bearings.

Clean the crankcase mating surfaces.  
Apply liquid sealant to the mating surfaces of the crankcase halves.

**CAUTION:**

*Do not apply sealant to the area near the main bearings.*

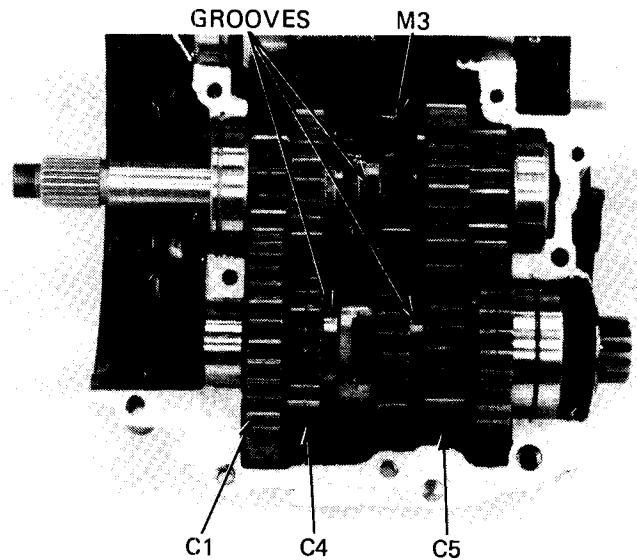
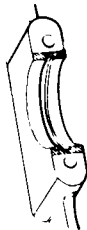

LOWER CRANKCASE

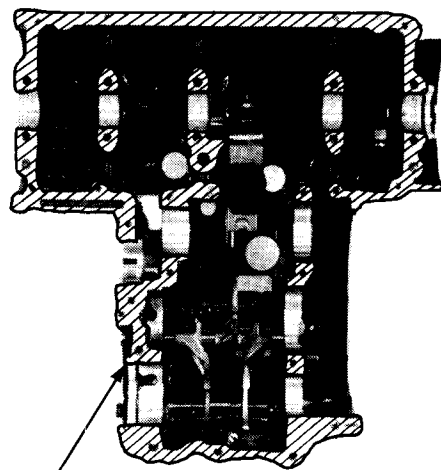

SEALANT

UPPER CRANKCASE

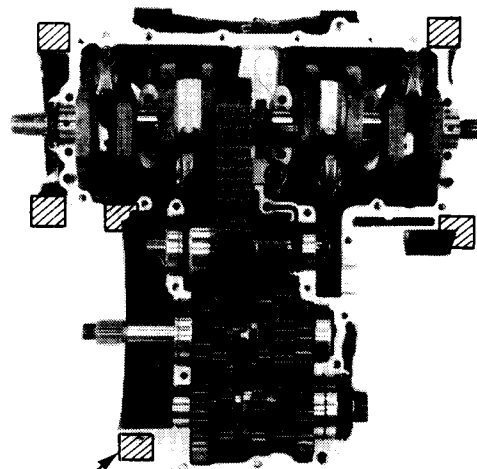

SEALANT

## CRANKCASE



**HONDA**  
**CB1100F**

Assemble the crankcase halves, aligning the shift fork claws with the gears.  
Tighten the bolts to the specified torque values in the sequence shown.

### TORQUE VALUES:

8 mm bolt (Crankshaft):

21–25 N·m (2.1–2.5 kg·m, 15–18 ft·lb)

8 mm bolt (Crankcase):

21–25 N·m (2.1–2.5 kg·m, 15–18 ft·lb)

6 mm bolt

10–14 N·m (1.0–1.4 kg·m, 7–10 ft·lb)

10 mm bolt

45–50 N·m (4.5–5.0 kg·m, 33–36 ft·lb)

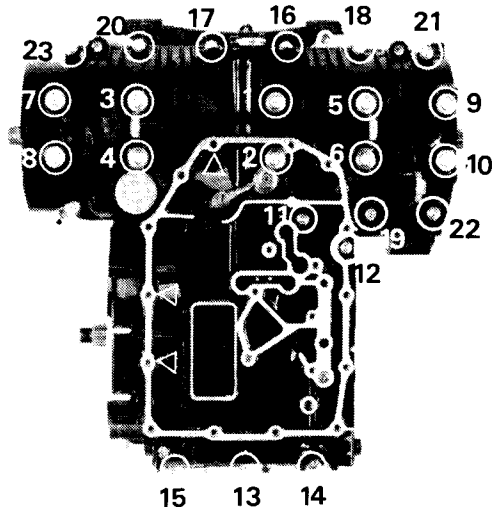

### NOTE:

- Make sure that the plain washers are under the bolt head of the ten crankshaft bearing bolts.
- Apply engine oil to the threads and head of the ten crankshaft holding bolts.
- Use the sealing washers under the bolt heads for holes with the mark "Δ" on the crankcase.

Tighten the upper crankcase bolts to the specified torque, proceeding front to rear.

### NOTE:

If the oil galley cap is removed, apply molybdenum disulfide grease to the threads before installing.

