



9. CYLINDER HEAD/VALVE

SERVICE INFORMATION	9- 1	VALVE GUIDE REPLACEMENT	9-15
TROUBLESHOOTING	9- 2	VALVE SEAT INSPECTION/ REFACING	9-16
CAMSHAFT REMOVAL	9- 3	CYLINDER HEAD ASSEMBLY	9-17
CYLINDER HEAD REMOVAL	9- 9	CYLINDER HEAD INSTALLATION	9-19
CYLINDER HEAD DISASSEMBLY	9-11	CAMSHAFT INSTALLATION	9-20

SERVICE INFORMATION

GENERAL

- The engine must be removed from the frame to remove the cylinder head.
- Camshaft lubricating oil is fed through an oil line. Be sure the hole in the oil line is not clogged.
- During assembly, apply molybdenum disulfide to the camshaft bearings to provide initial lubrication. Pour clean engine oil into the oil pockets in the cylinder head to lubricate the camshafts.
- Marks A thru L on the camshaft holders indicate installation positions. A to E are for the EX. side and F to L are for the IN. side from left to right respectively. When installing, be sure the mark "▲" faces forward.

SPECIFICATIONS

			STANDARD	SERVICE LIMIT
Compression pressure			12 ± 2 kg/cm ² (171 ± 28 psi)	—
Camshaft	Cam height	IN.	38.0–38.160 mm (1.496–1.502 in)	37.9 mm (1.49 in)
		EX.	39.0–39.160 mm (1.535–1.542 in)	38.9 mm (1.53 in)
	Oil clearance	A and F	0.040–0.082 mm (0.0016–0.0032 in)	0.13 mm (0.005 in)
		Tachometer gear holder and G	0.062–0.109 mm (0.0024–0.0043 in)	0.16 mm (0.006 in)
		B and H	0.085–0.139 mm (0.0033–0.0055 in)	0.19 mm (0.007 in)
		C and J	0.085–0.139 mm (0.0033–0.0055 in)	0.19 mm (0.007 in)
		D and K	0.062–0.109 mm (0.0024–0.0043 in)	0.16 mm (0.006 in)
		E and L	0.040–0.082 mm (0.0016–0.0032 in)	0.13 mm (0.005 in)
	Run out		—	0.05 mm (0.002 in)
Side clearance		0.05 –0.25 mm (0.002 –0.10 in)	0.4 mm (0.02 in)	
Valve lifter	Valve lifter O.D.		27.972–27.993 mm (1.1013–1.1021 in)	27.96 mm (1.1008 in)
	Valve lifter bore I.D.		28.000–28.016 mm (1.1023–1.1029 in)	28.04 mm (1.1039 in)
	Lifter to cylinder head clearance		—	0.07 mm (0.003 in)
Valve spring	Free length	IN. Outer	44.1 mm (1.736 in)	42.7 mm (1.681 in)
		IN. Inner	39.4 mm (1.551 in)	38.5 mm (1.515 in)
		EX. Outer	44.1 mm (1.736 in)	42.7 mm (1.681 in)
		EX. Inner	39.4 mm (1.551 in)	38.5 mm (1.515 in)
	Preload/length	IN. Outer	14.6–16.6 kg/37.5 mm (32.44–36.89 lbs/1.48 in)	14.0 kg/37.5 mm (31.11 lbs/1.48 in)
		IN. Inner	5.9–7.3 kg/34.5 mm (13.11–16.22 lbs/1.36 in)	5.5 kg/34.5 mm (12.22 lbs/1.36 in)
		EX. Outer	14.6–16.6 kg/37.5 mm (32.44–36.89 lbs/1.48 in)	14.0 kg/37.5 mm (31.11 lbs/1.48 in)
		EX. Inner	5.9–7.3 kg/34.5 mm (13.11–16.22 lbs/1.36 in)	5.5 kg/37.5 mm (12.22 lbs/2.36 in)

**CYLINDER HEAD/VALVE**

			STANDARD	SERVICE LIMIT
Valve guide and valve	Valve stem O.D.	IN.	5.475–5.490 mm (0.2156–0.2161 in)	5.47 mm (0.215 in)
		EX.	5.455–5.470 mm (0.2148–0.2154 in)	5.44 mm (0.214 in)
	Valve guide I.D.	IN.	5.500–5.515 mm (0.2165–0.2171 in)	5.54 mm (0.2181 in)
		EX.	5.500–5.515 mm (0.2165–0.2171 in)	5.54 mm (0.2181 in)
	Stem-to-guide clearance	IN.	—	0.07 mm (0.0027 in)
		EX.	—	0.10 mm (0.0035 in)
Valve seat width			0.85–1.10 mm (0.0334–0.044 in)	1.5 mm (0.059 in)
Cylinder head	Warpage		—	0.10 mm (0.0039 in)
Cam chain	Length		175.70–175.92 mm (6.917–6.926 in)	177.3 mm (6.98 in)

TORQUE VALUES

Cam chain tensioner bolts	10–14 N·m (1.0–1.4 kg-m, 7–10 ft-lb)
Cam chain tensioner lock nut	11–15 N·m (1.1–1.5 kg-m, 8–11 ft-lb)
Cylinder head cover bolts	8–12 N·m (0.8–1.2 kg-m, 6–9 ft-lb)
Camshaft holder bolts	12–16 N·m (1.2–1.6 kg-m, 9–12 ft-lb)
Cylinder head nuts	36–40 N·m (3.6–4.0 kg-m, 26–29 ft-lb)
Cam sprocket bolts	22–26 N·m (2.2–2.6 kg-m, 16–19 ft-lb)
Spark plugs	12–19 N·m (1.2–1.9 kg-m, 9–14 ft-lb)
Oil pipe	21–25 N·m (2.1–2.5 kg-m, 15–18 ft-lb)

TOOLS**Special**

Valve guide reamer	07984–2000000
Valve lifter bore protector	07999–4220000

Common

Valve guide remover, 5.5 mm	07742–0010100 or 07942–3290100
Valve guide driver	07742–0020200 or 07942–3290200
Valve spring compressor	07757–0010000

TROUBLESHOOTING

Engine top-end problems are usually performance-related and can be diagnosed by a compression test, or are engine noises which can be traced to the top-end with a sounding rod or stethoscope.

Low compression or Uneven compression

- Valves
 - Incorrect valve adjustment
 - Burned or bent valves
 - Incorrect valve timing
 - Broken valve springs
- Cylinder head
 - Leaking or damaged head gasket
 - Warped or cracked cylinder head
- Cylinder and piston (Refer to Section 10)

Compression too High

- Excessive carbon build-up on piston head or combustion chamber

Excessive Noise

- Incorrect valve adjustment
- Sticking valve or broken valve spring
- Damaged or worn camshaft
- Loose or worn cam chain
- Worn or damaged cam chain tensioner
- Worn cam sprocket teeth



CAMSHAFT REMOVAL

Place the motorcycle on its center stand.
Remove the seat and the fuel lines and fuel tank.

Disconnect the tachometer cable, and remove the spark plug caps.

Remove the cylinder head cover bolts and the cylinder head cover.

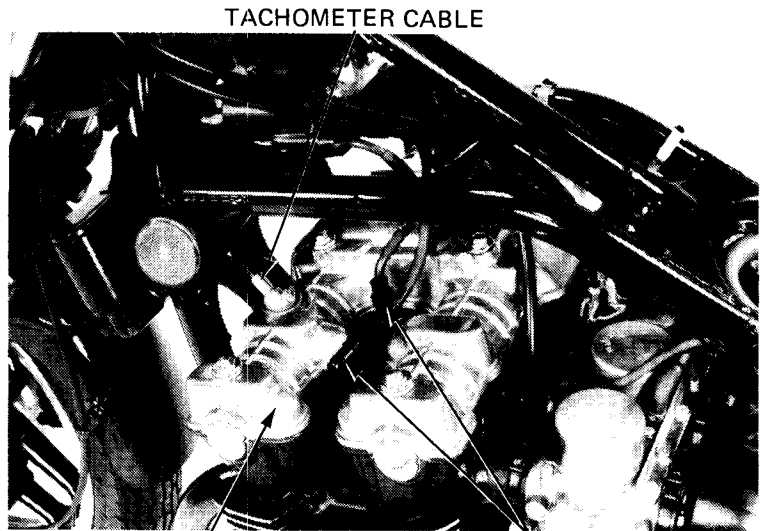

TACHOMETER CABLE
CYLINDER HEAD COVER SPARK PLUG CAPS

Remove the oil line and cam chain guide.

Remove the B, C, H and J camshaft holders.

Remove the oil pool caps and rear cam chain guide attaching plate.

Remove the dowel pins.

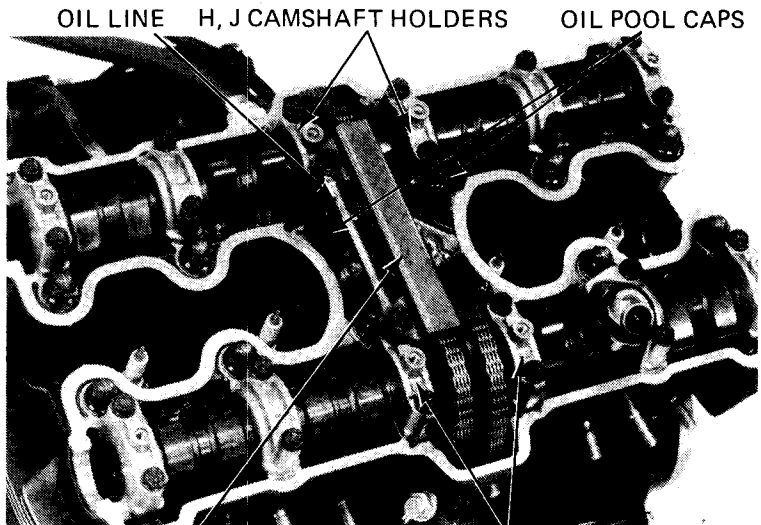

OIL LINE H, J CAMSHAFT HOLDERS OIL POOL CAPS

CHAM CHAIN GUIDE B, C CAMSHAFT HOLDERS

Loosen the front cam chain tensioner lock nut and bolt.

Press the cam chain tensioner down to reduce chain tension and tighten the lock bolt and nut.

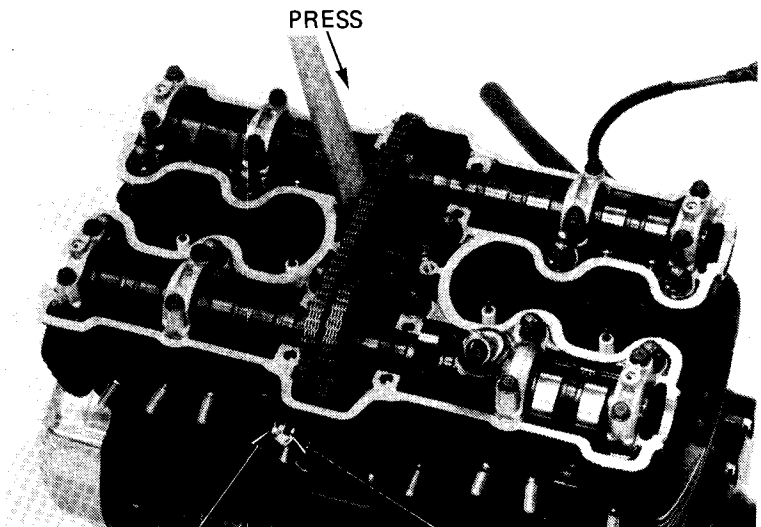

PRESS
FRONT CAM CHAIN TENSIONER FRONT LOCK NUT
LOCK BOLT



CYLINDER HEAD/VALVE

Loosen the rear chain tensioner lock nuts.

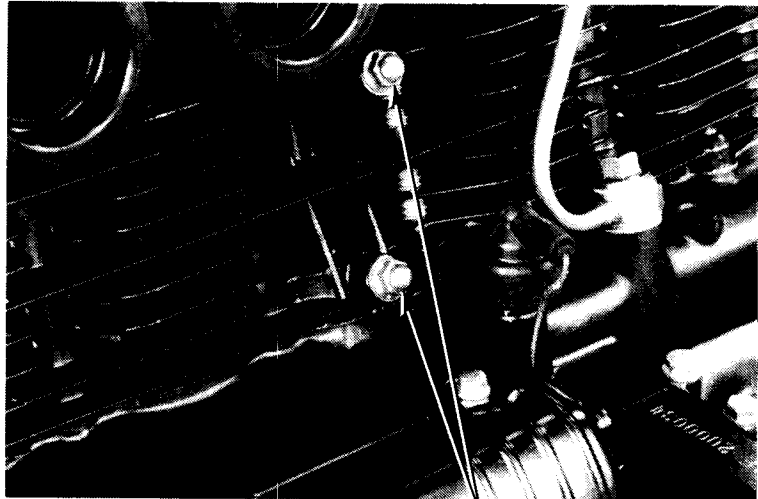

REAR LOCK NUTS

REAR CAM CHAIN TENSIONER

Push the rear cam chain tensioner rearward to reduce chain tension and tighten the lock nuts.

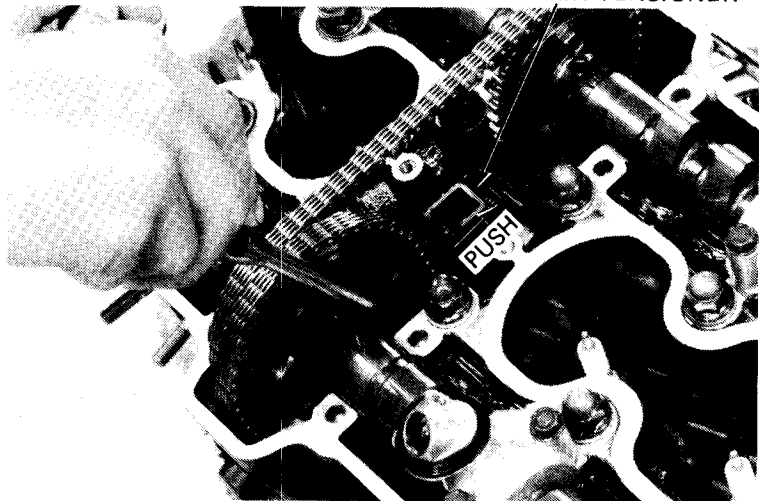

1.4 "T" MARK

Remove the pulse generator cover.

Turn the crankshaft counterclockwise until the "1.4T" mark aligns with the index mark.

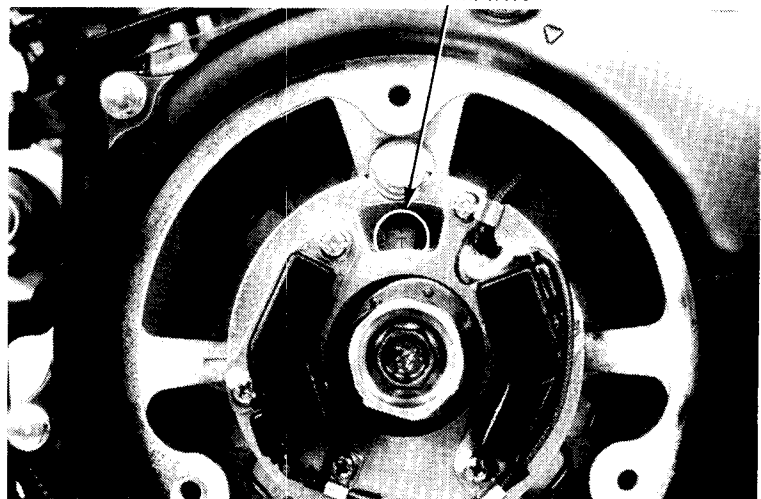



Make sure the No. 1 or 4 cylinder intake and exhaust cam lobes face the spark plug.

Remove the G, K, F and L camshaft holders. Remove the dowel pins.

NO. 4 CAM LOBES

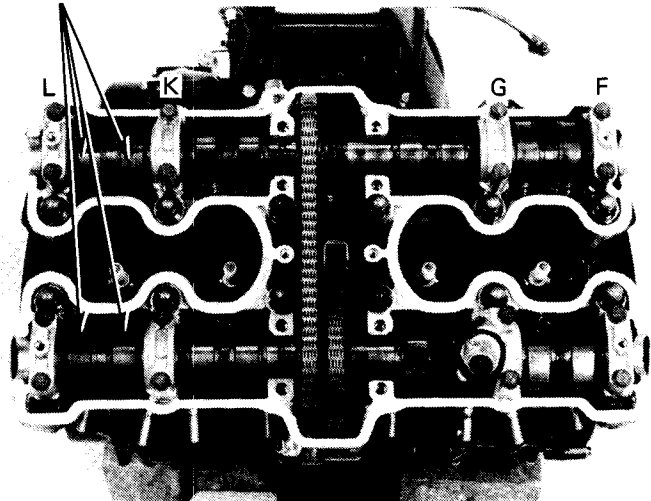

Remove the intake camshaft.

INTAKE CAMSHAFT

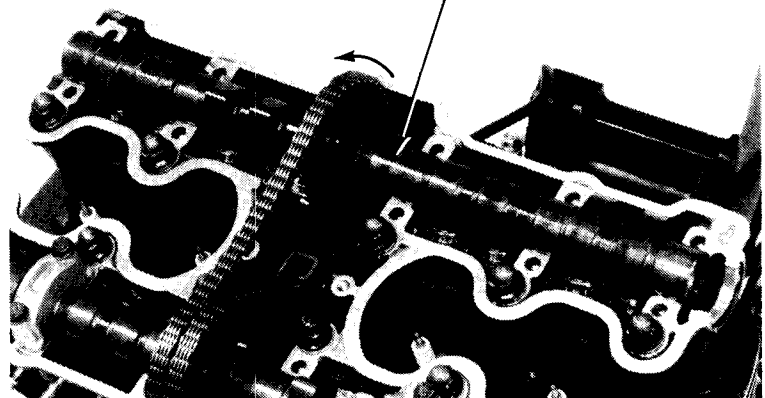

Loosen the exhaust cam sprocket bolt.

Turn the crankshaft counterclockwise until cam lift is minimal and the other cam sprocket bolt can be removed.

Remove the D and tachometer gear camshaft holders.

Remove the A and E holders. Remove the dowel pins.

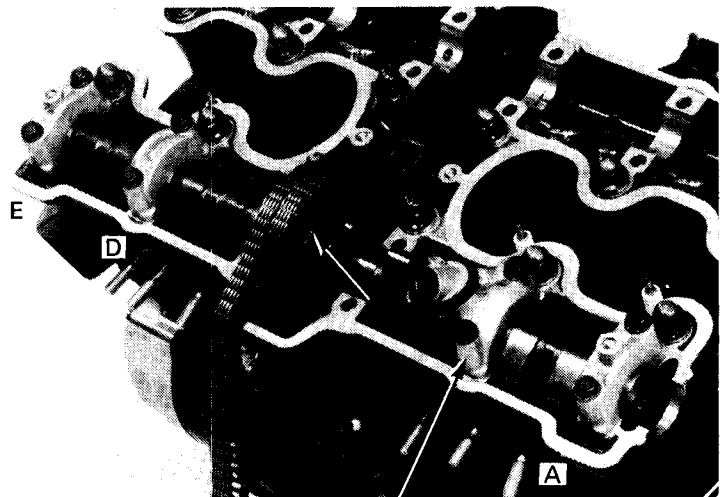

TACHOMETER GEAR
CAMSHAFT HOLDER



Remove the exhaust camshaft.

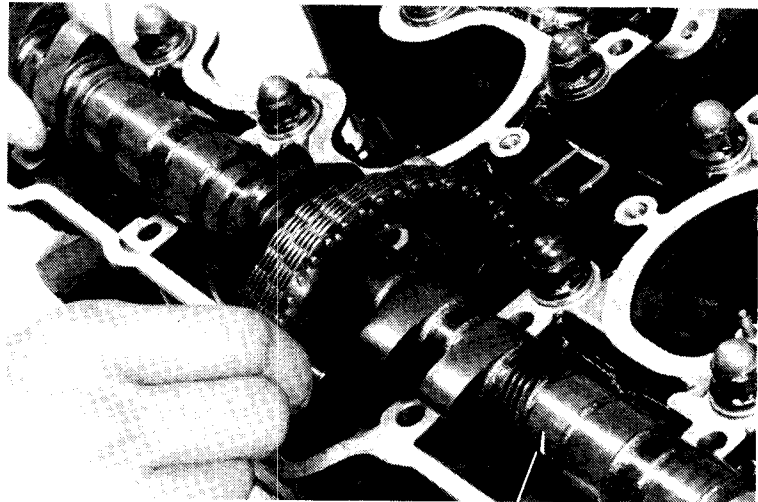

EXHAUST CAMSHAFT

NOTE:

Suspend the cam chain with a piece of wire to keep it from falling into the engine.

Remove the cam sprocket and intake cam drive chain.

NOTE:

After removing the camshaft, the valve clearance adjusting shims and valve lifters can be removed.

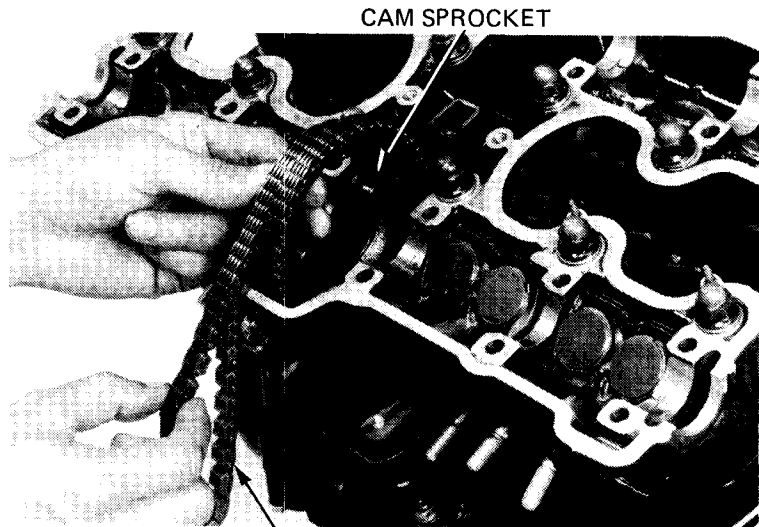

CAM SPROCKET

INTAKE CAM DRIVE CHAIN

CAM BEARING SURFACE INSPECTION

Inspect the cam bearing surfaces for scoring, scratches, or evidence of insufficient lubrication. Inspect the bearing surfaces of the camshaft holders.

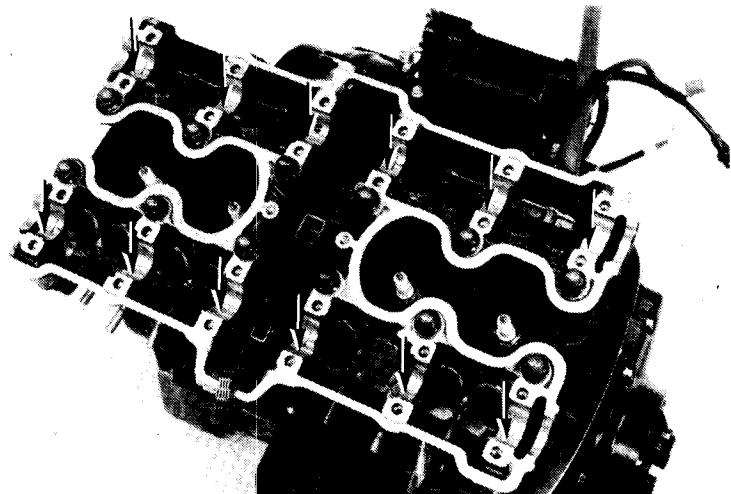



CAMSHAFT RUNOUT

Check camshaft runout with a dial indicator.
Support both ends of the camshaft with V-blocks.

SERVICE LIMIT: 0.05 mm (0.002 in)

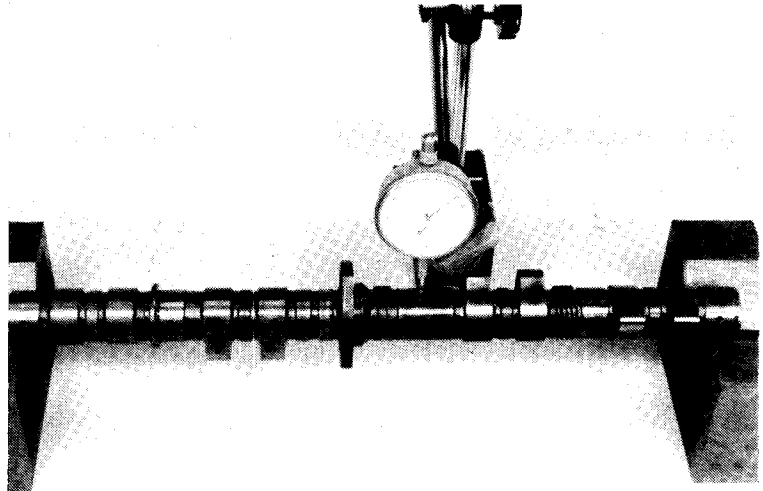

CAM LOBE HEIGHT

Using a micrometer, measure each cam lobe.
Check for wear or damage.

SERVICE LIMITS: IN: 37.9 mm (1.49 in)
EX: 38.9 mm (1.53 in)

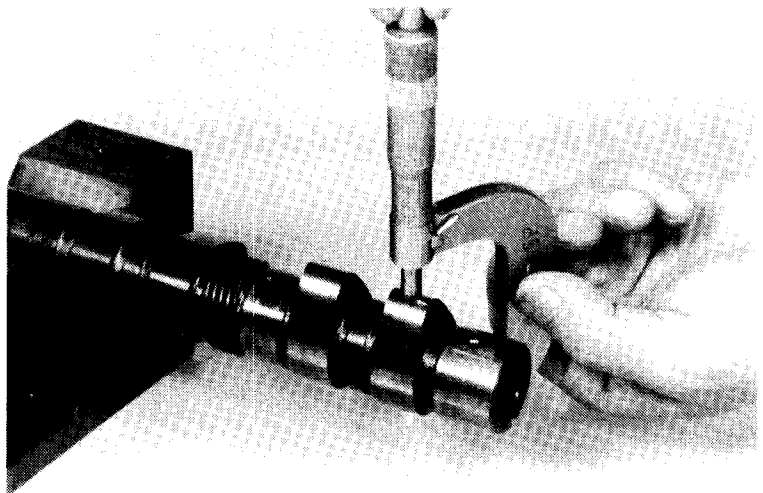

CAM CHAIN LENGTH

Place the cam chain over the intake camshaft sprockets. Secure one sprocket and apply 13 kg (29 lb) of tension with a spring scale. Measure the distance between the crankshaft index marks as shown.

SERVICE LIMIT: 177.3 mm (6.98 in)

CAM CHAIN GUIDE

Inspect the upper cam chain guide for damage or excessive wear.

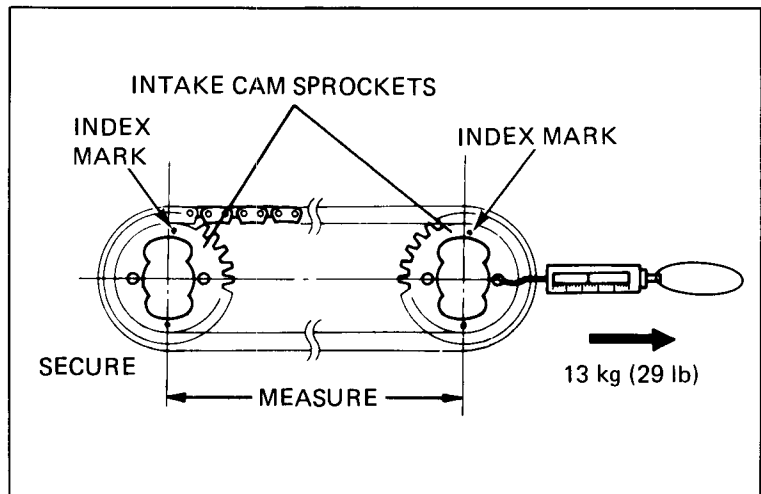



CYLINDER HEAD/VALVE

CAMSHAFT OIL CLEARANCE

Remove the adjusting shims and the valve lifters.

NOTE:

Mark each part to ensure correct reassembly.

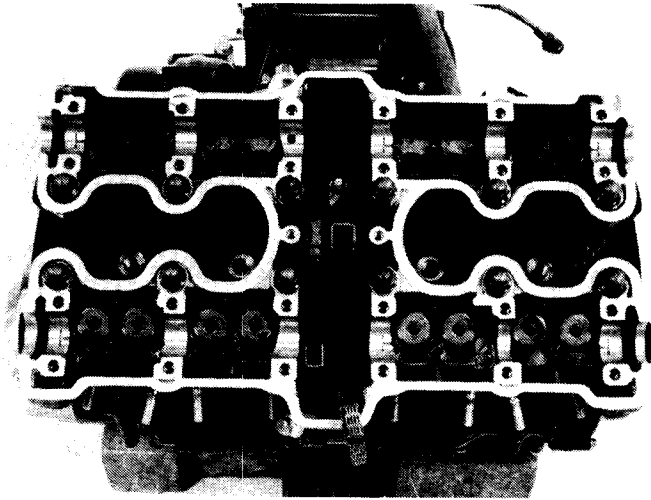

Lay a strip of plastigauge lengthwise on top of each camshaft journal.

NOTE:

Wipe any oil from the journals before using plastigauge.

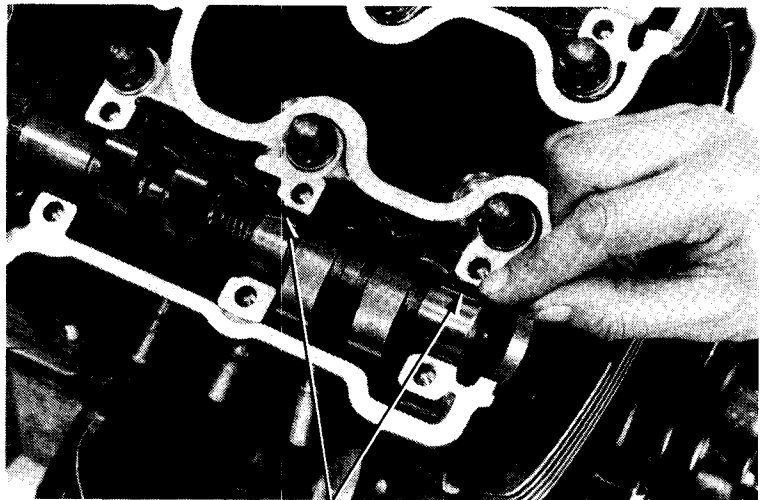

PLASTIGAUGE

IDENTIFICATION
LETTER

Check the camshaft holder identification letter before installing.

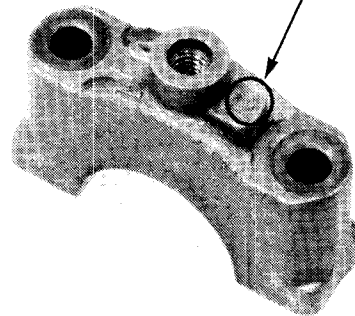



Install the camshaft holders in their correct positions and tighten in a crisscross pattern (see General, page 9-1).

NOTE:

Do not rotate the camshaft when using plastigauge.

TORQUE: 12–16 N·m (1.2–1.6 kg-m, 9–12 ft-lb)

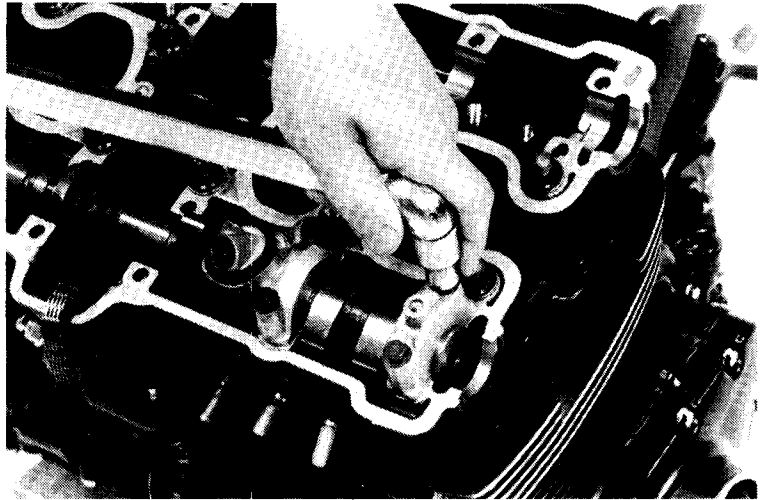

Remove the camshaft holders and measure the width of each plastigauge. The widest thickness determines the oil clearance.

SERVICE LIMITS:

A, E, F and L: 0.13 mm (0.005 in)
Gear holder, D, G and K: 0.16 mm (0.006 in)
B, C, H and J: 0.19 mm (0.007 in)

When the service limits are exceeded, replace the camshaft and recheck the oil clearance.

Replace the cylinder head and camshaft holders if the clearance still exceeds service limits.

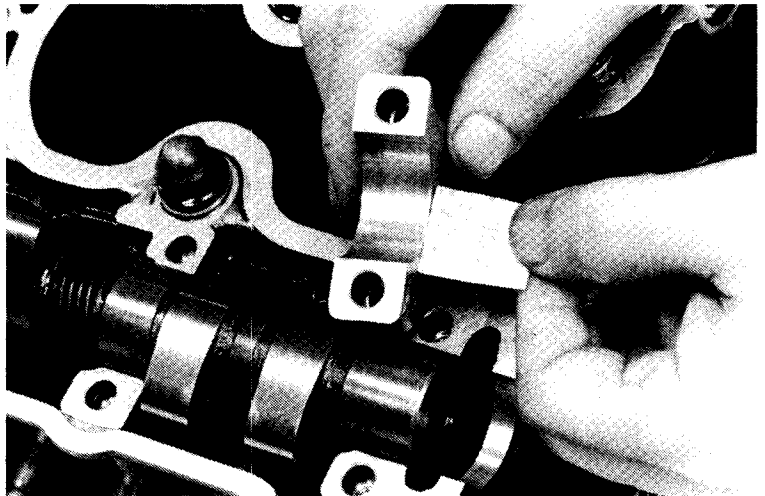

CYLINDER HEAD REMOVAL

Remove the two rear cam chain tensioner lock nuts.

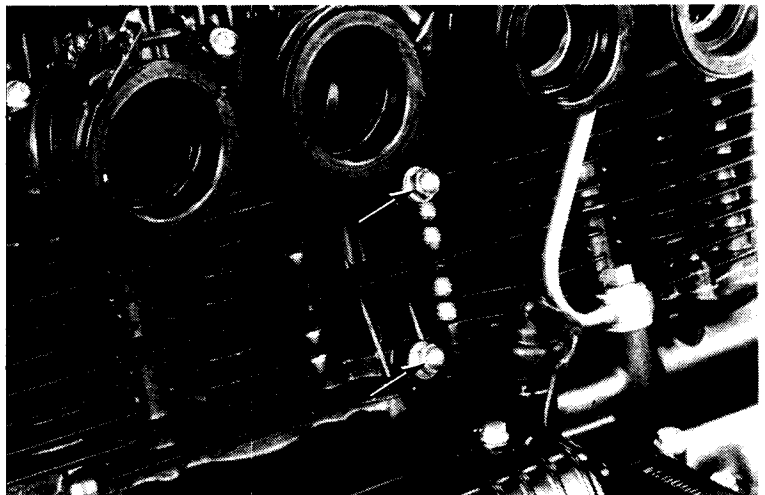



Remove the oil line bolts and oil line.

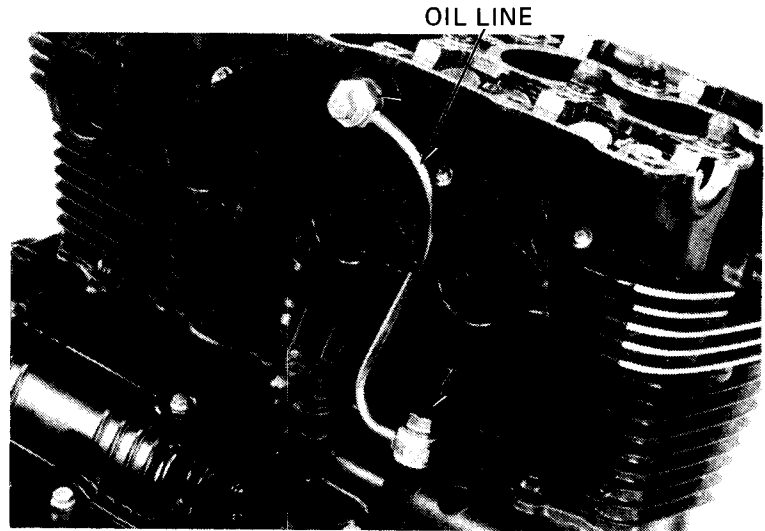

Remove the two bolts at the front cam chain housing.

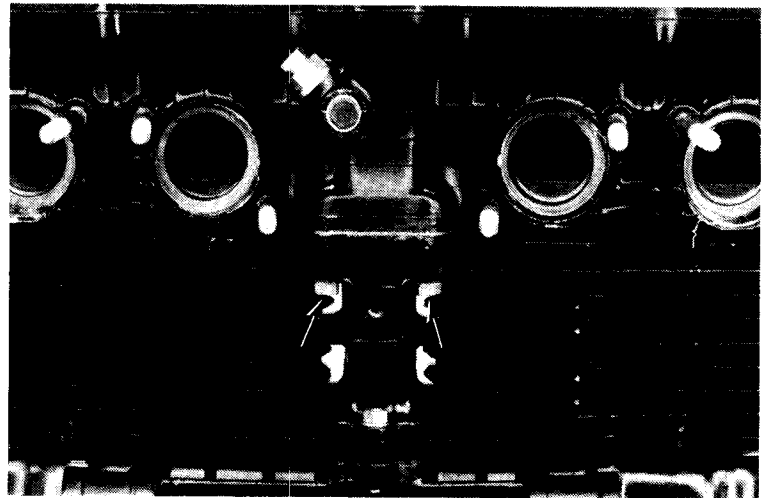

Remove the 12 cylinder head cap nuts.

NOTE:

Remove the nuts in 2-3 steps in a crisscross pattern to prevent warpage.

Remove the cylinder head.

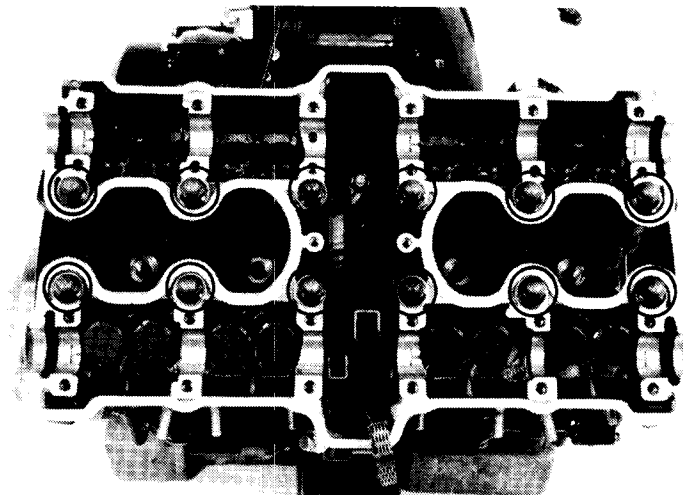



Remove the cylinder head gasket, dowel pins, and cam chain guide.

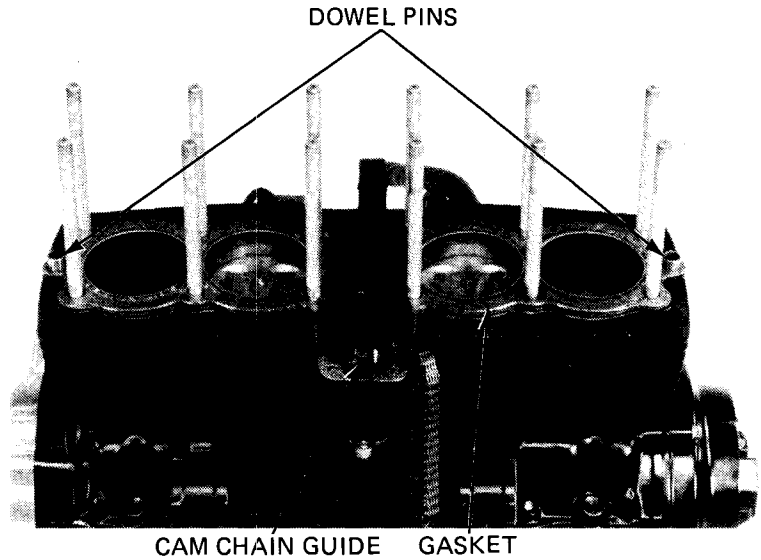

CYLINDER HEAD DISASSEMBLY

Remove the valve clearance adjusting shims and the valve lifters.

NOTE:

Mark all disassembled parts to ensure correct reassembly.

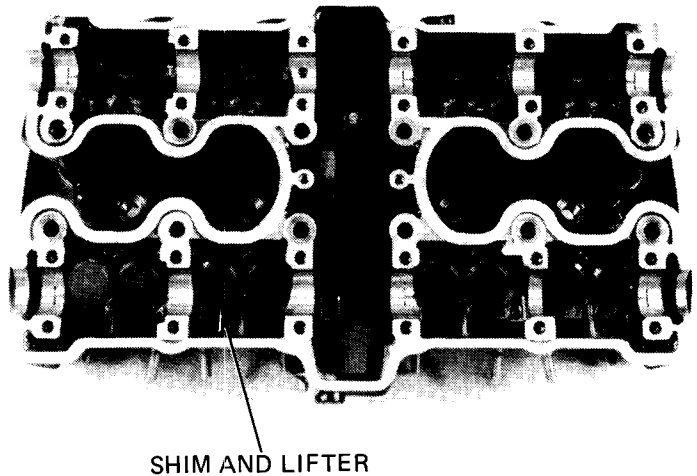

Loosen the cam chain tensioner lock nut and bolts. Remove the bolt in the cylinder head and pull the chain tensioner back and remove.

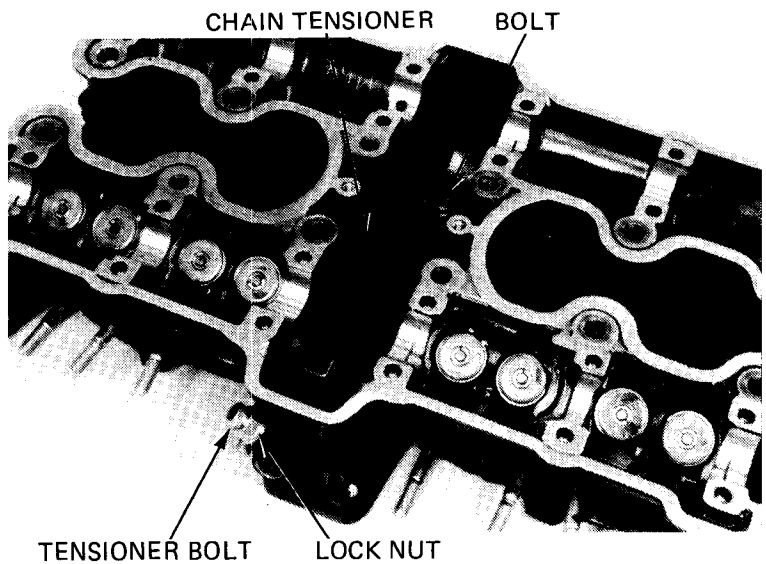



CYLINDER HEAD/VALVE

Remove the valve spring cotters, retainers, springs and valves.

CAUTION:

- Use the Valve lifter bore protector tool to prevent bore surface damage during valve disassembly.
- To prevent loss of tension, do not compress the valve springs more than necessary to remove the cotters.

NOTE:

Mark all disassembled parts for correct re-assembly.

Remove the valve stem seals.

Remove carbon deposits from the combustion chamber.
Clean off the head gasket surfaces.

NOTE:

- Avoid damaging the gasket surfaces.
- Gasket material will come off easier if soaked in solvent.

VALVE LIFTER BORE PRORECTOR
07999-4220000

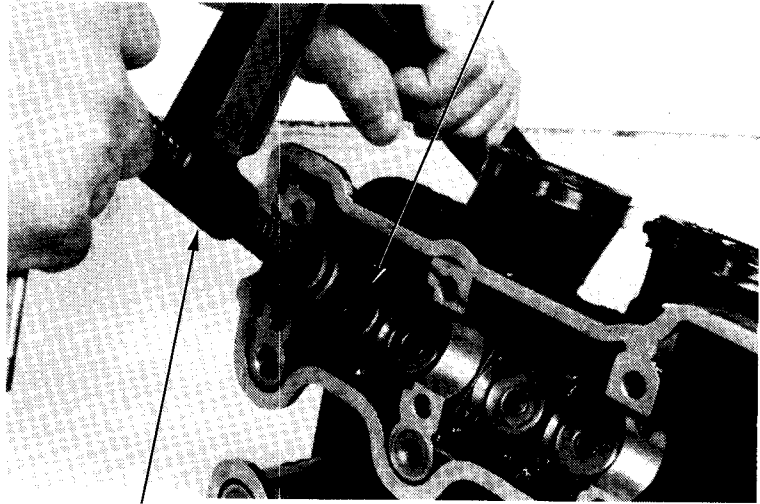

SPRING COMPRESSOR
07757-0010000

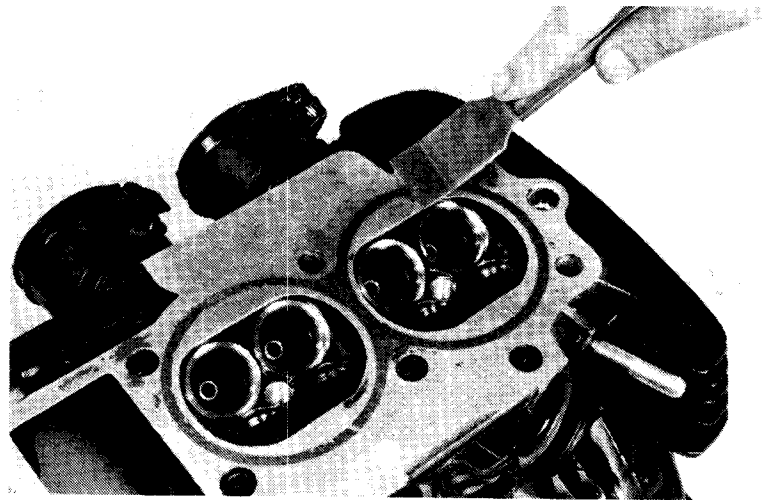

VALVE LIFTER O.D.

Measure valve filter O.D.

SERVICE LIMIT: 27.96 mm (1.101 in)

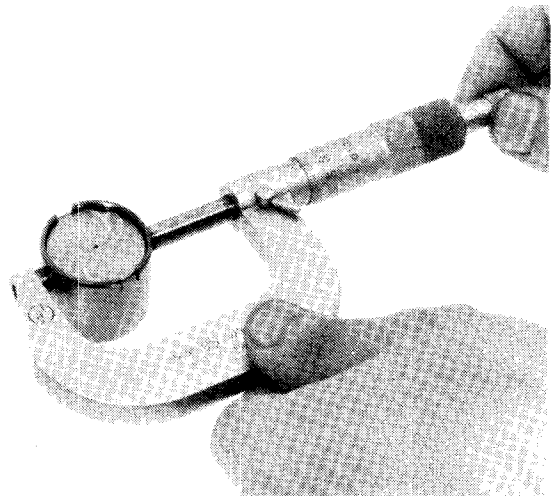



VALVE LIFTER BORE

Measure valve lifter bore I.D.

SERVICE LIMIT: 28.04 mm (1.1039 in)

Inspect the valve lifter for scoring, scratches, or evidence of insufficient lubrication.

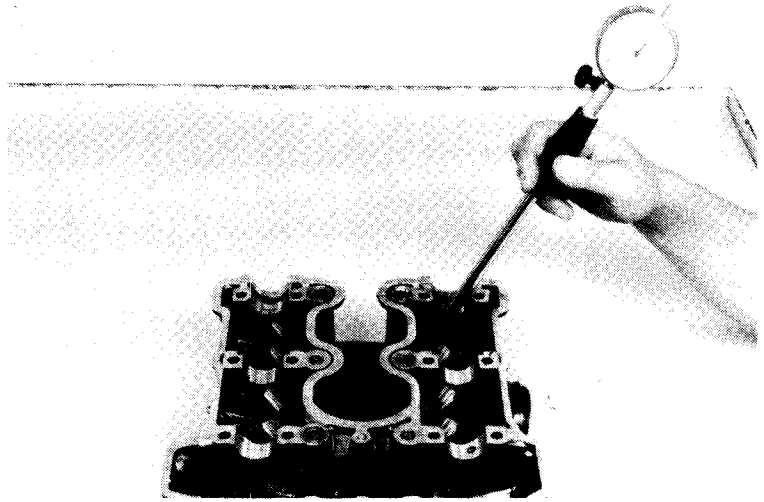

Check the spark plug hole and valve areas for cracks.

Check the cylinder head for warpage with a straight edge and a feeler gauge.

SERVICE LIMIT: 0.10 mm (0.0039 in)

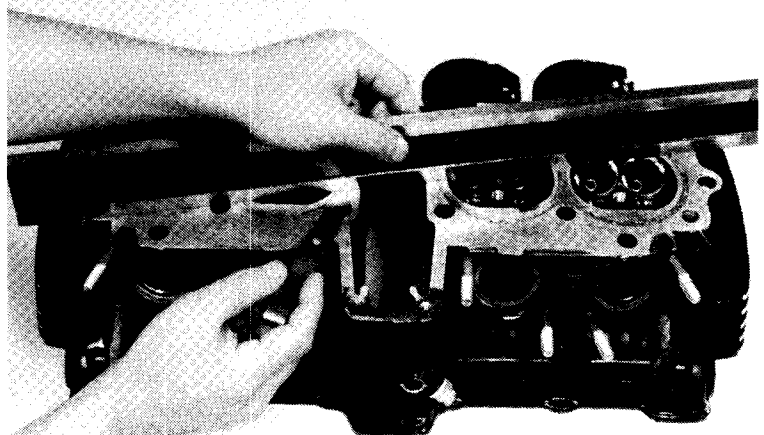

VALVE SPRING FREE LENGTH INSPECTION

Measure the length of the inner and outer valve springs.

SERVICE LIMITS:

Inner: IN/EX 38.5 mm (1.515 in)

Outer: IN/EX 42.7 mm (1.681 in)

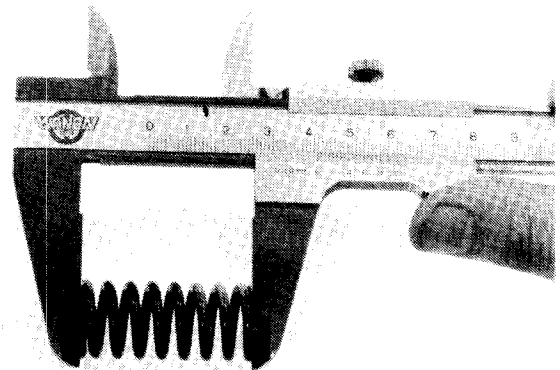



CYLINDER HEAD/VALVE

**VALVE STEM-TO-GUIDE
CLEARANCE**

Inspect each valve for bending, burning, scratches or abnormal stem wear.

Check valve movement in the guide.

Measure and record each valve stem O.D.

SERVICE LIMITS: IN: 5.47 mm (0.215 in)
EX: 5.44 mm (0.214 in)



NOTE:

Ream the guides to remove any carbon build-up before checking clearance.

Measure and record each valve guide I.D. using a ball gauge or inside micrometer.

SERVICE LIMIT: IN/EX. 5.54 mm (0.218 in)

Subtract each valve stem O.D. from the corresponding guide I.D. to obtain the stem to guide clearances.

SERVICE LIMITS: IN: 0.07 mm (0.003 in)
EX: 0.10 mm (0.004 in)

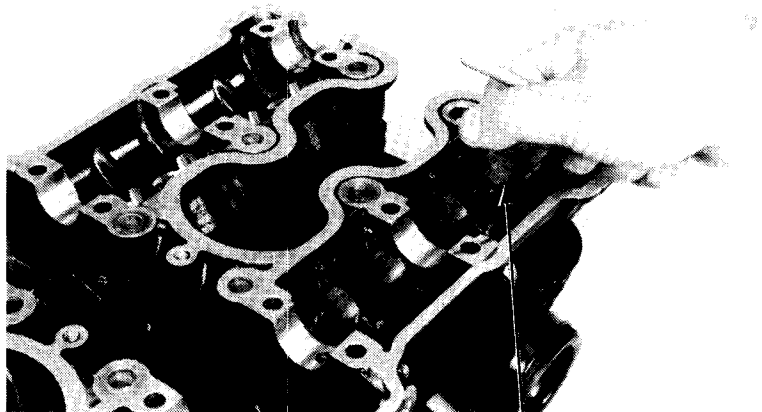

VALVE GUIDE REAMER
07984-2000000

In the stem-to-guide clearance exceeds the service limits, determine if a new guide with standard dimensions would bring the clearance within tolerance. If so, replace any guides as necessary and ream to fit.

If the stem-to-guide clearance exceeds the service limits with new guides, replace the valves.

NOTE:

Reface the valve seats whenever the valve guides are replaced (page 9-16).

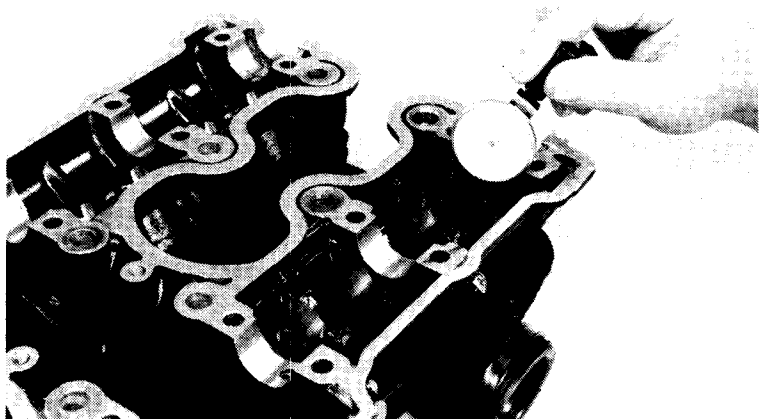



CAM CHAIN GUIDE AND CAM CHAIN TENSIONER INSPECTION

Inspect the cam chain guide for damage or excessive wear.

Inspect the cam chain tensioner slipper for damage or excessive wear.

Inspect the spring for tension.

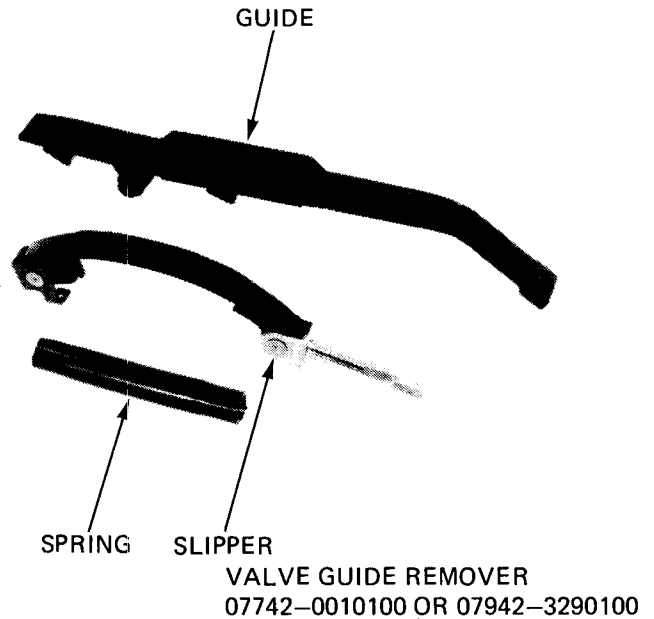

VALVE GUIDE REPLACEMENT

Support the cylinder head and drive out the guide from the valve port.

NOTE:

When driving out the valve guide, do not damage the head.

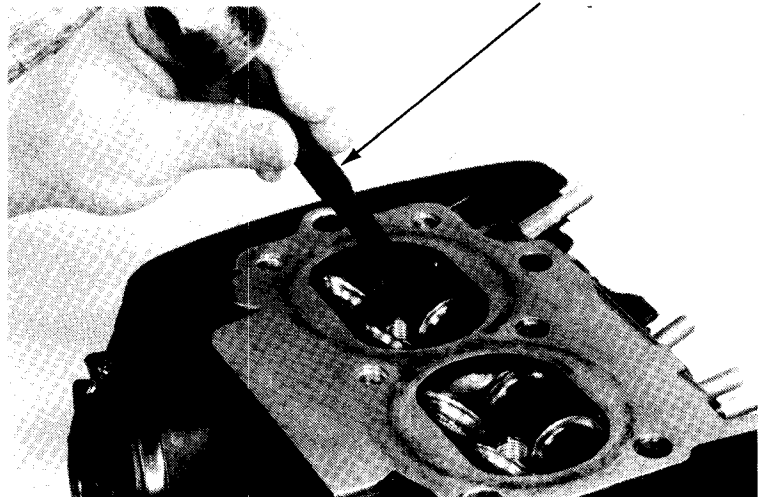

VALVE GUIDE DRIVER
07742-0020200 OR 07942-3290200

Install an oversize valve guide from the top of the head.





CYLINDER HEAD/VALVE

Ream the new valve guide after installation.

NOTE:

- Use cutting oil on the reamer during this operation.
- Rotate the reamer when inserting and removing it.

Reface the valve seat.

Clean the cylinder head thoroughly to remove any metal particles.

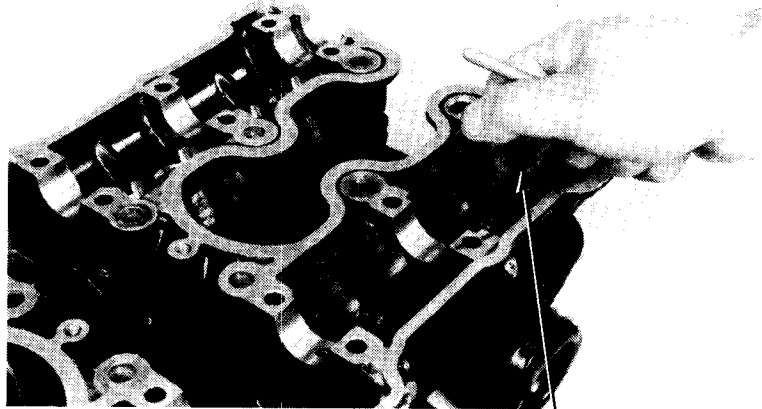

VALVE GUIDE REAMER
07984-2000000

VALVE SEAT INSPECTION/ REFACING

Clean all intake and exhaust valves thoroughly to remove carbon deposits.

Apply a light coating of valve lapping compound to each valve face. Lap each valve and seat using a rubber hose or other hand-lapping tool.

NOTE:

Take care not to allow the compound to enter between the valve stem and guide. After lapping, wash out the compound completely and apply a coat of engine oil to the valve face and seat.

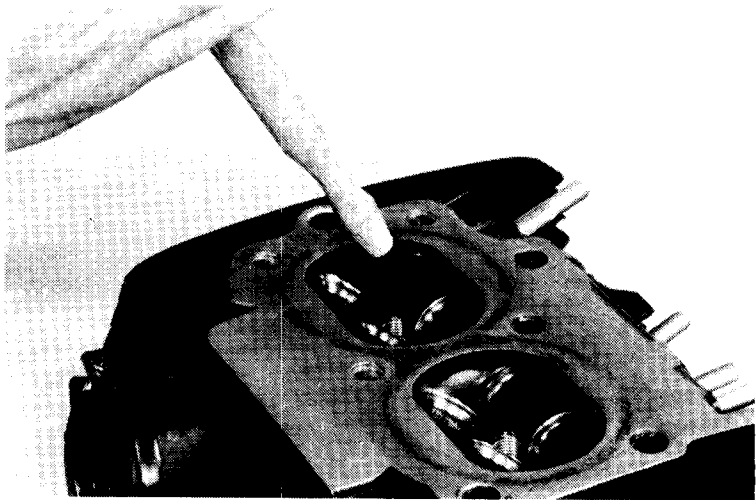

Remove the valve and inspect the face.

CAUTION:

The valves cannot be ground. If the valve face is rough, worn unevenly, or contacts the seat improperly, the valve must be replaced.

Inspect the valve seat.

If the seat is too wide, too narrow, or has low spots, the seat must be ground.

NOTE:

Follow the refacer manufacturer's operating instructions.

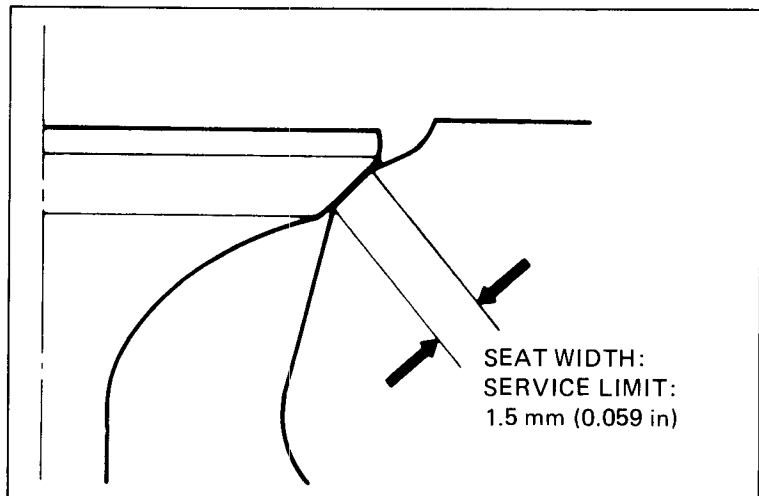



After cutting the seat, apply lapping compound to the valve face, and lap the valve using light pressure.

After lapping, wash any residual compound off the cylinder head and valve.

IN: CUTTER, 30 ϕ
EX: CUTTER, 28 ϕ

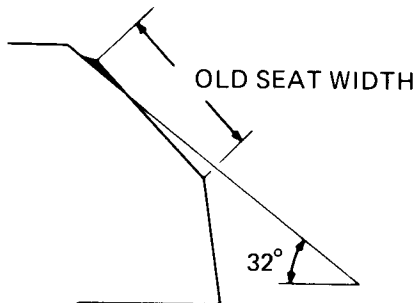

IN, EX: CUTTER, 30 ϕ

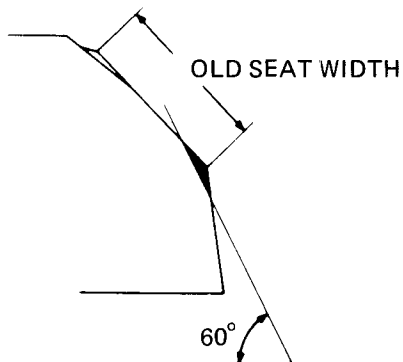

IN: CUTTER, 27.5 ϕ
EX: CUTTER, 24.5 ϕ

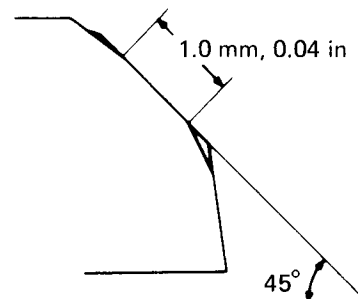

CYLINDER HEAD ASSEMBLY

Lubricate each valve stem with molybdenum disulfide grease and insert the valve into the valve guide.

NOTE:

- Install new valve stem seals when assembling.
- To avoid damage to the stem seal, turn the valve slowly when inserting.

Install the valve spring and retainers. The valve springs with the tightly wound coils should face the cylinder head.

Install the valve cotters.

CAUTION:

To prevent loss of tension, do not compress the valve springs more than necessary to install the valve cotters.

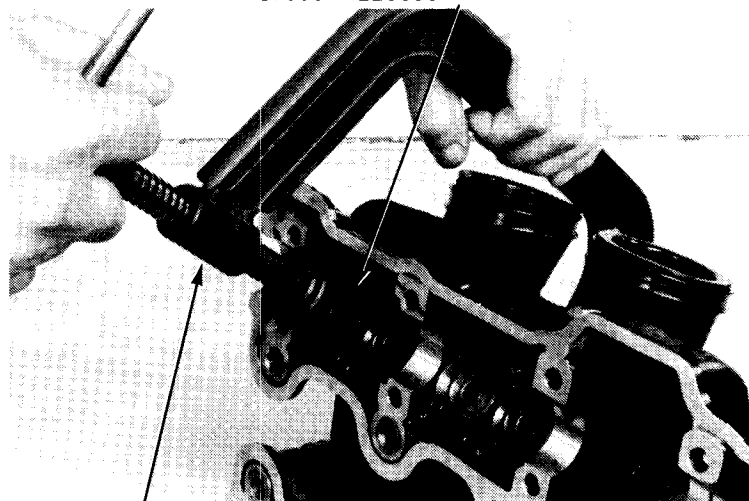
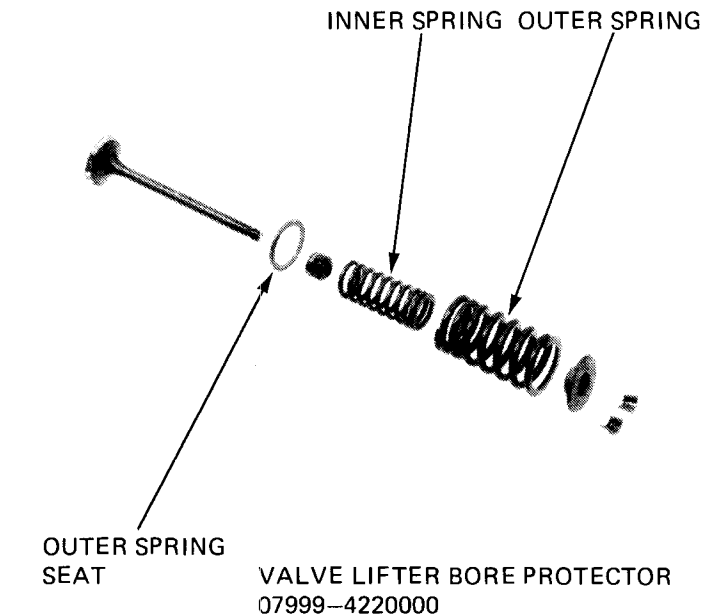

SPRING COMPRESSOR
07757-0010000



CYLINDER HEAD/VALVE

Tap the valve stems gently with a soft hammer to firmly seat the valve cotters.

NOTE:

Support the cylinder head above the work bench surface to prevent possible valve damage.

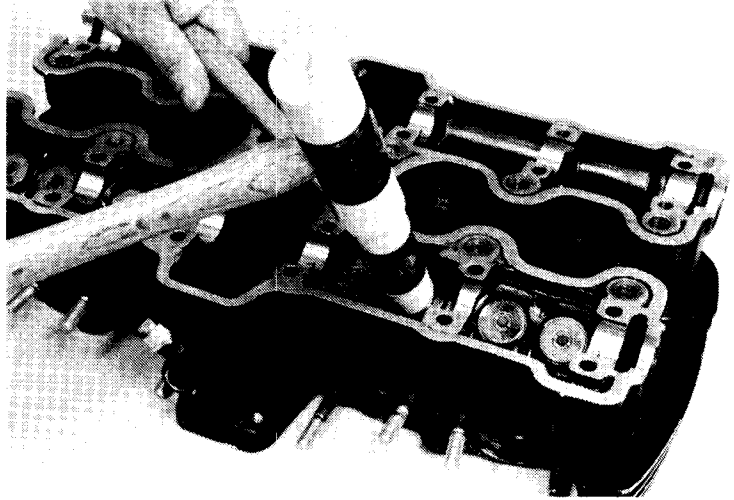

Install the front cam chain tensioner. Push the chain tensioner down and tighten the lock bolt and nut.

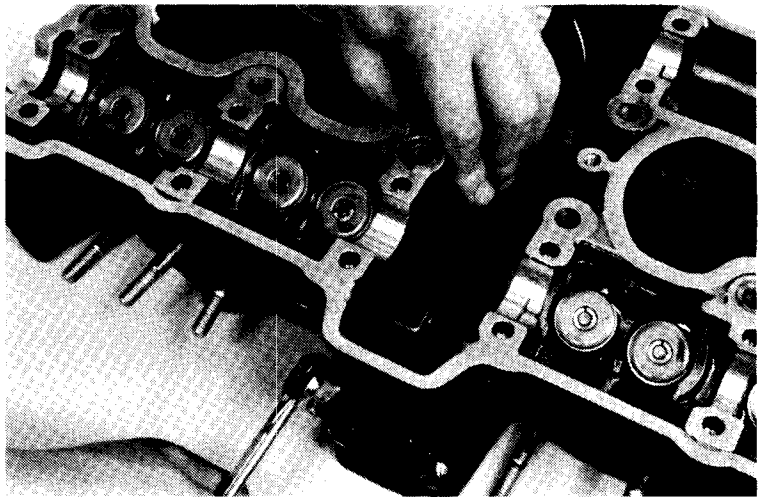

Install the valve lifters and adjustment shims.

NOTE:

Make sure that the valve lifters and shims are in their original position.

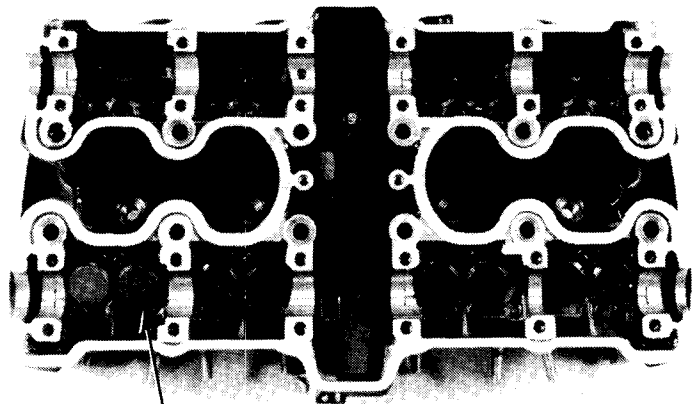

SHIM AND LIFTER



CYLINDER HEAD INSTALLATION

Clean the cylinder head surfaces of any gasket material.

Install the dowel pins and the cam chain guide. Install a new cylinder head gasket with the 5 mm wide side of the bore grommet up.

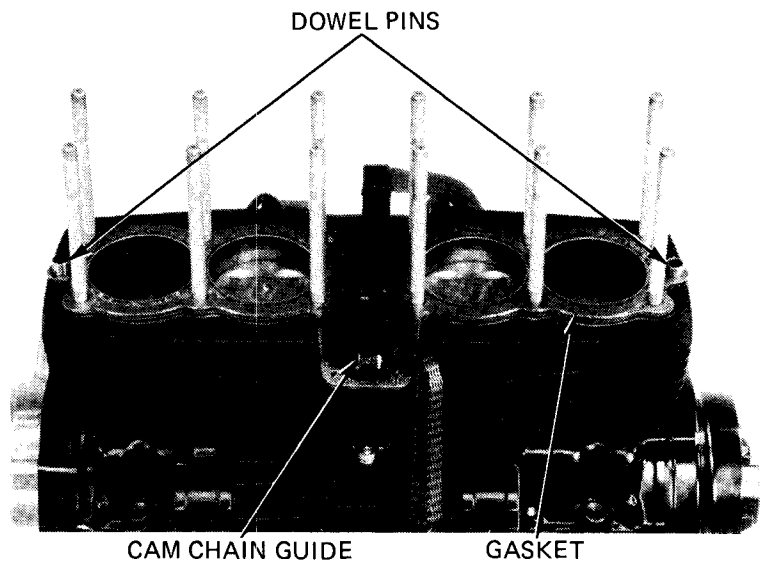

Install the two cam chain tensioner lock nuts loosely.

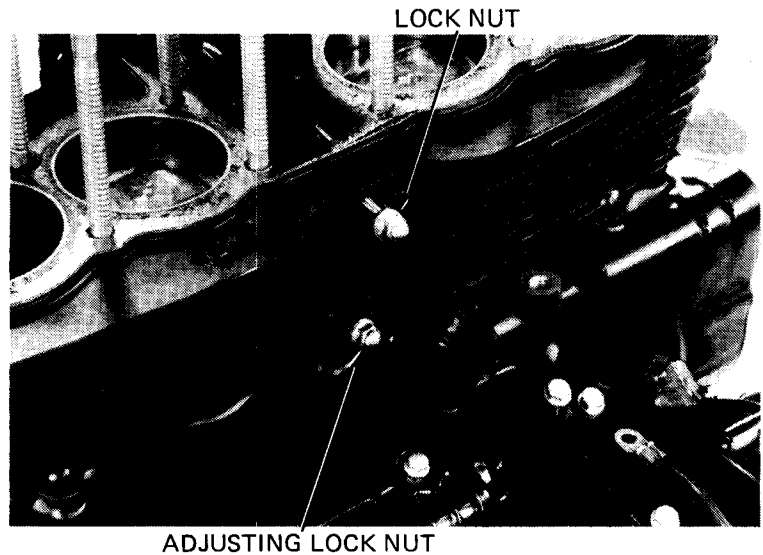

Install the cylinder head assembly. Tighten the cap nuts in the sequence shown.

TORQUE:

10 mm cap nut: 36–40 N·m (3.6–4.0 kg·m, 26–29 ft·lb)

NOTE:

Apply molybdenum disulfide grease to the threads of the cylinder bolts.

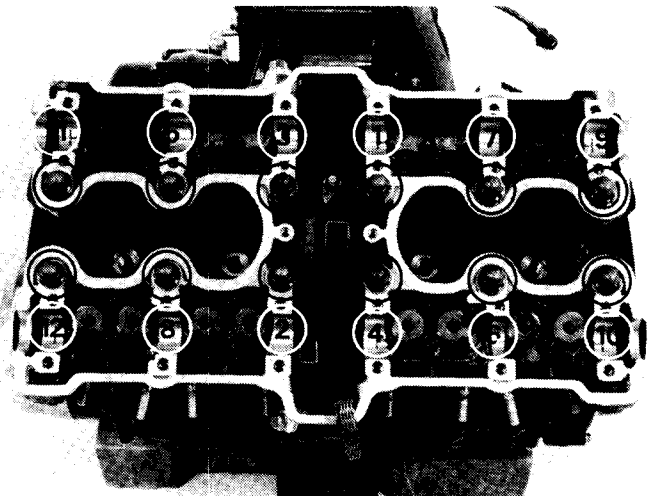



CYLINDER HEAD/VALVE

Tighten the two bolts at the front cam chain housing.

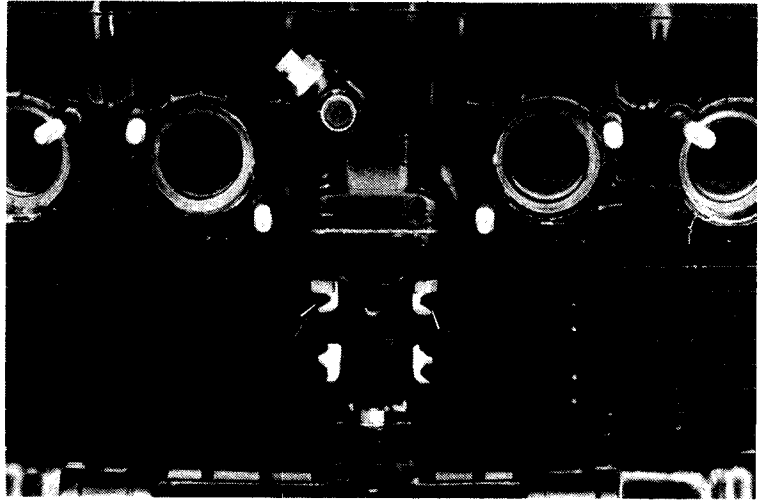

Install the oil cooler hose setting plate and tighten the two oil line bolts.

NOTE:

Use the bolt with the big hole to tighten the upper oil line.

TORQUE: 21–25 N·m (2.1–2.5 kg·m, 15–18 ft·lb)

UPPER (CYLINDER HEAD) SIDE

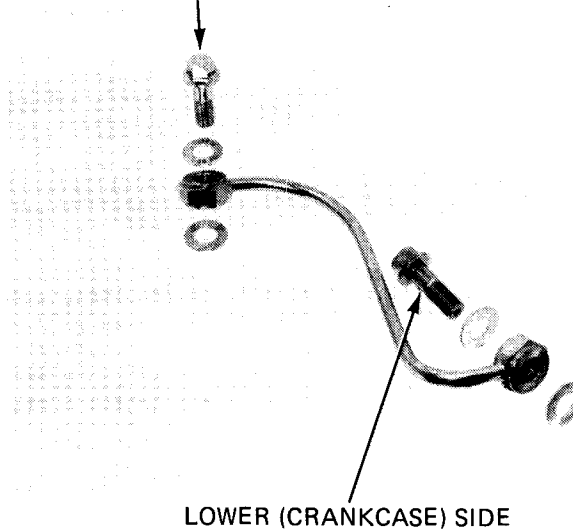

CAMSHAFT INSTALLATION

Lubricate the camshaft bearings with molybdenum disulfide grease.

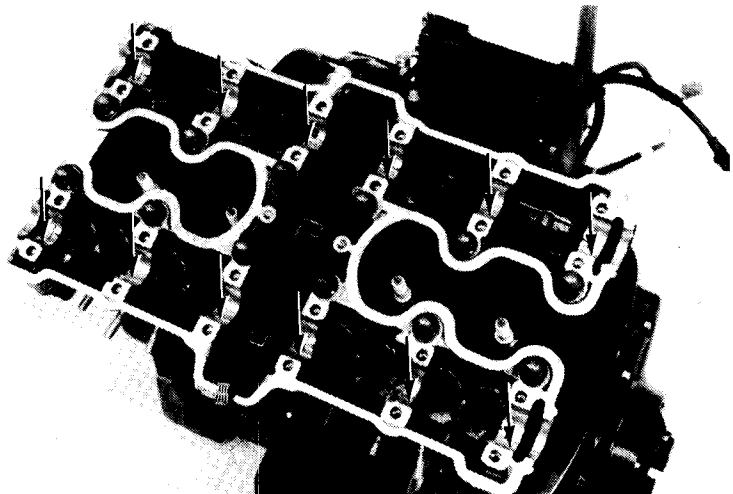



Turn the crankshaft counterclockwise until the "1.4T" and index marks align.

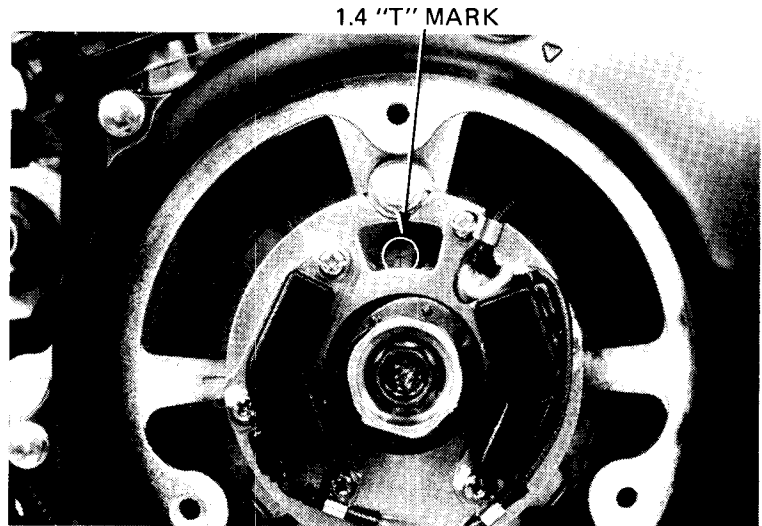

Push the rear cam chain tensioner rearward to provide maximum cam chain slack. Tighten the rear lock nuts.

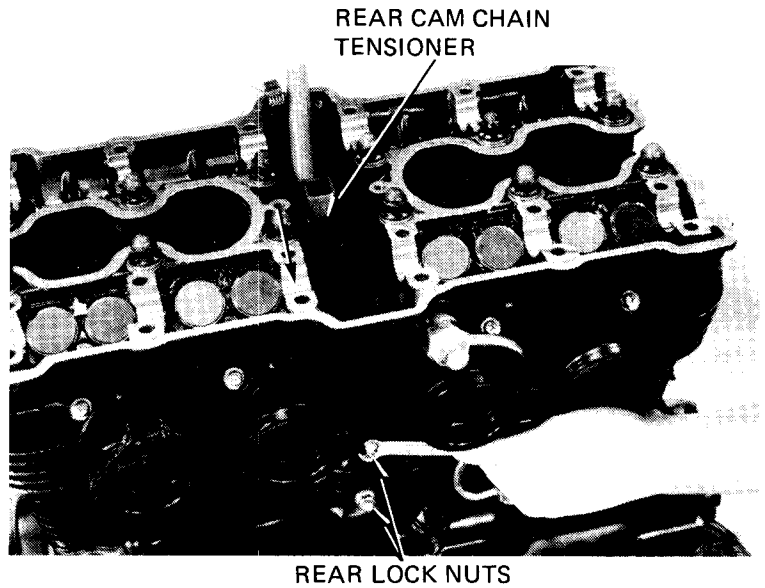

Place the intake and exhaust cam chains over the exhaust camshaft sprocket, aligning the sprocket punch marks with the cylinder head surface.

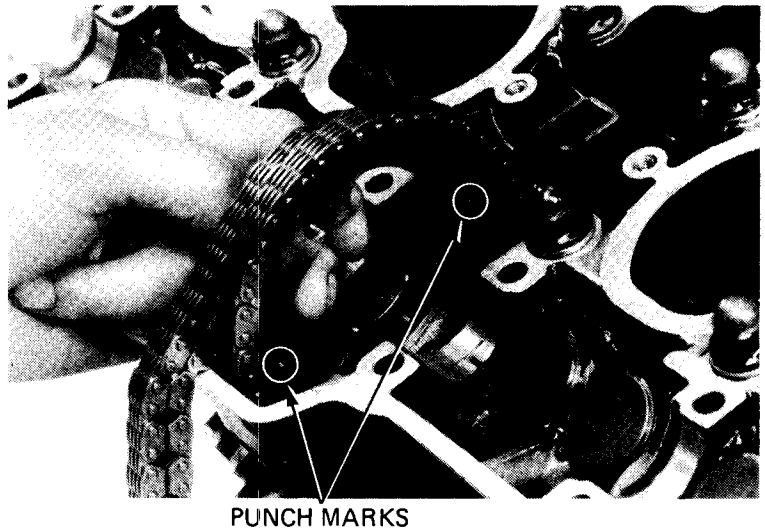



CYLINDER HEAD/VALVE

Turn the crankshaft 180° and place the exhaust camshaft through the exhaust camshaft sprocket.

Realign the 1.4 "T" mark with index mark. Position the No. 1 (or 4) cam lobes towards the spark plug.

Install the A and E camshaft holders loosely.

NOTE:

Install all camshaft holders with directional arrows pointing towards the front of the engine.

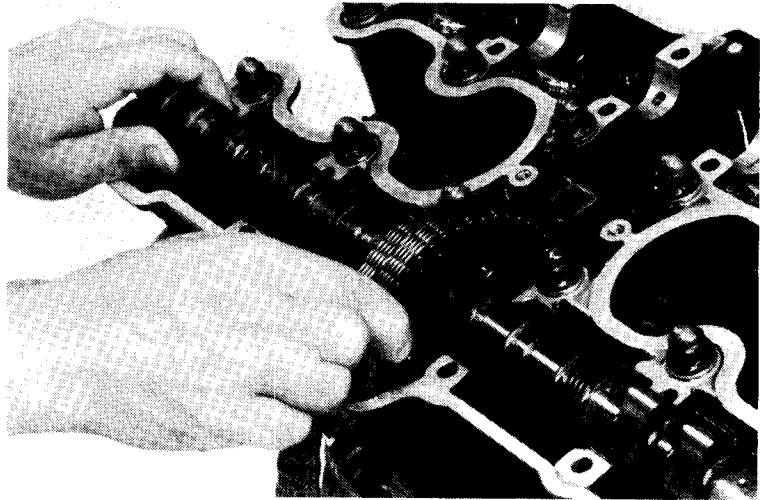

Loosely install the D camshaft holder and the tachometer drive gear/camshaft holder. Position the camshaft so its flange fits into the D holder slot.

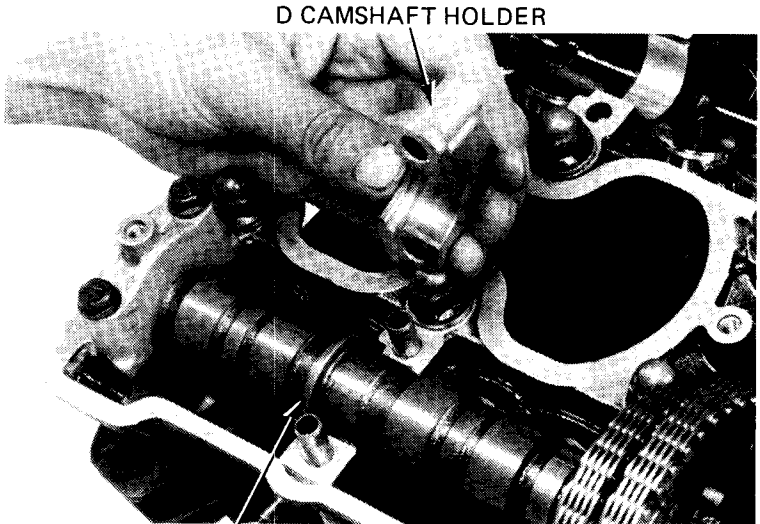

Position the camshaft sprocket over the exhaust camshaft shoulder and install the cam sprocket bolt.

Turn the crankshaft counterclockwise 360° and install the other camshaft sprocket bolt and tighten to the specified torque. Turn the crankshaft another 360° and tighten the sprocket bolt which was installed earlier.

TORQUE: 18–20 N·m (1.8–2.0 kg·m, 13–15 ft·lb)

Tighten the camshaft holder bolts in a crisscross pattern.

TORQUE: 12–16 N·m (1.2–1.6 kg·m, 9–12 ft·lb)

Make sure that the "1.4T" and index marks are aligned as shown on page 9-21 and the No. 1 (or 4) cam lobes face toward the spark plug. Recheck the position of the exhaust camshaft sprocket; the punch marks must align with the cylinder head surface.

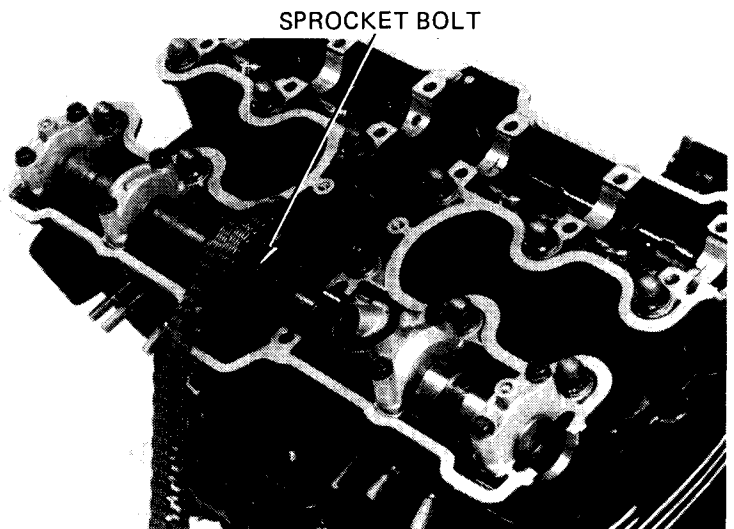



Place the intake cam chain over the intake camshaft and sprocket, aligning the sprocket punch marks with the cylinder head surface.

Install the intake camshaft, positioning the cam lobes for the No. 1 (or 4) cylinder toward the spark plugs. Install a camshaft sprocket bolt, but do not tighten yet.

NOTE:

If the sprocket was not removed from the camshaft during disassembly, then reinstall as an assembled set.

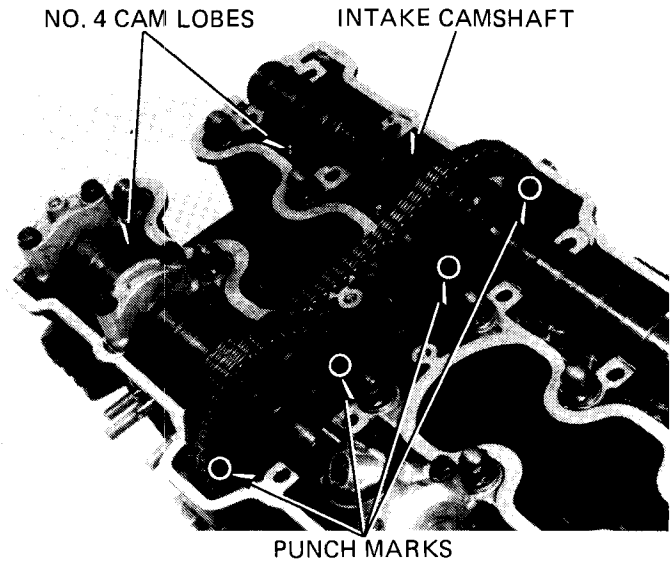

Loosely install the F and L camshaft holders. Install the G and K holders loosely, positioning the camshaft so its flange fits into the slot in the K holder.

Install and tighten the camshaft sprocket bolts, following the same procedures described for exhaust camshaft installation.

Tighten the camshaft holder bolts in a crisscross pattern.

Recheck the crankshaft and camshaft sprocket alignment.



Install the exhaust cam chain guide plate and oil pool caps.

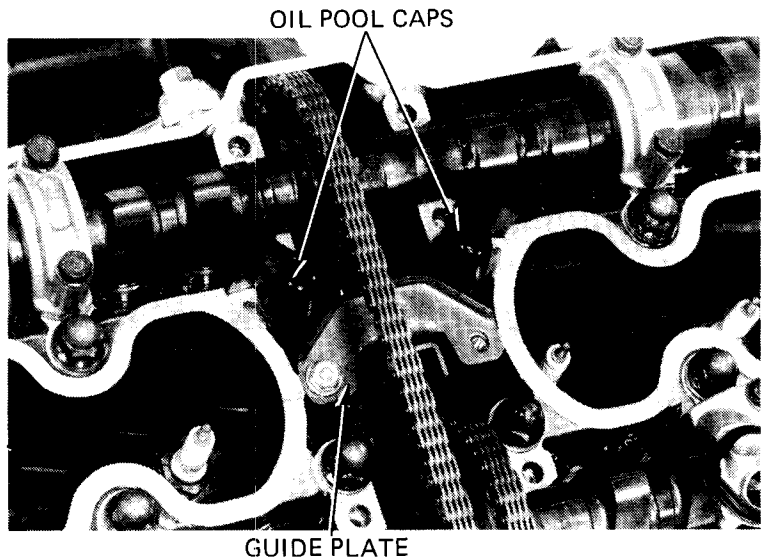



CYLINDER HEAD/VALVE

Install the oil line and cam chain guide with the B, C, H and J holders. Tighten in a crisscross pattern.

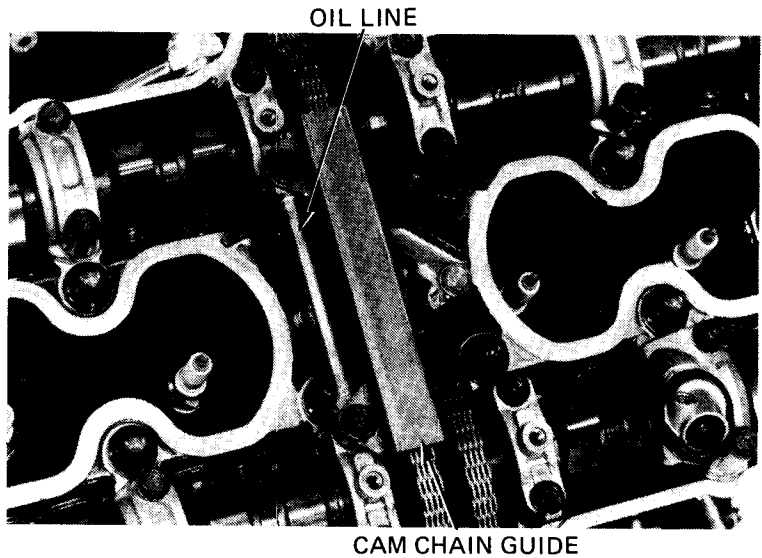

Fill the oil pockets in the head with oil so that the cam lobes are submerged.

Adjust the valve clearance (page 3-8).

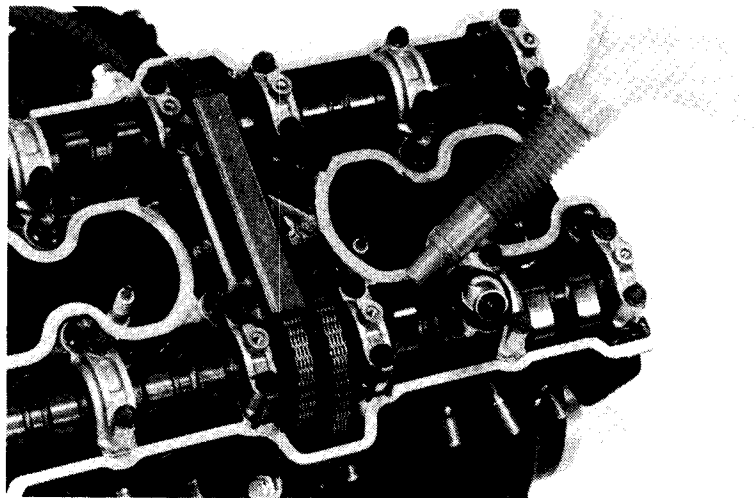

Inspect the cylinder head cover gasket for damage or deterioration.

Apply a sealant on the cylinder gasket at eight places as shown.

NOTE:

Clean the gasket before applying sealant.

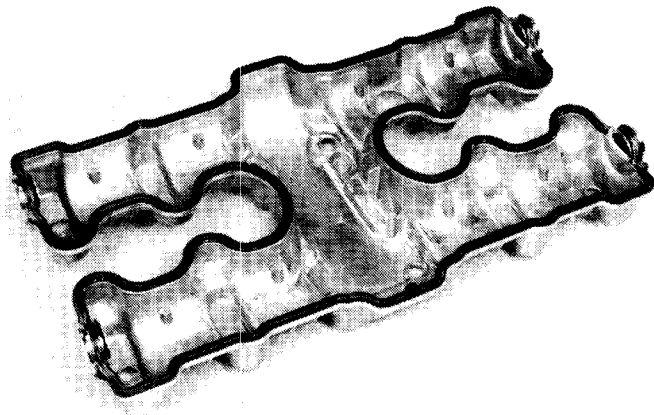



Install the cylinder head cover.

Connect the tachometer cable.
Install the spark plug caps.

Install the pulse generator cover.

Adjuster cam chain tension (page 3-12).

