

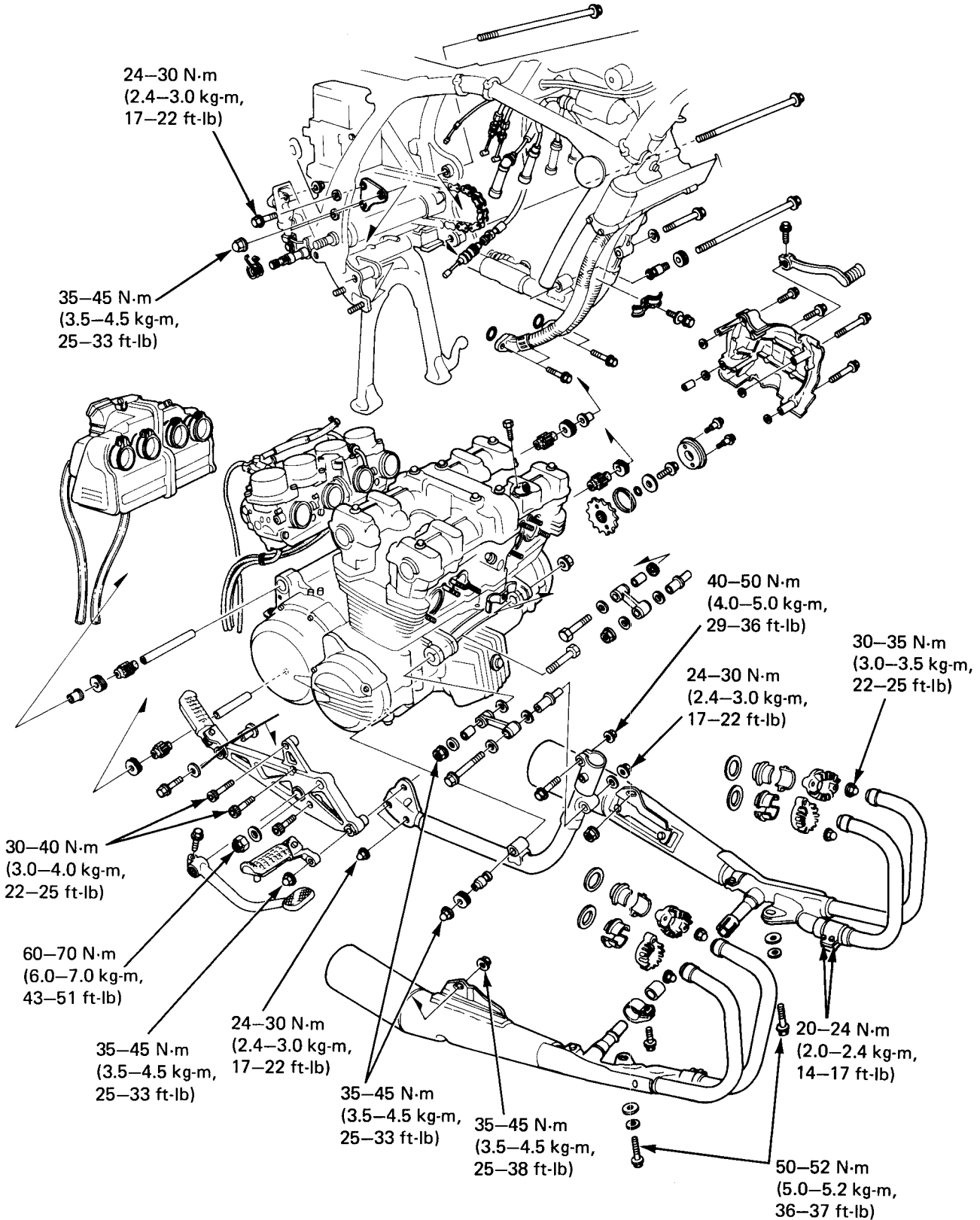

**ENGINE REMOVAL/INSTALLATION**





SERVICE INFORMATION	5-1
ENGINE REMOVAL	5-2
ENGINE INSTALLATION	5-7

## SERVICE INFORMATION

### GENERAL

- The following parts or components can be serviced with the engine in the frame:

- |                      |                 |
|----------------------|-----------------|
| • Clutch             | • Alternator    |
| • Gear shift linkage | • Starter motor |
| • Camshaft           | • Carburetor    |

### SPECIFICATIONS

Engine dry weight	92 kg (203 lb)
Oil capacity	4.5 lit (4.7 US qt) at engine assembly 3.5 lit (3.7 US qt) at change

### TORQUE VALUES

Engine mounting bolt	
10 mm bolt (1)	35-45 N·m (3.5-4.5 kg-m, 25-33 ft-lb)
10 mm bolt (2)	40-50 N·m (4.0-5.0 kg-m, 29-36 ft-lb)
Rear axle nut	80-100 N·m (8.0-10.0 kg-m, 58-72 ft-lb)
Swingarm pivot nut	60-70 N·m (6.0-7.0 kg-m, 43-51 ft-lb)
Rear brake master cylinder mounting bolt	30-40 N·m (2.0-4.0 kg-m, 22-29 ft-lb)
Exhaust pipe cap nuts	30-35 N·m (3.0-3.5 kg-m, 22-25 ft-lb)
Exhaust pipe oil pan mount bolts	50-52 N·m (5.0-5.2 kg-m, 36-37 ft-lb)
Rear muffler mounting bolts	35-45 N·m (3.5-4.5 kg-m, 25-33 ft-lb)
Exhaust pipe connecting band bolts	20-25 N·m (2.0-2.5 kg-m, 14-18 ft-lb) Apply grease



## ENGINE REMOVAL

Place the motorcycle on its center stand.

Drain the engine oil.

Remove the seat, fuel tank, left and right side covers.

Remove the exhaust pipe-to-oil-pan mounting bolts.

Loosen the exhaust pipe connecting band bolts.

CONNECTING BAND BOLTS

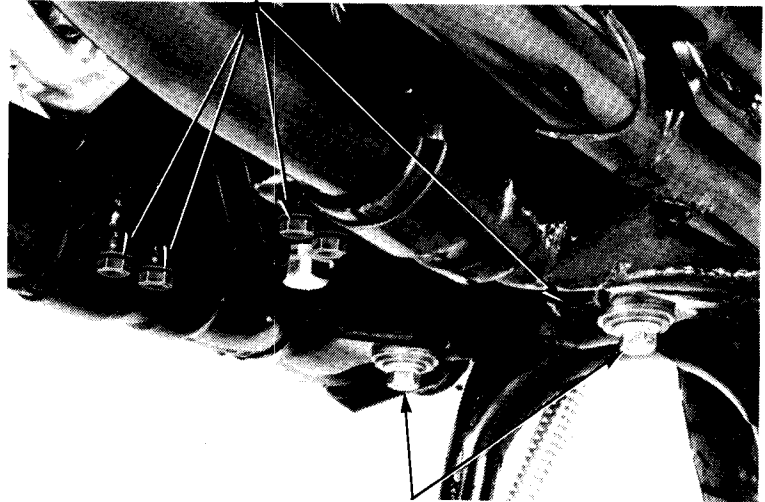

EXHAUST-TO-OIL PAN BOLTS

Remove the exhaust pipe cap nuts.  
Remove the muffler rear mounting bolts and remove the exhaust system.

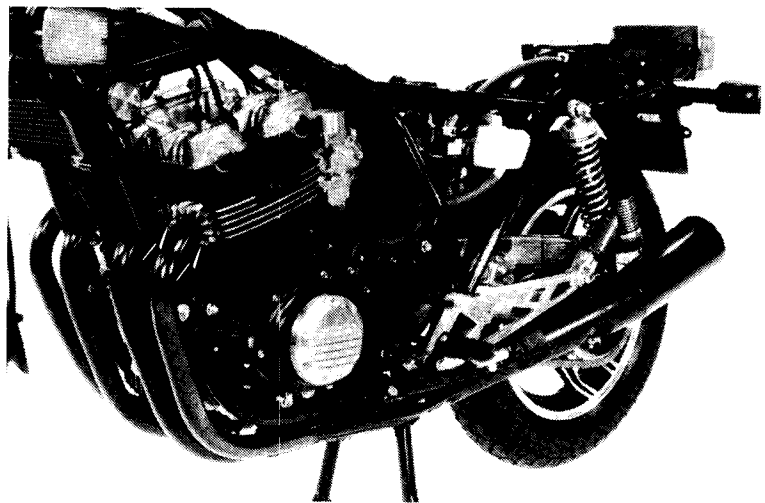

Disconnect the oil cooler hoses from the engine.  
Remove the oil cooler hose clamp bolts and clamps.

OIL COOLER HOSES

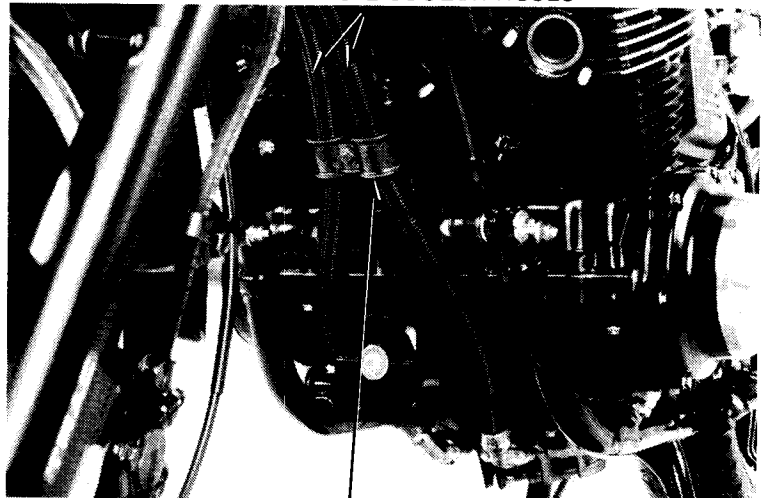

OIL COOLER HOSE CLAMP



Disconnect the ground cable from the battery and frame.  
Disconnect the alternator coupler.

GROUND CABLE

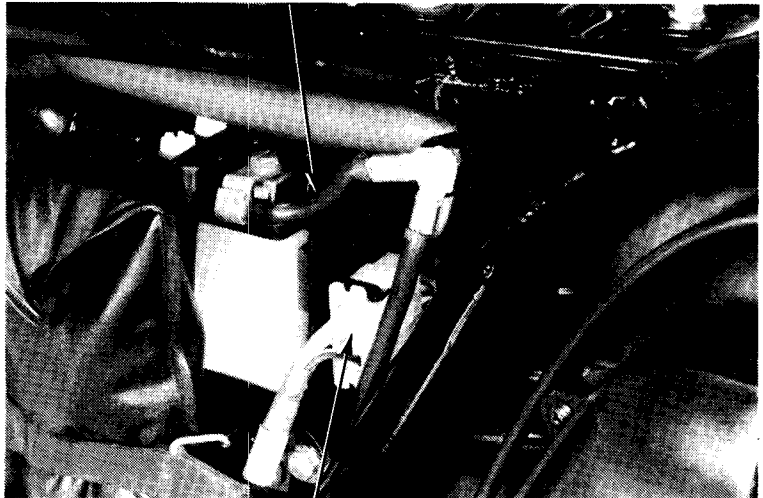

ALTERNATOR COUPLER

Disconnect the clutch cable at its lower end.

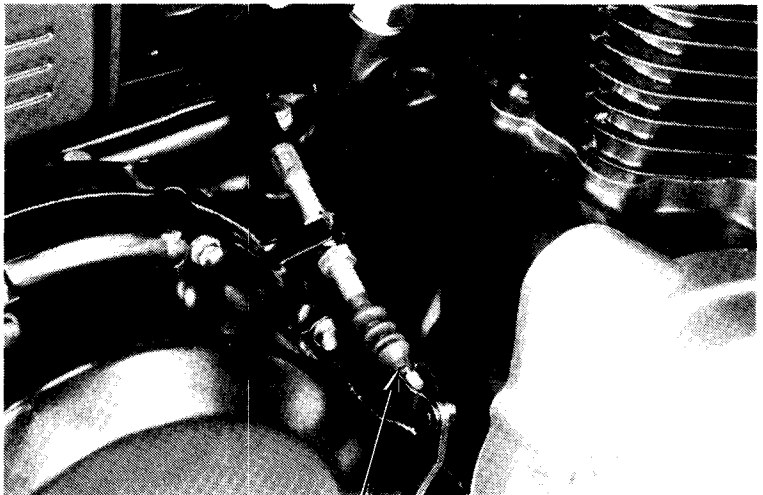

CLUTCH CABLE

Remove the brake pedal bolt and pedal.

BOLT

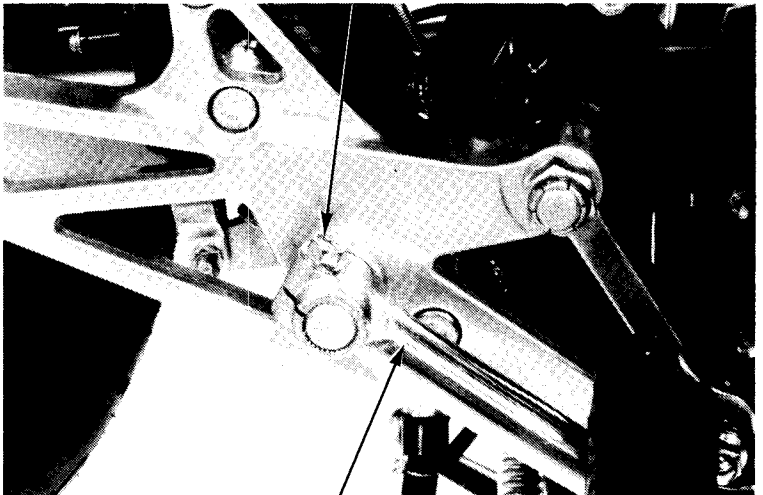

BRAKE PEDAL



**ENGINE REMOVAL/INSTALLATION**

Remove the air cleaner assembly and carburetors (page 4-3).

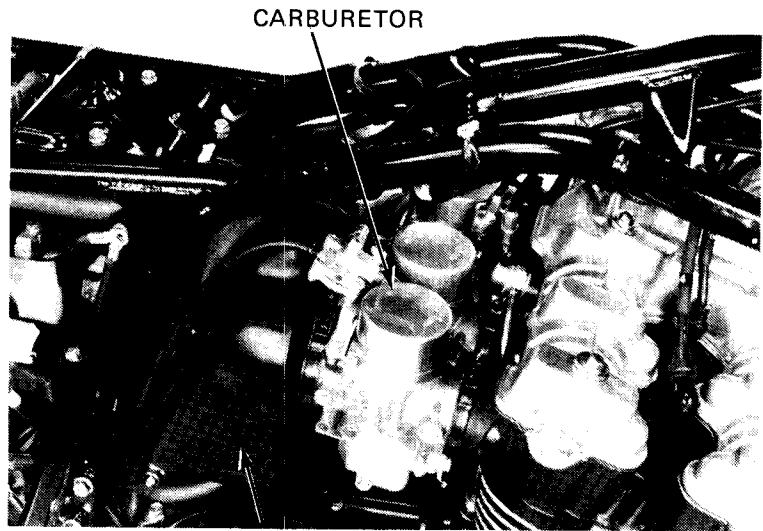

Disconnect the tachometer cable and spark plug caps.

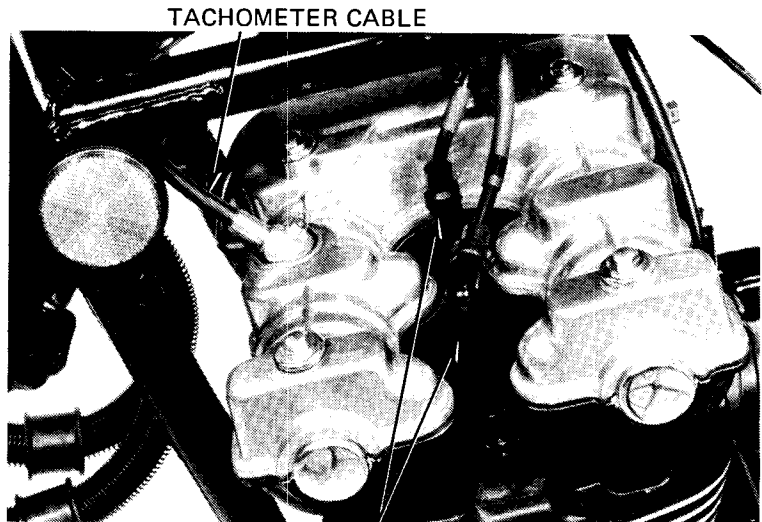

Disconnect the starter motor cable, pulse generator coupler and breather tube.

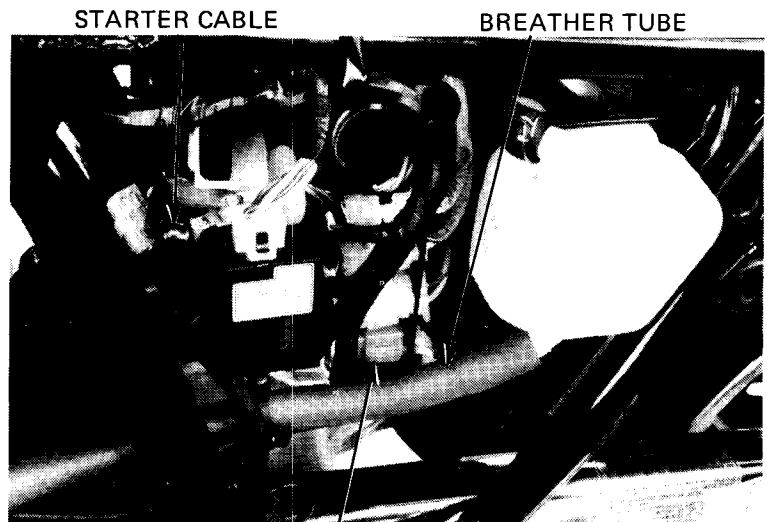



Loosen the lock nuts on both adjusters.  
Loosen the rear axle nut.  
Push the rear wheel forward.

**REAR AXLE NUT**

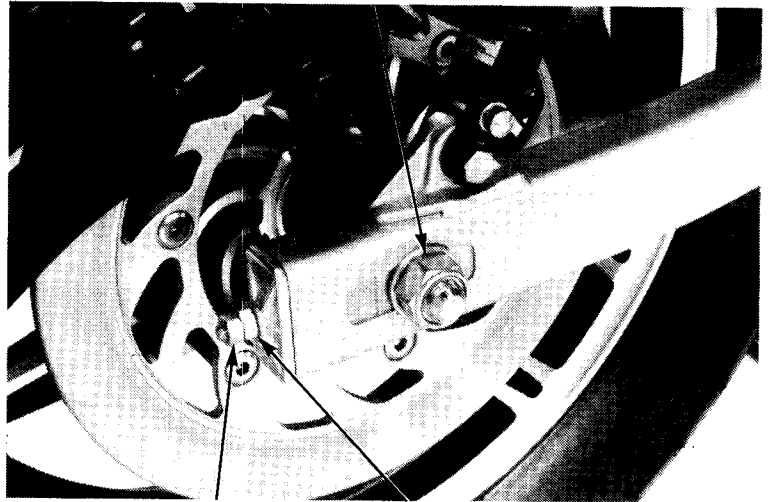

**LOCK NUT    ADJUSTING NUT**

Remove the gearshift pedal and the drive sprocket cover.

**DRIVE SPROCKET COVER**

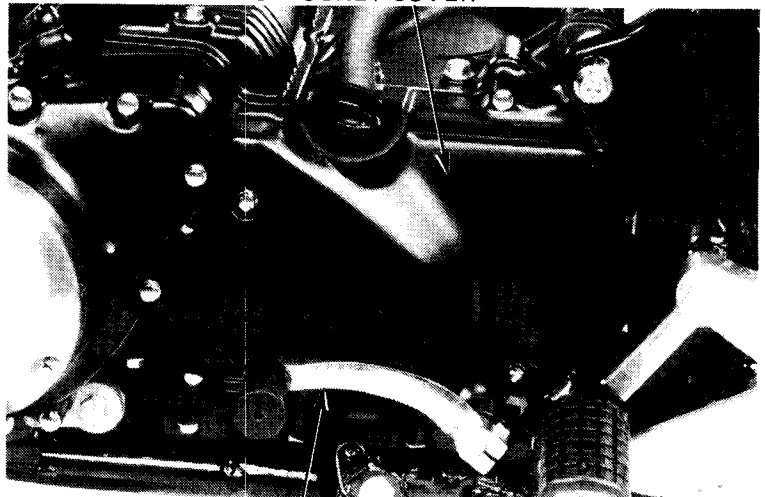

**GEAR SHIFT PEDAL**

Remove the drive chain guide plate.  
Remove the sprocket damper mounting bolts, damper plate and damper rubber.  
Remove the sprocket attaching bolt and sprocket.

**DRIVE CHAIN GUIDE PLATE**

**DRIVE CHAIN**

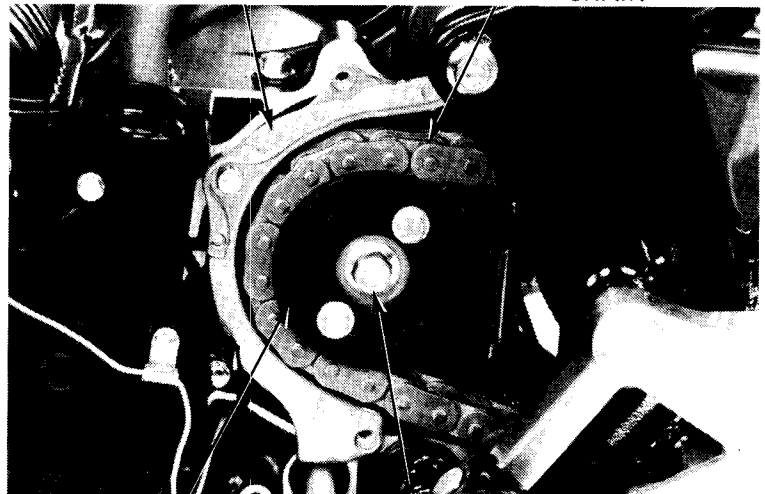

**DAMPER PLATE**

**SPROCKET ATTACHING BOLT**



**ENGINE REMOVAL/INSTALLATION**

Remove the rear brake master cylinder mounting socket bolts.

Remove the brake pedal bracket mounting socket bolt and swingarm pivot nut.

Remove the right foot peg.

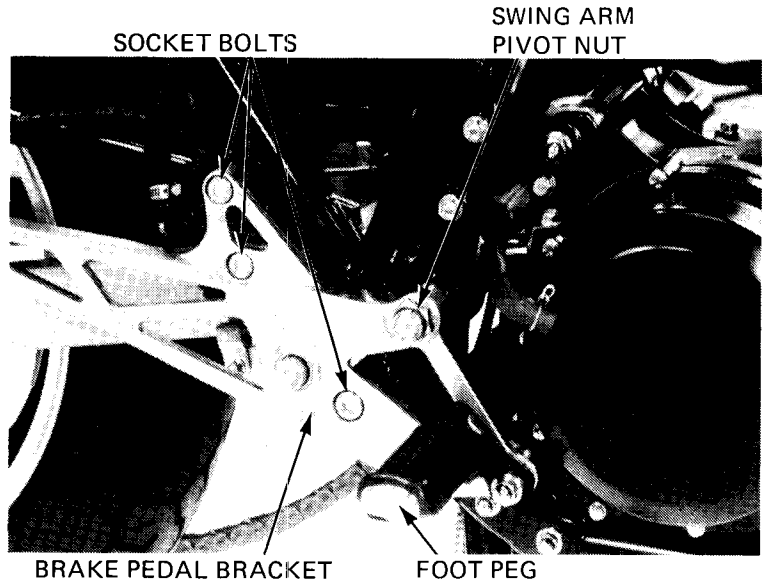

Pull the rear brake pedal bracket out.  
Place a jack under the engine.

Remove the right and left front engine mounting brackets.  
Remove the lower front and rear engine mounting bolts. Note the position of the outer damper plates.

Remove the rear engine mounting bolt.

Remove the lower right frame tube and remove the engine from the right side.

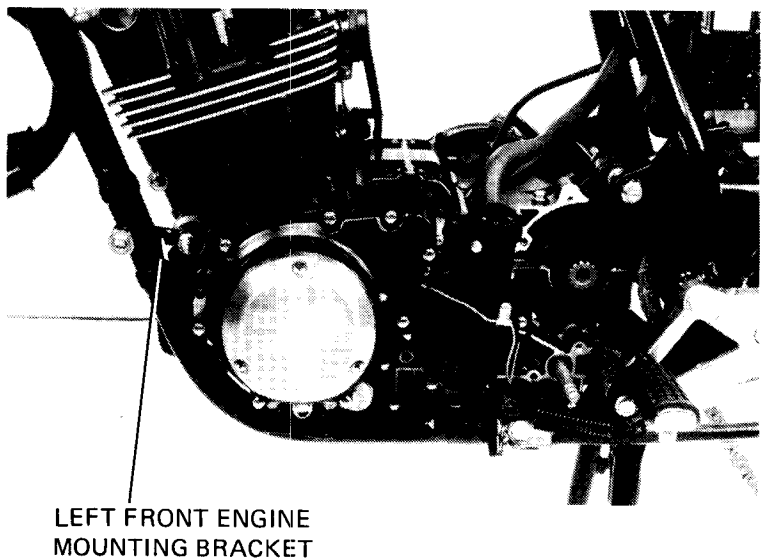
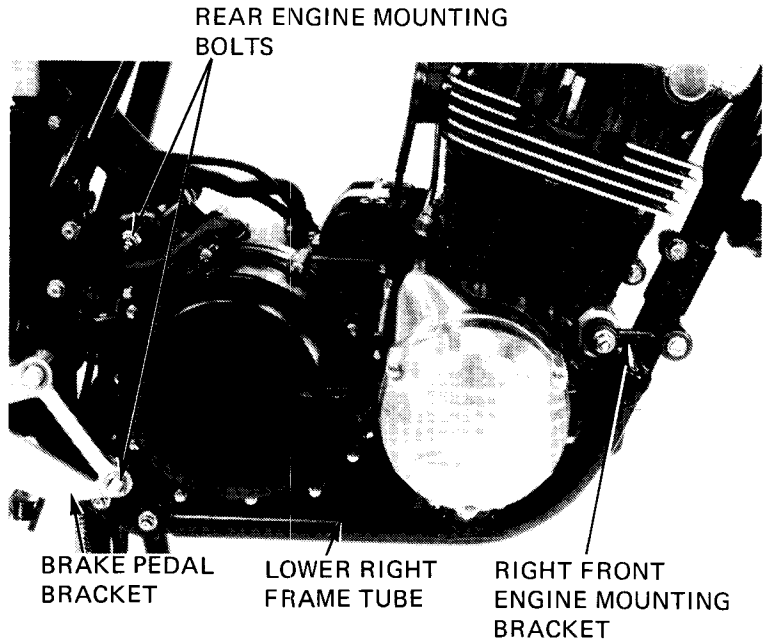



**ENGINE INSTALLATION**

Check the engine mounting rubbers for damage and replace if necessary.

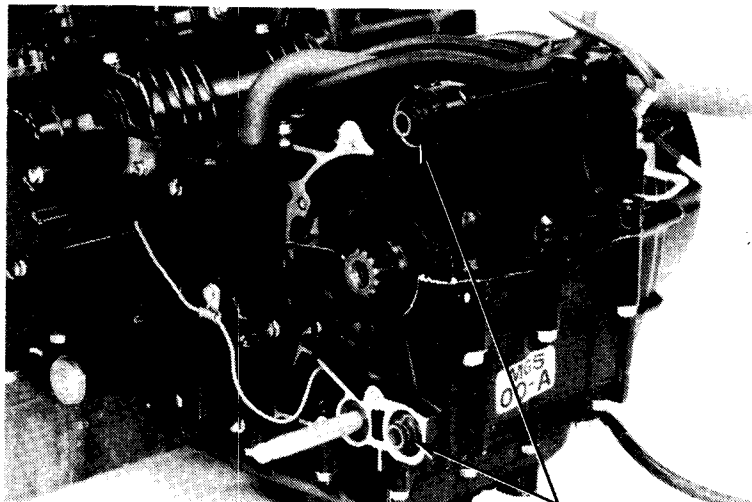

MOUNTING RUBBERS

Install the engine into the frame. Installation is essentially the reverse order of removal with these exceptions:

Position the lower front and rear engine mount outer damper plates as noted during removal. They must be positioned correctly for low vibration levels.

**TORQUE:**

**Engine hanger bolts:**

10 mm bolt (1): 35–45 N·m  
(3.5–4.5 kg-m, 25–33 ft-lb)

10 mm bolt (2): 40–50 N·m  
(4.0–5.0 kg-m, 29–36 ft-lb)

8 mm bolt: 24–30 N·m  
(2.4–3.0 kg-m, 17–22 ft-lb)

Swingarm pivot: 60–70 N·m  
(6.0–7.0 kg-m, 43–51 ft-lb)

Master cylinder bolt: 30–40 N·m  
(3.0–4.0 kg-m, 22–25 ft-lb)

Lower right frame tube pinch bolt: 40–50 N·m  
(4.0–5.0 kg-m, 29–36 ft-lb)

Lower right frame mount bolts: 24–30 N·m  
(2.4–3.0 kg-m, 17–22 ft-lb)

Note the "R" and "L" mark on the front engine mounting brackets.

MASTER CYLINDER BOLTS 10 mm BOLT (1) FRAME PINCH BOLT



SWINGARM PIVOT 10 mm BOLT (2) 8 mm BOLT NUT

"R" MARK "L" MARK

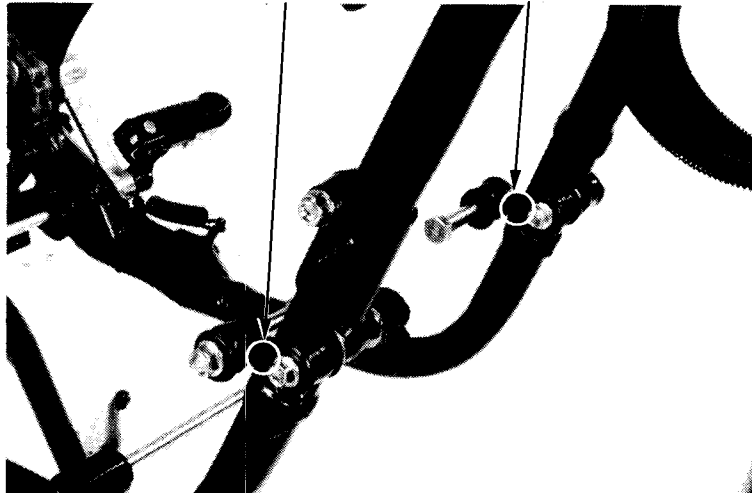



**ENGINE REMOVAL/INSTALLATION**

Check the drive sprocket O-ring and rubber damper for damage and replace if necessary.

Then install the drive sprocket as shown.

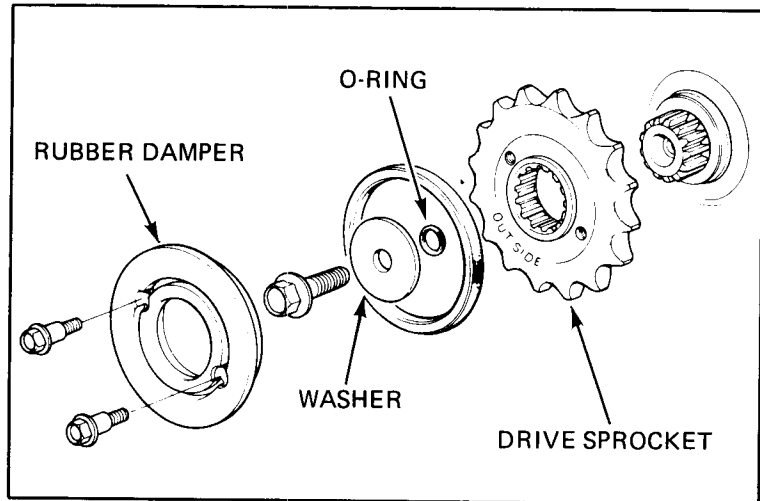

Assemble the exhaust system keeping 120 mm (4-3/4 in) between the right and left oil pan mounting holes.

Install the exhaust system loosely.

Tighten the following in the order listed:

- exhaust to cylinder head flange nuts.

**TORQUE: 30-50 N·m**  
(3.0-3.5 kg-m, 22-25 ft-lb)

- exhaust pipe-to-oil pan mounting bolts.

**TORQUE: 50-52 N·m**  
5.0-5.2 kg-m, 36-37 ft-lb)

- rear muffler mounting bolts.

**TORQUE: 35-45 N·m**  
(3.5-4.5 kg-m, 25-38 ft-lb)

- No. 2 and No. 3 exhaust pipe connecting band bolts.

**TORQUE: 20-24 N·m**  
(2.0-2.4 kg-m, 14-17 ft-lb)

Route all wires and cables properly (page 1-8).  
Fill the crankcase to the proper level with the recommended oil (page 2-2).

Perform the following inspections and adjustments:

- Throttle operation (page 3-5).
- Clutch (page 3-20).
- Drive chain (page 3-15).

