

MEMO

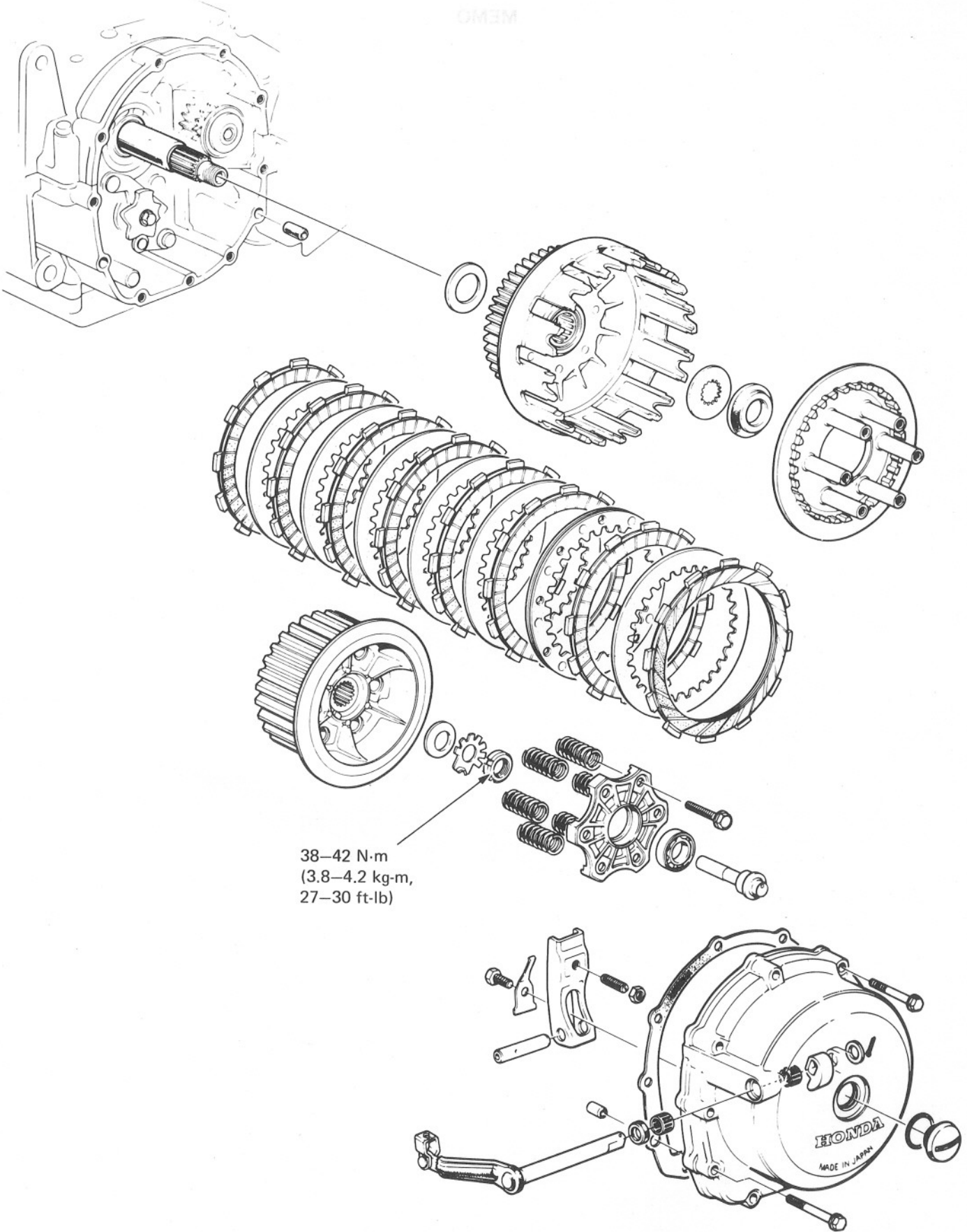



SERVICE INFORMATION	8-1	CLUTCH INSTALLATION	8-6
TROUBLESHOOTING	8-2	CLUTCH COVER INSTALLATION	8-9
CLUTCH COVER REMOVAL	8-3	STARTER CLUTCH DISASSEMBLY	8-11
CLUTCH REMOVAL	8-3	STARTER CLUTCH ASSEMBLY	8-13

SERVICE INFORMATION

GENERAL

- This section covers removal and installation of the clutch and starter clutch.
- Clutch maintenance can be done with the engine in the frame.

SPECIFICATIONS

		STANDARD	SERVICE LIMIT	
Clutch	Lever free play (at lever end)	10-20 mm (3/8-3/4 in)	—————	
	Spring free length	40.3 mm (1.59 in)	38.9 mm (1.53 in)	
	Spring preload/length	19.6-21.4 kg/27.4 mm (43.21-47.18 lbs/1.08 in)	18.1 kg/27.4 mm (39.91 lbs/1.08 in)	
	Disc thickness	A	3.72-3.88 mm (0.146-0.153 in)	3.4 mm (0.13 in)
		B	3.72-3.88 mm (0.146-0.153 in)	3.4 mm (0.13 in)
Plate warpage	—————	0.30 mm (0.012 in)		
Starter clutch	Drive gear O.D.	42.275-42.300 mm (1.6644-1.6654 in)	42.255 mm (1.6636 in)	

TORQUE VALUES

Clutch lock nut	38-42 N·m (3.8-4.2 kg-m, 27-30 ft-lb)
Primary drive gear lock bolt	80-100 N·m (8.0-10.0 kg-m, 58-72 ft-lb)
Starter clutch locking bolt	26-30 N·m (2.6-3.0 kg-m, 19-22 ft-lb)
Spark advancer bolt	33-37 N·m (3.3-3.7 kg-m, 24-27 ft-lb)

TOOLS

Special

Primary Gear Holder	07924-4250000 – Not available in U.S.A.
Clutch Center Holder	07923-3710000 or 07923-4610000
10 mm Socket Bit	07916-3710000 or Commercially available in U.S.A.

Common

Lock Nut Wrench 20 x 24 mm	07716-0020100 or 07916-3710000
Handle	07716-0020500 or Commercially available in U.S.A.



CLUTCH

TROUBLESHOOTING

Clutch

Faulty clutch operation can usually be corrected by adjusting the free play.

Clutch slips

- 1. No free play.
- 2. Discs worn.
- 3. Springs weak.

Motorcycle creeps with clutch disengaged

- 1. Too much free play.
- 2. Plates warped.

Clutch will not disengage

- 1. Too much free play.
- 2. Plates warped.

Excessive lever pressure

- 1. Clutch cable kinked, damaged or dirty.
- 2. Lifter mechanism damaged.

Clutch operation feels rough

- 1. Outer drum slots rough.



CLUTCH COVER REMOVAL

Drain the engine oil thoroughly (Page 2-2).

Disconnect the clutch cable at the lower adjuster and remove the rear brake pedal and right foot peg. Remove the muffler protector.

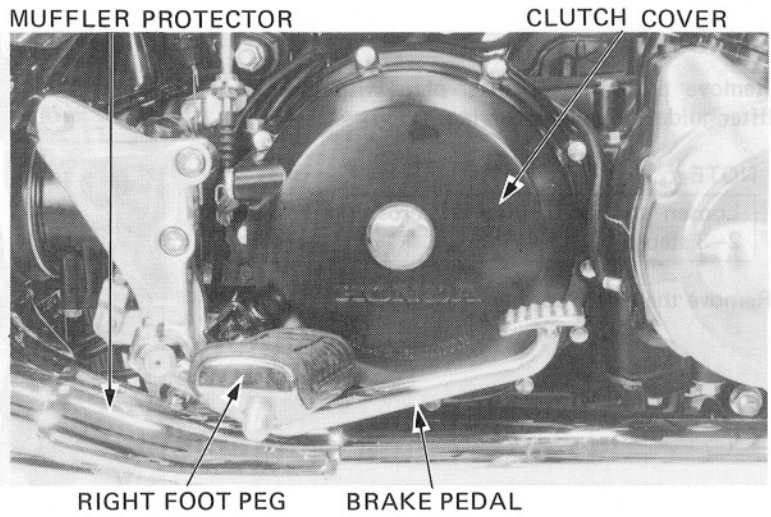

CLUTCH LIFTER REMOVAL

Remove the adjusting arm.

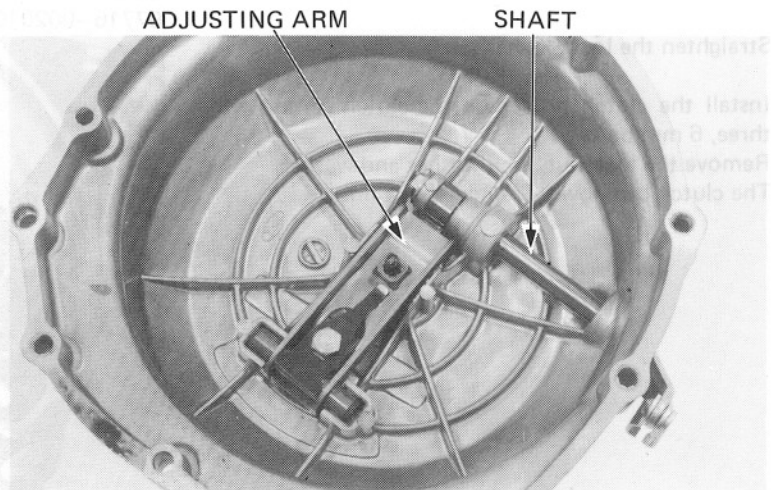

Remove the clutch lifter shaft.

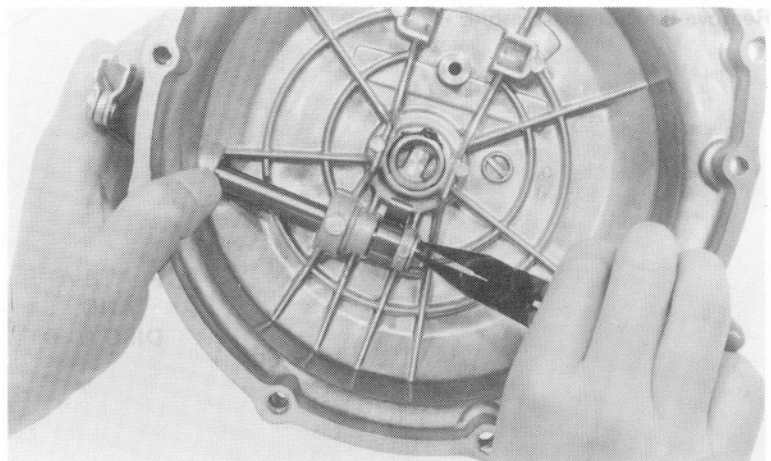

CLUTCH

REMOVAL

Remove the bolts and lifter plate with the clutch lifter guide and release bearing.

NOTE

Loosen the bolts in a crisscross pattern in 2-3 steps.

Remove the clutch springs.

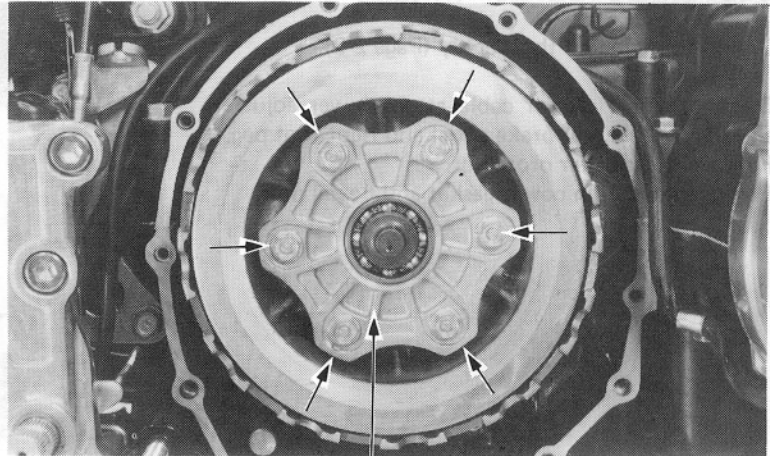

LIFTER
PLATE

LOCK NUT WRENCH, 20 x 24 mm
07716-0020100 OR 07916-3710000

EXTENSION

Straighten the lock washer tab.

Install the clutch holder on the clutch center with three, 6 mm bolts.

Remove the lock nut, lock washer and washer.
The clutch can now be removed as a unit.

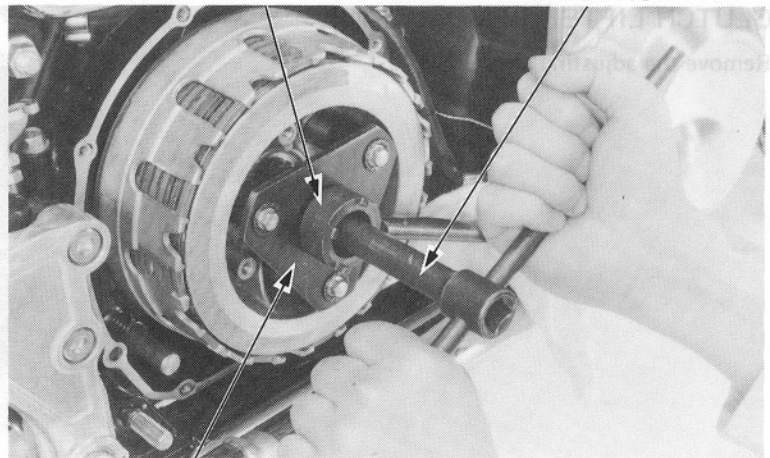

CLUTCH CENTER HOLDER
07923-3710000 OR 07923-4610000

Remove the clutch assembly.

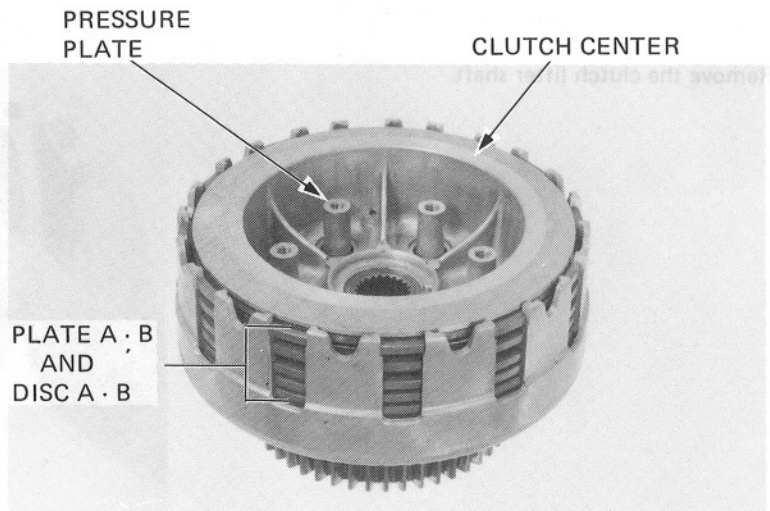

PRESSURE
PLATE

CLUTCH CENTER

PLATE A · B
AND
DISC A · B



CLUTCH SPRING INSPECTION

Measure the spring free lengths. Replace the springs if they are shorter than the service limit.

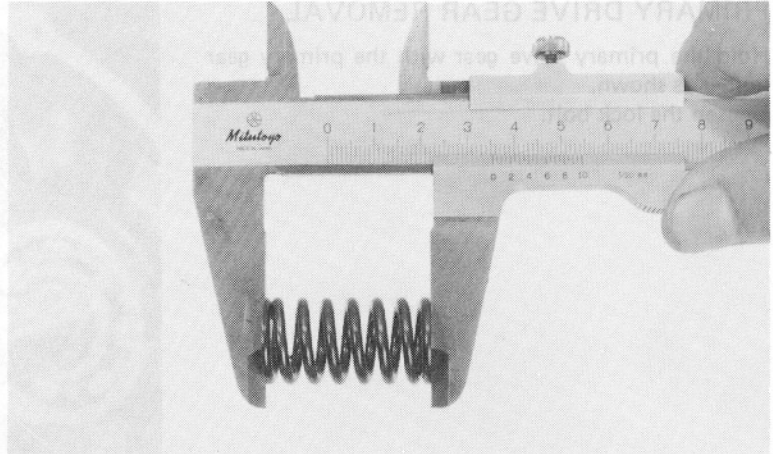

STANDARD: 40.3 mm (1.59 in)
SERVICE LIMIT: 38.9 mm (1.53 in)

CLUTCH DISC INSPECTION

Replace the clutch discs if they show signs of scoring or discoloration. Measure the disc thickness.



STANDARD: 3.72–3.88 mm
(0.146–0.153 in)
SERVICE LIMIT: 3.4 mm (0.13 in)

PLATE INSPECTION

Check for plate warpage on a surface plate, using a feeler gauge.

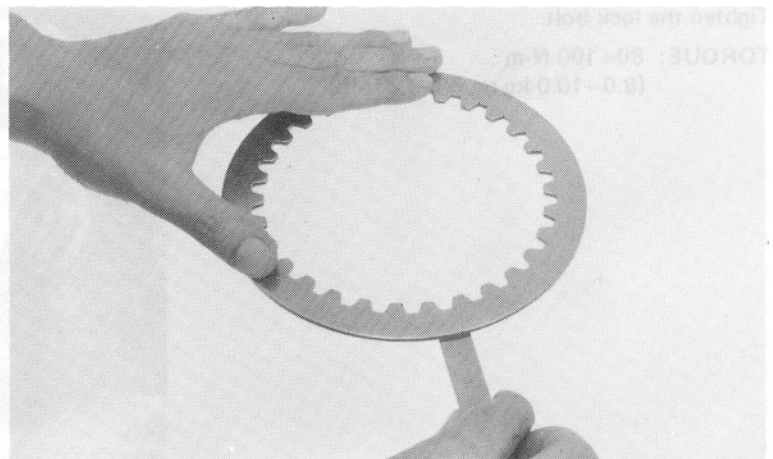

SERVICE LIMIT:
0.30 mm (0.012 in)

PRIMARY DRIVE GEAR REMOVAL

Hold the primary drive gear with the primary gear holder as shown.
Loosen the lock bolt.

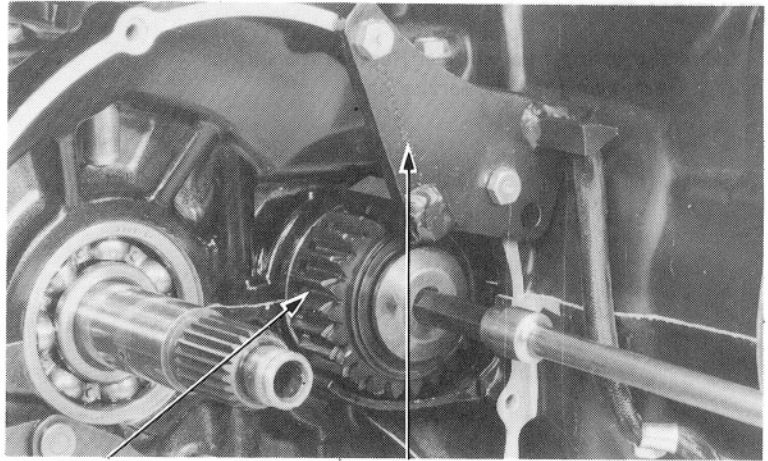

PRIMARY DRIVE GEAR

PRIMARY GEAR HOLDER
07924-4250000 (NOT AVAILABLE IN U.S.A.)

CLUTCH INSTALLATION

Install the primary drive gear with the large gear facing out.
Install the collar and lock washer as shown.

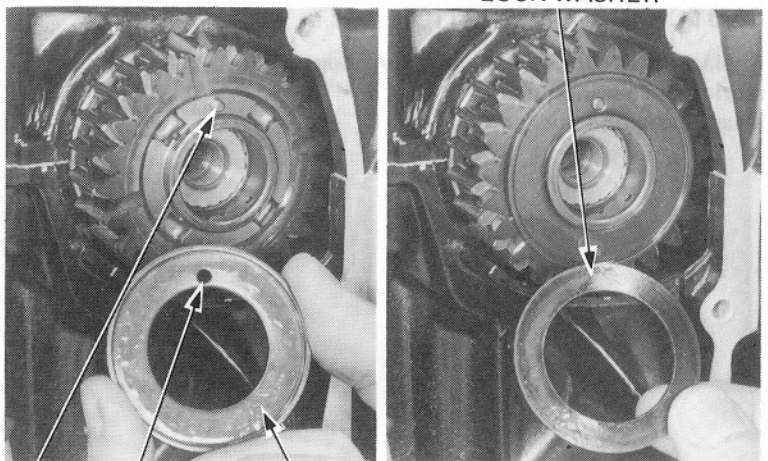

PIN HOLE COLLAR

PRIMARY GEAR HOLDER
07924-4250000
(NOT AVAILABLE IN U.S.A.)

LOCK WASHER
10 mm SOCKET BIT
07917-3710000
(COMMERCIALY AVAILABLE IN U.S.A.)

Tighten the lock bolt.

TORQUE: 80-100 N·m
(8.0-10.0 kg·m, 58-72 ft-lb)

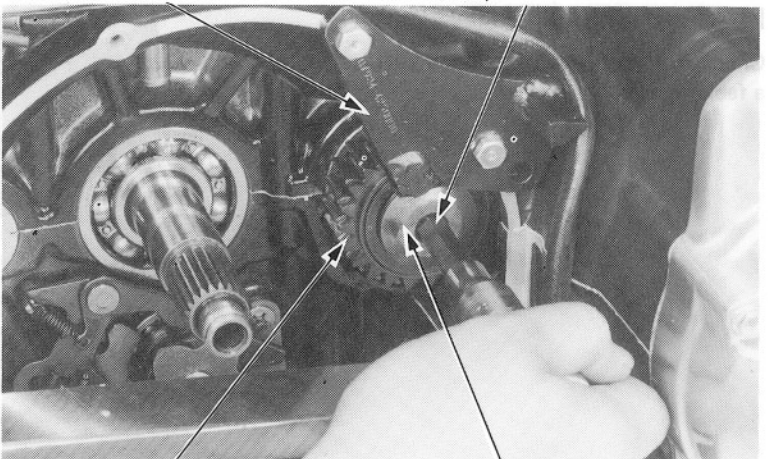

PRIMARY DRIVE GEAR

LOCK BOLT



CLUTCH OUTER NEEDLE BEARING REPLACEMENT

Remove the needle bearings as shown.

Install the needle bearing into the clutch outer with the number on the bearing facing out.



ATTACHMENT 32 x 35 mm
07746-0010100
PILOT 25 mm
07746-0030200

Install the washer and clutch outer.

Install the washer and collar.

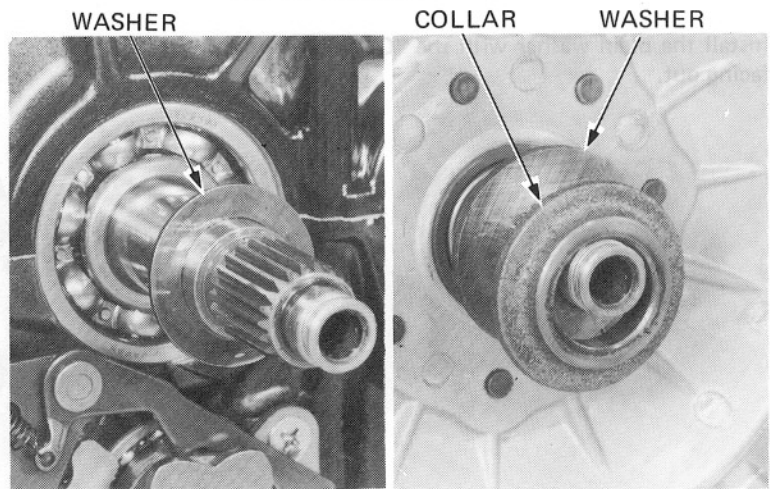

Assemble the clutch discs A and B, plate A and B, clutch pressure plate, and clutch center.

NOTE

- Before installing the clutch, coat the discs and plates with engine oil.
- Install disc B with the grooves facing in the direction shown.

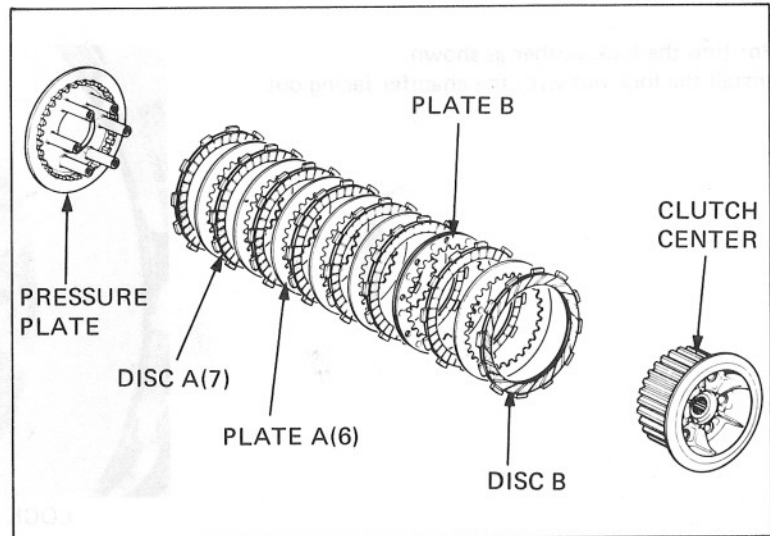

CLUTCH

Install the clutch assembly, by rotating the clutch center.

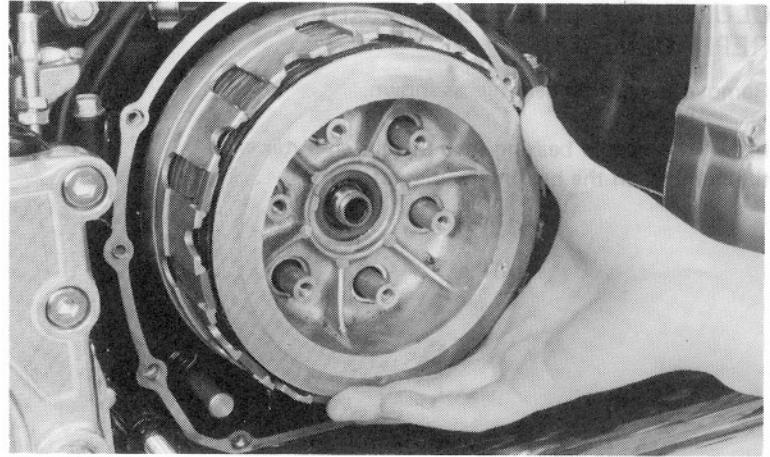

Install the plain washer with the "OUTSIDE" mark facing out.

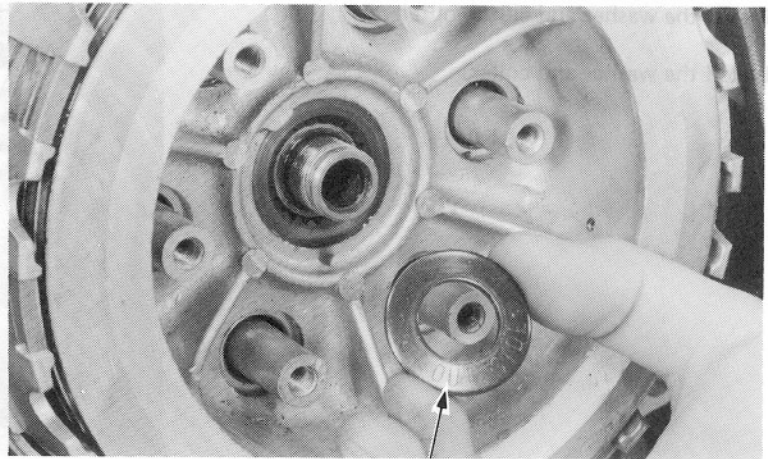

WASHER

Position the lock washer as shown.
Install the lock nut with the chamfer facing out.

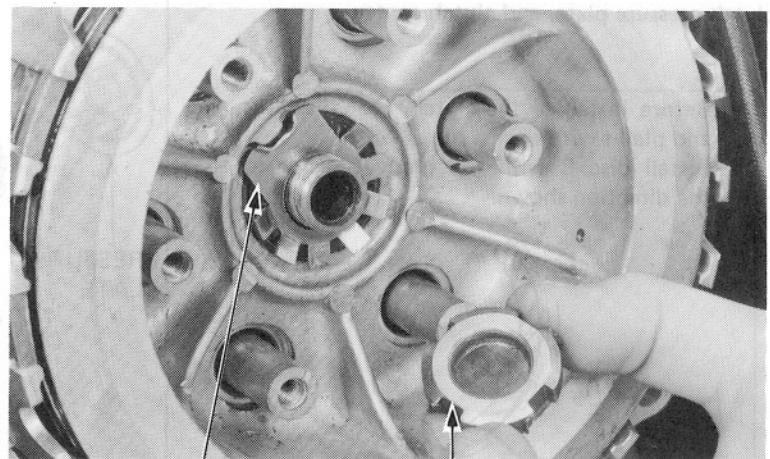

LOCK WASHER

LOCK NUT



LOCK NUT WRENCH, 20 x 24 mm
07716-0020100 OR 07916-3710000

Install the clutch holder on the clutch center with three, 6 mm bolts.

Tighten the lock nut.

TORQUE: 38-42 N·m (3.8-4.2 kg·m, 27-30 ft·lb)

Bend the lock washer tab as shown.

Install the clutch springs, lifter plate, bearing and lifter guide. Tighten the bolts.

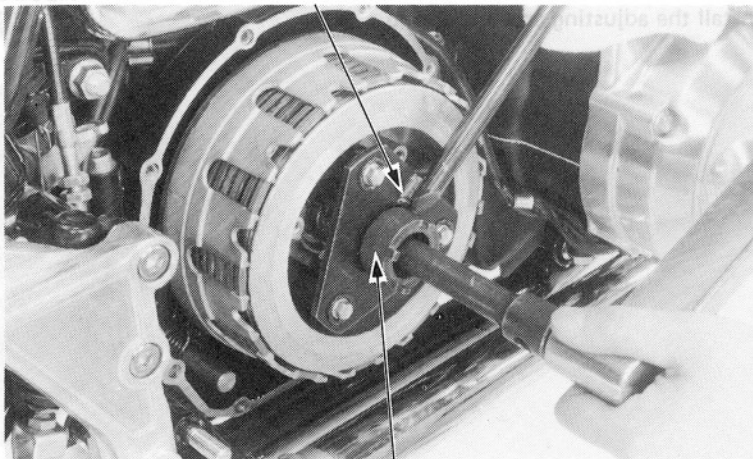

CLUTCH CENTER HOLDER
07923-3710000 OR 07923-4610000

Install the clutch spring, lifter plate, lifter guide and release bearing. Tighten the bolts.

NOTE

Tighten the bolts in a crisscross pattern in 2-3 steps.

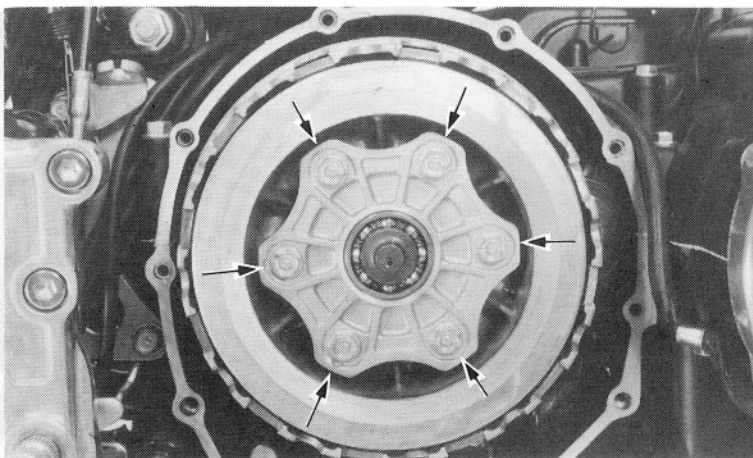

CLUTCH COVER INSTALLATION

Install the clutch lifter cam and shaft washer. Insert the cotter pin and spread the ends.

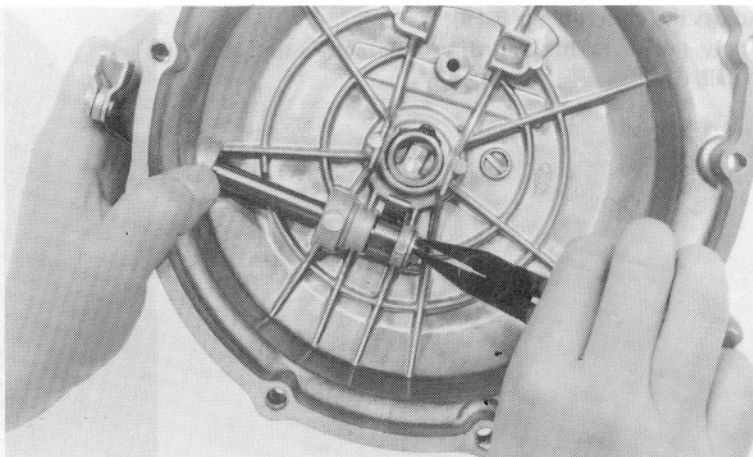

CLUTCH

Install the adjusting arm and spring.

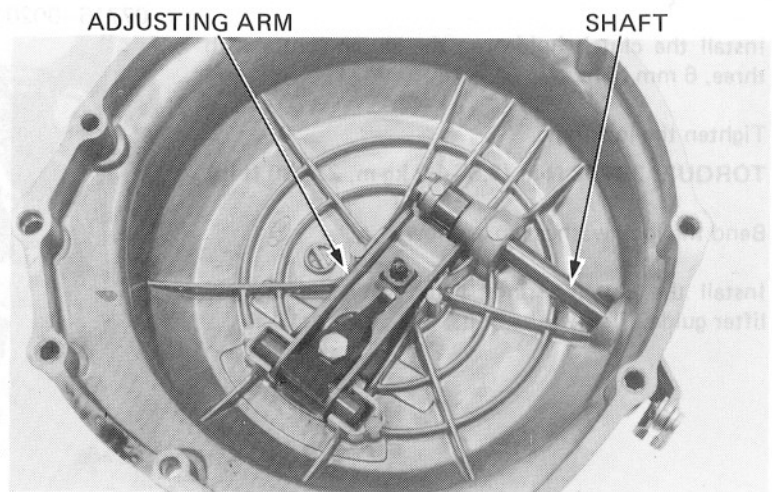

Install the dowel pins and gasket, and then install the cover.

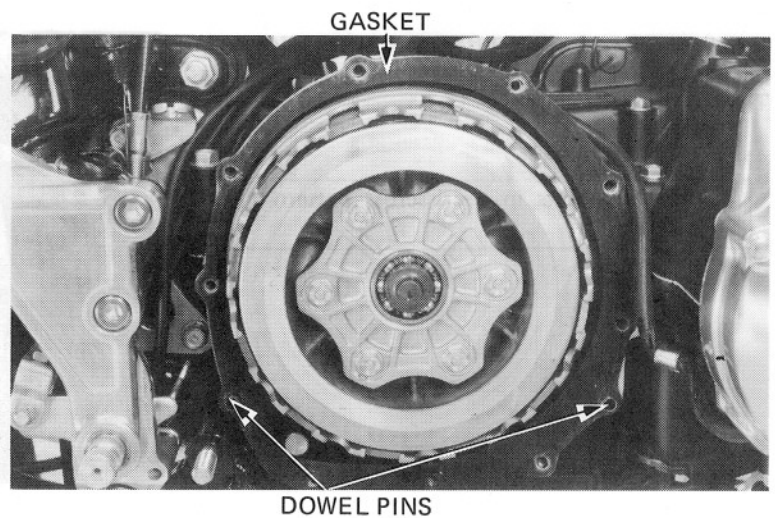

Adjust the clutch (Page 3-19).
Apply grease to the adjusting hole cap O-ring and install.

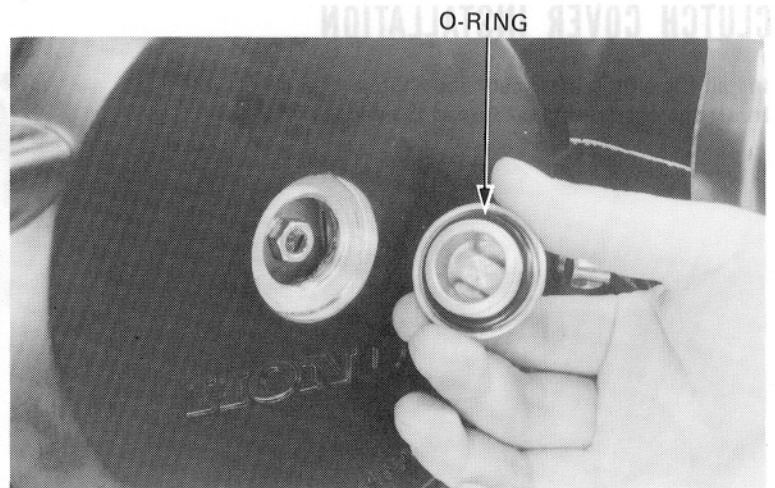



STARTER CLUTCH DISASSEMBLY

Remove the left crankcase cover with the pulse generator assembly.

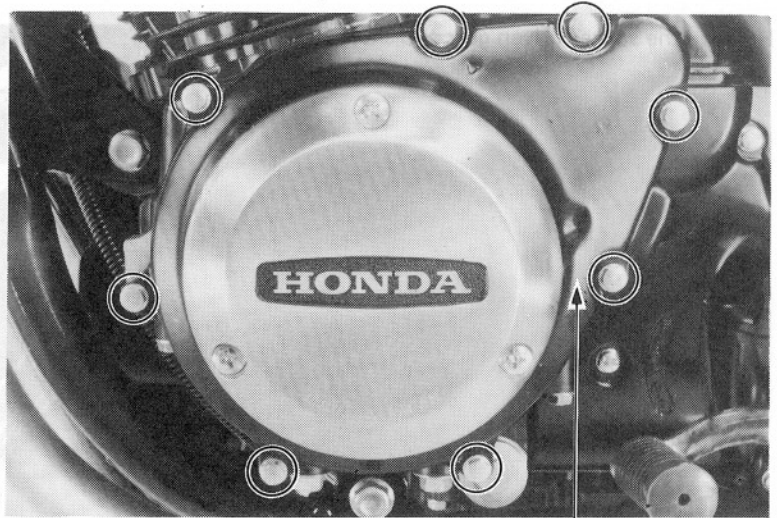
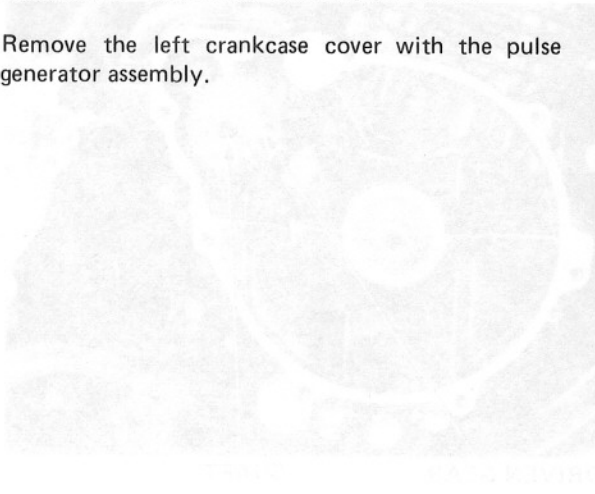

LEFT CRANKCASE COVER

Remove the spark advancer unit.

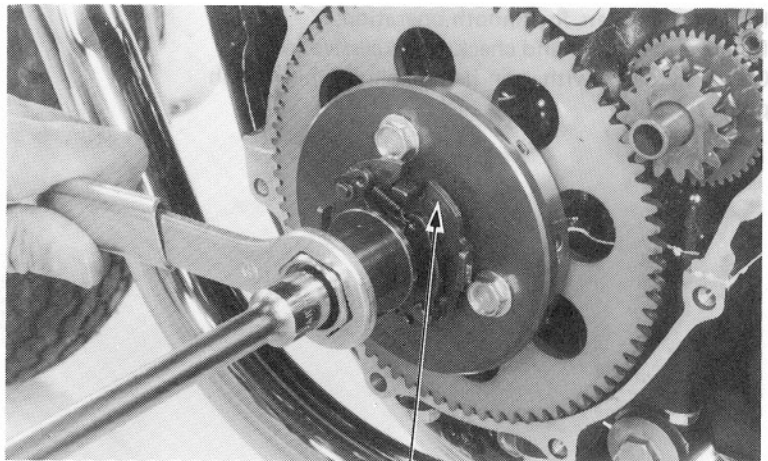
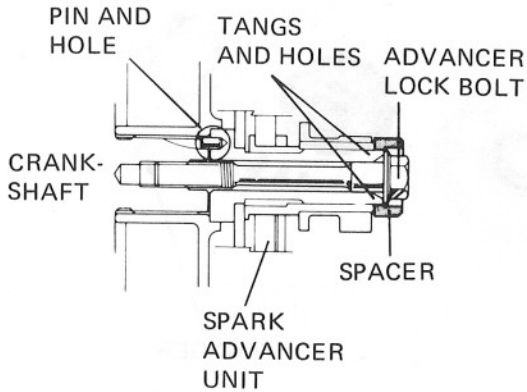

SPARK ADVANCER

Remove the starter clutch assembly.

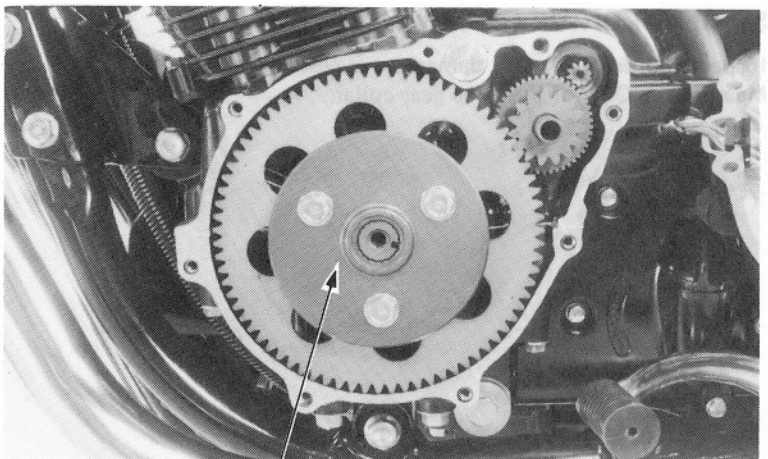

STARTER CLUTCH

CLUTCH

Remove the starter driven gear and shaft.

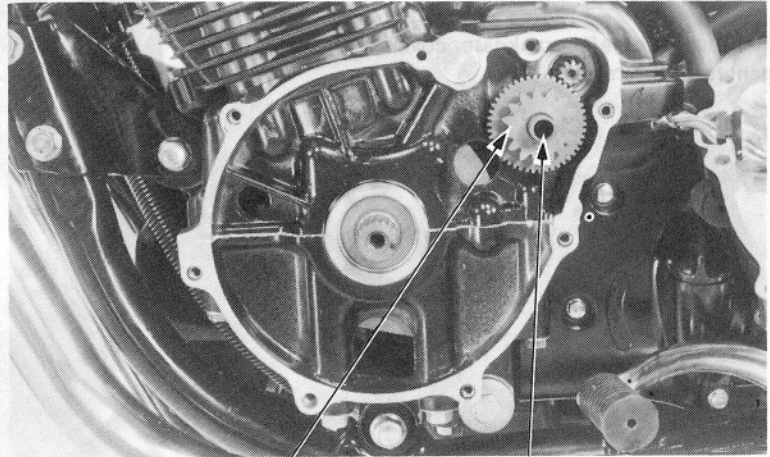

DRIVEN GEAR

SHAFT

Inspect the rollers for smooth operation. Remove the rollers and check for excessive wear. Clean all parts with non-flammable or high flash point solvent.

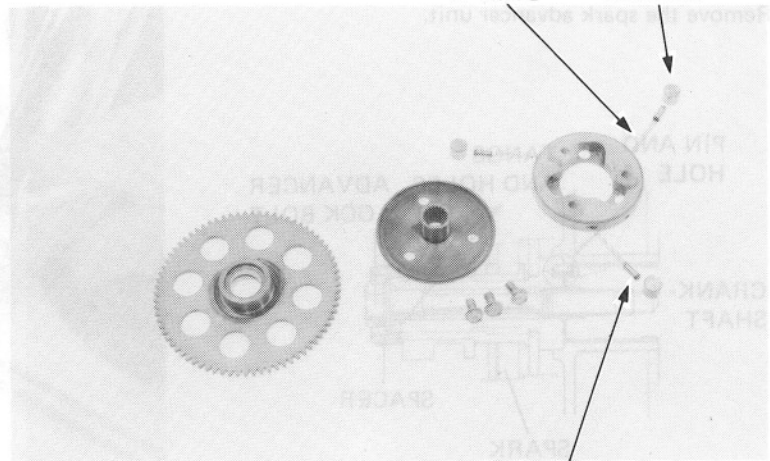

SPRING

ROLLER

PLUNGER

STANDARD: 42.275–42.300 mm (1.6644–1.6654 in)

SERVICE LIMIT: 42.255 mm (1.6636 in)

STARTER DRIVE GEAR INSPECTION

Inspect the drive gear for damage or excessive wear. Measure the O.D. of the drive gear collar.

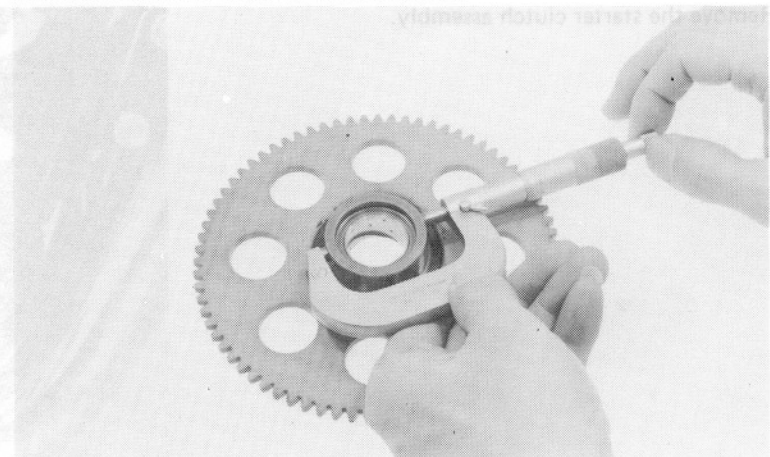



STARTER CLUTCH ASSEMBLY

Install the springs, plungers and rollers.
Tighten the locking bolts to the specified torque.

TORQUE: 26–30 N·m (2.6–3.0 kg·m, 19–22 ft·lb)

NOTE

Apply a locking agent to the locking bolt's threads.

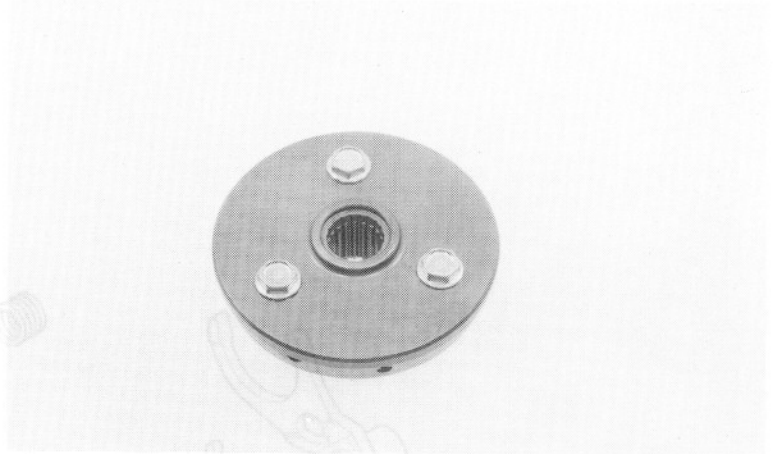

Install the advancer assembly. Align the pin on the spark advancer unit with the slot on the crankshaft.

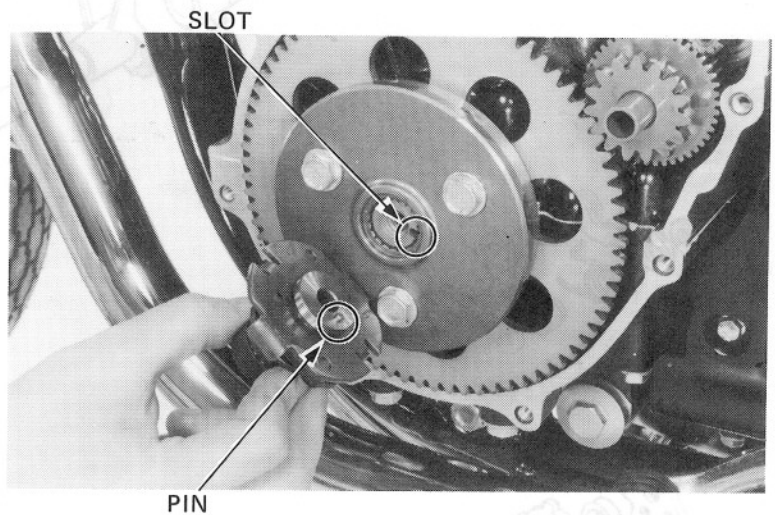

Install the spacer aligning the tangs with the holes, and tighten the advancer lock bolt to the specified torque.

TORQUE: 33–37 N·m (3.3–3.7 kg·m, 24–27 ft·lb)

Install the left crankcase cover.

