

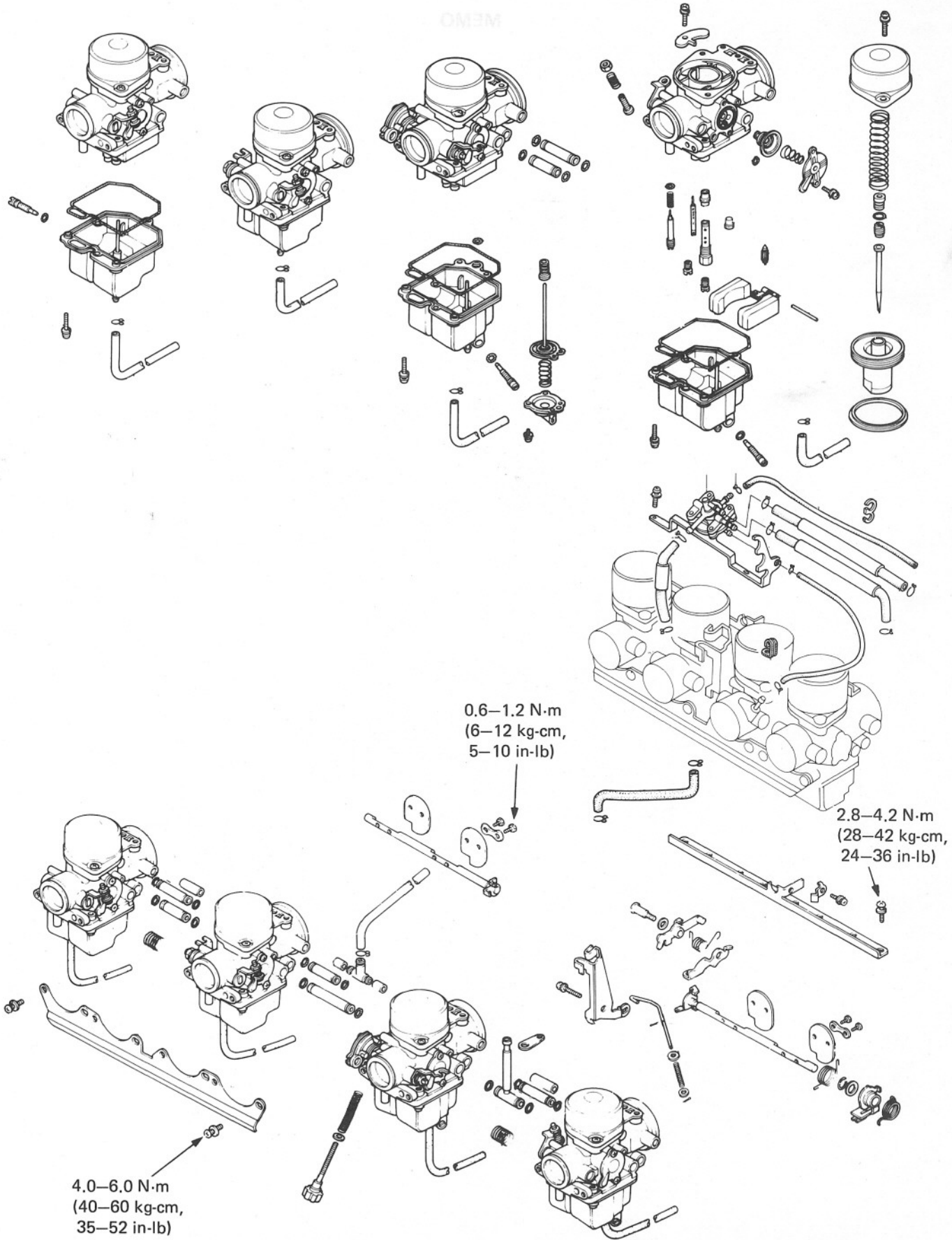

**FUEL SYSTEM**

MEMO





SERVICE INFORMATION	4-1	CARBURETOR SEPARATION	4-9
TROUBLESHOOTING	4-2	LINKAGE	4-12
FUEL LINE DIAPHRAGM	4-3	CARBURETOR ASSEMBLY	4-13
CARBURETOR TUBE ROUTING	4-3	FAST IDLE ADJUSTMENT	4-17
CARBURETOR REMOVAL	4-4	ACCELERATOR PUMP ADJUSTMENT	4-17
VACUUM CYLINDER DISASSEMBLY	4-4	CARBURETOR INSTALLATION	4-17
PILOT SCREW	4-5	PILOT SCREW ADJUSTMENT	4-18
FLOAT AND JETS	4-6	LIMITER CAP INSTALLATION	4-19
AIR-CUTOFF VALVE DISASSEMBLY	4-7	HIGH ALTITUDE ADJUSTMENT	4-19
ACCELERATOR PUMP DISASSEMBLY	4-8	FUEL TANK	4-20
COMPONENT ASSEMBLY	4-8	AIR CLEANER	4-21
FLOAT LEVEL	4-9		

## SERVICE INFORMATION

### GENERAL

- The carburetors are equipped with a fuel line diaphragm. After carburetor overhaul, it is necessary to crank the engine for 2-3 seconds, three times with the throttle fully closed to fill the float chambers.
- The pilot screws are factory pre-set and should not be removed unless the carburetor is overhauled.
- Use caution when working with gasoline. Always work in a well-ventilated area and away from sparks or open flames.
- When disassembling fuel system parts, note the locations of the O-rings. Replace them with new ones on reassembly.
- The float bowls have drain plugs that can be loosened to drain residual gasoline.

### SPECIFICATIONS

Venturi dia.	32 mm (1.3 in)
Identification No.	VB55A
Float level	15.5 mm (0.61 in)
Main jet	Pri. : 68      2nd. : 110
Slow jet	35
Idle speed	1,000 ± 100 rpm
Throttle grip free play	2-6 mm (1/8-1/4 in)
Fast idle	1,000-2,500 rpm (after break-in)
Pilot screw initial opening	See page 4-17

### TORQUE VALUES

Front bracket	4-6 N·m (40-60 kg-cm, 35-52 in-lb)
Rear bracket	2.8-4.2 N·m (28-42 kg-cm, 24-36 in-lb)
Choke valve	0.6-1.2 N·m (6-12 kg-cm, 5-10 in-lb)

### TOOLS

Common	
Float gauge	07401-0010000
Special	
Carburetor Throttle Wrench	07908-4220100
Carburetor Pilot Screw Wrench	07908-4220200

## TROUBLESHOOTING

### Fuel not reaching carburetors

1. Fuel line diaphragm vent tube clogged.
2. Fuel line diaphragm vacuum tube clogged.
3. Clogged fuel line diaphragm.
4. Clogged fuel line diaphragm check valve.

### Engine cranks but won't start

1. No fuel in tank.
2. No fuel to carburetor.
3. Engine flooded with fuel.
4. No spark at plug (ignition malfunction).
5. Air cleaner clogged.
6. Intake air leak.
7. Improper choke operation.
8. Improper throttle operation.

### Hard starting or stalling after starting

1. Improper choke operation.
2. Ignition malfunction.
3. Fast idle speed incorrect.
4. Carburetor malfunction.
5. Fuel contaminated.
6. Intake air leak.
7. Idle speed incorrect.

### Rough idle

1. Ignition malfunction.
2. Idle speed incorrect.
3. Incorrect carburetor synchronization.
4. Carburetor malfunction.
5. Fuel contaminated.

### Misfiring during acceleration

1. Ignition malfunction.
2. Faulty air-cutoff valve.

### Backfiring

1. Ignition malfunction.
2. Carburetor malfunction.
3. Faulty air-cutoff valve.

### Poor performance (driveability) and poor fuel economy

1. Fuel system clogged.
2. Ignition malfunction.

### Lean mixture

1. Clogged fuel jets.
2. Piston stuck closed.
3. Faulty float valve.
4. Float level low.
5. Fuel cap vent blocked.
6. Fuel strainer screen clogged.
7. Restricted fuel line.
8. Air vent tube clogged.
9. Intake air leak.

### Rich mixture

1. Clogged air jets.
2. Faulty float valve.
3. Float valve too high.
4. Choke stuck closed.
5. Air-cutoff valve sticking closed.
6. Dirty air cleaner.

Adjustment	Specification
Fast idle	1,000-2,500 rpm (after break-in) See page 4-11
Throttle stop (see page 4-11)	2-6 mm (7/8-1/4 in)
Idle speed	1,000 ± 100 rpm
Slow-jet	38
Main jet	81 ± 2nd : 110
Float level	15.5 mm (0.61 in)
Identification No.	V855A
Venturi dia.	32 mm (1.3 in)



## FUEL LINE DIAPHRAGM

### REMOVAL

Turn the fuel valve off. Remove the seat and fuel tank.

Disconnect the fuel lines, vacuum tube and air vent tube.

Unscrew the screws attaching the fuel line diaphragm to the carburetors. Remove the fuel line diaphragm.

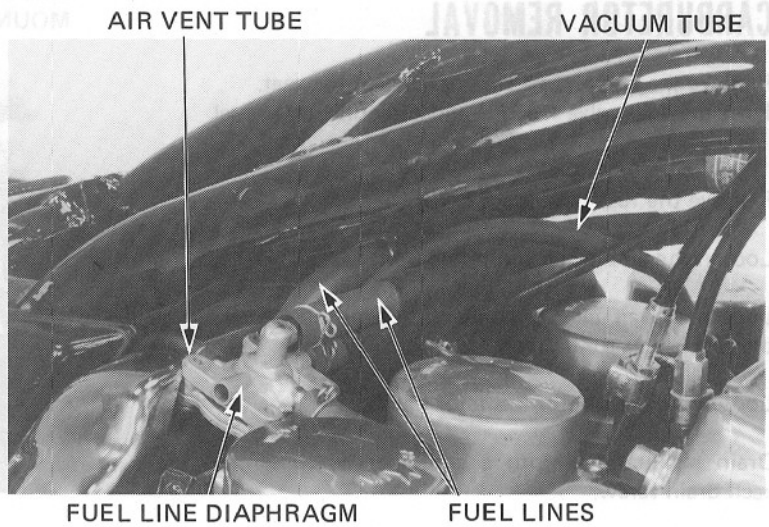

### INSPECTION

Remove the fuel line diaphragm (see above).

Disconnect the inlet fuel line from the diaphragm, and connect a longer tube to the fuel tank.

Place a suitable drainage container under the outlet fuel tube.

Turn the fuel valve on. Fuel should not flow from the outlet line.

Connect a vacuum gauge to the diaphragm vacuum outlet. Fuel should flow out from the outlet tubes when 10–20 mm Hg (0.4–0.8 in Hg) of vacuum is applied.

If the flow is restricted, replace the fuel line diaphragm.

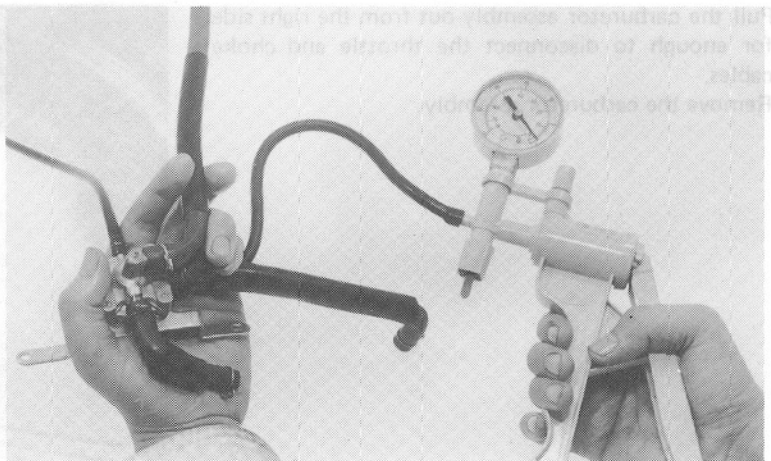

Installation of the fuel line diaphragm is the reverse of removal.

### NOTE

Check that air or gasoline is not leaking past the fuel line joints or connections.

## CARBURETOR TUBE ROUTING

Route the carburetor tubes and lines as shown.

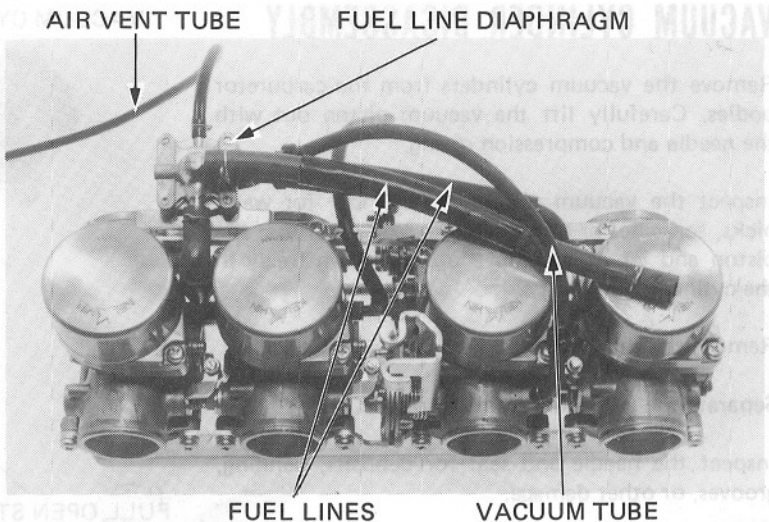



**FUEL SYSTEM**

**CARBURETOR REMOVAL**

Remove the both frame side covers and the seat.  
Turn the fuel valve "OFF" and disconnect the fuel line.

Remove the fuel tank (page 4-19).

Loosen the air cleaner mounting bolt.

Loosen the air cleaner connecting bands and move the air cleaner to the rear.

Loosen the carburetor insulator bands.

Drain residual fuel into a container by loosening each drain screw.

AIR CLEANER MOUNTING BOLT

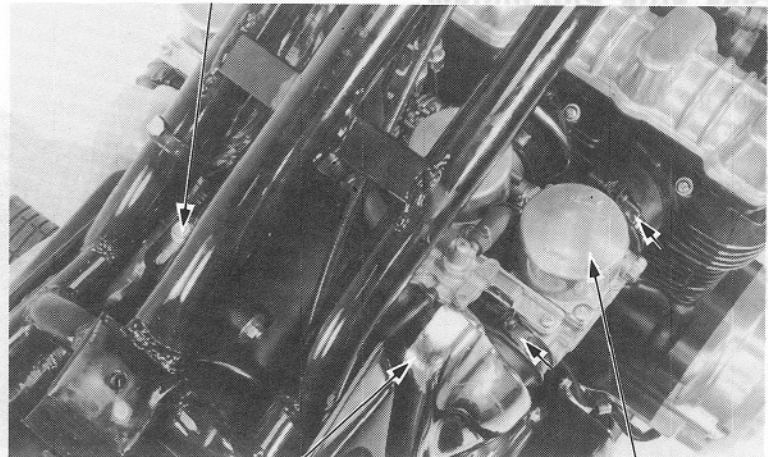

AIR CLEANER

CARBURETOR

Pull the carburetor assembly out from the right side for enough to disconnect the throttle and choke cables.

Remove the carburetor assembly.

CHOKE CABLE

THROTTLE CABLES

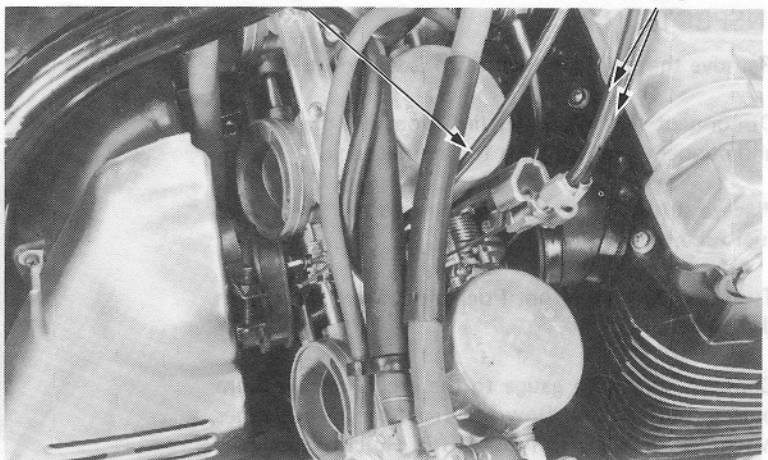

**VACUUM CYLINDER DISASSEMBLY**

Remove the vacuum cylinders from the carburetor bodies. Carefully lift the vacuum piston out with the needle and compression spring.

Inspect the vacuum piston and cylinder for wear, nicks, scratches or other damage. Make sure that the piston and jet needle move up and down freely in the cylinder.

Remove the full open stopper and needle set screw.

Separate the jet needle from the piston.

Inspect the needle and seat for deposits, bending, grooves, or other damage.

VACUUM CYLINDER    COMPRESSION SPRING    JET NEEDLE

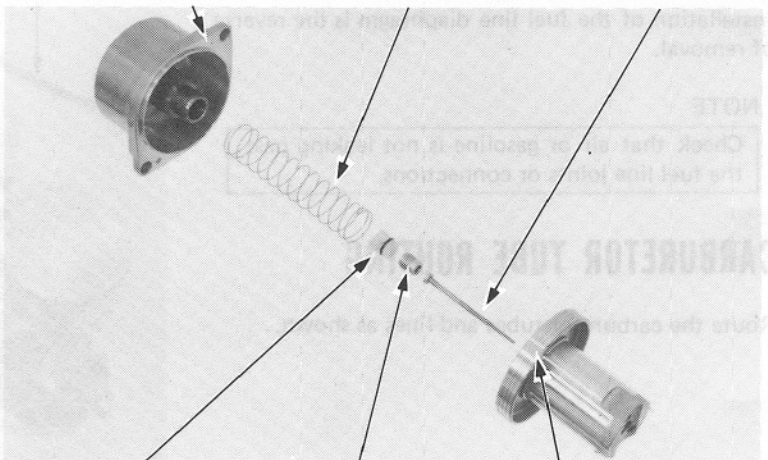

FULL OPEN STOPPER

NEEDLE SET SCREW

VACUUM PISTON SCREW



Carefully lift the seal ring off the carburetor body.

Remove the air jet cover.

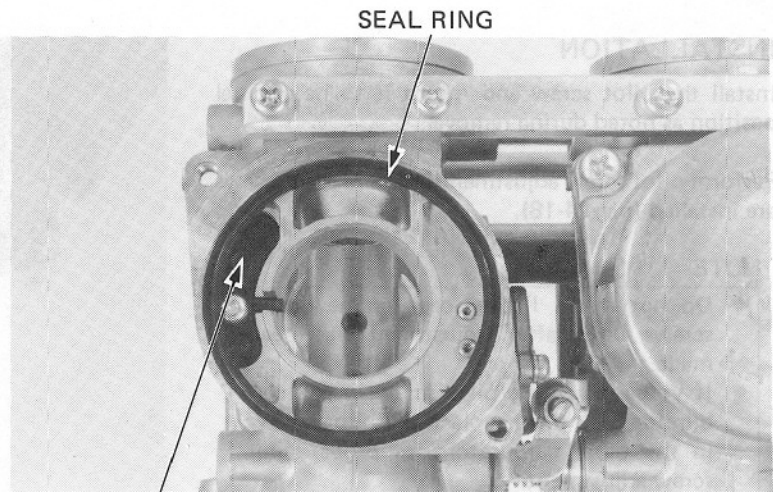

Blow open the primary main air jet, secondary main air jet and slow air jets with compressed air.

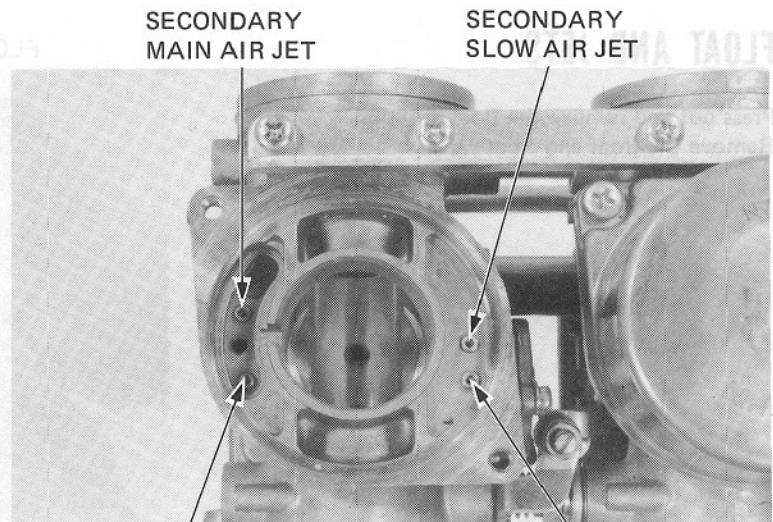

## PILOT SCREW

### REMOVAL

#### NOTE

The pilot screws are factory pre-set and should not be removed unless the carburetor is overhauled.

Remove the float chambers (U.S.A. only).

Turn each pilot screw in and carefully count the number of turns before it seats lightly. Make a note of this to use as a reference when reinstalling the pilot screws.

#### CAUTION

*Damage to the pilot screw seat will occur if the pilot screw is tightened against the seat.*

Remove each pilot screw.

Inspect the pilot screws and replace them all if any are worn or damaged.

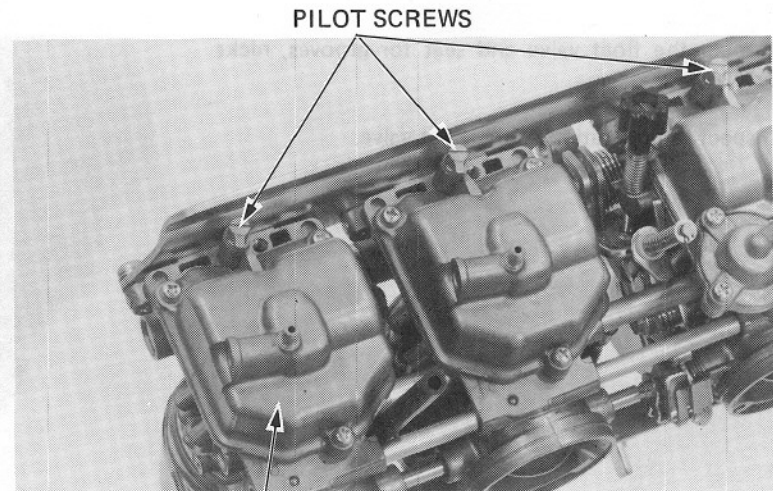



## FUEL SYSTEM

### INSTALLATION

Install the pilot screw and return it to its original position as noted during removal.

Perform pilot screw adjustment if a new pilot screws are installed (page 4-18).

#### NOTE

- Do not install limiter caps on new pilot screws until after adjustment has been made.
- If you replace the pilot screw in one carburetor, you must replace the pilot screws in the other carburetors for proper pilot screw adjustment.

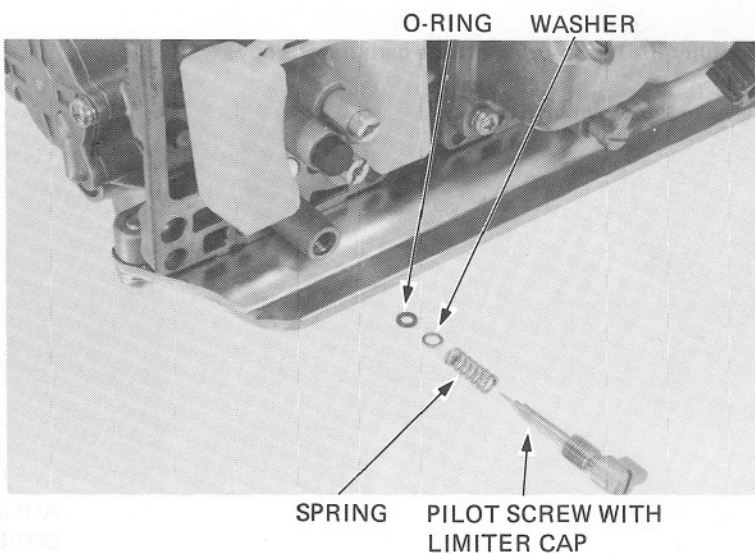

### FLOAT AND JETS

Press out and remove the float arm pin.  
Remove the float and float valve.

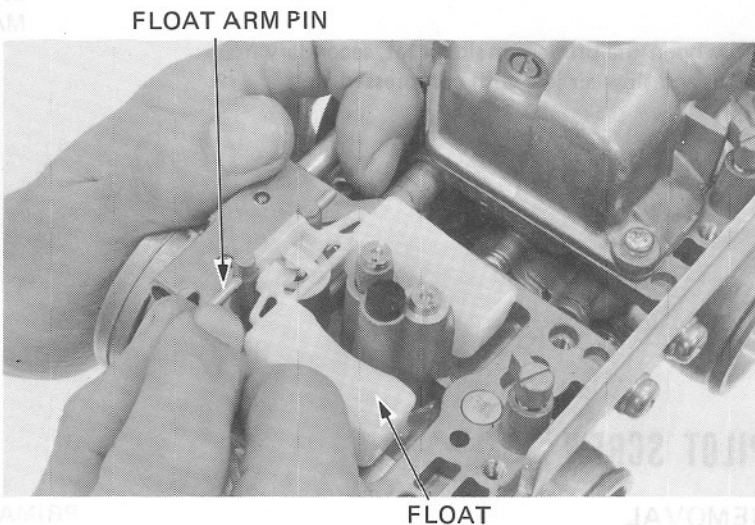

Inspect the float valve and seat for grooves, nicks or deposits.

Inspect the operation of the float valve.

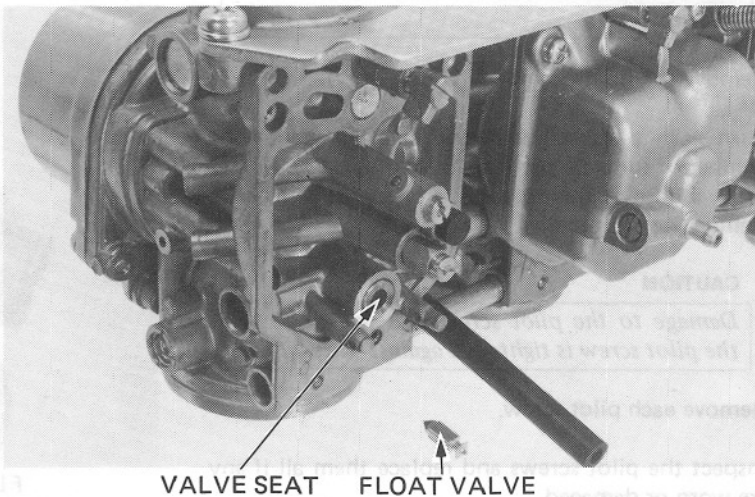



Remove the secondary main jet and primary main jet.

Remove the slow jet plug and slow jet.

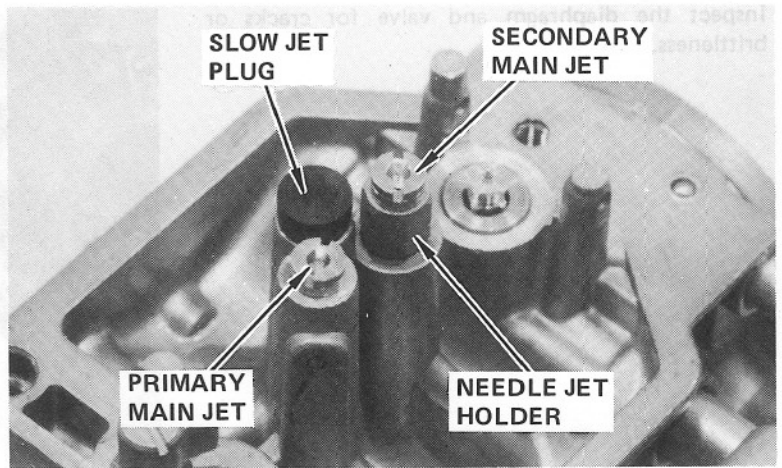

Remove the primary nozzle and needle jet holder.

Tilt the carburetor to remove the needle jet.  
Blow all jets and body passages with compressed air.

### NOTE

If the needle jet is difficult to remove, carefully press the needle jet from the cylinder side with a non-metallic object to prevent damage to the needle jet.

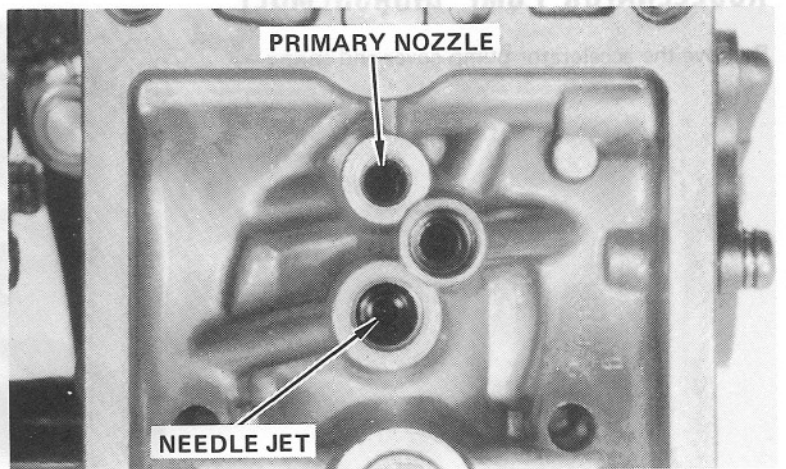

## AIR-CUTOFF VALVE DISASSEMBLY

Remove the air-cutoff valve cover and spring.  
Remove the diaphragm and O-ring.

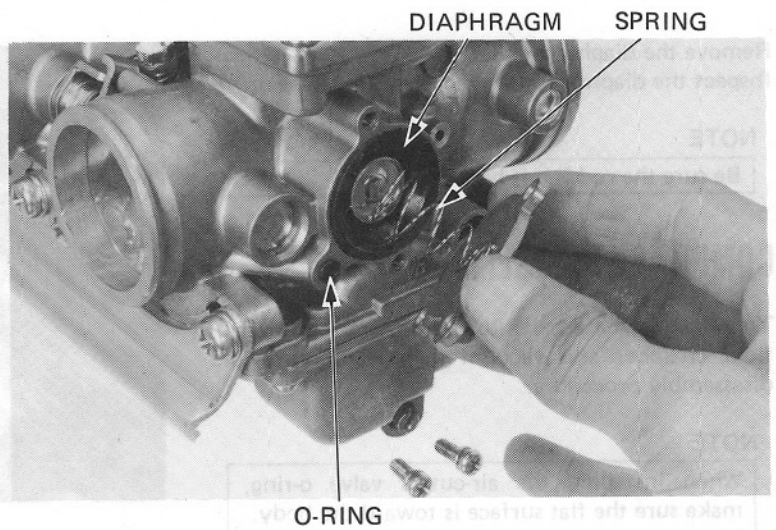



**FUEL SYSTEM**

Inspect the diaphragm and valve for cracks or brittleness.

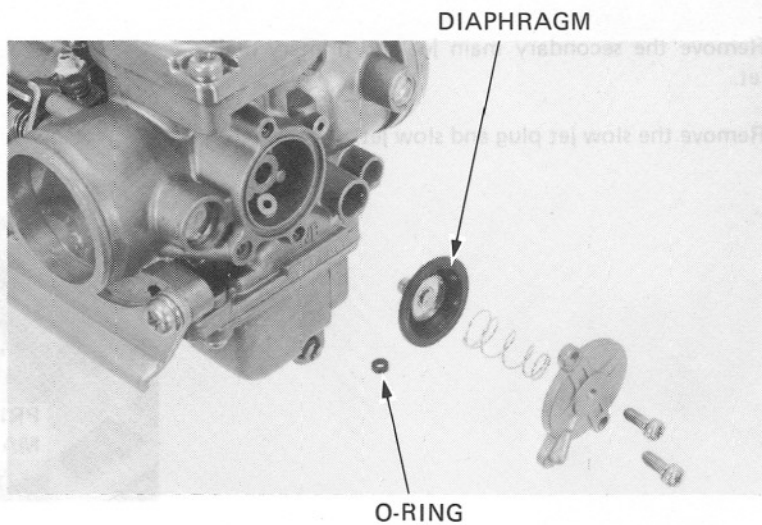

**ACCELERATOR PUMP DISASSEMBLY**

Remove the accelerator pump cover and spring.

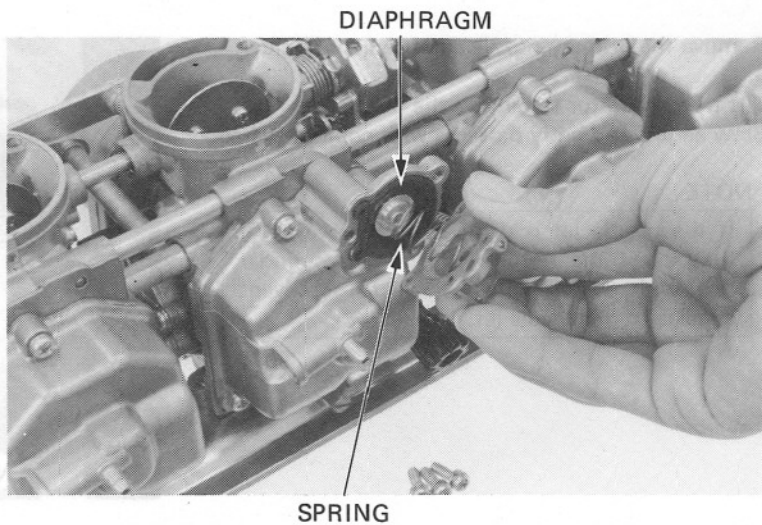
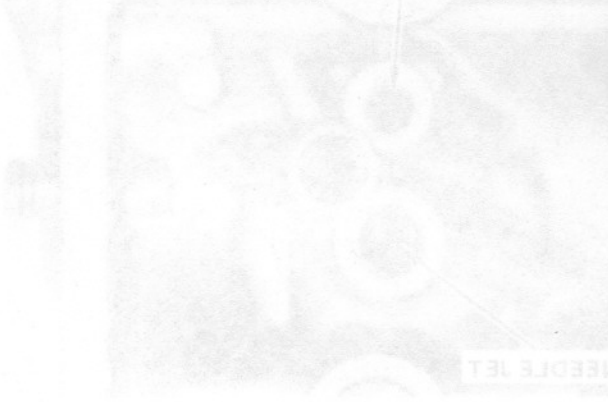

Remove the diaphragm.  
Inspect the diaphragm for cracks and brittleness.

**NOTE**

Be sure the rod is not bent.

**COMPONENT ASSEMBLY**

To assemble the accelerator pump, air-cutoff valve, float chamber and vacuum cylinder, reverse the disassembly procedure.

**NOTE**

When installing the air-cutoff valve o-ring, make sure the flat surface is toward the body.

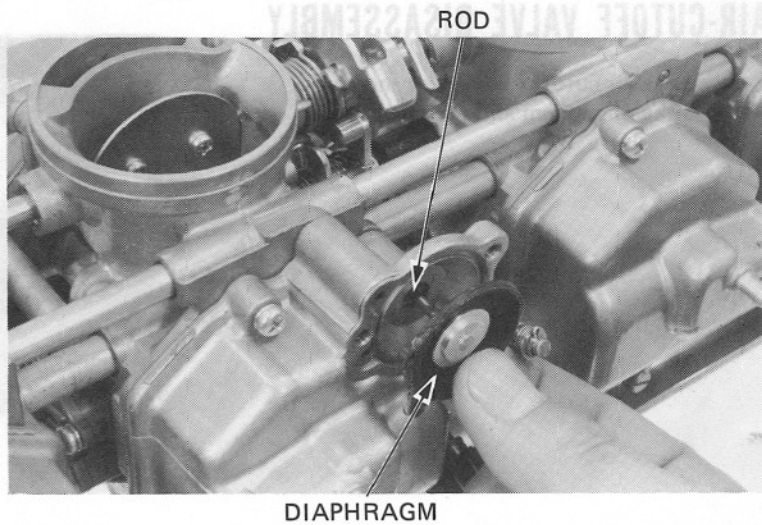



### FLOAT LEVEL

Remove the float chamber.

Measure the float level with the float tip just contacting the float valve and the carburetor inclined  $15^{\circ}\sim 45^{\circ}$  from vertical.

**FLOAT LEVEL:  $15.5 \pm 1$  mm ( $0.61 \pm 0.04$  in)**

Replace the float, if the float level is not within the specification.

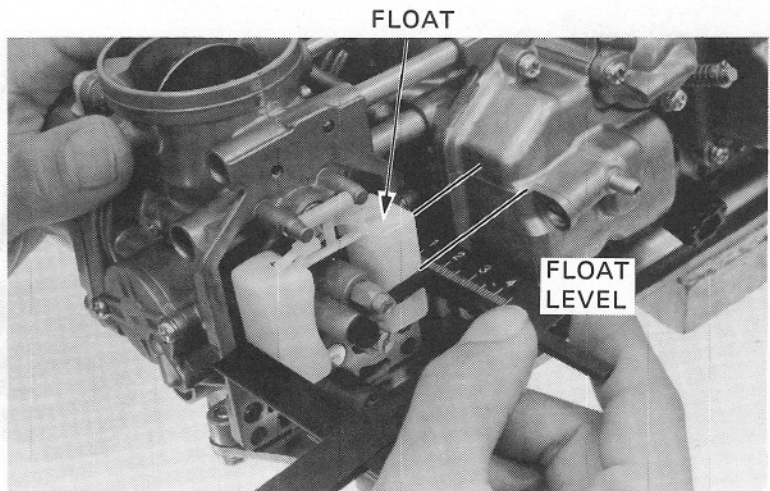

### CARBURETOR SEPARATION

Unhook the choke relief spring from the choke shaft arm of the No. 2 and No. 3 carburetors.

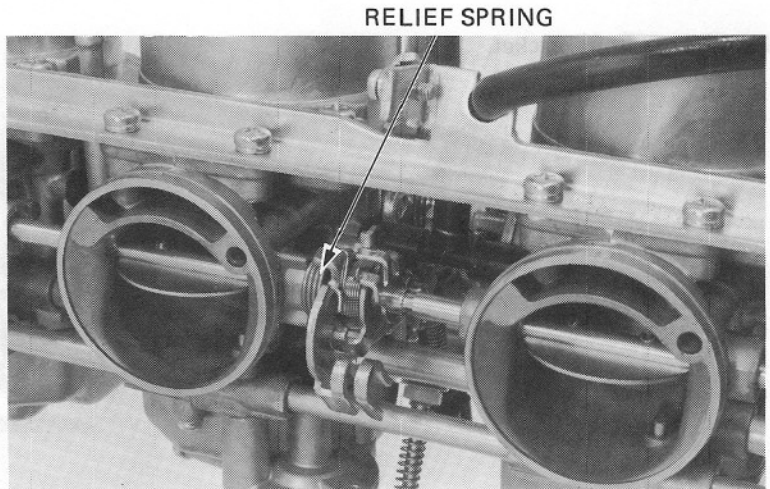

Loosen the synchronization adjusting screw lock nuts and adjusting screws until there is no tension.

#### NOTE

Turn the synchronization screws in until they seat and note the number of turns to ensure original positioning.

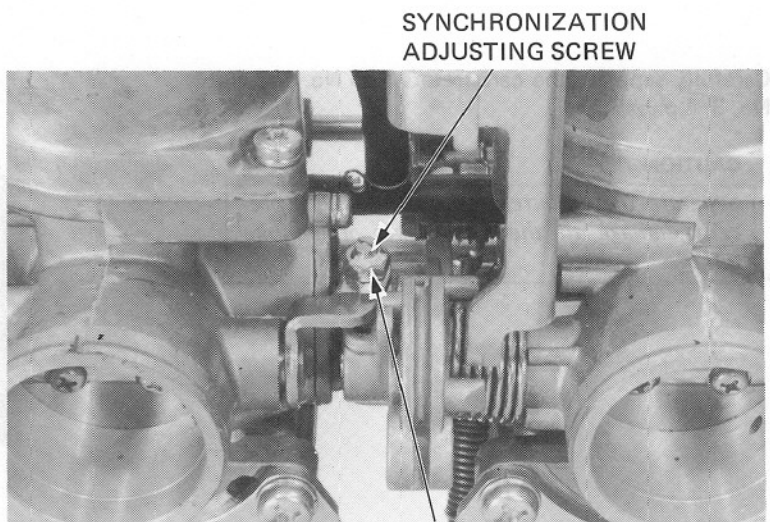



**FUEL SYSTEM**

Remove the rear bracket.

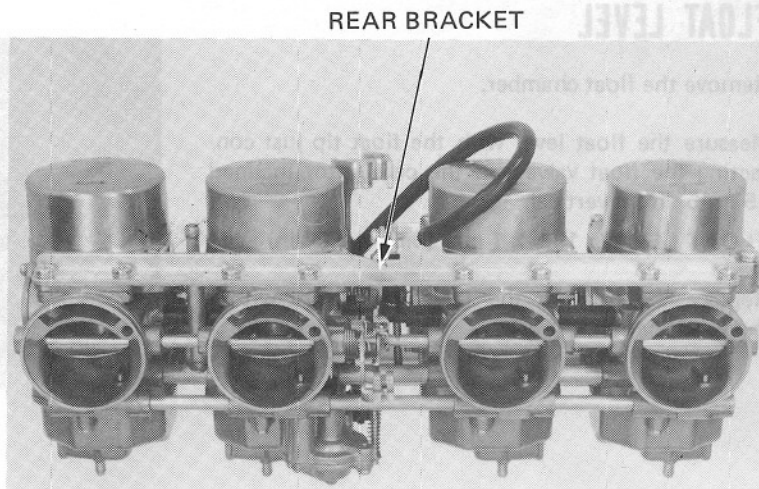
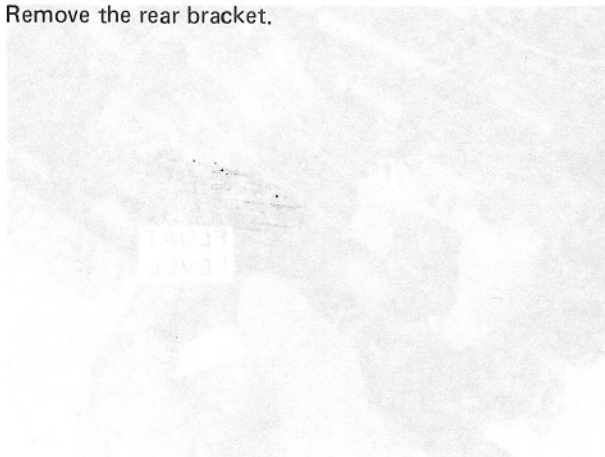

Remove the front bracket.

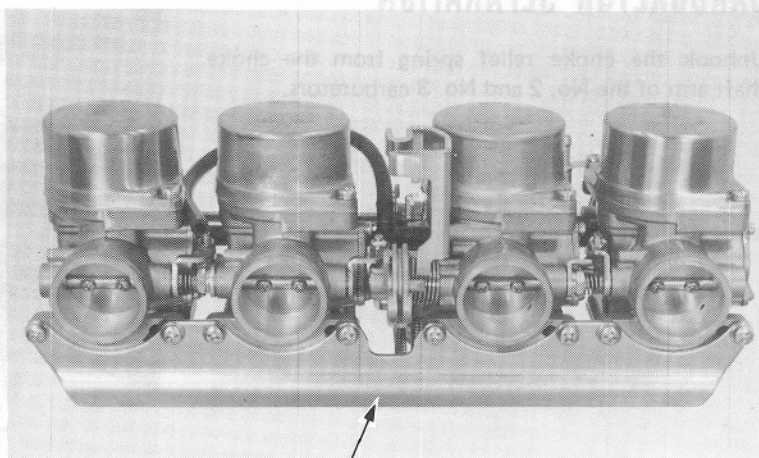
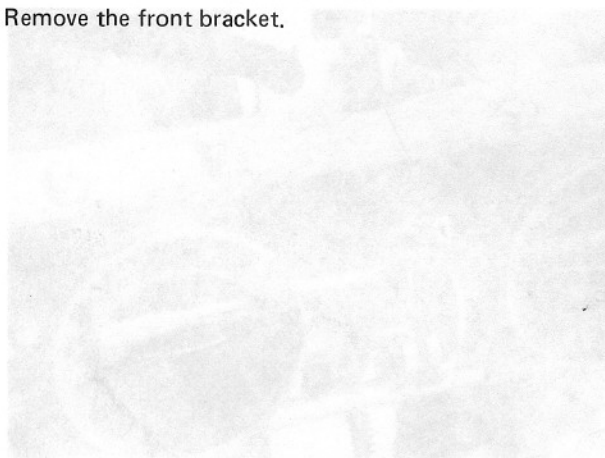

Carefully separate the carburetors into No. 1, 2 and No. 3, 4 pairs.

**CAUTION**

*Separate the carburetors horizontally to prevent damage to the joint pipes and choke linkage.*

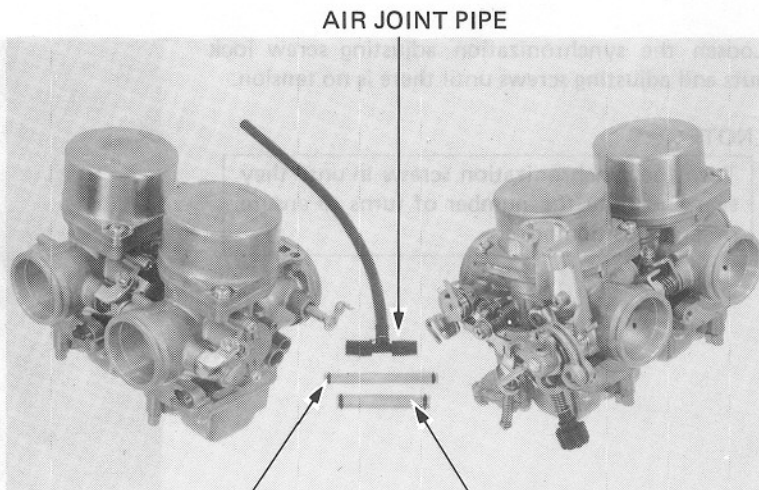



Remove the fuel inlet tube holder from the No. 1 carburetor.

NO. 1 CARBURETOR      INLET TUBE HOLDER

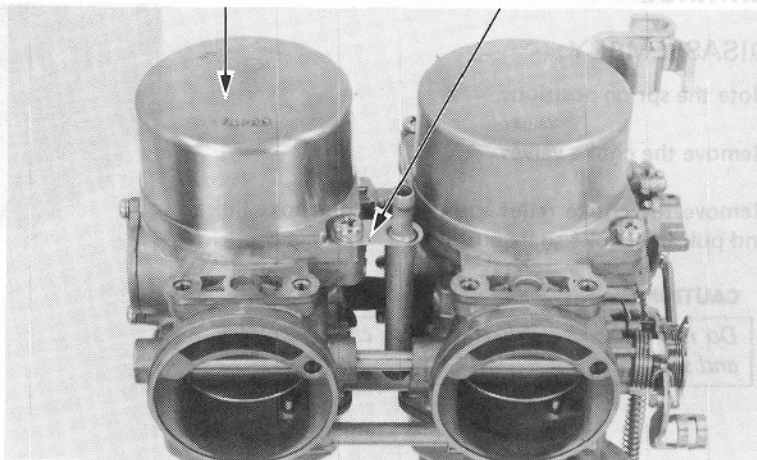

File the staked ends of the choke valve screws. Remove the choke valves and discard the screws.

**NOTE**

Do not allow the cut ends to enter the carburetors.

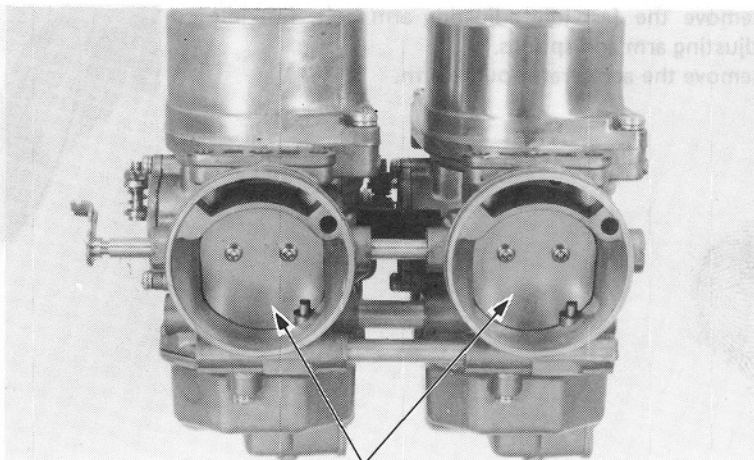

CHOKE VALVE

Carefully separate the individual carburetors.

**CAUTION**

Separate the carburetors horizontally to prevent damage to the joint pipes and choke linkage.

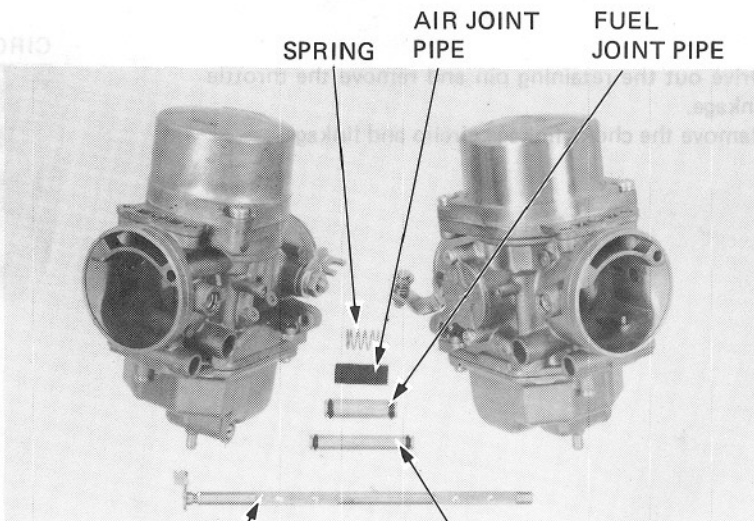

CHOKE SHAFT      ACCELERATOR PUMP JOINT PIPE

**FUEL SYSTEM**
**LINKAGE**
**DISASSEMBLY**

Note the spring positions.

Remove the choke valves.

Remove the choke relief spring from the choke link and pull the choke shaft out.

**CAUTION**

*Do not reuse the choke shaft, or choke valves and screws.*

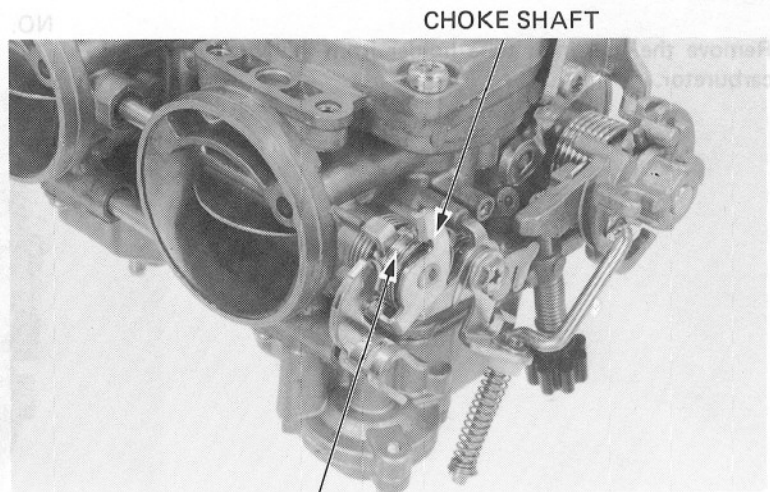

CHOKE SHAFT

CHOKE RELIEF SPRING

Remove the fast idle adjusting arm bolt, fast idle adjusting arm and springs.  
 Remove the accelerator pump arm.

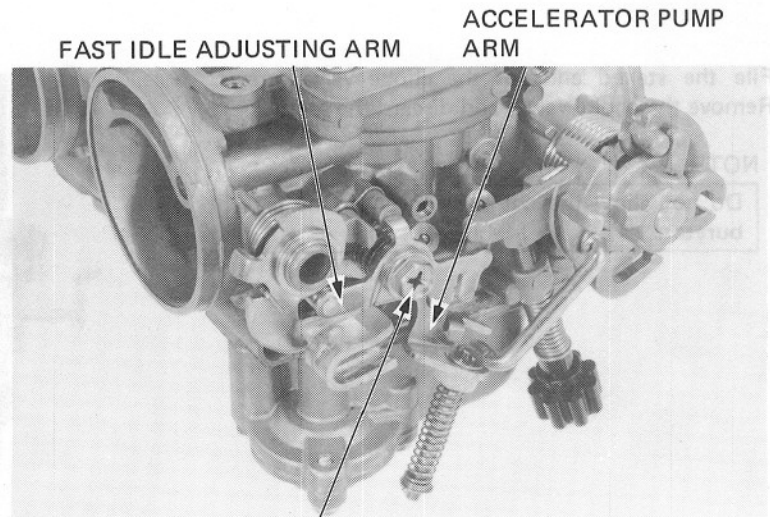

FAST IDLE ADJUSTING ARM

ACCELERATOR PUMP ARM

FAST IDLE ADJUSTING ARM BOLT

Drive out the retaining pin and remove the throttle linkage.  
 Remove the choke linkage circlip and linkage.

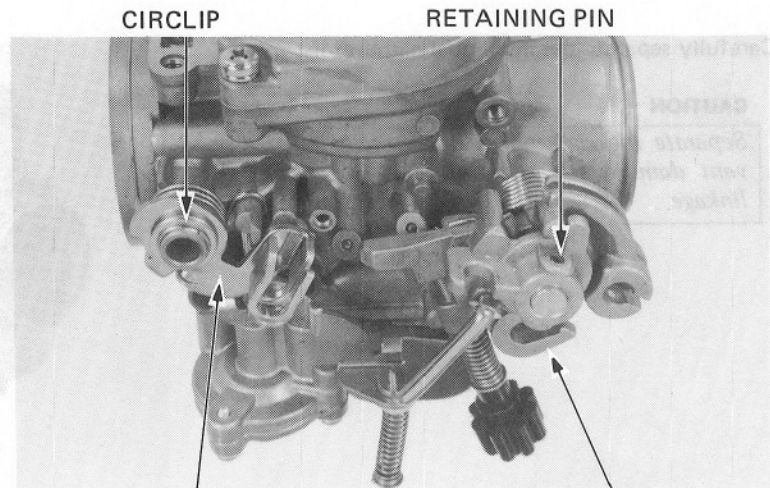

CIRCLIP

RETAINING PIN

CHOKE LINKAGE

THROTTLE LINKAGE



**ASSEMBLY**

To assemble the carburetor linkage, reverse the disassembly procedure.

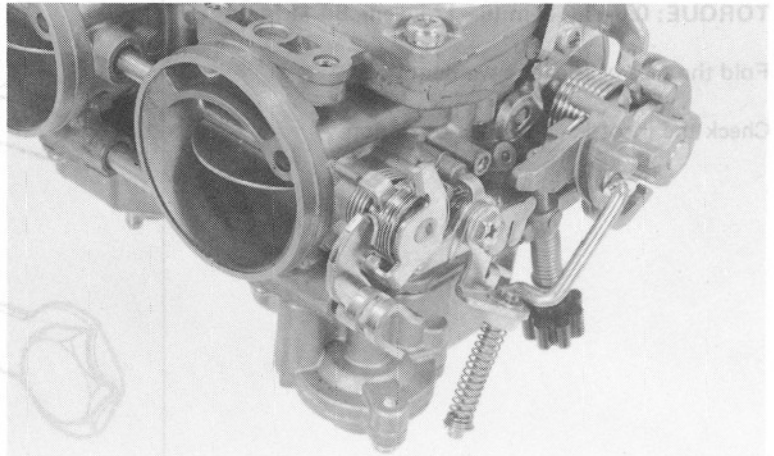
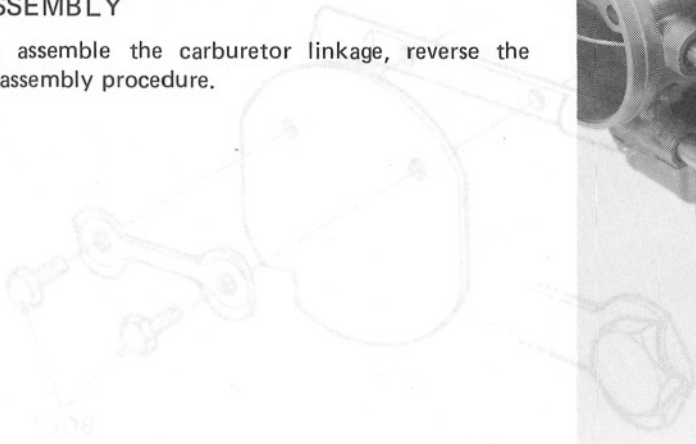

**CARBURETOR ASSEMBLY**

**NOTE**

Assemble one pair of carburetors at a time.

Install new o-rings on the fuel joint pipes.

**NOTE**

Apply a thin coating of oil to the o-rings.

Install the fuel joint, accelerator pump joint and air vent pipes.

Loosen the synchronization adjusting screw until there is no tension when assembling carburetors.

Insert the No. 3 carburetor throttle linkage between the plain washers.

Assemble the No. 3 and No. 4 carburetors, pressing them together carefully.

**NOTE**

The large washer should be positioned on the spring side.

Assemble the No. 1 and No. 2 carburetors in the same procedure as above.

Insert new choke shafts and assemble the carburetor linkage.

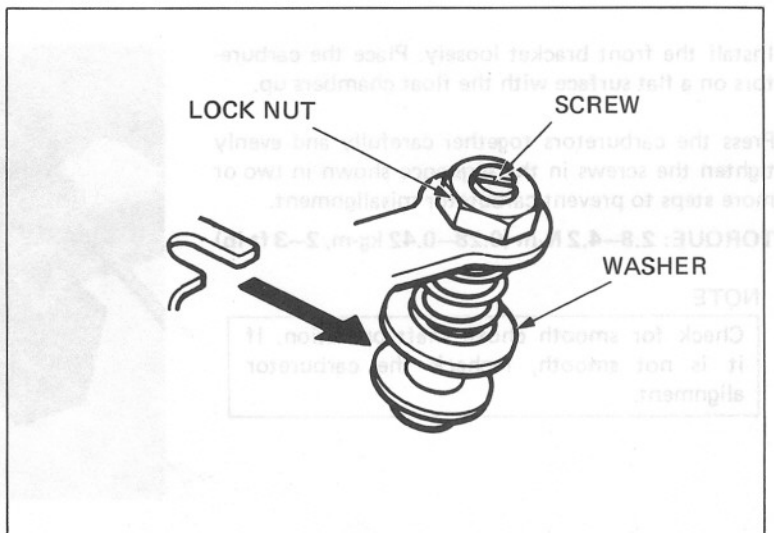
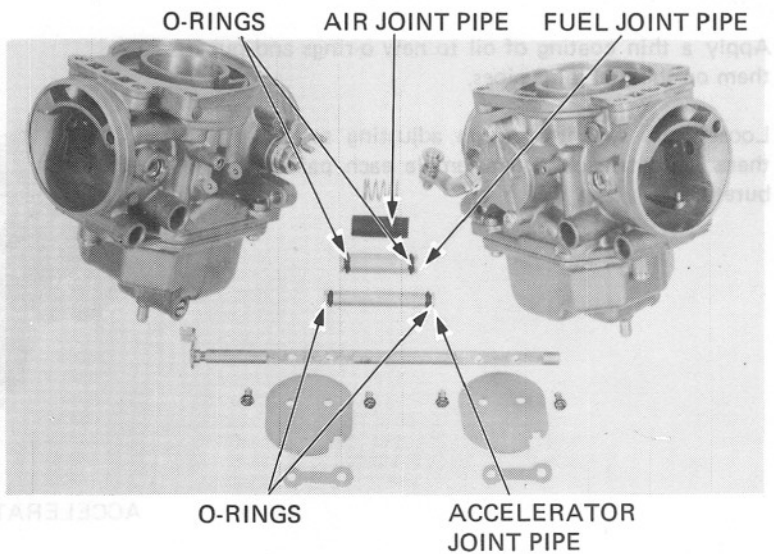



**FUEL SYSTEM**

Tighten the choke valve bolts.

**TORQUE: 0.6–1.2 N·m (6–12 kg·cm, 5–11 in·lb)**

Fold the tabs of the lock washer up.

Check the throttle and choke operation.

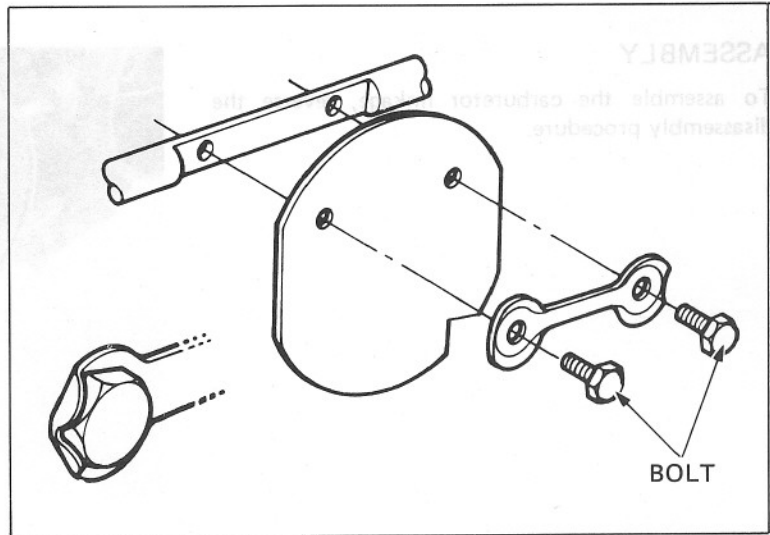

Apply a thin coating of oil to new o-rings and put them on the fuel joint pipes.

Loosen the synchronization adjusting screw until there is no tension and assemble each pair of carburetors.

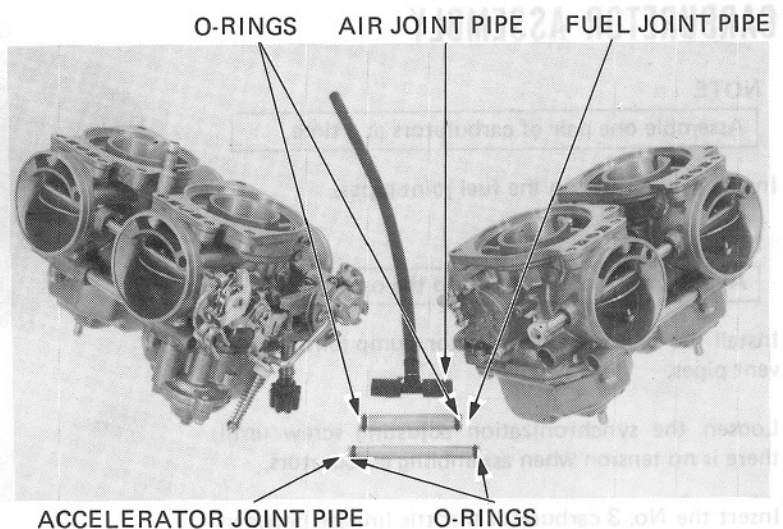

Install the front bracket loosely. Place the carburetors on a flat surface with the float chambers up.

Press the carburetors together carefully and evenly tighten the screws in the sequence shown in two or more steps to prevent carburetor misalignment.

**TORQUE: 2.8–4.2 N·m (0.28–0.42 kg·m, 2–3 ft·lb)**

**NOTE**

Check for smooth choke shaft operation. If it is not smooth, recheck the carburetor alignment.

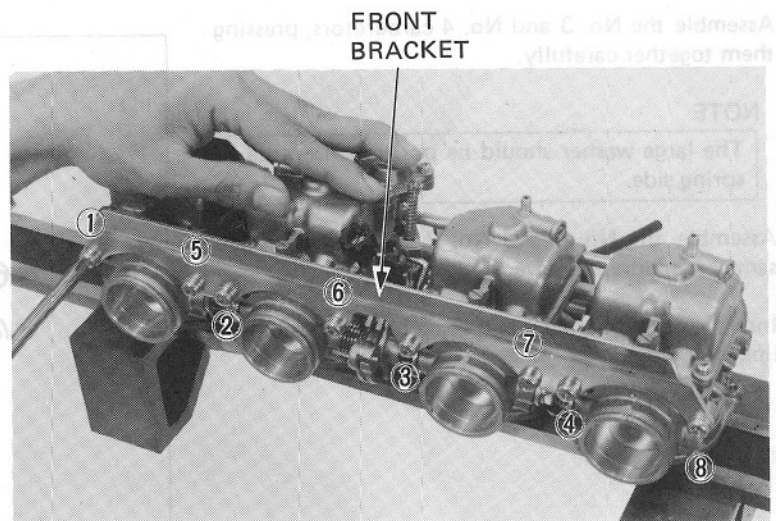



Install the rear bracket using the same procedure as for the front bracket.

**TORQUE: 2.8–4.2 N·m (0.28–0.42 kg·m, 2–3 ft·lb)**

Install the throttle cable holder.

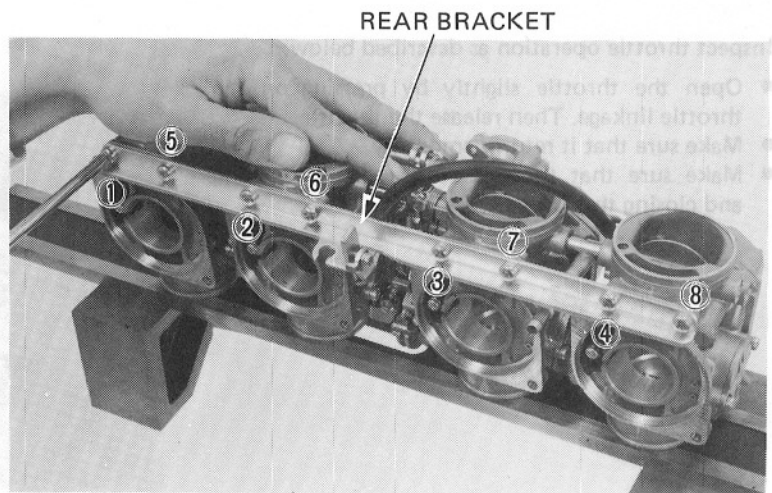

Install the thrust springs between the No. 1 and 2, and No. 3 and 4 carburetor throttle linkage.

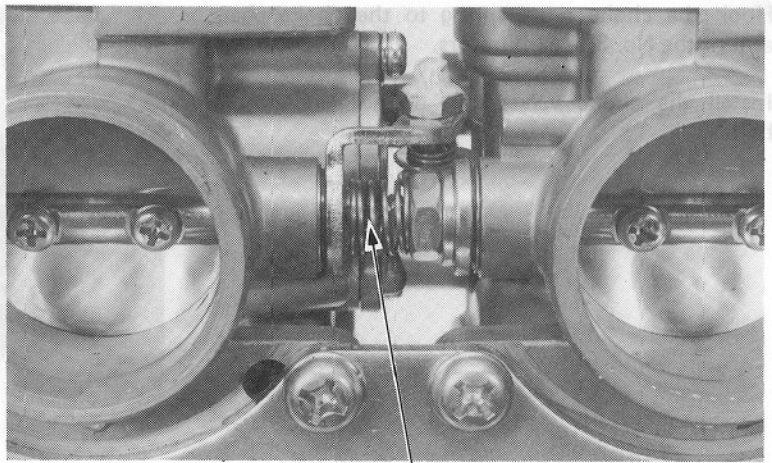

Turn each synchronization adjusting screw to its original position as noted during disassembly.

Make the distance between each by-pass hole and throttle valve equal.

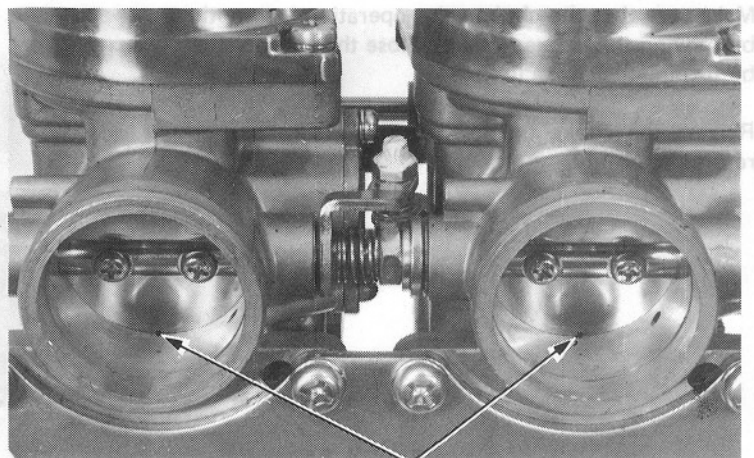

**FUEL SYSTEM**

Inspect throttle operation as described below:

- Open the throttle slightly by pressing on the throttle linkage. Then release the throttle.
- Make sure that it returns smoothly.
- Make sure that there is no drag when opening and closing the throttle.

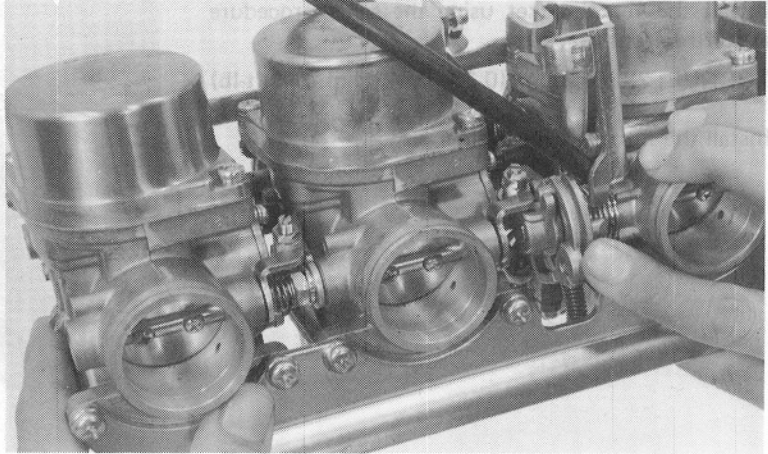

Hook the choke relief spring to the choke shaft arm of the No. 3, 4 carburetors.

Install the choke valves, but do not tighten the bolts.

RELIEF  
SPRING HOOK

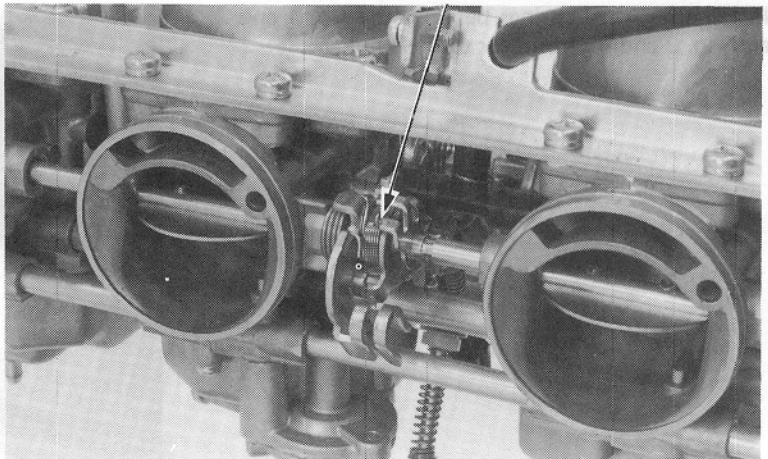

Make sure that the choke valve operation is smooth by moving the choke linkage. Close the choke valve by turning the choke linkage.

Release the choke linkage and make sure that it returns smoothly.

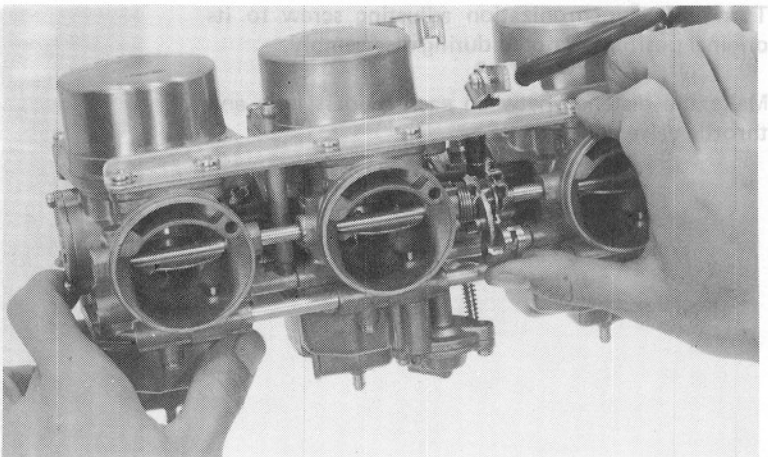



### FAST IDLE ADJUSTMENT

**FAST IDLE:** 1,000–2,500 rpm

Close the throttle valve and open the choke valve. Measure the clearance between the throttle link and fast idle adjusting arm pin.

**CLEARANCE:** 0.7–1.0 mm (0.03–0.04 in)

Bend the forked end of the fast idle adjusting arm open or closed to adjust.

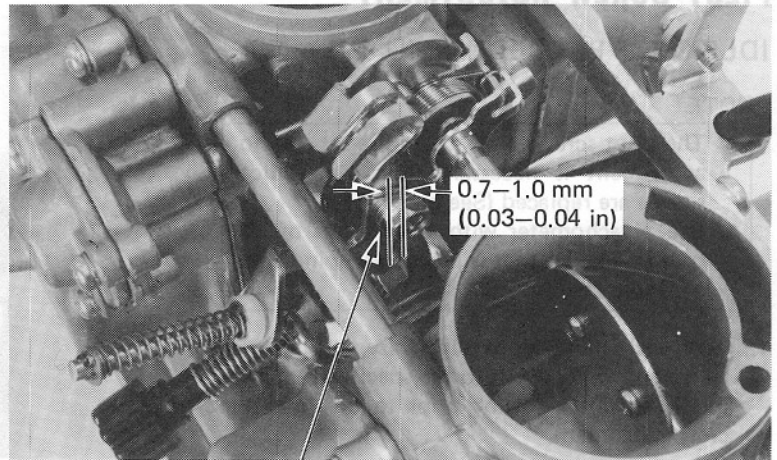

ADJUSTING ARM

### ACCELERATOR PUMP ADJUSTMENT

Measure the clearance between the accelerator pump rod and adjusting arm with the throttle valve closed.

**CLEARANCE:** 0–0.04 mm (0–0.0016 in)

Adjust by bending the adjusting arm.

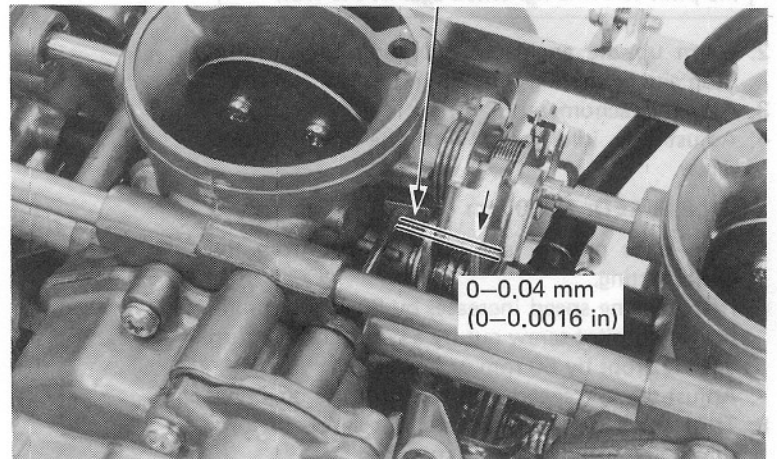

ADJUSTING ARM

### CARBURETOR INSTALLATION

The installation sequence is essentially the reverse of removal.

#### NOTE

Route the throttle and choke cables properly (Page 1-9 to 1-10).

Perform the following inspections and adjustments.

- Throttle operation (Page 3-4).
- Carburetor choke (Page 3-4).
- Carburetor idle speed (Page 3-12).

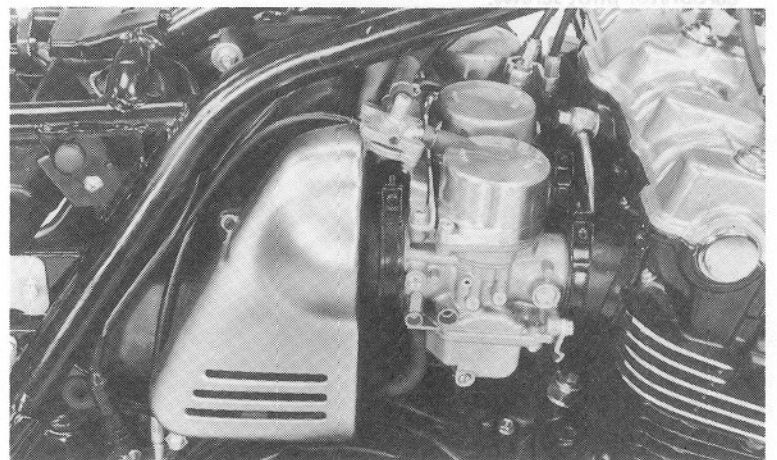



**FUEL SYSTEM**

**PILOT SCREW ADJUSTMENT**

**IDLE DROP PROCEDURE (U.S.A. only)**

**NOTE**

- The pilot screws are factory pre-set and no adjustment is necessary unless the pilot screws are replaced (See page 4-5).
- Use a tachometer with graduations of 50 rpm or smaller that will accurately indicate a 50 rpm change.

1. Turn each pilot screw clockwise until it seats lightly and back it out to the specification given. This is an initial setting prior to the final pilot screw adjustment.

**INITIAL OPENING: 2-1/2 turns out**

**CAUTION**

*Damage to the pilot screw seat will occur if the pilot screw is tightened against the seat.*

2. Warm up the engine to operating temperature. Stop and go driving for 10 minutes is sufficient.
3. Attach a tachometer.
4. Adjust the idle speed with the throttle stop screw.

**IDLE SPEED: 1,000 rpm**

5. Turn each pilot screw 1/2 turn out from the initial setting.
6. If the engine speed increases by 50 rpm or more, turn each pilot screw out by a continual 1/2 turn until it drops by 50 rpm or less.
7. Adjust the idle speed with the throttle stop screw.
8. Turn the No. 1 carburetor pilot screw in until the engine speed drops 50 rpm.
9. Turn the No. 1 carburetor pilot screw 1 turn out from the position obtained in step 8.
10. Adjust the idle speed with the throttle stop screw.
11. Perform steps 8, 9 and 10 for the No. 2, 3 and 4 carburetor pilot screws.

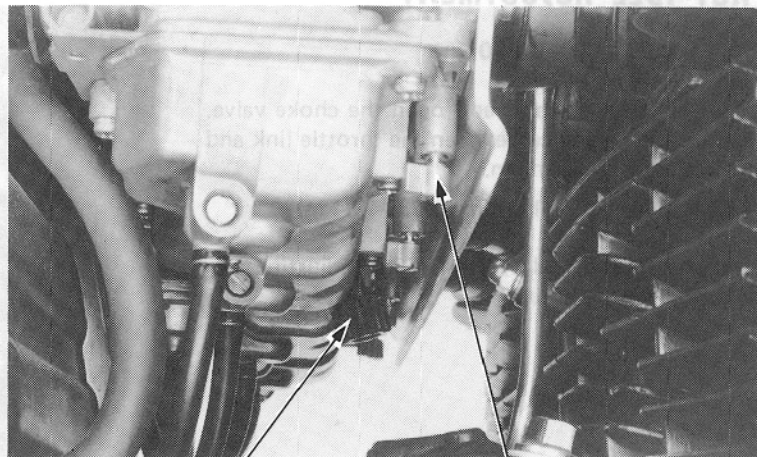

**THROTTLE STOP SCREW**

**PILOT SCREW**





### LIMITER CAP INSTALLATION

If the pilot screws are replaced, new limiter caps must be installed after pilot screw adjustment is completed.

After adjustment, cement the limiter cap over the pilot screw, using LOCTITE ® 601 or equivalent. The limiter cap should be placed against its stop, preventing further adjustment that would enrich the fuel mixture (limiter cap position permits clockwise rotation and prevents counterclockwise rotation).

#### NOTE

- Do not turn the pilot screws when installing the limiter caps.
- A pilot screw limiter cap must be installed. It prevents misadjustment that could cause poor performance and increase exhaust emissions.

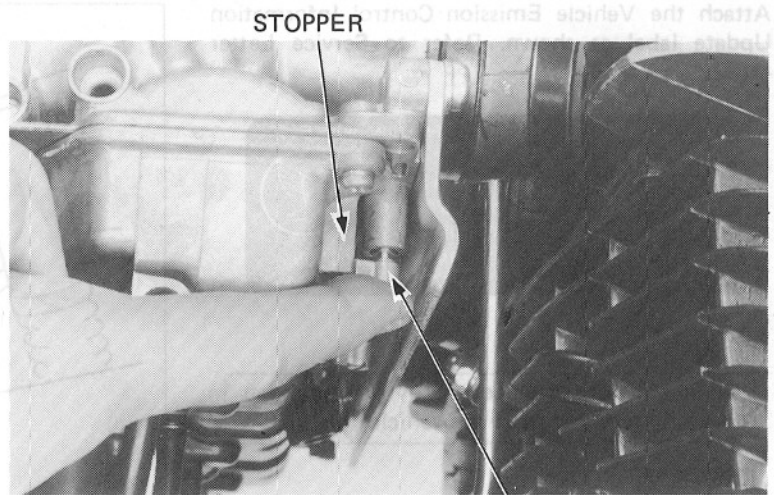

LIMITER CAP

### HIGH ALTITUDE ADJUSTMENT

When the vehicle is to be operated continuously above 6,500 feet (2,000 m), the carburetors must be readjusted as described below to improve driveability and decrease exhaust emissions.

Warm up the engine to operating temperature.

Stop-and-go driving for 10 minutes is sufficient to warm the engine.

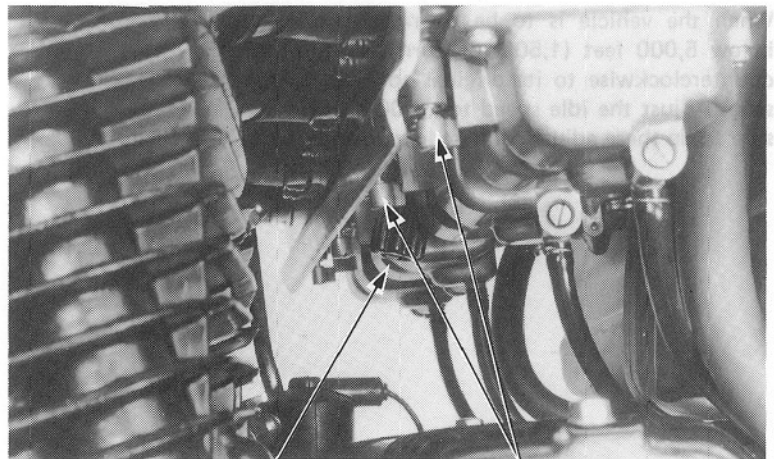

THROTTLE STOP SCREW

PILOT SCREWS

Turn each pilot screw clockwise 1/2 turn. Adjust the idle speed to 1,000 ± 100 rpm with the throttle stop screw.

#### NOTE

- These adjustments must be made at high altitude to ensure proper high altitude operation.

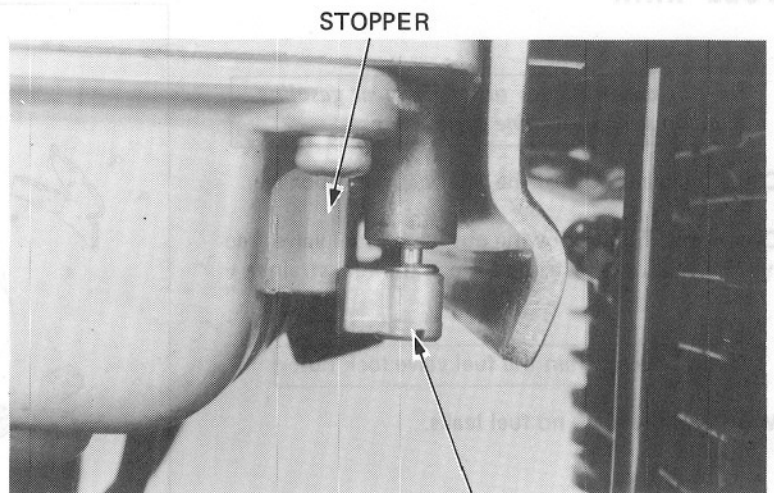

PILOT SCREW

## FUEL SYSTEM

Attach the Vehicle Emission Control Information Update Label as shown. Refer to Service Letter #132.

VEHICLE EMISSION CONTROL INFORMATION UPDATE  
 HONDA MOTOR CO., LTD.

THIS VEHICLE HAS BEEN ADJUSTED TO  
 IMPROVE EMISSION CONTROL PERFORMANCE  
 WHEN OPERATED AT HIGH ALTITUDE.  
 ALTITUDE PERFORMANCE ADJUSTMENT INSTRUCTIONS  
 ARE AVAILABLE AT YOUR AUTHORIZED HONDA DEALER.



### NOTE

Do not attach the label to any part that can be easily removed from the vehicle.

### WARNING

*Operation at any altitude lower than 5,000 feet (1,500 m) with the carburetors adjusted for high altitudes may cause the engine to idle roughly and stall.*

When the vehicle is to be operated continuously below 5,000 feet (1,500 m), turn each pilot screw counterclockwise to its original position against its stop. Adjust the idle speed to  $1,000 \pm 100$  rpm. Be sure to do these adjustments at low altitude.

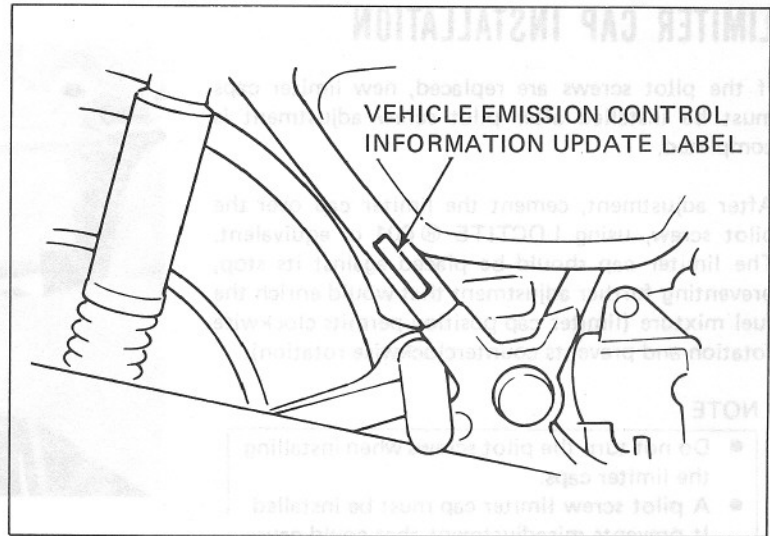

## FUEL TANK

### WARNING

*Do not allow flames or sparks near gasoline. Wipe up spilled gasoline at once.*

Check the vent hole of the filler cap for blockage.

Check that fuel is flowing out of the fuel valve freely. If fuel flow is restricted, clean the fuel strainer.

### NOTE

Do not overtighten the fuel valve lock nut.

Make sure there are no fuel leaks.

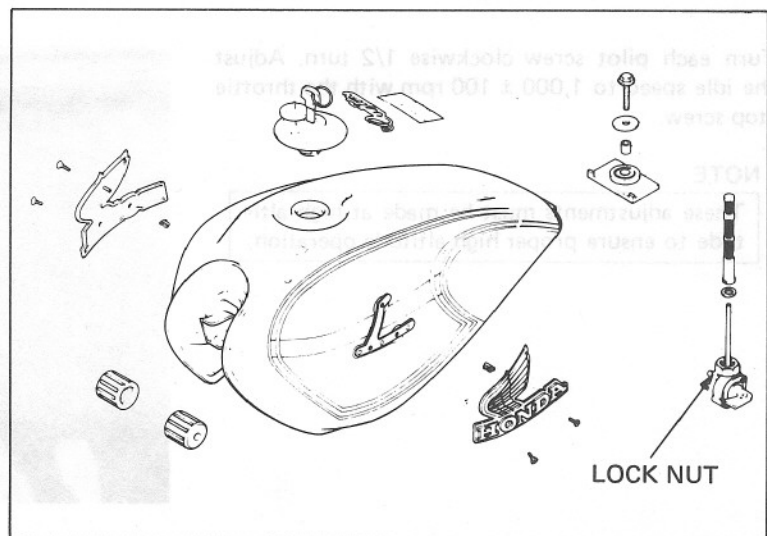



## AIR CLEANER

### CASE/CHAMBER

Check the air cleaner case for deterioration.

### CRANKCASE VENTILATION SYSTEM

Check that the breather tube is not restricted.

