



HONDA
CB1000C

23. TECHNICAL FEATURES

ANTI-DIVE FRONT SUSPENSION	23-2
OIL COOLER, OIL PUMP	23-3
DUAL RANGE SUBTRANSMISSION	23-4
SHAFT DRIVE	23-6

ANTI-DIVE FRONT SUSPENSION

GENERAL

This motorcycle has an anti-dive front suspension system with four-way adjustability to provide the desired ride under various braking conditions. The system consists of a piston, return spring, oil control orifice and body.

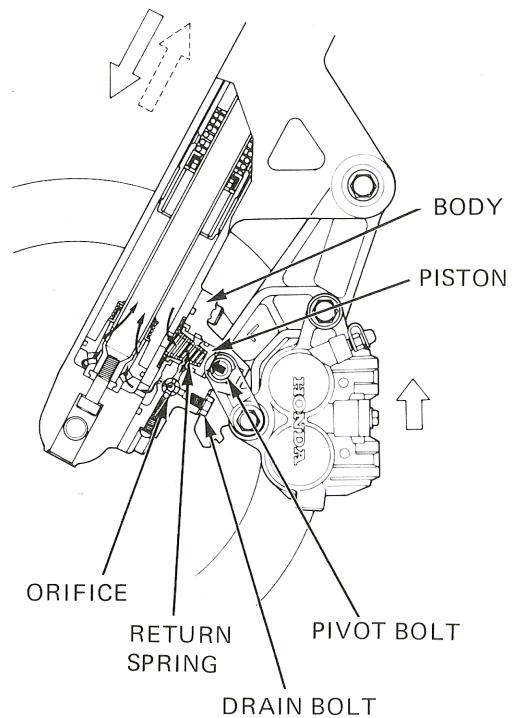
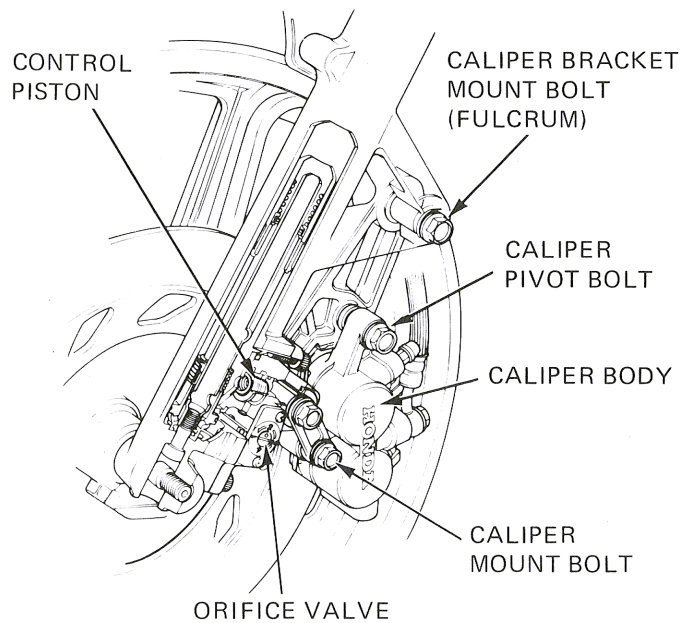

OPERATION

When the motorcycle is slowed or stopped, the brake disc is squeezed by the brake pads, causing the brake caliper to pivot on its bracket mounting bolt.

This movement causes the pivot bolt to push the piston in, uncovering the oil control orifice.

Since the orifice has four oil passages of different diameters, the desired damping can be selected by turning it. Always adjust the right and left to the same position.

Front Suspension Adjustment Chart

POSITION	DAMPING EFFECT
1	SOFT
2	STANDARD
3	FIRM
4	EXTRA FIRM

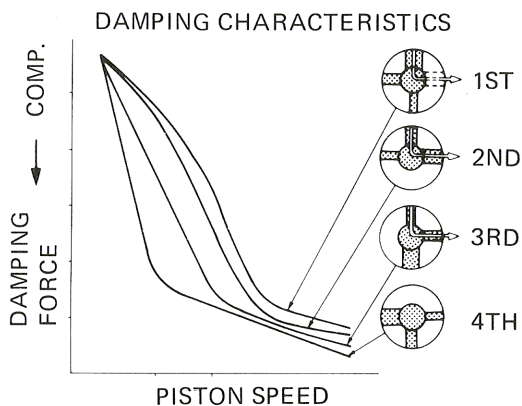



OIL COOLER, OIL PUMP

The engine uses a wet sump lubrication system in which the oil reservoir (sump) is the bottom of engine.

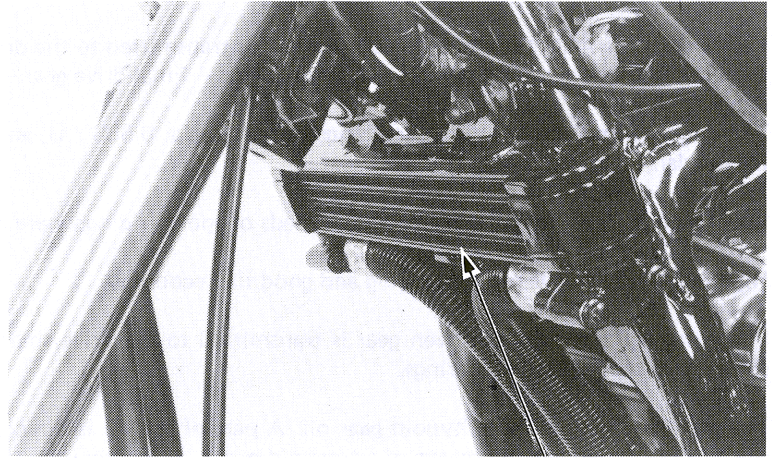

OIL COOLER

A tandem trochoid pump supplies oil to the bearings and other moving parts of the engine. Oil from the sump is forced by the main pump into the crankshaft and cylinder head. The auxiliary pump feeds oil to the primary shaft and transmission. The oil cooler is in the auxiliary pump circuit and cools the oil drawn from the sump by the auxiliary pump. The oil damper in the primary chain receives oil from this pump circuit.

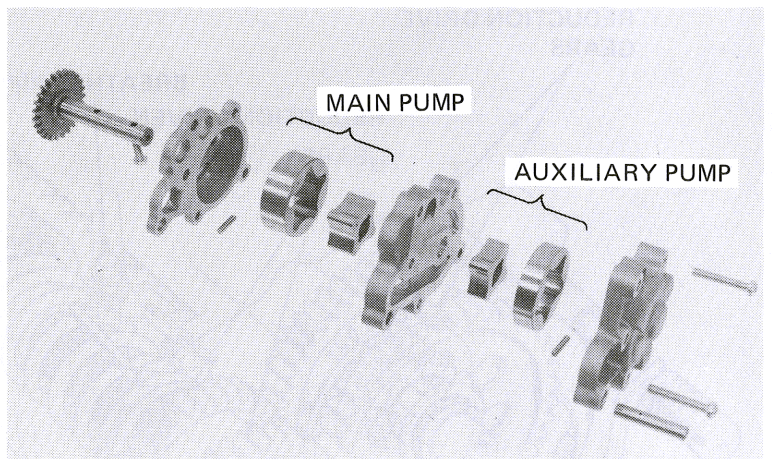

Oil from the sump must pass through a strainer before it enters the pumps.

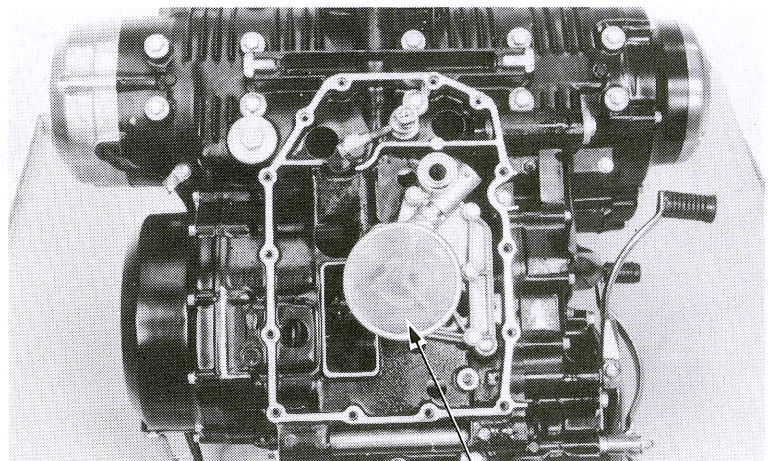

OIL STRAINER



DUAL RANGE SUBTRANSMISSION

Power from the main transmission countershaft is transmitted to the drive shaft as follows: Reduction drive gears (43T, 47T) – Reduction driven gears (31T, 30T) – Damper lifter – Final drive gear – Final driven gear – Drive shaft.

The dual transmission has two speed ranges, high (Ratio: 0.638 : 1), and low (Ratio: 0.721 : 1). Gear selection is by means of a foot pedal.

Low range (LO) – For winding mountain roads or sporty riding where extra power and acceleration are desired.

High range (HI) – For highway riding and good fuel economy.

Power from the reduction driven gear is transmitted to the drive shaft by means of bevel gears. The gears are spiral type and run on two tapered roller bearings.

The gear case is filled with hypoid gear oil. A part of the oil is directed under pressure through the passage in the drive gear shaft to the driven gear by means of a trochoid pump. A breather controls the oil pressure within the case.

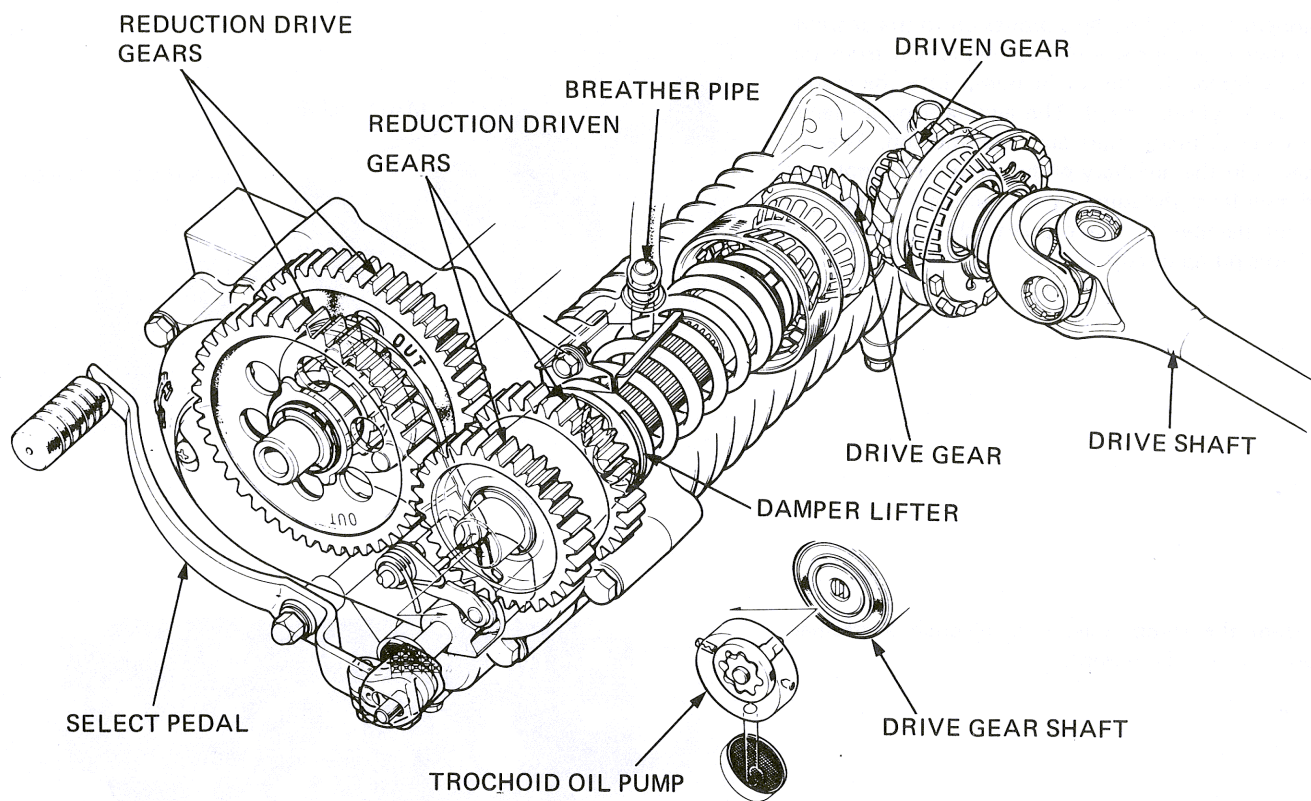



The damper uses a lifter, spring and cam which is integrated with the reduction driven gear. The lifter and reduction driven gear fit on the end of the shaft. The reduction gear is free wheeling and the lifter is splined. It is held against the cam by means of the spring.

During acceleration or deceleration, the lifter rides over the cam, compressing the spring. The relative movement between the lifter and cam, relieves the shock imposed on the driveline components.

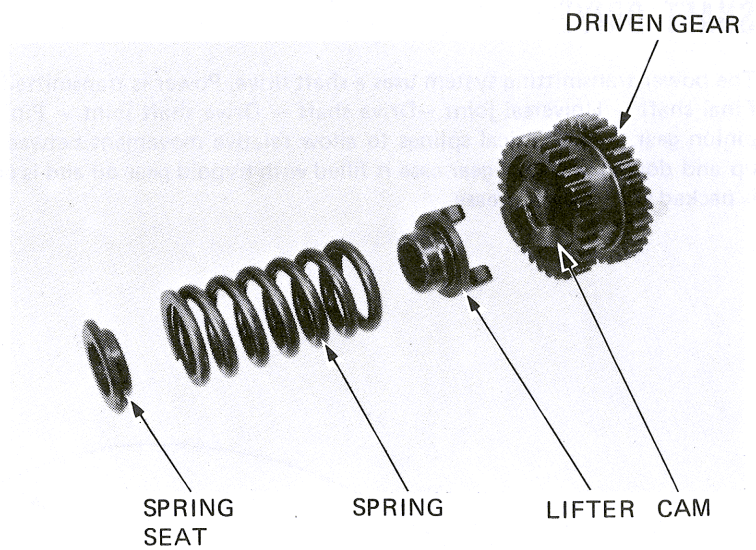

SHAFT DRIVE

The power transmitting system uses a shaft drive. Power is transmitted by way of:

Final shaft – Universal joint – Drive shaft – Drive shaft joint – Pinion gear – Ring gear – Driven flange – Rear wheel. The pinion gear uses spherical splines to allow relative movement between the drive shaft and this gear when the rear wheel moves up and down. The final gear case is filled with hypoid gear oil and is equipped with a breather. The pinion gear bearing retainer is packed with special grease.

