

HYDRAULIC BRAKES

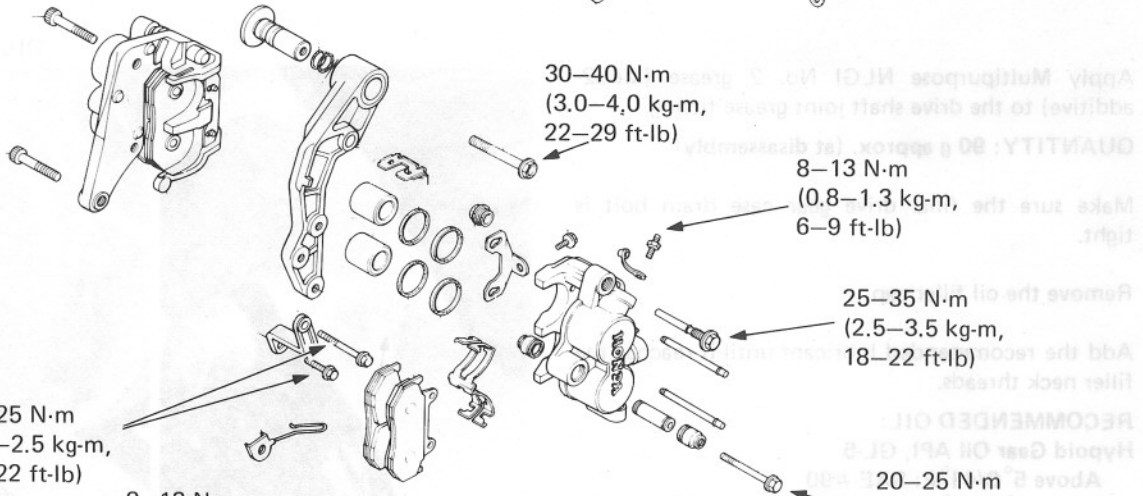

HONDA CB100C

FRONT:

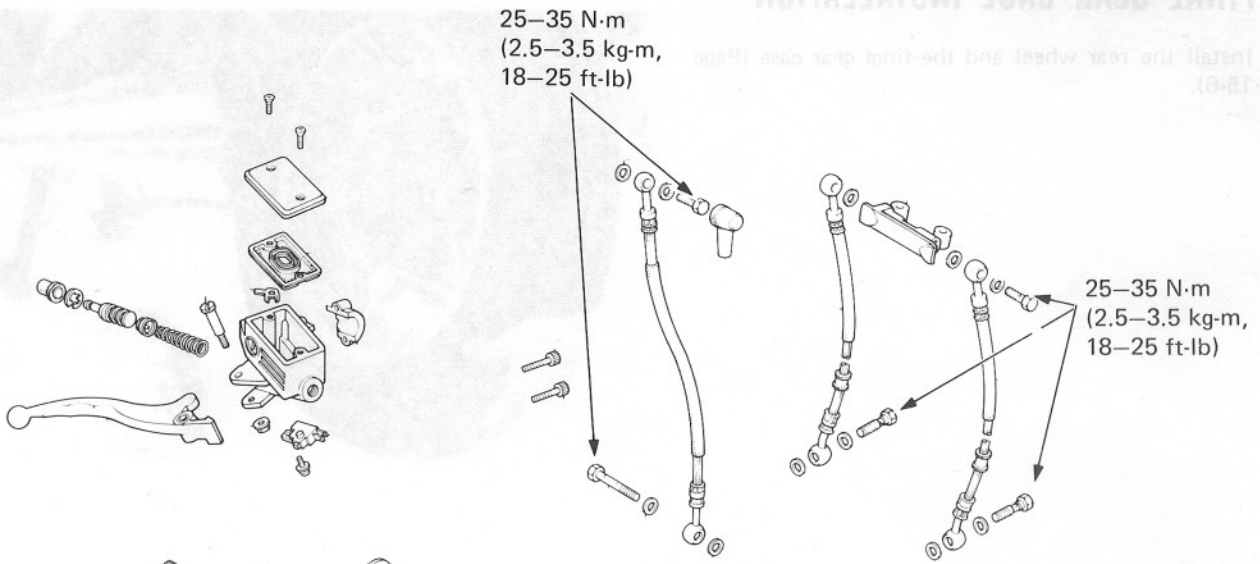

REAR:

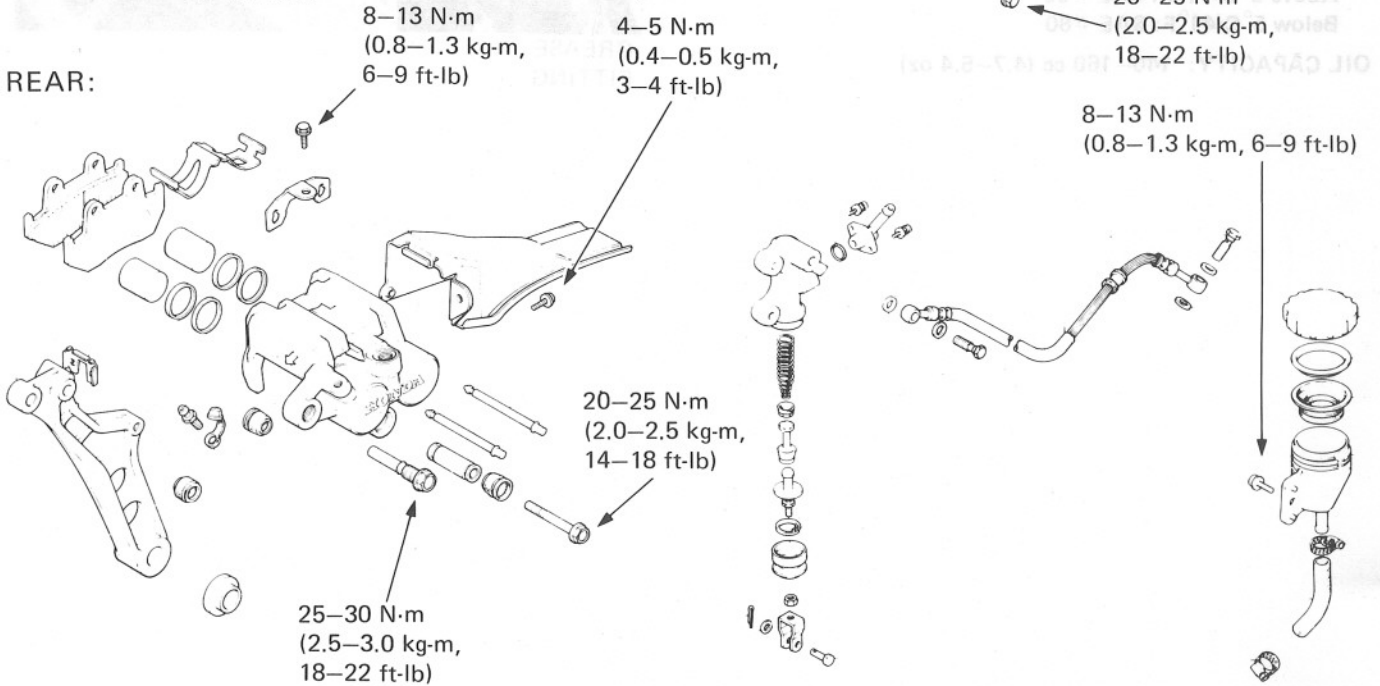



SERVICE INFORMATION	17- 1
TROUBLESHOOTING	17- 2
BRAKE FLUID REPLACEMENT/ AIR BLEEDING	17- 3
BRAKE PAD/DISC	17- 5
FRONT MASTER CYLINDER	17- 9
FRONT BRAKE CALIPER	17-11
REAR MASTER CYLINDER	17-15
REAR BRAKE CALIPER	17-17
BRAKE PEDAL SHAFT	17-20

SERVICE INFORMATION

GENERAL

- The front and rear brakes can be removed without disconnecting the hydraulic system.
- Once the hydraulic systems have been opened, or if the brakes feel spongy, the system must be bled.
- Do not allow foreign material to enter the system when filling the reservoirs.
- Avoid spilling brake fluid on painted surfaces or instrument lenses, as severe damage will result.
- Always check brake operation before riding the motorcycle.

SPECIFICATIONS

	STANDARD	SERVICE LIMIT
Front disc thickness	4.8–5.2 mm (0.19–0.21 in)	4.0 mm (0.16 in)
Front disc warpage	—————	0.30 mm (0.012 in)
Front master cylinder I.D.	14.000–14.043 mm (0.5512–0.5529 in)	14.055 mm (0.5533 in)
Front master piston O.D.	13.957–13.984 mm (0.5495–0.5506 in)	13.940 mm (0.5488 in)
Front caliper piston O.D.	30.148–30.198 mm (1.1869–1.1889 in)	30.14 mm (1.187 in)
Front caliper cylinder I.D.	30.23–30.28 mm (1.190–1.192 in)	30.29 mm (1.193 in)
Rear master cylinder I.D.	14.000–14.043 mm (0.5512–0.5529 in)	14.06 mm (0.553 in)
Rear master piston O.D.	13.957–13.984 mm (0.5495–0.5506 in)	13.940 mm (0.5488 in)
Rear caliper cylinder I.D.	30.23–30.28 mm (1.1901–1.1921 in)	30.29 mm (1.193 in)
Rear caliper piston O.D.	30.148–30.198 mm (1.1869–1.1889 in)	30.14 mm (1.187 in)
Rear disc thickness	6.8–7.2 mm (0.27–0.28 in)	6.0 mm (0.24 in)
Rear disc runout	—————	0.30 mm (0.012 in)



TORQUE VALUES

Oil bolt	25-35 N·m (2.5-3.5 kg-m, 18-25 ft-lb)
Caliper bleed valve	4- 7 N·m (0.4-0.7 kg-m, 3- 5 ft-lb)
Pin retainer	8-13 N·m (0.8-1.3 kg-m, 6- 9 ft-lb)
Front brake disc	25-30 N·m (2.5-3.0 kg-m, 18-22 ft-lb)
Front caliper bracket (Right)	30-40 N·m (3.0-4.0 kg-m, 22-29 ft-lb)
Upper mount bolt (Left)	30-40 N·m (3.0-4.0 kg-m, 22-29 ft-lb)
Piston pin bolt (Left)	20-25 N·m (2.0-2.5 kg-m, 14-18 ft-lb)
Lower mount bolt (Left)	20-25 N·m (2.0-2.5 kg-m, 14-18 ft-lb)
Front caliper bolt	20-25 N·m (2.0-2.5 kg-m, 14-18 ft-lb)
Front caliper shaft	25-30 N·m (2.5-3.0 kg-m, 18-22 ft-lb)
Rear brake disc	27-33 N·m (2.7-3.3 kg-m, 20-24 ft-lb)
Rear brake torque rod nut	18-25 N·m (1.8-2.5 kg-m, 13-18 ft-lb)
Rear caliper bolt	20-25 N·m (2.0-2.5 kg-m, 14-18 ft-lb)
Rear caliper shaft	25-30 N·m (2.5-3.0 kg-m, 18-22 ft-lb)
Dust cover	4- 5 N·m (0.4-0.5 kg-m, 3- 4 ft-lb)
Rear master cylinder oil reservoir	8-13 N·m (0.8-1.3 kg-m, 6- 9 ft-lb)
Rear master cylinder	20-25 N·m (2.0-2.5 kg-m, 14-18 ft-lb)

TOOL

- Special
Snap ring pliers 07914-3230001

TROUBLESHOOTING

Brake Lever/Pedal Soft or Spongy

1. Air bubbles in hydraulic system.
2. Low fluid level.
3. Hydraulic system leaking.

Brake Lever/Pedal Too Hard

1. Sticking piston(s).
2. Clogged hydraulic system.
3. Pads glazed or worn excessively.

Brakes Drag

1. Hydraulic system sticking.
2. Incorrect adjustment of lever or pedal.
3. Sticking piston(s).

Brakes Grab or Pull to One Side

1. Pads contaminated.
2. Disc or wheel misaligned.

Brakes Chatter or Squeal

1. Pads contaminated.
2. Excessive disc runout.
3. Caliper installed incorrectly.
4. Disc or wheel misaligned.

SERVICE INFORMATION

GENERAL

- The front and rear brakes cannot be adjusted.
- Once the hydraulic system has been bled, do not allow air to enter the system.
- Do not allow foreign material to enter the system when filling the reservoir.
- Avoid spilling brake fluid on painted surfaces.
- Always check brake pads for wear and replace if necessary.

SPECIFICATIONS

Front disc thickness

Front disc width

Front master cylinder

Front master cylinder

Front caliper width

Front caliper height

Rear master cylinder

Rear master cylinder

Rear caliper width

Rear caliper height

Rear disc thickness

Rear disc width



BRAKE FLUID REPLACEMENT/AIR BLEEDING

Check the fluid level with the fluid reservoir parallel to the ground.

CAUTION

- Install the diaphragm on the reservoir when operating the brake lever/pedal. Failure to do so will allow brake fluid to squirt out of the reservoir during brake operation.
- Avoid spilling fluid on painted surfaces. Place a rag over the fuel tank whenever the system is serviced.

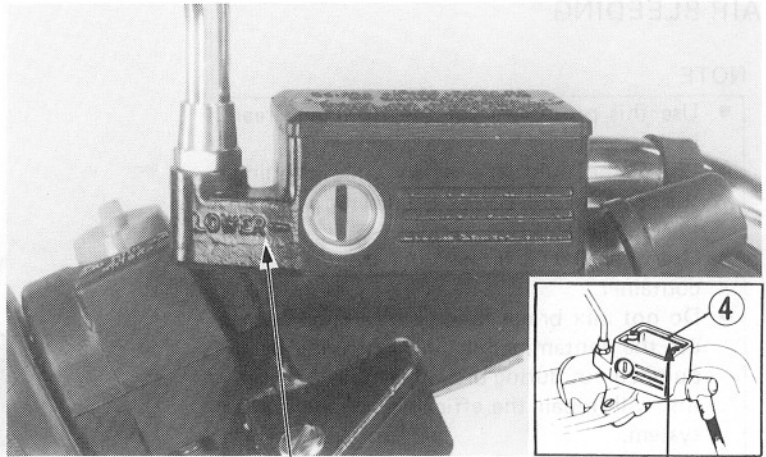

LOWER LEVEL

UPPER LEVEL

BRAKE FLUID DRAINING

Connect a bleed hose to the bleeder valve. Loosen the caliper bleeder valve and pump the brake lever (or pedal). Stop operating the lever (or pedal) when no fluid flows out of the bleeder valve.

WARNING

A contaminated brake disc or pad reduces stopping power. Discard contaminated pads and clean a contaminated disc with a high quality brake degreasing agent.

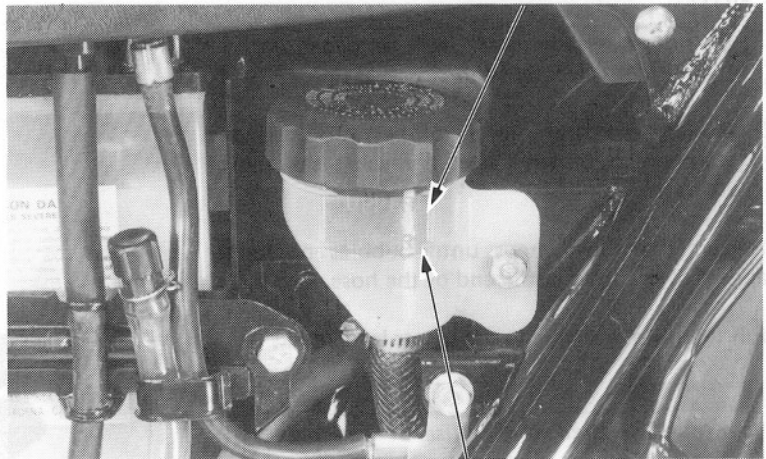

UPPER LEVEL

LOWER LEVEL

BRAKE FLUID FILLING

NOTE

Do not mix different types of fluid since they may not be compatible.

Close the bleeder valve, fill the reservoir, and install the diaphragm.

To prevent piston overtravel and brake fluid see page, keep a 20 mm (3/4 in) space to the handlebar grip when bleeding the front brake system. Pump up the system pressure with the lever until there are no air bubbles in the fluid flowing out of the reservoir small hole and lever (or pedal) resistance is felt.



AIR BLEEDING

NOTE

- Use this procedure for the front and rear brakes.
- Check the fluid level often while bleeding the brake to prevent air from being pumped into the system.
- Use only DOT3 brake fluid from a sealed container.
- Do not mix brake fluid types and never reuse the contaminated fluid which has been pumped out during brake bleeding, because this will impair the efficiency of the brake system.

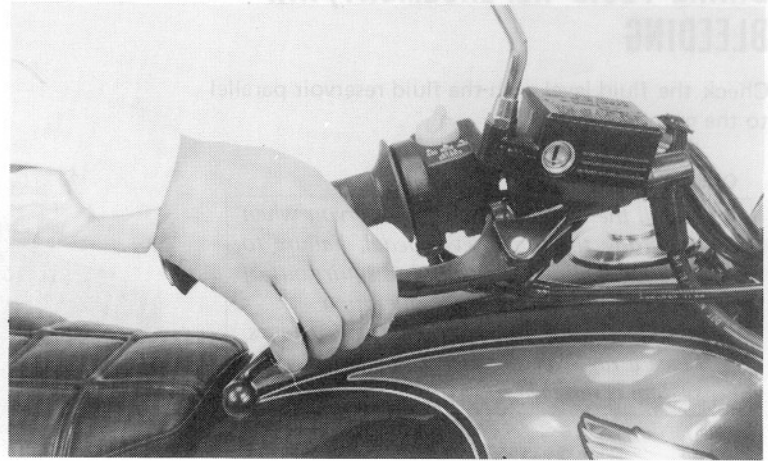

1. Squeeze the brake lever (or depress the brake pedal), open the bleeder valve 1/2 turn then close the valve.

NOTE

Do not release the brake lever (or pedal) until the bleeder valve has been closed again.

2. Release the brake lever (or pedal) slowly and wait several seconds after it reaches the end of its travel.

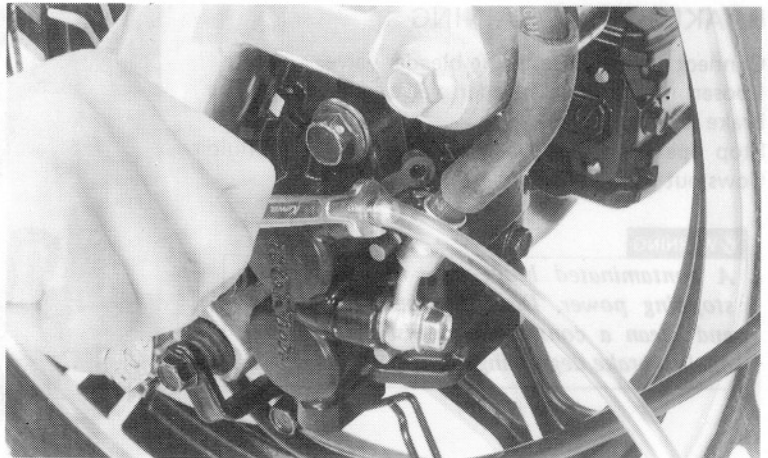

Repeat the above steps until bubbles no longer appear in the fluid at the end of the hose.

Fill the fluid reservoir to the upper level mark.

WARNING

A contaminated brake disc or pad reduces stopping power. Discard contaminated pads and clean a contaminated disc with a high quality brake degreasing agent.

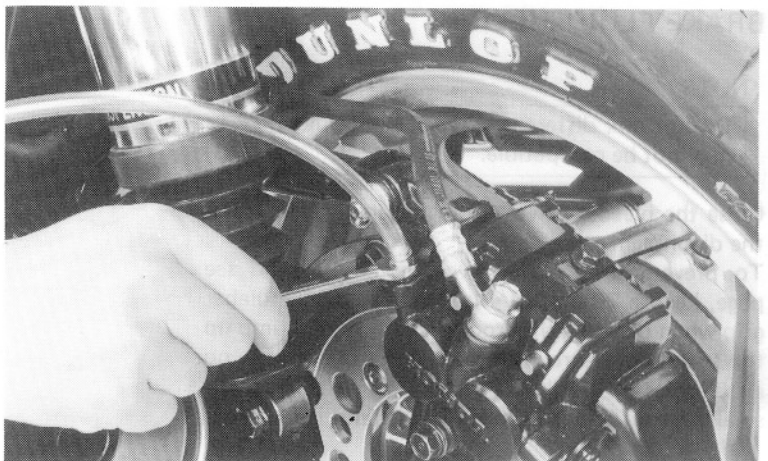



BRAKE PAD/DISC

FRONT PAD REPLACEMENT

Check the brake pads for wear by looking through the slot pointed to by the cast arrow on the caliper assembly.

Replace the brake pads if the wear line on the pads reaches the edge of the brake disc.

NOTE

Always replace the brake pads in pairs to assure even disc pressure.

Remove the pad pin retainer and caliper bolts. Pivot the caliper up out of the way.

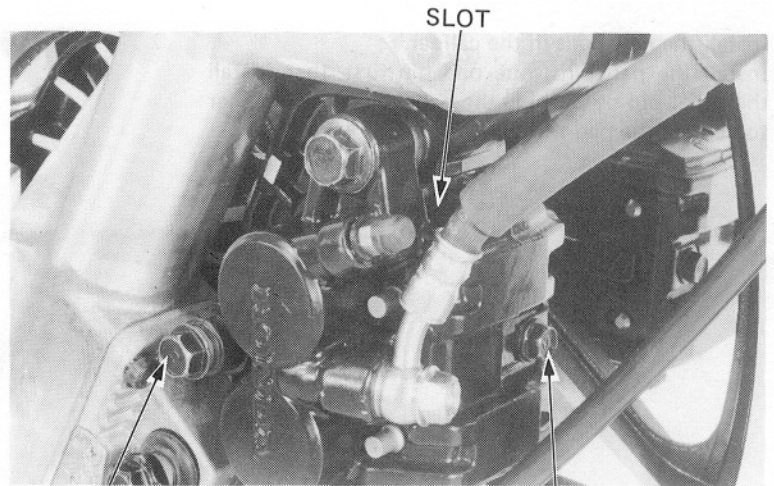

CALIPER BOLT

PAD PIN RETAINER BOLT

Remove the pad pin retainer and pull the pad pins out of the caliper. Remove the brake pads.

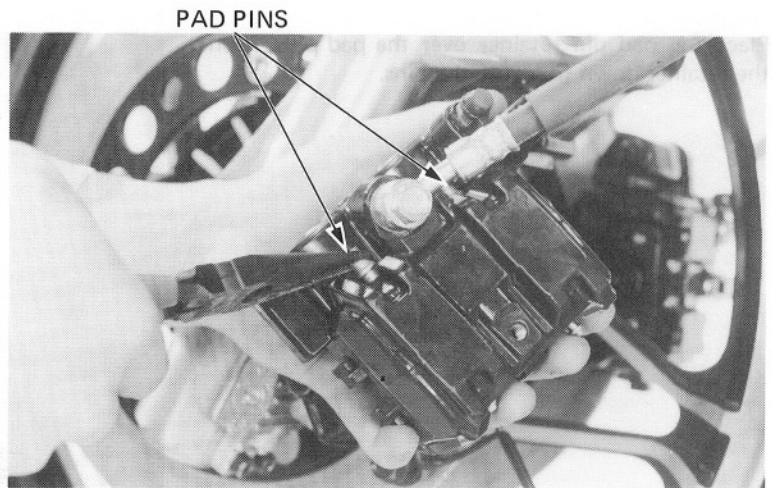

PAD PINS

Position the pad spring in the caliper as shown. Push the caliper pistons in all the way.

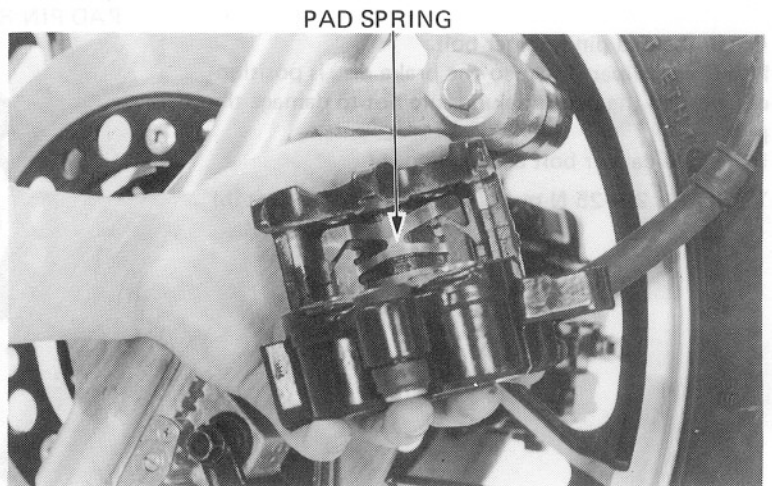

PAD SPRING



HYDRAULIC BRAKES

Install the new pads in the caliper.
Install the pad pins, one pad pin first, then install the other pin by pushing the pads against the caliper to depress the pad spring.

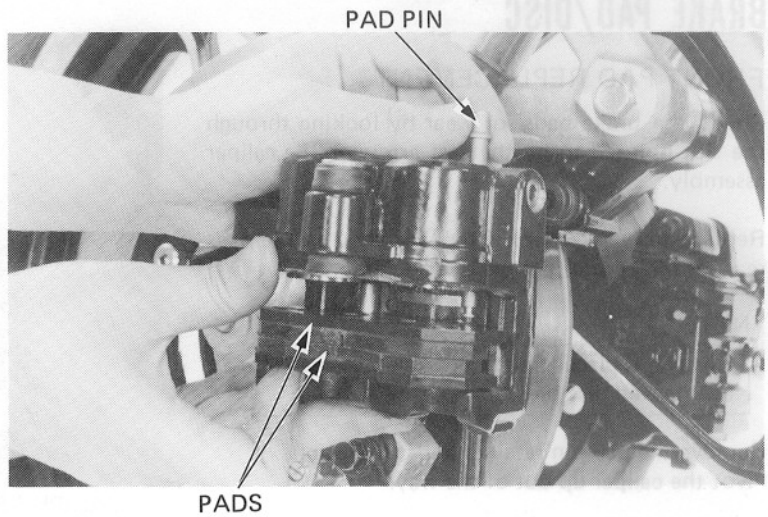

Place the pad pin retainer over the pad pins. Push the retainer down to secure the pins.

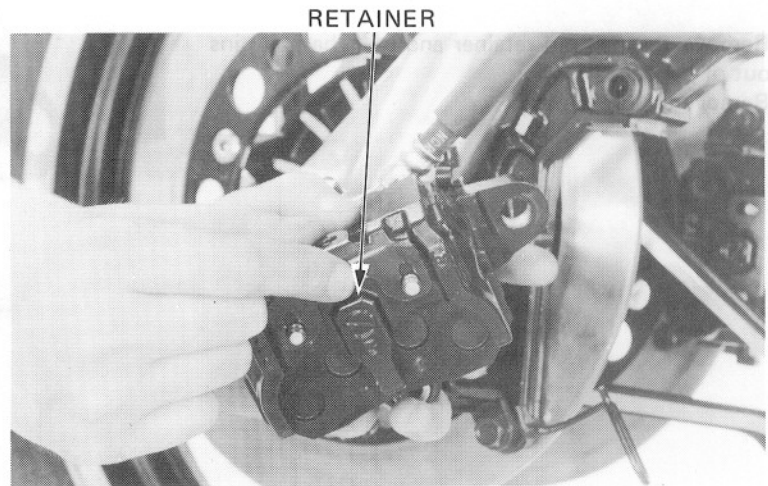

Install the pad pin retainer bolt.
Pivot the caliper down so the brake disc is positioned between the pads, making sure not to damage the pads.

Install the caliper bolt and tighten it.

TORQUE: 20–25 N·m (2.0–2.5 kg·m, 14–18 ft·lb)

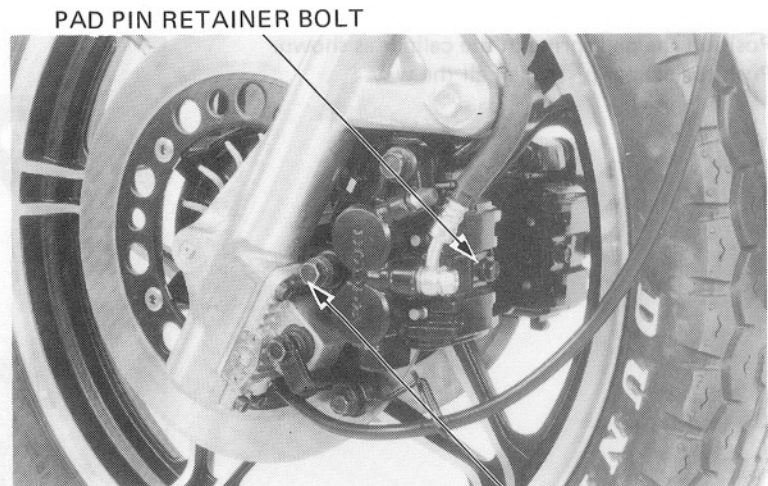



REAR BRAKE PAD REPLACEMENT

Check the brake pads for wear by looking through the slot pointed to by the cast arrow on the caliper assembly.

Replace the brake pads if the wear line on the pads reaches the edge of the brake disc.

NOTE

Always replace the brake pads in pairs to assure even disc pressure.

Remove the dust cover and pad pin retainer.

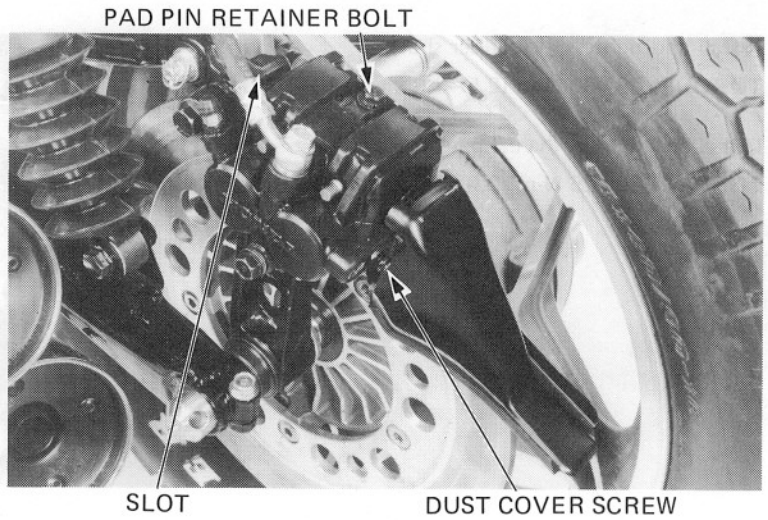

Remove the caliper bolt and caliper shaft.
Remove the caliper from the caliper bracket.

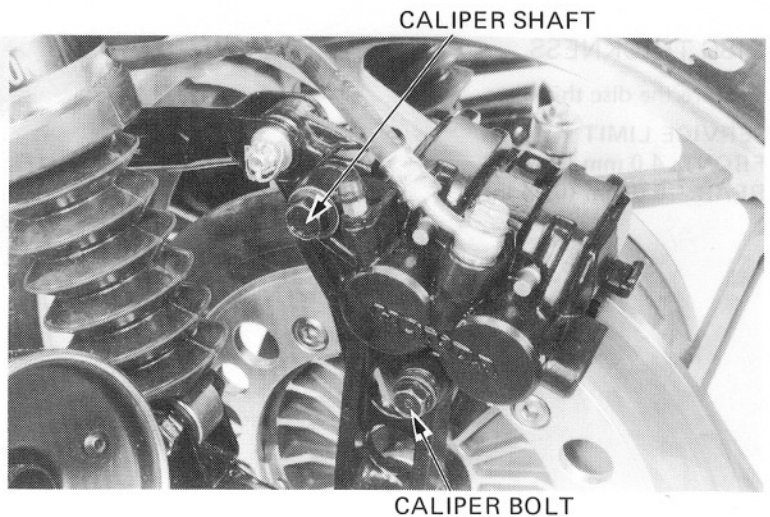

Pull out the two pad pins and remove the pads from the caliper.

Install the pad pins, one pad pin first, then install the other pin by pushing the pads against the caliper to depress the pad spring.

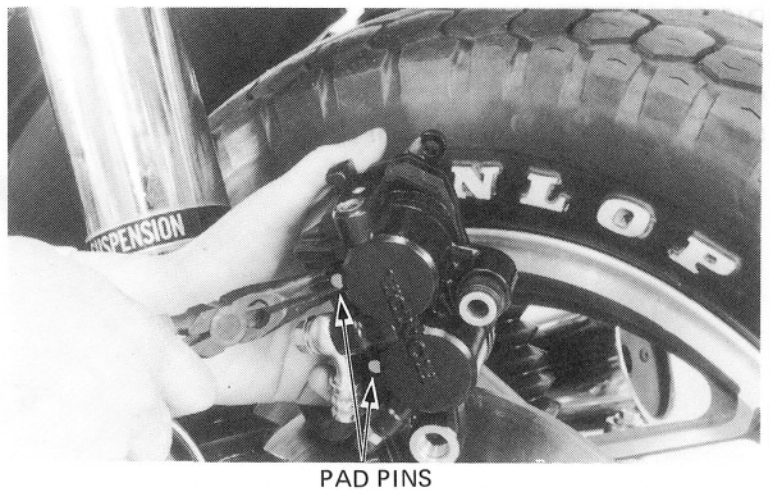



HYDRAULIC BRAKES

Install and tighten the caliper shaft.

TORQUE: 25–30 N·m (2.5–3.0 kg·m, 18–22 ft·lb)

Install and tighten the caliper bolt.

TORQUE: 20–25 N·m (2.0–2.5 kg·m, 14–18 ft·lb)

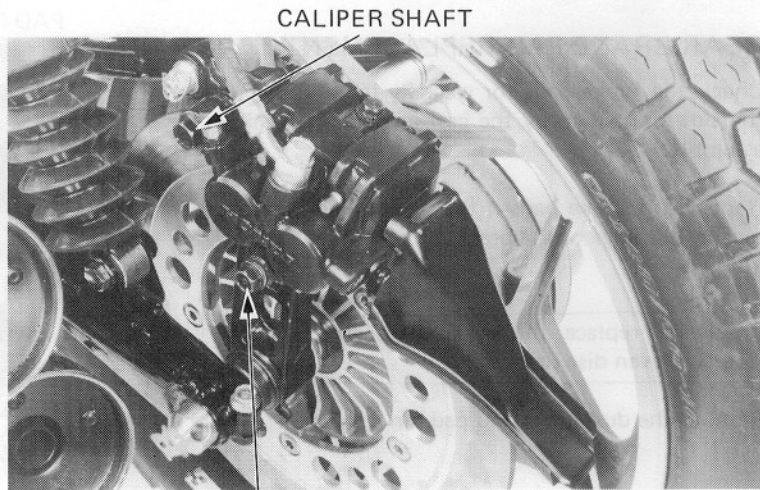

CALIPER BOLT

DISC THICKNESS

Measure the disc thickness.

SERVICE LIMIT

FRONT: 4.0 mm (0.16 in)

REAR: 6.0 mm (0.24 in)

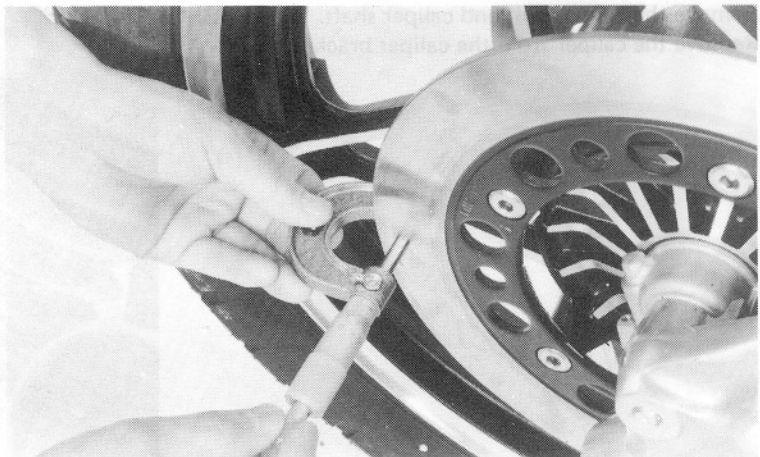

DISC WARPAGE

Measure the brake disc warpage on a surface plate with a dial indicator.

SERVICE LIMIT: 0.3 mm (0.012 in)

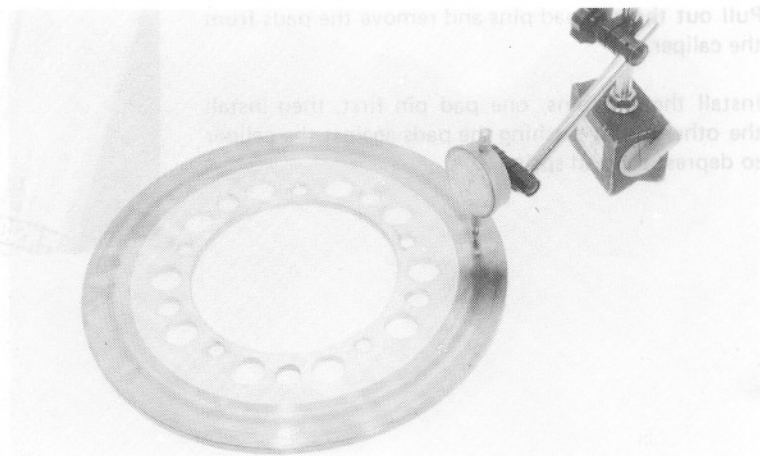



FRONT MASTER CYLINDER

DISASSEMBLY

Drain brake fluid from the hydraulic system.
Remove the brake lever and rear view mirror from the master cylinder. Disconnect the brake hose.

CAUTION

Avoid spilling brake fluid on painted surfaces. Place a rag over the fuel tank whenever the brake system is serviced.

NOTE

When removing the oil hose bolt, cover the end of the hose to prevent contamination. Secure the hose to prevent fluid from leaking out.

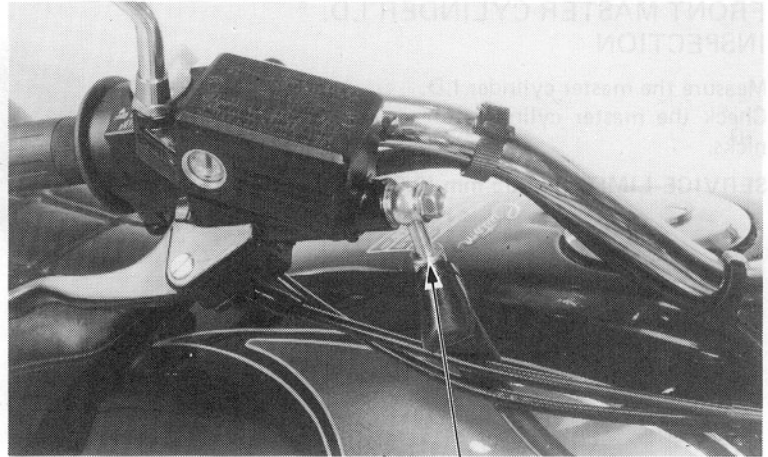

BRAKE HOSE

Remove the master cylinder.

Remove the piston boot and the circlip from the master cylinder body.



SNAP RING PLIERS
07914-3230001

Remove the secondary cup and piston. Then remove the primary cup and spring.

Remove the brake light switch from the master cylinder body, if necessary.

Clean the inside of the master cylinder and reservoir with brake fluid.

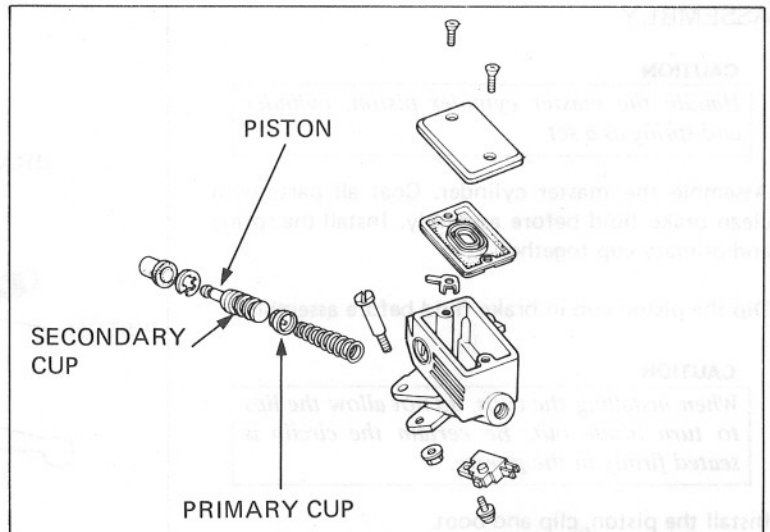



HYDRAULIC BRAKES

FRONT MASTER CYLINDER I.D. INSPECTION

Measure the master cylinder I.D.
Check the master cylinder for scores, scratches or nicks.

SERVICE LIMIT: 14.055 mm (0.5533 in)

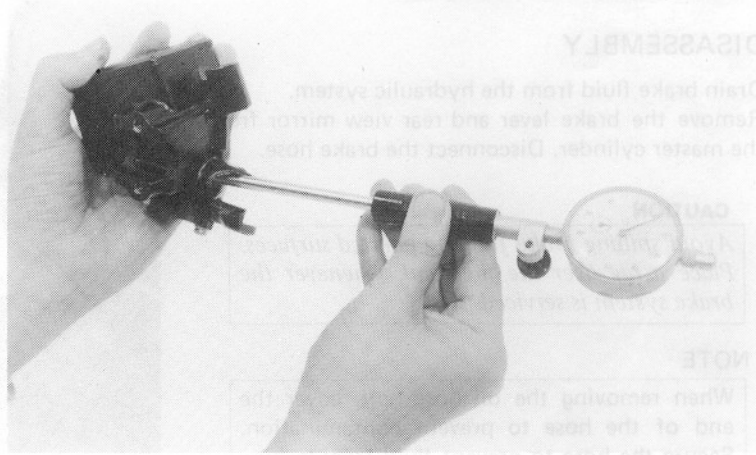

FRONT MASTER PISTON O.D. INSPECTION

Measure the master piston O.D.
SERVICE LIMIT: 13.940 mm (0.5488 in)
Check the primary and secondary cups for damage before assembly.

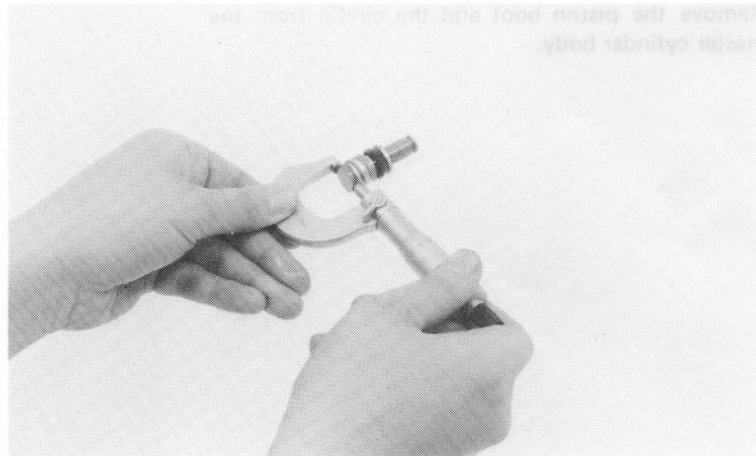

ASSEMBLY

CAUTION

Handle the master cylinder piston, cylinder and spring as a set.

Assemble the master cylinder. Coat all parts with clean brake fluid before assembly. Install the spring and primary cup together.

Dip the piston cup in brake fluid before assembly.

CAUTION

When installing the cups, do not allow the lips to turn inside out. Be certain the circlip is seated firmly in the groove.

Install the piston, clip and boot.

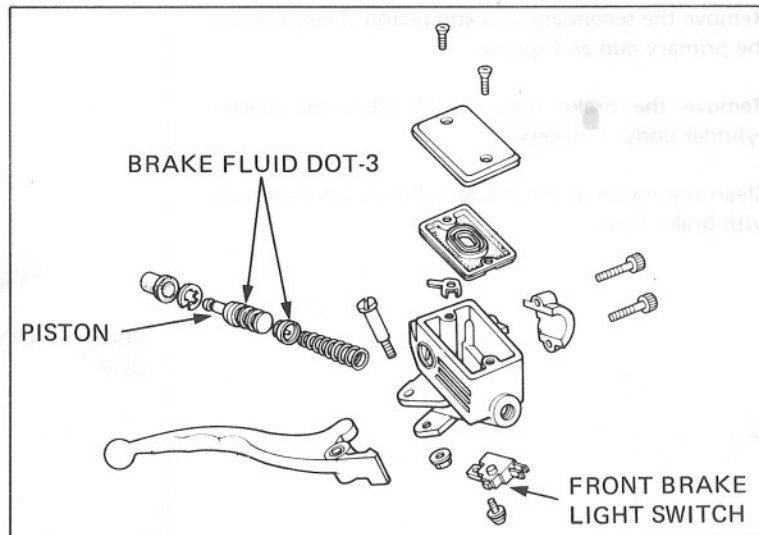



Place the master cylinder on the handlebar and install the holder with "UP mark" facing up and the two mounting bolts. Tighten the top bolt first. Install the oil hose with the bolt and its two sealing washers.

Install the brake lever.

Fill the reservoir to the upper level and bleed the brake system according to page 17-4.



SEALING
WASHERS

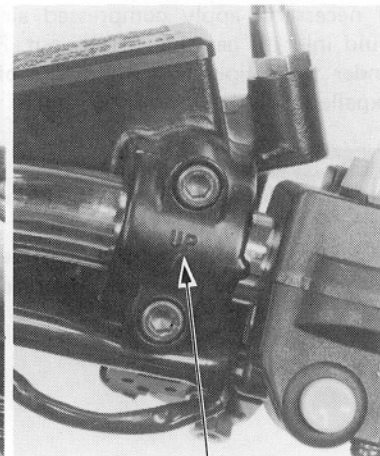

UP MARK

FRONT BRAKE CALIPER

REMOVAL

Place a clean container under the caliper and disconnect the brake hose from the caliper.

CAUTION

Avoid spilling brake fluid on painted surfaces.

Remove the caliper bolt and caliper.

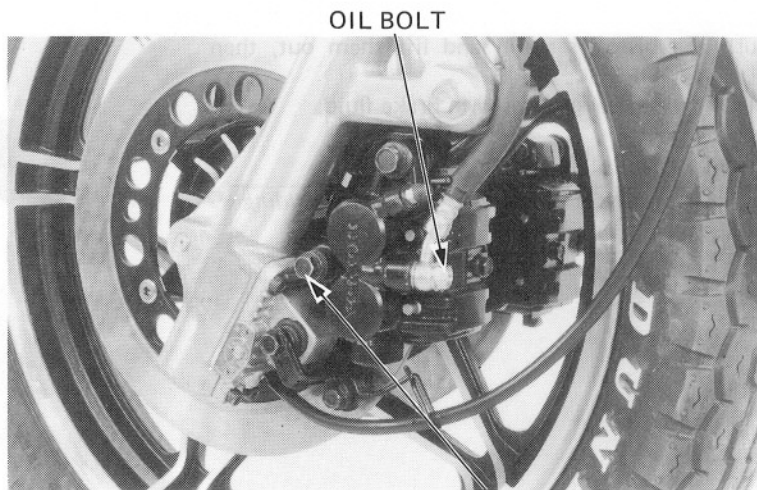

OIL BOLT

CALIPER BOLT

DISASSEMBLY

Remove the pads and pad spring.

Remove the caliper pivot collar and boots.

Remove the pistons from the caliper.

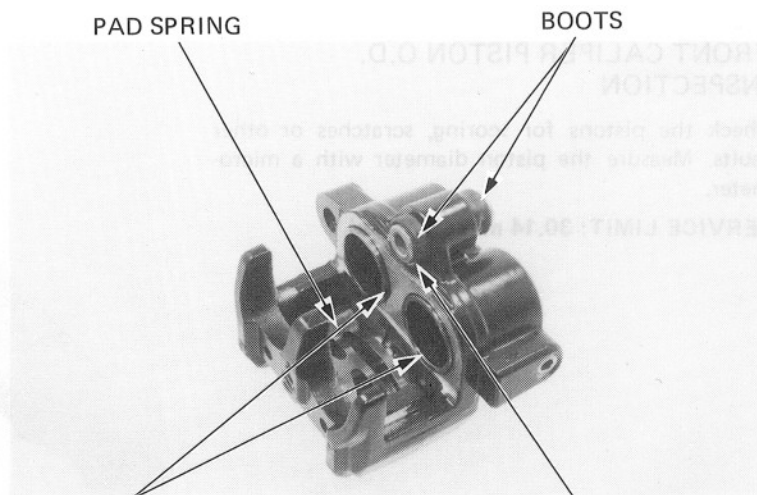

PAD SPRING

BOOTS

PISTON

PIVOT COLLAR



HYDRAULIC BRAKES

If necessary, apply compressed air to the caliper fluid inlet to get the pistons out. Place a shop rag under the caliper to cushion the piston when it is expelled. Use the air in short spurts.

WARNING

Do not bring the nozzle too close to the inlet.

Examine the pistons and cylinders for scoring, scratches or other damage and replace if necessary.

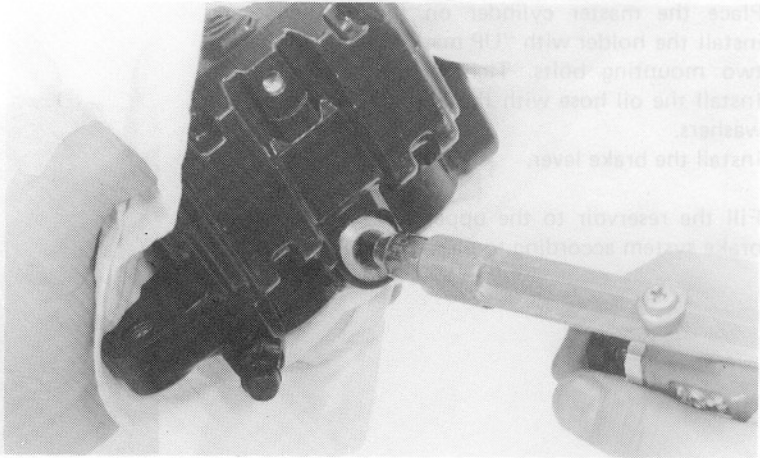

Push the piston seals in and lift them out, then discard them.

Clean the oil seal grooves with brake fluid.

CAUTION

Be careful not to damage the piston sliding surfaces.

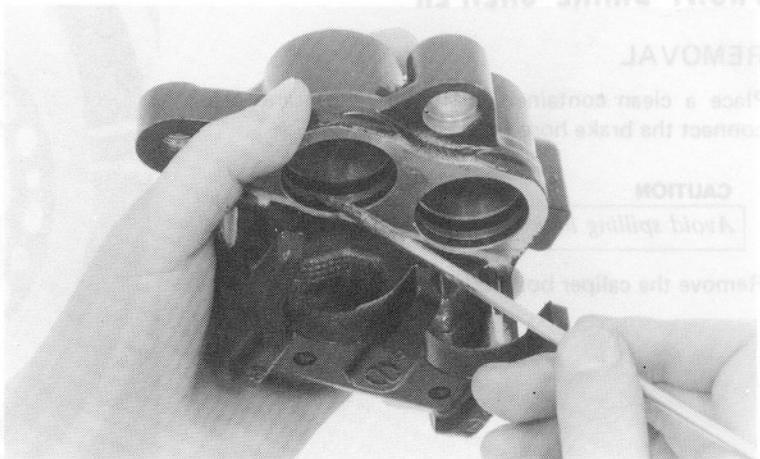

FRONT CALIPER PISTON O.D. INSPECTION

Check the pistons for scoring, scratches or other faults. Measure the piston diameter with a micrometer.

SERVICE LIMIT: 30.14 mm (1.187 in)

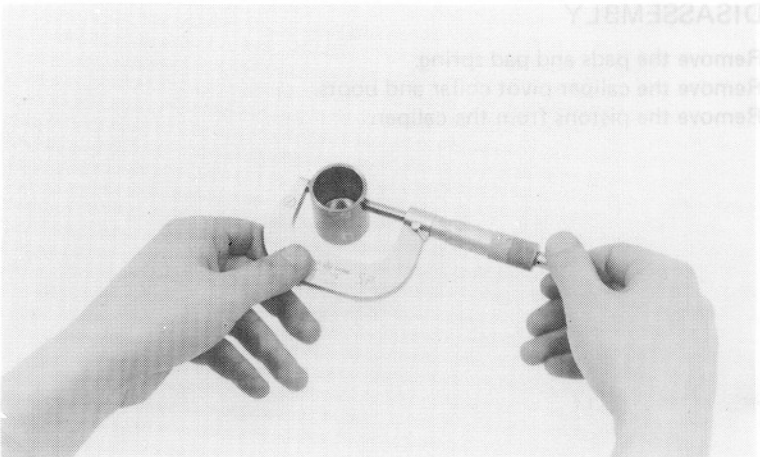



INSPECTION

Check the caliper cylinder for scoring, scratches or other faults. Measure the caliper cylinder bore.

SERVICE LIMIT: 30.29 mm (1.193 in)

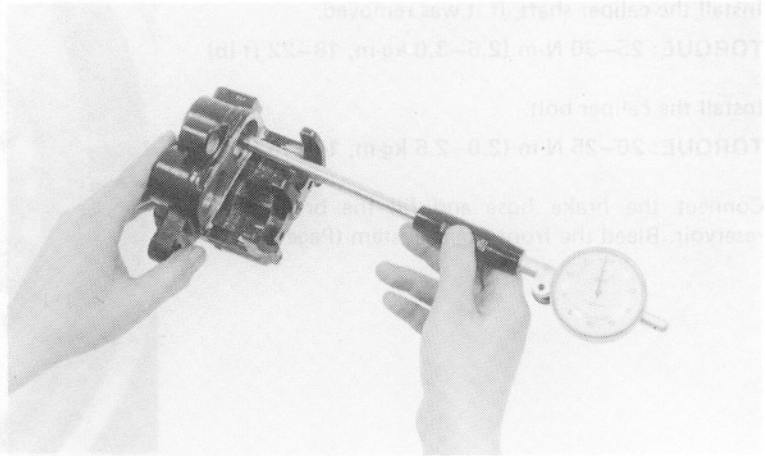

ASSEMBLY

If the piston boots are hardened or deteriorated, replace them with new ones.

The piston seals must be replaced with new ones whenever they are removed. Coat the seals with silicone grease or brake fluid before assembly.

Install the pistons with the dished ends toward the pads. Then install the piston boots.

Install the collar boots and collar making sure that the boots are seated in the collar and caliper grooves properly.

Install the pad spring and pads.

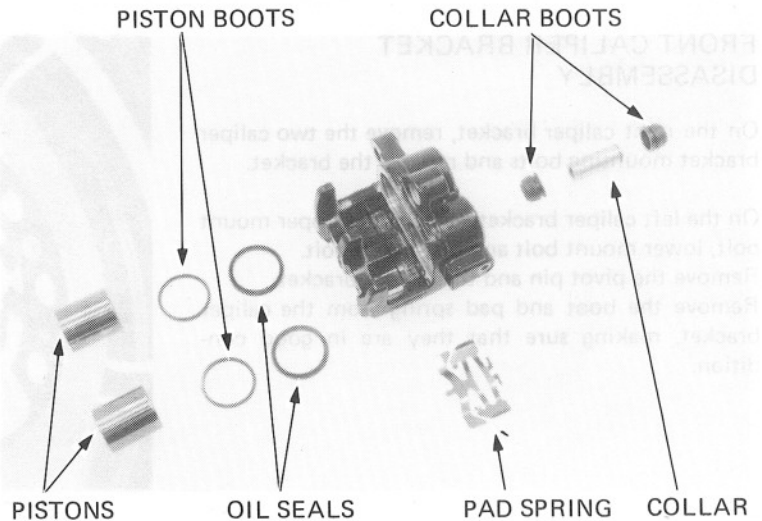

INSTALLATION

Install the pad spring on the caliper bracket as shown.

Inspect the condition of the caliper pivot bolt boot. Apply silicone grease or brake fluid to the caliper pivot bolt.

Install the caliper assembly over the brake disc so that the disc is positioned between the pads.

CAUTION

Be careful not to damage the pads.

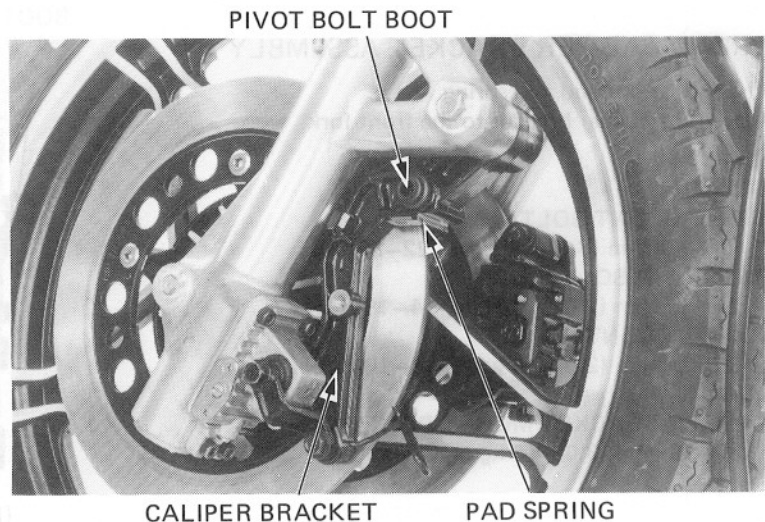

HYDRAULIC BRAKES



HONDA
CB1000C

Install the caliper shaft, if it was removed.

TORQUE: 25–30 N·m (2.5–3.0 kg·m, 18–22 ft·lb)

Install the caliper bolt.

TORQUE: 20–25 N·m (2.0–2.5 kg·m, 14–18 ft·lb)

Connect the brake hose and fill the brake fluid reservoir. Bleed the front brake system (Page 17-4).

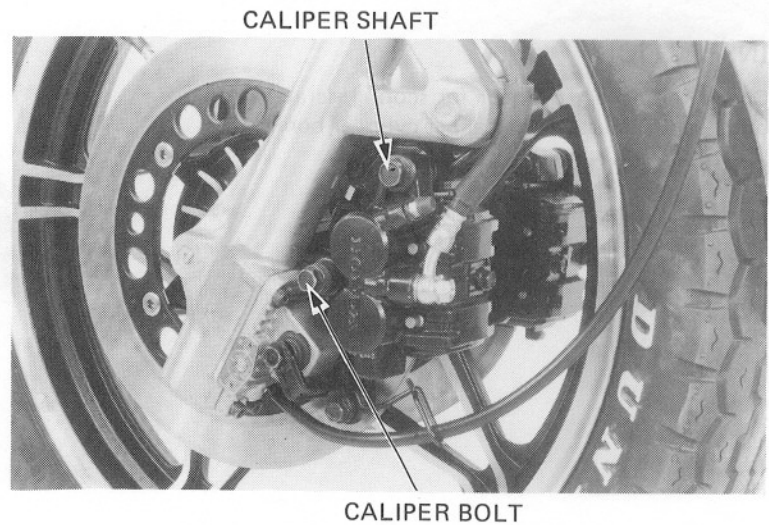

FRONT CALIPER BRACKET DISASSEMBLY

On the right caliper bracket, remove the two caliper bracket mounting bolts and remove the bracket.

On the left caliper bracket, remove the upper mount bolt, lower mount bolt and piston pin bolt. Remove the pivot pin and the caliper bracket. Remove the boot and pad spring from the caliper bracket, making sure that they are in good condition.

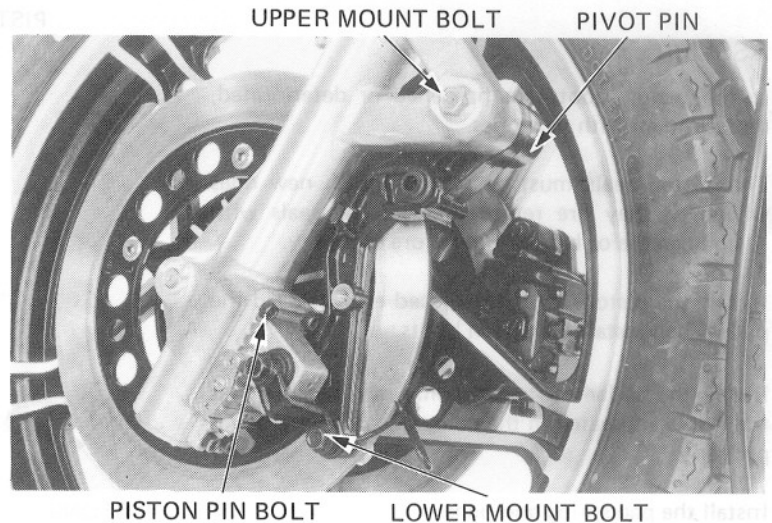

FRONT CALIPER BRACKET ASSEMBLY

Install the boot and pad spring.
Attach the caliper bracket to the front fork.

(LEFT)

TORQUE:

UPPER MOUNT BOLT:

30–40 N·m (3.0–4.0 kg·m, 22–29 ft·lb)

PISTON PIN BOLT:

20–25 N·m (2.0–2.5 kg·m, 14–18 ft·lb)

LOWER MOUNT BOLT:

20–25 N·m (2.0–2.5 kg·m, 14–18 ft·lb)

(RIGHT)

CALIPER BRACKET MOUNT BOLT:

30–40 N·m (3.0–4.0 kg·m, 22–29 ft·lb)

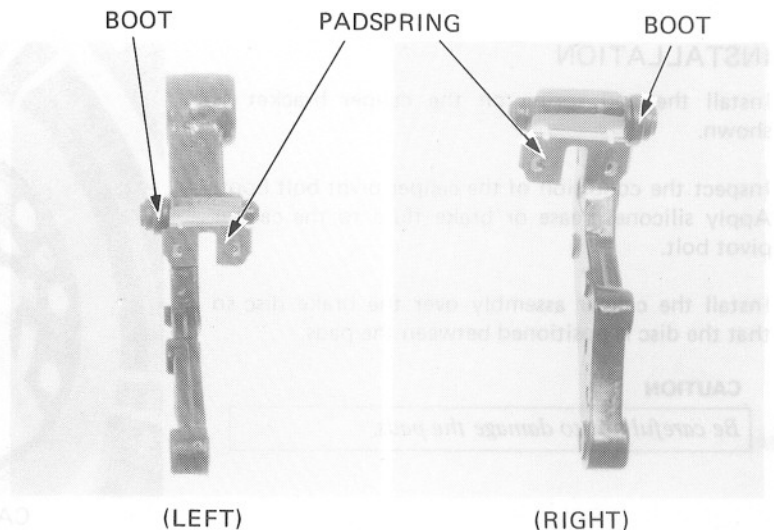



REAR MASTER CYLINDER

REMOVAL

Remove the following:

- frame right side cover.
- brake pedal.
- right muffler.
- master cylinder setting bolts.
- brake pedal bracket.
- cotter pin and joint pin.

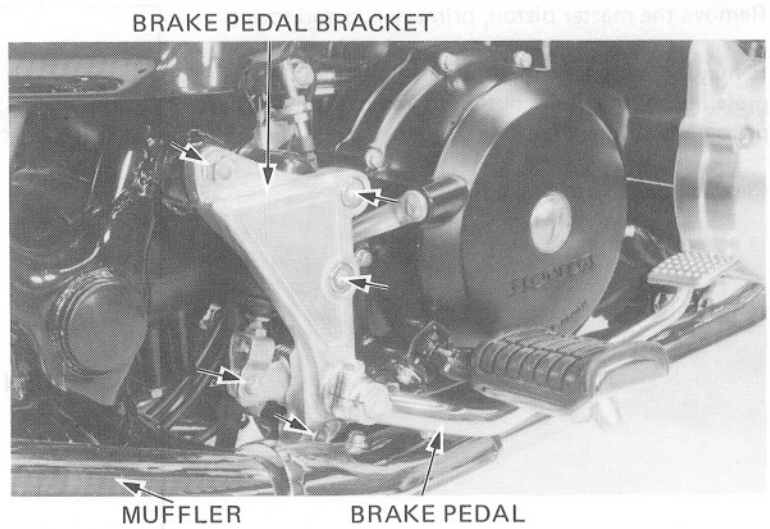

Place a clean drip pan under the brake line.
Disconnect the brake line on the back of the master cylinder.

CAUTION

Avoid spilling brake fluid on painted surfaces.

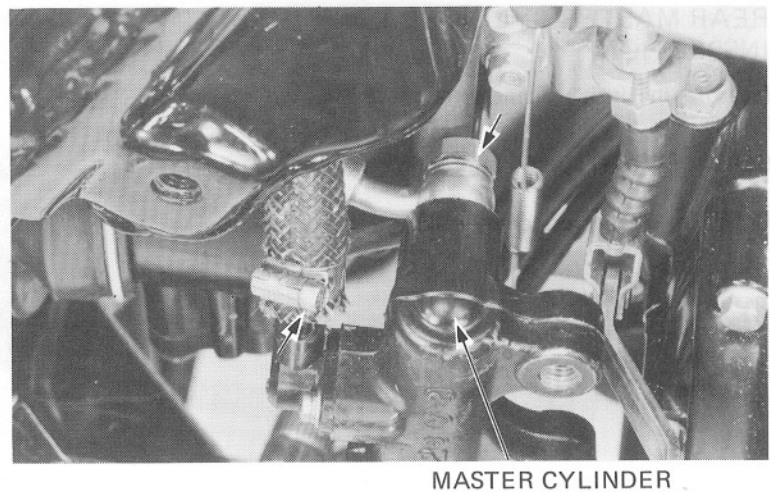

DISASSEMBLY

Remove the rubber cover.
Remove the circlip and push rod from the master cylinder body.

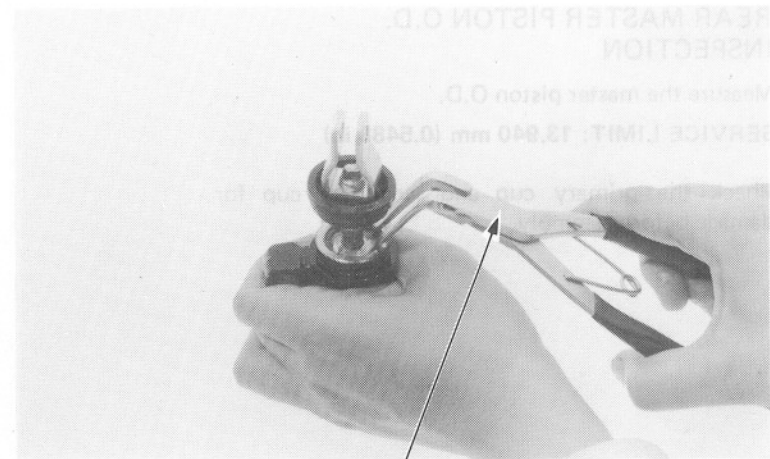



HYDRAULIC BRAKES

Remove the master piston, primary cup and spring.

It may be necessary to apply a small amount of air pressure to the fluid outlet to remove the master piston and primary cup.

Clean all parts with brake fluid.

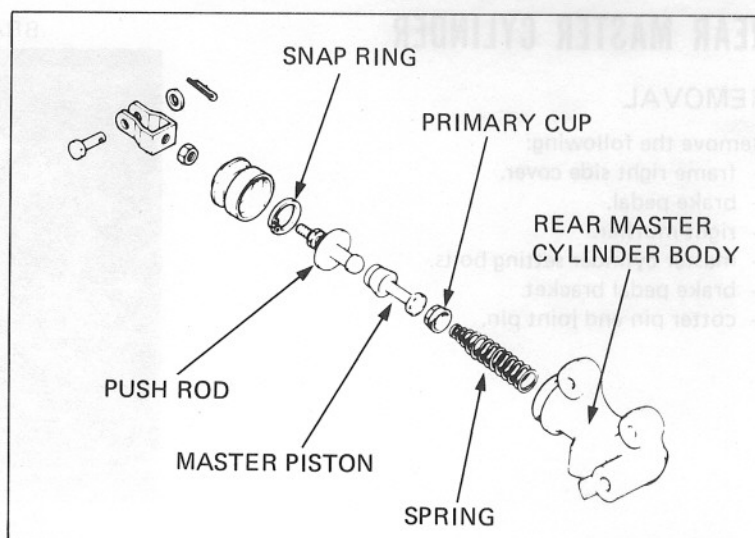

REAR MASTER CYLINDER I.D. INSPECTION

Measure the inside diameter of the master cylinder bore.

SERVICE LIMIT: 14.06 mm (0.553 in)

Check for scores, scratches or nicks.

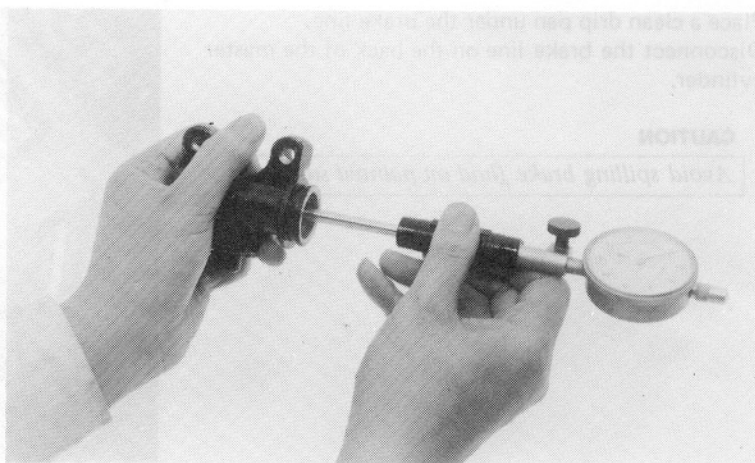

REAR MASTER PISTON O.D. INSPECTION

Measure the master piston O.D.

SERVICE LIMIT: 13.940 mm (0.5488 in)

Check the primary cup and secondary cup for damage before assembly.

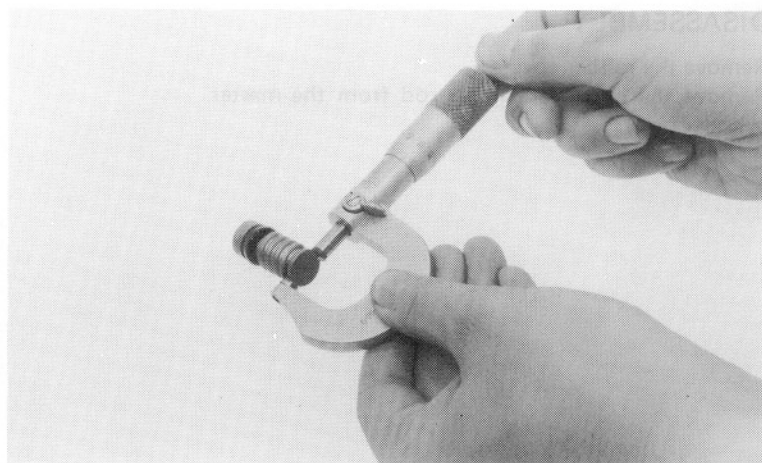



REAR MASTER CYLINDER ASSEMBLY

CAUTION

Handle the master cylinder piston, cylinder and spring as a set.

Assemble the master cylinder.
Coat all parts with clean brake fluid.

Dip the piston cup in brake fluid before assembly.

CAUTION

When installing the cups, do not allow the lips to turn inside out. Be certain the snap ring is seated firmly in the groove.

Install the following:

- primary cup and piston.
- push rod and circlip.
- boot, nut and rod eye.

Install the master cylinder on the master cylinder bracket.

TORQUE: 30–40 N·m (3.0–4.0 kg·m, 22–29 ft·lb)

Connect the brake hose and brake rod.

Install the right muffler.

Bleed the brake hydraulic system after assembly (Page 17-4).

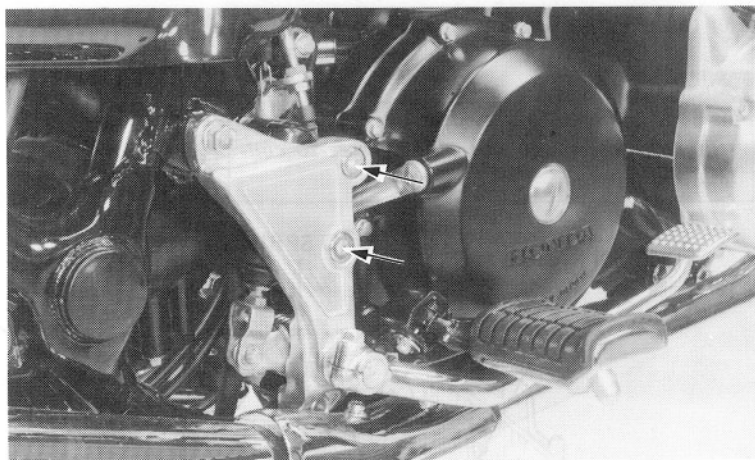
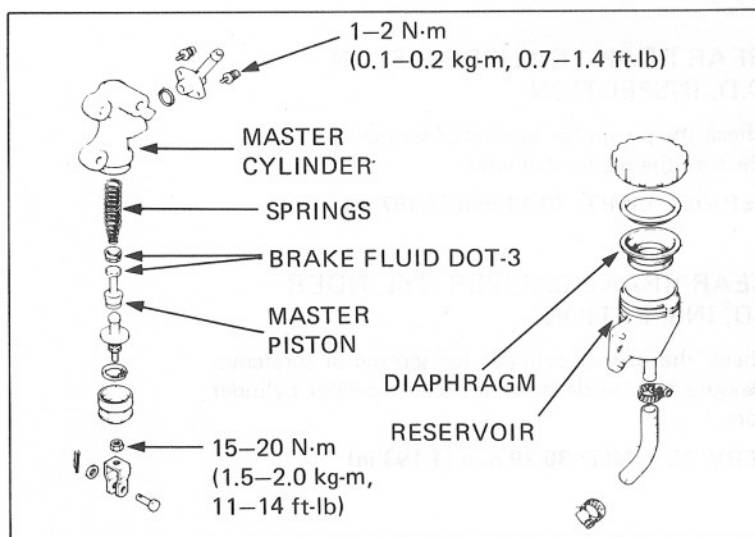

REAR BRAKE CALIPER

REMOVAL

Drain the brake hydraulic system (Page 17-3).
Disconnect the brake hose and remove the dust cover.

NOTE

Avoid spilling brake fluid on painted surfaces and the brake surfaces.

Remove the caliper bolt and caliper shaft.

DISASSEMBLY

Refer to Front Brake Caliper (Page 17-11).

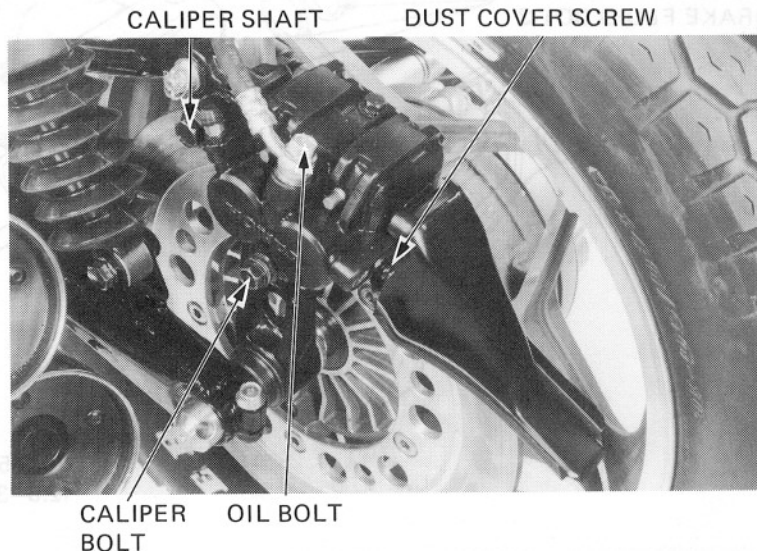



HYDRAULIC BRAKES

REAR BRAKE CALIPER PISTON O.D. INSPECTION

Check the piston for scoring or scratches.
Measure the piston diameter.

SERVICE LIMIT: 30.14 mm (1.187 in)

REAR BRAKE CALIPER CYLINDER I.D. INSPECTION

Check the caliper cylinder for scoring or scratches.
Measure the inside diameter of the caliper cylinder bore.

SERVICE LIMIT: 30.29 mm (1.193 in)

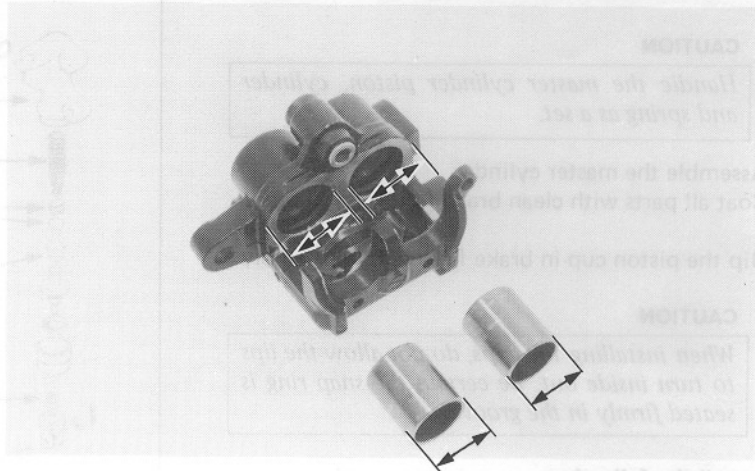

ASSEMBLY

Refer to the Front Brake Caliper (Page 17-13).

WARNING

A contaminated brake disc or pad reduces stopping power. Do not allow grease to contact pad faces.

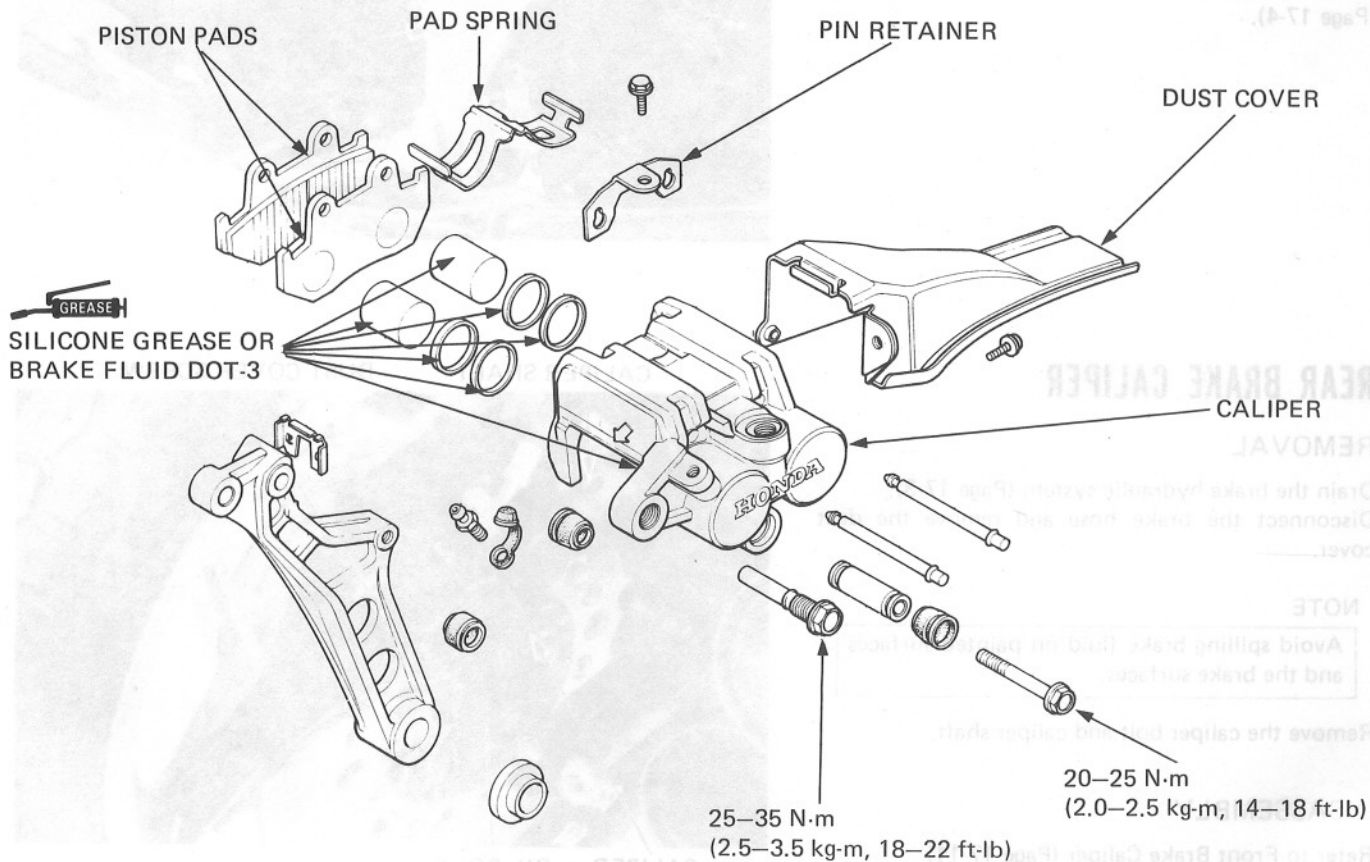



**REAR CALIPER BRACKET
DISASSEMBLY**

Remove the rear brake caliper (Page 17-17).
Remove the axle nut and rear axle.
Remove the bracket cotter pin and nut.
Disconnect the brake torque link from the rear
brake caliper bracket.
Remove the rear caliper bracket.

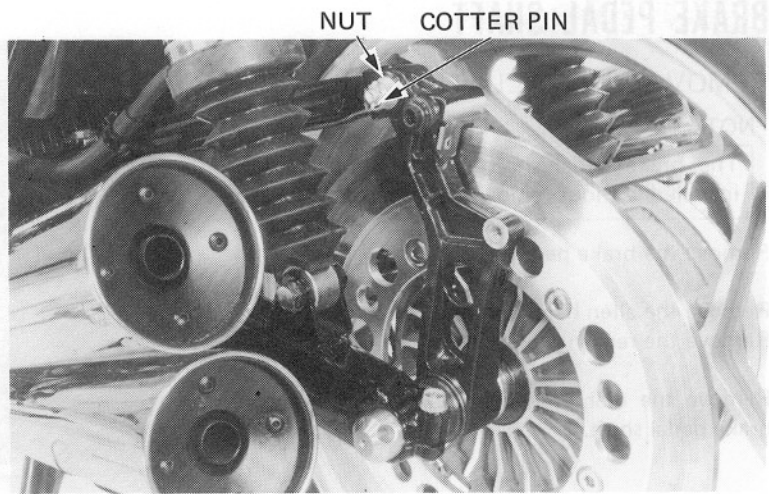

REAR CALIPER BRACKET ASSEMBLY

Install the boot and pad spring.

Install the rear caliper bracket in the reverse order
of removal.

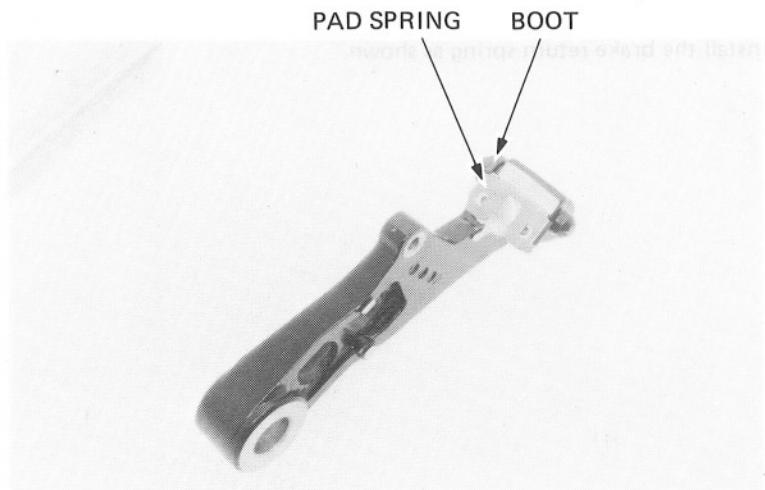

BRAKE PEDAL SHAFT

REMOVAL/INSTALLATION

NOTE

The brake pedal shaft can be removed and installed without removing the muffler.

Remove the brake pedal.

Remove the allen head bolt and rod pin.
Remove the rear master cylinder.

Remove the rear brakelight switch spring and rear brake pedal shaft.

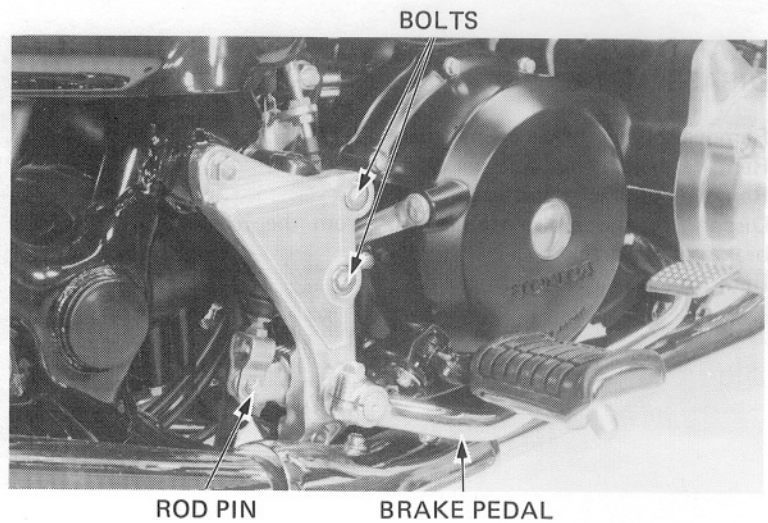

Install the brake return spring as shown.

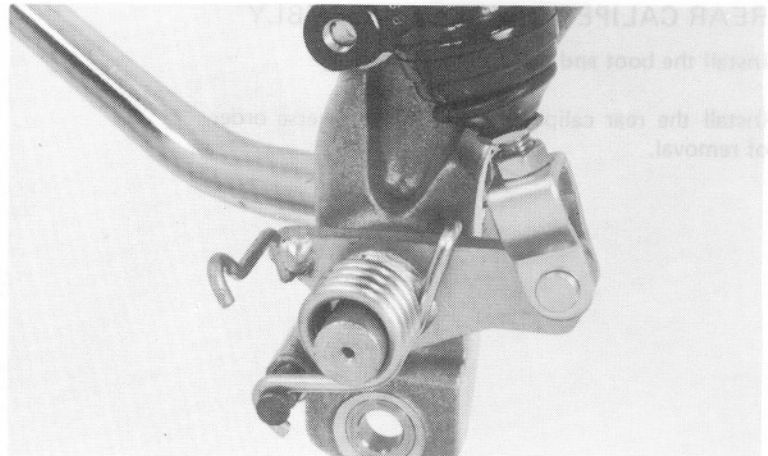

Align the punch marks and install the rear brake pedal.

