



SERVICE INFORMATION	15- 1
TROUBLESHOOTING	15- 1
REAR WHEEL	15- 2
SHOCK ABSORBER	15- 8
SWING ARM	15-12

SERVICE INFORMATION

GENERAL

- The rear wheel uses a tubeless tire. For tubeless tire repairs, refer to the tubeless tire manual.
- Never ride on the rim or try to bend wheel.
- Avoid damaging the cast wheel.

SPECIFICATIONS

		STANDARD	SERVICE LIMIT
Axle runout		_____	0.2 mm (0.01 in)
Rear wheel rim runout	Radial	_____	2.0 mm (0.08 in)
	Axial	_____	2.0 mm (0.08 in)
Shock absorber air pressure		0-400 kPa (0-4.0 kg/cm ² , 0-57 psi)	_____
Shock absorber fluid capacity		365 cc (12.5 ozs)	_____

TORQUE VALUES

Rear brake disc	30-35 N·m (3.0-3.5 kg-m, 22-25 ft-lb)
Rear axle nut	80-100 N·m (8.0-10.0 kg-m, 58-72 ft-lb)
Rear axle pinch bolt	24-29 N·m (2.4-2.9 kg-m, 17-21 ft-lb)
Rear shock absorber	30-40 N·m (3.0-4.0 kg-m, 22-29 ft-lb)
Rear brake torque link	18-25 N·m (1.8-2.5 kg-m, 13-18 ft-lb)
Swing arm pivot bolt	50-70 N·m (5.0-7.0 kg-m, 36-51 ft-lb)
Swing arm pivot adjusting bolt	16-20 N·m (1.6-2.0 kg-m, 12-14 ft-lb)
Swing arm pivot bolt lock nut	50-70 N·m (5.0-7.0 kg-m, 36-51 ft-lb)
3-way joint lock nut	19-23 N·m (1.9-2.3 kg-m, 14-17 ft-lb)
Air hose (to 3-way joint)	15-20 N·m (1.5-2.0 kg-m, 11-14 ft-lb)
(to shock absorber)	4-7 N·m (0.4-0.7 kg-m, 3-5 ft-lb)
Air hose connector	8-12 N·m (0.8-1.2 kg-m, 6-9 ft-lb)
Air valve	4-7 N·m (0.4-0.7 kg-m, 3-5 ft-lb)

TOOLS

Common	
Driver	07749-0010000
Attachment, 42 x 47 mm	07746-0010300
Attachment, 52 x 55 mm	07746-0010400
Pilot, 20 mm	07746-0040500
Pilot, 25 mm	07746-0040600
Special	
Fork seal driver	07947-3710100
Swingarm pivot lock nut wrench	07908-4690001 or KS-HBA-08-469 (U.S.A. only)
Hex wrench 10 mm	07917-3710000 (Commercially available)

TROUBLESHOOTING

Oscillation

1. Distorted rim.
2. Loose wheel bearing.
3. Loose or bent spokes.
4. Faulty tire.
5. Loose axle.
6. Tire pressure incorrect.
7. Swing arm bushing worn.

Soft Suspension

1. Weak spring.
2. Insufficient fluid in shock absorber.
3. Shock absorber air pressure incorrect.

Hard Suspension

1. Incorrect fluid weight in shock absorber.
2. Bent shock absorber.
3. Shock absorber air pressure incorrect.

Suspension Noise

1. Shock case binding.
2. Loose fasteners.



REAR WHEEL

REMOVAL

Place the motorcycle on its center stand.
Support the rear wheel so it will not drop when the shock absorber is disconnected.
Remove the axle nut.

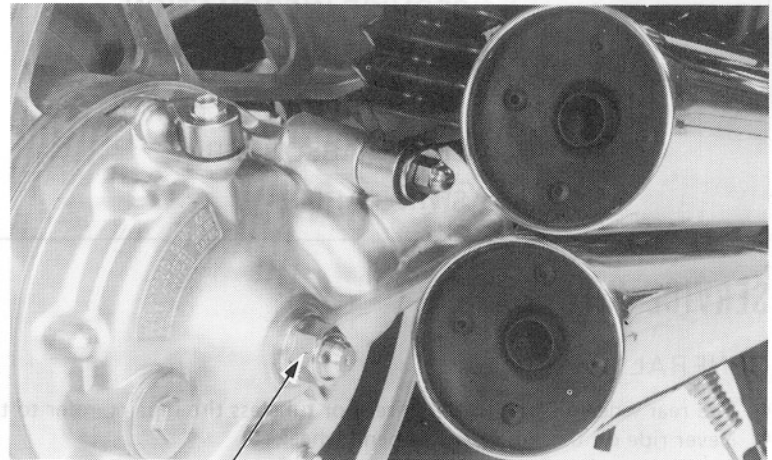

AXLE NUT

Loosen the axle holding bolt. Remove the brake disc dust cover.
Remove the right shock absorber nut and shock absorber from the final drive case.
Pull out the rear axle.

CAUTION

Support the caliper assembly and swingarm before removing the rear axle so that it does not hang from the brake hose. Do not twist the brake hose.

Separate the wheel from the final drive case.
Remove the three final drive case nuts.

DUST COVER

FINAL DRIVE CASE NUTS



AXLE

AXLE HOLDING BOLT

REAR SHOCK ABSORBER

Move the wheel backward and remove the final drive case.

CAUTION

Do not lay the final drive case over. The gear oil may flow out of the breather.

Remove the wheel.

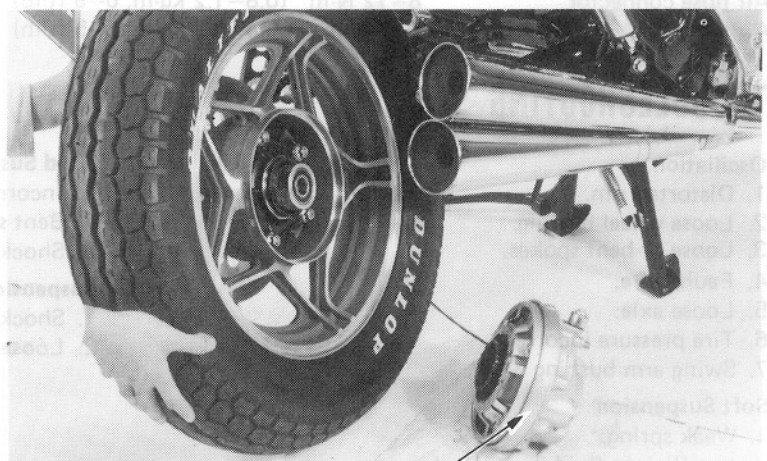

FINAL DRIVE CASE



DISASSEMBLY

Remove the final driven flange.

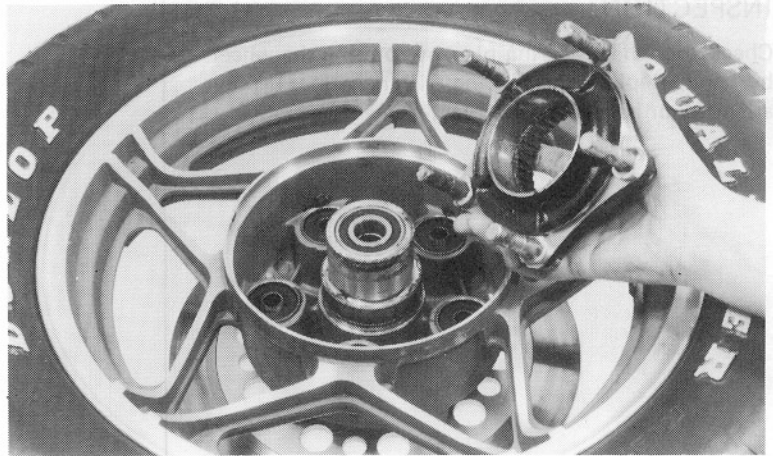

Remove the brake disc socket bolts and disc.

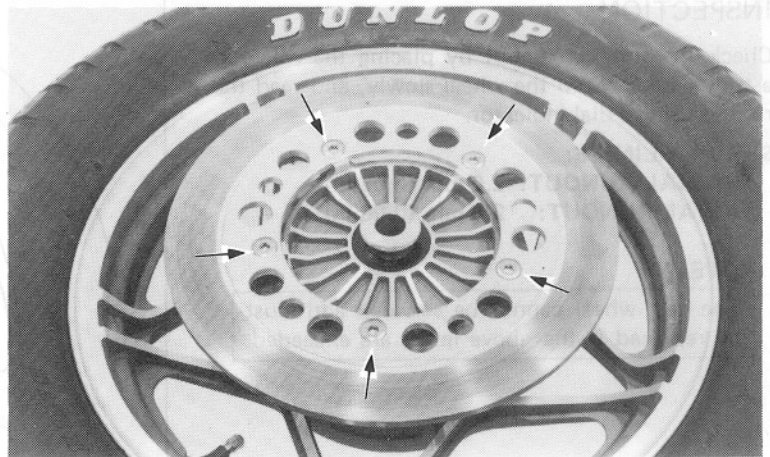

AXLE INSPECTION

Set the axle in V blocks and read the axle runout. The actual axle runout is 1/2 of the total indicator reading.

SERVICE LIMIT: 0.2 mm (0.01 in)

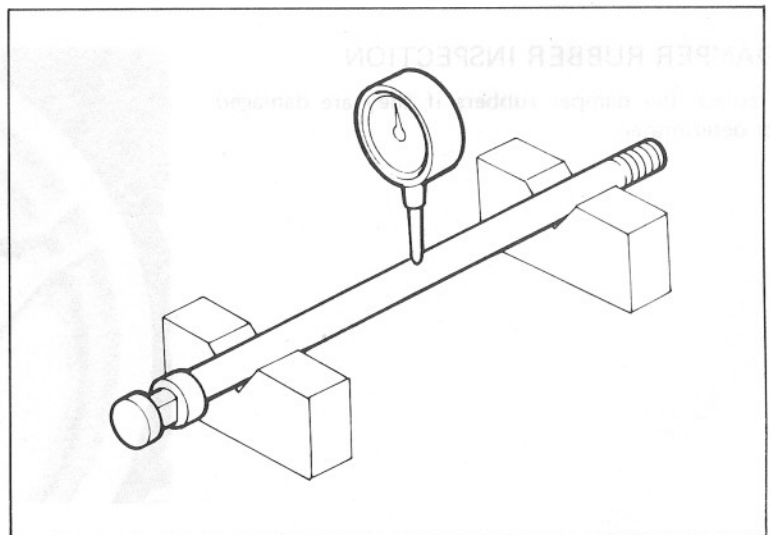



REAR WHEEL/SUSPENSION

REAR WHEEL BEARING PLAY INSPECTION

Check the wheel bearing play by rotating the wheel by hand. Replace the bearing with new ones if they are noisy or have excessive play.

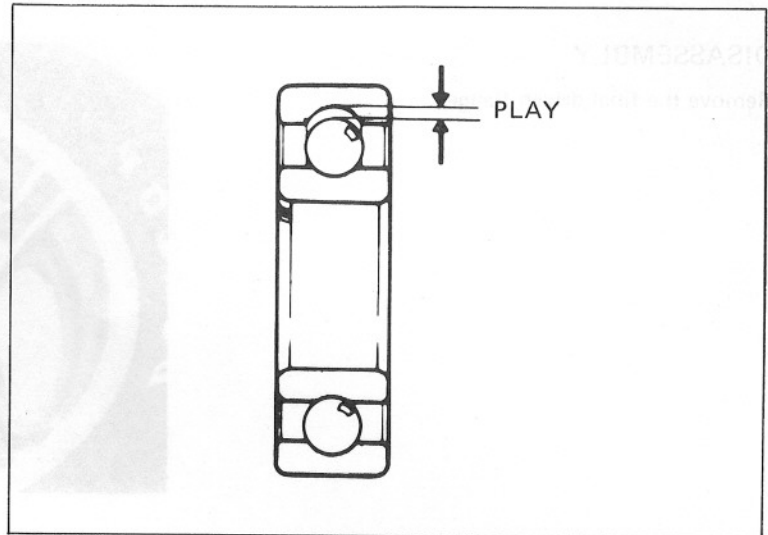

REAR WHEEL RIM RUNOUT INSPECTION

Check the rim for runout by placing the wheel in a truing stand. Spin the wheel slowly, and read the runout using a dial indicator.

SERVICE LIMITS:

RADIAL RUNOUT: 2.0 mm (0.08 in)

AXIAL RUNOUT: 2.0 mm (0.08 in)

NOTE

The cast wheel cannot be serviced and must be replaced if the above limits are exceeded.

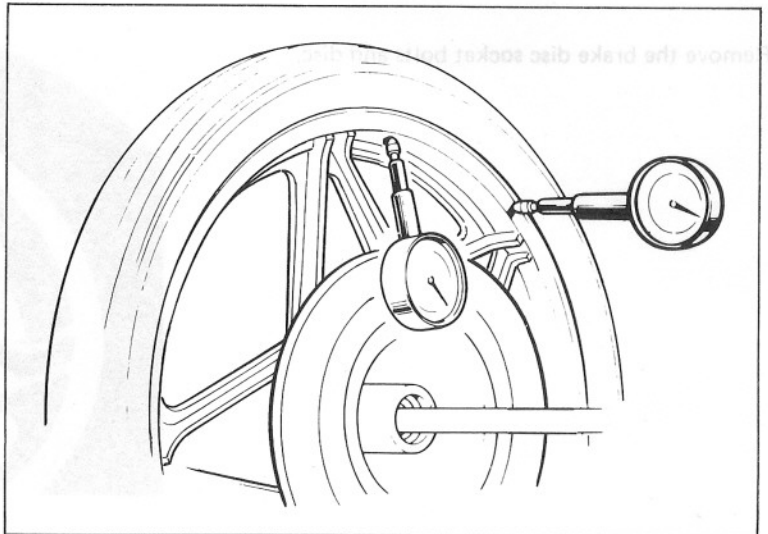

DAMPER RUBBER INSPECTION

Replace the damper rubbers if they are damaged or deteriorated.

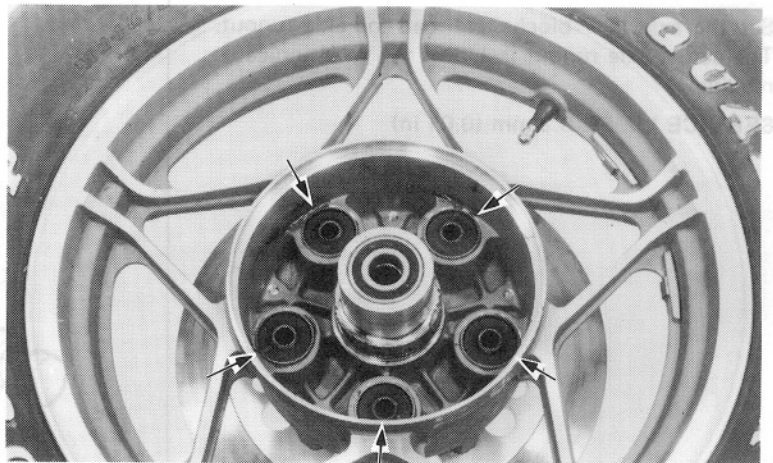



ASSEMBLY

NOTE

The rear wheel uses a tubeless tire. For tubeless tire repairs, refer to Tubeless Tire manual.

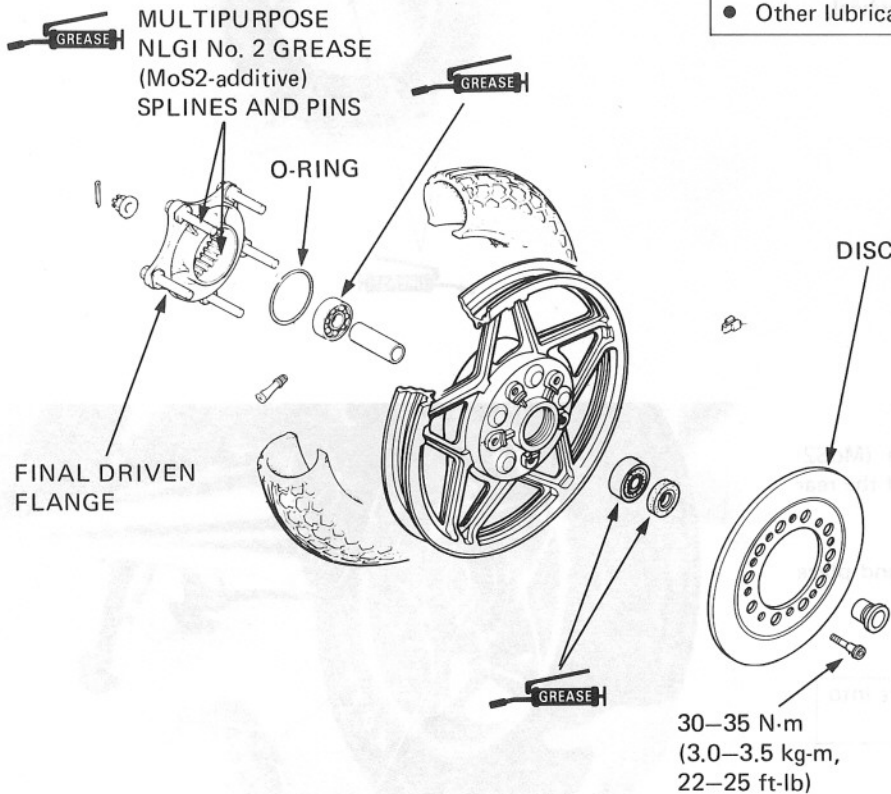

NOTE

Use lithium-based multipurpose grease with MoS2-additive as follows:

- Molykote BR2-S manufactured by Dow Corning, U.S.A.
- Multipurpose M-2 manufactured by Mitsubishi Oil, Japan.
- Other lubricants of equivalent quality.

Apply multipurpose grease to the holes of the rubber dampers.

Press the distance collar into place from the left side.

Drive in the right ball bearing first, then the left ball bearing.

CAUTION

Drive the bearings in squarely. Install the bearings with the sealed end facing out, making sure they are fully seated.

Install the brake disc and socket bolts.

TORQUE: 30-35 N·m (3.0-3.5 kg-m, 22-25 ft-lb)

Clean the brake disc with a high quality degreasing agent.

CAUTION

When installing the brake disc, apply grease to the bolt threads.

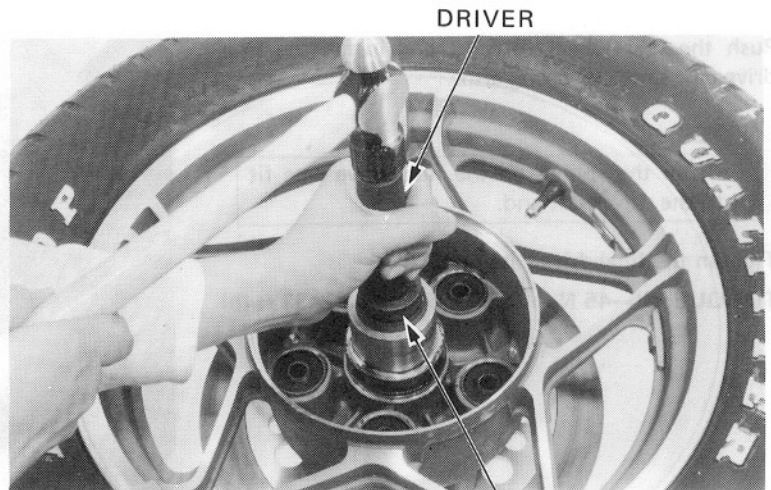

DRIVER, 42 x 47 mm
PILOT, 20 mm



REAR WHEEL/SUSPENSION

Install the fixing bolts as shown.
Install the new nuts.

Apply Multipurpose NLGI No. 2 Grease (MoS2-additive) to the fixing bolts and inside of the final driven flange.

Install the final driven flange onto the rear wheel.

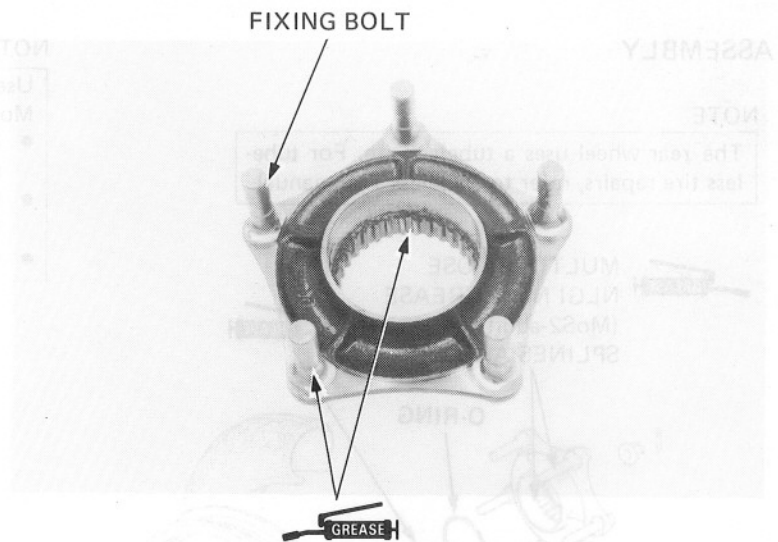

INSTALLATION

Apply Multipurpose NLGI No. 2 Grease (MoS2-additive) to the final driven flange spline of the rear wheel and ring gear.

Set the rear wheel under the rear fender and place the final drive case into the rear wheel.

NOTE

Be sure the splines on the wheel hub fit into the final drive case.



**LITHIUM BASED
MULTIPURPOSE
GREASE**

Push the rear wheel forward and install the final drive case onto the swing arm.

NOTE

Be sure the splines on the final drive case fit into the driveshaft end.

Tighten the final drive case nuts.

TORQUE: 35-45 N·m (3.5-4.5 kg-m, 25-33 ft-lb)





Install the rear axle through the swing arm, washer and brake caliper bracket.

Install the right rear shock absorber to the final drive case and tighten the cap nut.

TORQUE: 30–40 N·m (3.0–4.0 kg·m, 22–29 ft·lb)

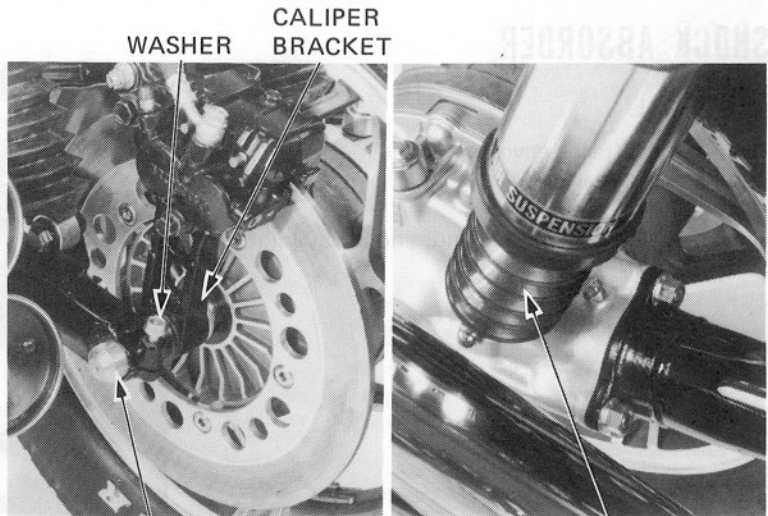

REAR AXLE

REAR SHOCK ABSORBER

Install and tighten the axle nut.

TORQUE: 85–105 N·m
(8.5–10.5 kg·m, 61–76 ft·lb)

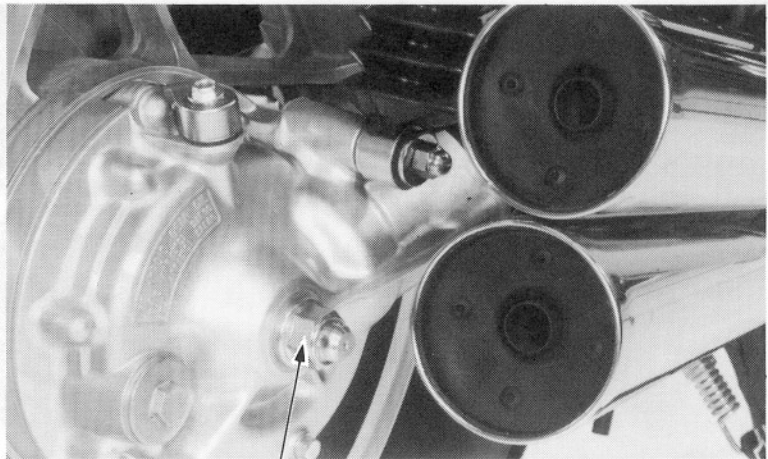

AXLE NUT

Tighten the axle holding bolt.

TORQUE: 24–29 N·m (2.4–2.9 kg·m, 17–21 ft·lb)

Install the dust cover.

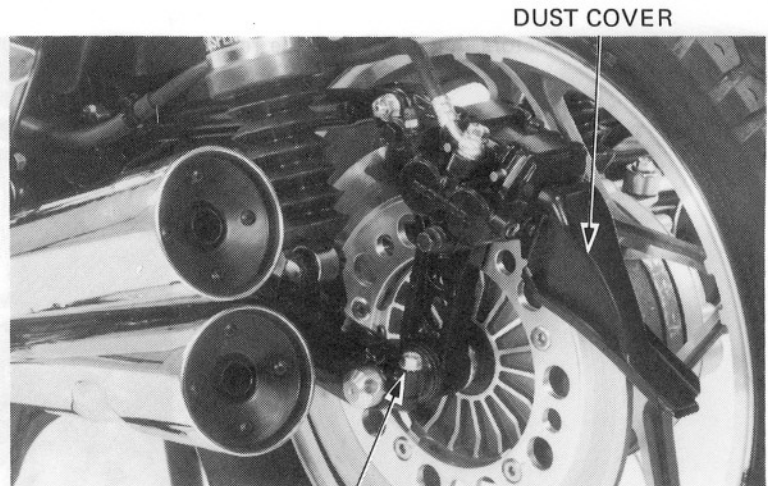

AXLE HOLDING BOLT



REAR WHEEL/SUSPENSION

SHOCK ABSORBER

REMOVAL

Remove the left side cover and seat.
Remove the air valve cap.

Remove the 3-way joint lock nut and 3-way joint.

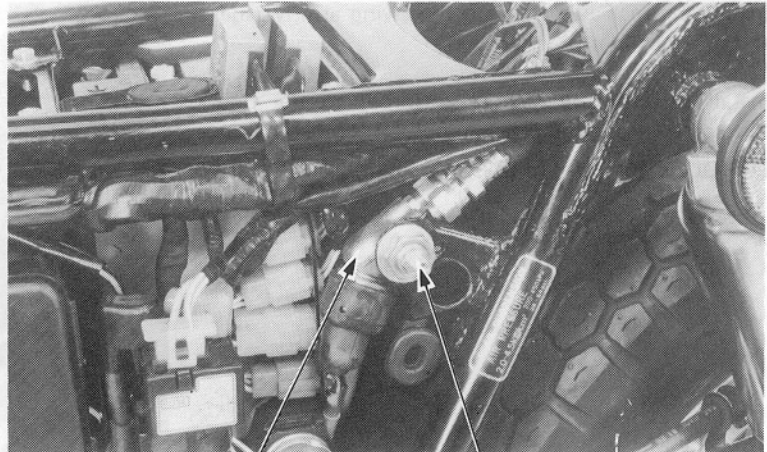

3-WAY JOINT

LOCK NUT

Disconnect the air hoses from the 3-way joint.

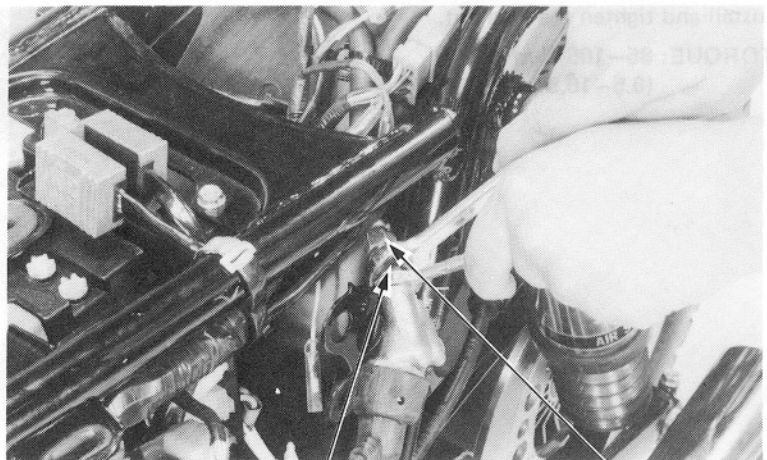

CONNECTOR

AIR HOSE

Remove the side reflectors, hand rail and the rear shock absorber.

REFLECTOR

HAND RAIL

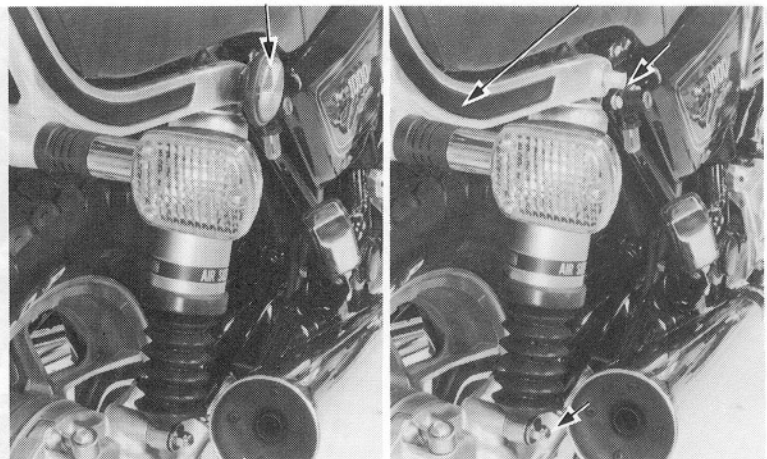



DISASSEMBLY

Disconnect the air hose and remove the boot.
Remove the circlip and back-up plate "B".
Turn the shock upside down and drain as much oil as possible.

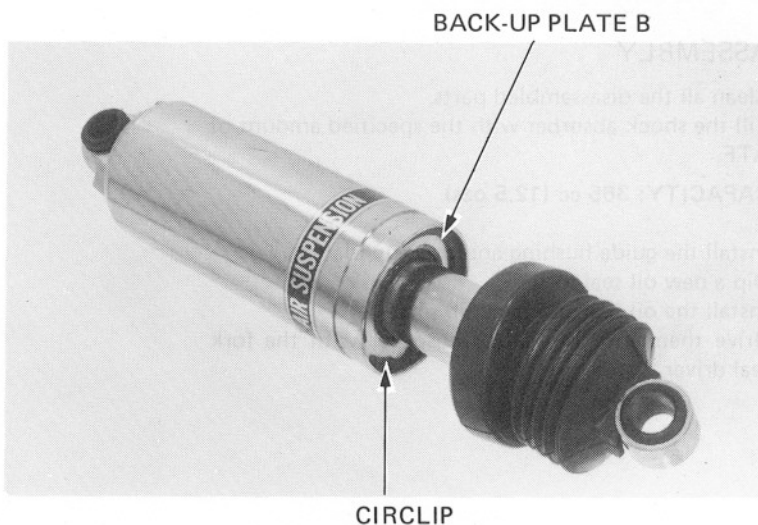

Reconnect the boot to the shock outer.
Place the shock lower mount in a vise with soft jaws. Place a shop towel around the boot area to prevent oil splashing.

WARNING

Do not hold the shock below the seal during the next operation because the seal, back-up plate and the guide bushing will come out with force. Wear eye and face protection.

Remove the oil seal by applying compressed air. The seal may stick, therefore small air spurts may be necessary.
Drain the shock oil.
Remove back-up plate A and the guide bushing.

Check the guide bushing for wear.

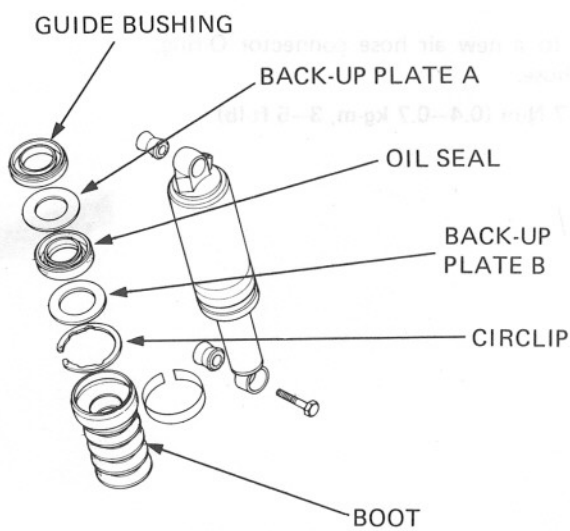
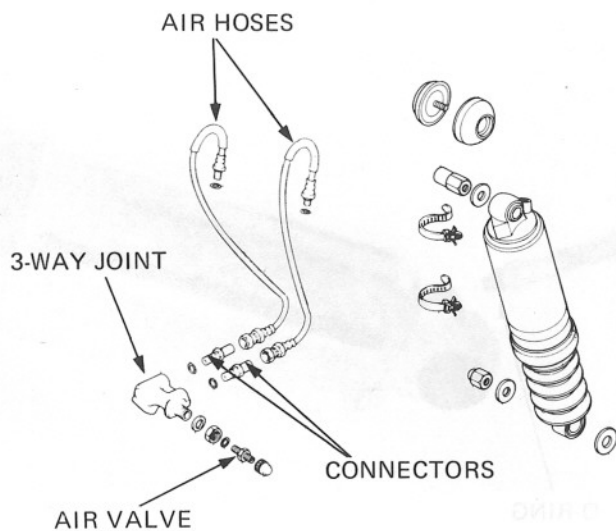
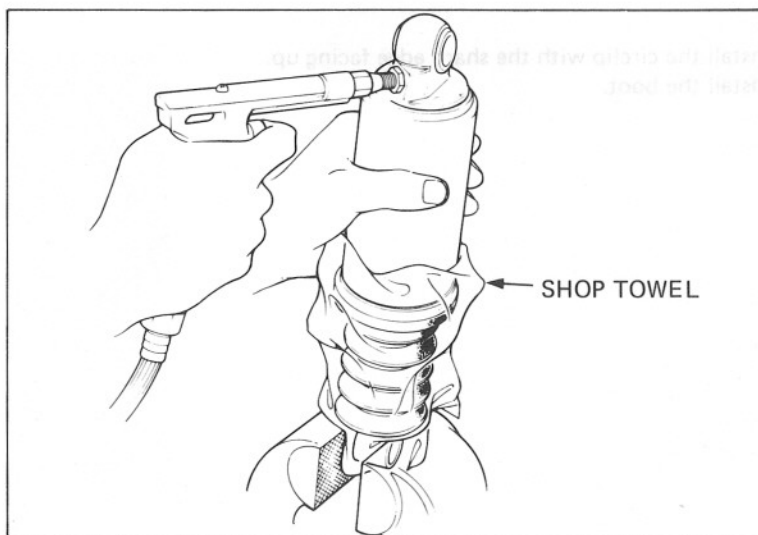



REAR WHEEL/SUSPENSION

FORK SEAL DRIVER
07947-3710100

ASSEMBLY

Clean all the disassembled parts.
Fill the shock absorber with the specified amount of ATF.

CAPACITY: 365 cc (12.5 ozs)

Install the guide bushing and back-up plate A.
Dip a new oil seal in ATF.
Install the oil seal and back up plate.
Drive them into the shock absorber with the fork seal driver.

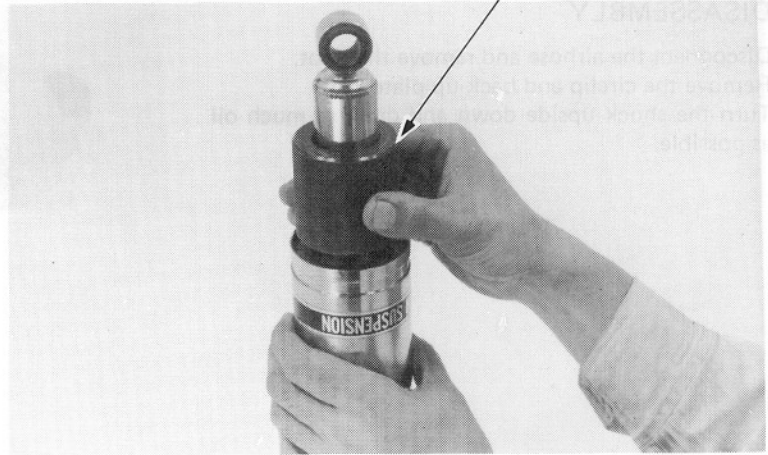

Install the circlip with the sharp edge facing up.
Install the boot.

CIRCLIP PLIERS
07914-3230001

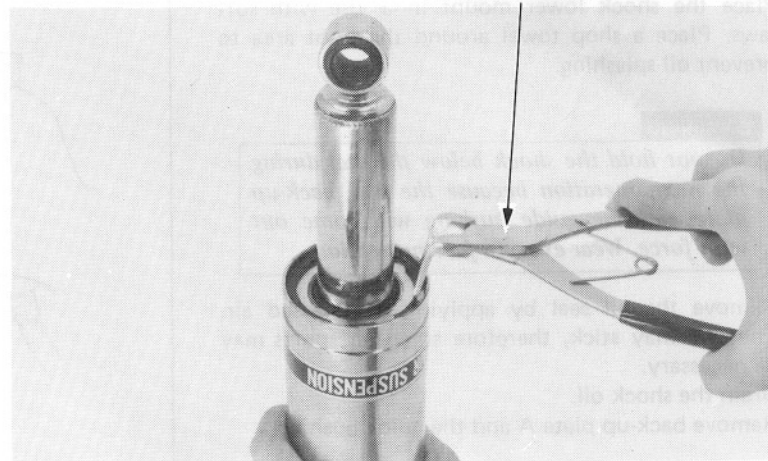

Apply grease to a new air hose connector O-ring.
Install the air hose.

TORQUE: 4-7 N·m (0.4-0.7 kg·m, 3-5 ft·lb)

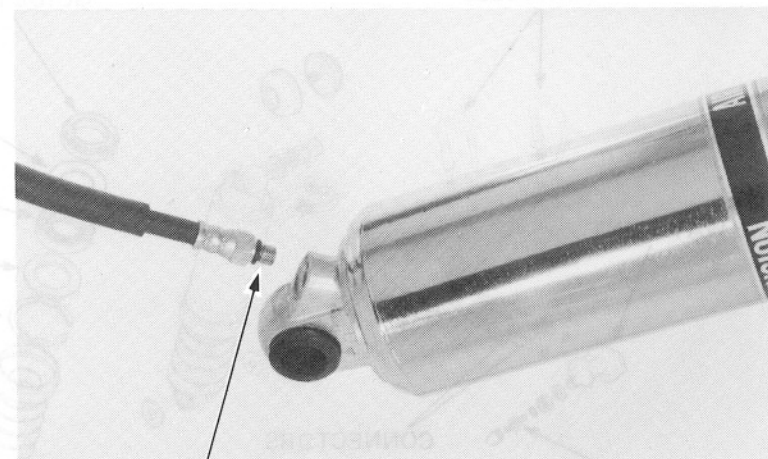

O-RING



INSTALLATION

Apply grease to new O-rings.

Install the connectors and air valve.

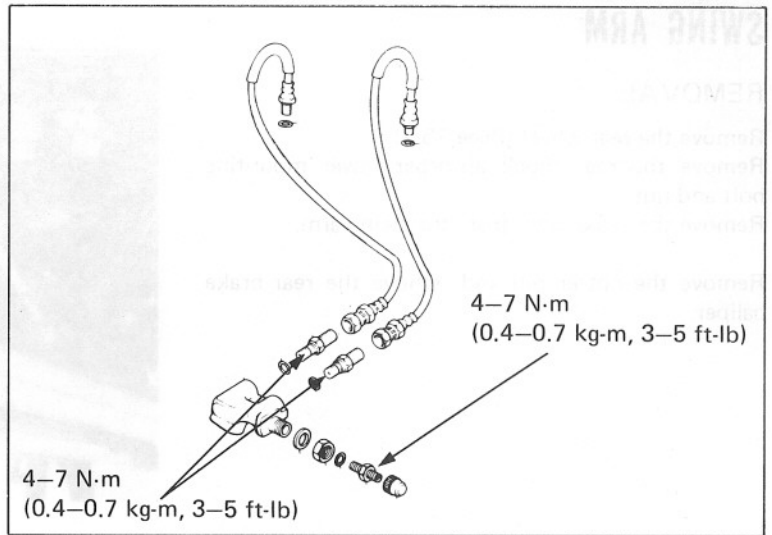

Install the shock absorber.

TORQUE: 30-40 N·m (3.0-4.0 kg-m, 22-29 ft-lb)

Install the hand rail and the reflectors.

REFLECTOR

HAND RAIL

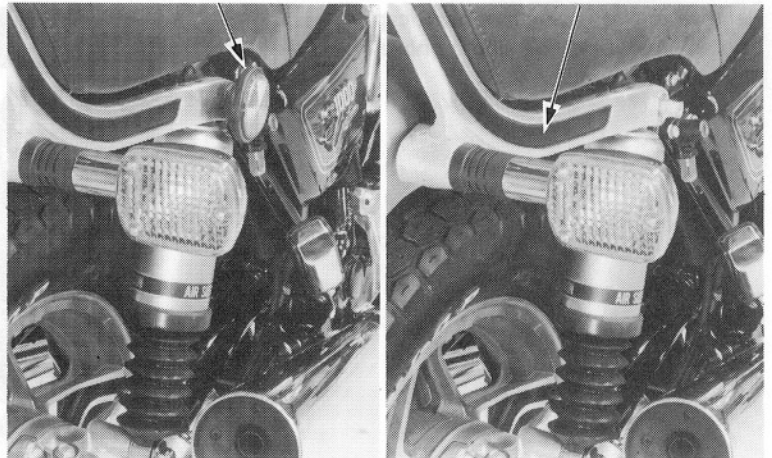

Connect the air hose to the 3-way joint.

Install the 3-way joint and connect the switch wire.

Fill the rear shock absorber with air to 0-400 kPa
(0-4.0 kg/cm², 0-57 psi).

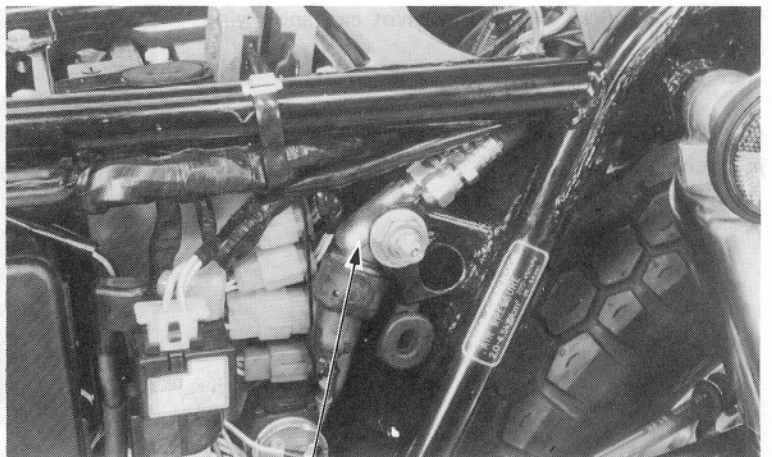

3-WAY JOINT



REAR WHEEL/SUSPENSION

SWING ARM

REMOVAL

Remove the rear wheel (Page 15-2).
Remove the rear shock absorber lower mounting bolt and nut.
Remove the brake hose from the swing arm.

Remove the cotter pin and remove the rear brake caliper.

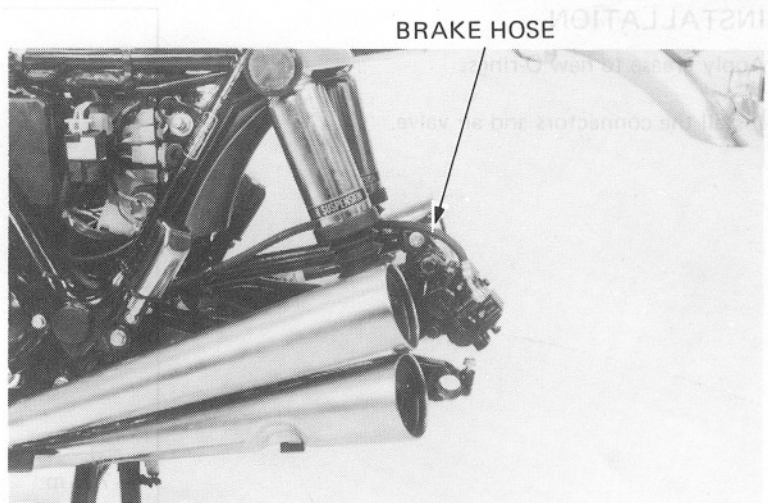

**SWING ARM PIVOT
LOCK NUT WRENCH**
07908-4690001 OR KS-HBA-08-469
(U.S.A. only)

Remove the left swing arm pivot cap.
Loosen the lock nut and remove the swing arm pivot adjusting bolt.

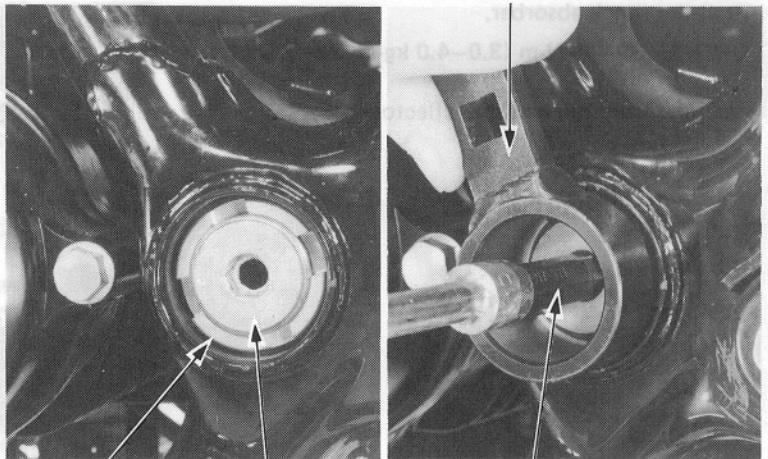

LOCK NUT ADJUSTING BOLT HEX WRENCH, 10 mm
07917-3710000 OR
COMMERCIALY AVAILABLE

Remove the right swing arm pivot cap and swing arm pivot bolt.
Remove the swing arm.

Detach the rubber boot and remove the universal joint circlip.

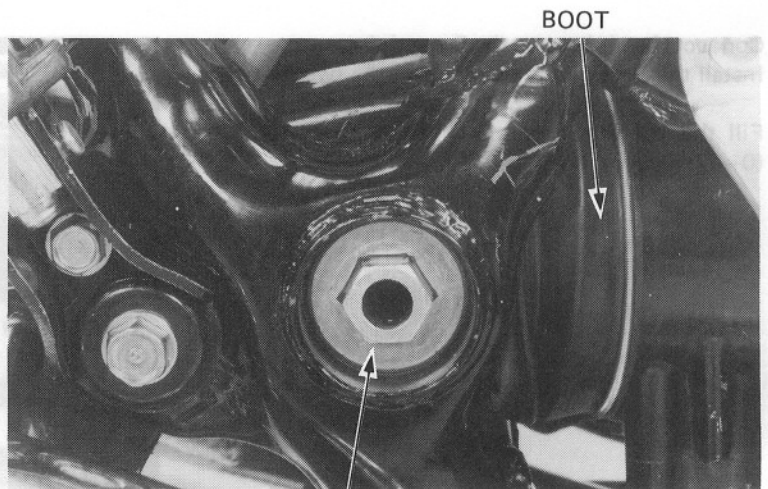

PIVOT BOLT



DISASSEMBLY

Straighten the lock washer tab and remove the brake torque link.

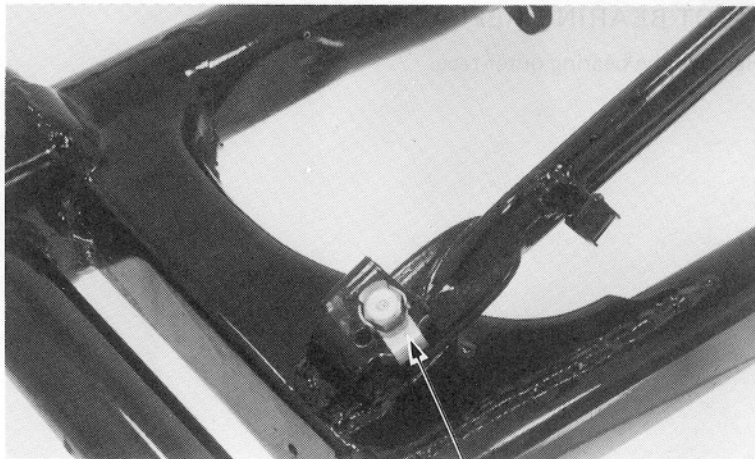

LOCK WASHER

Remove the circlip and drive shaft coupling.

Remove the drive shaft from the swing arm.

Remove the dust seal and pivot bearing.

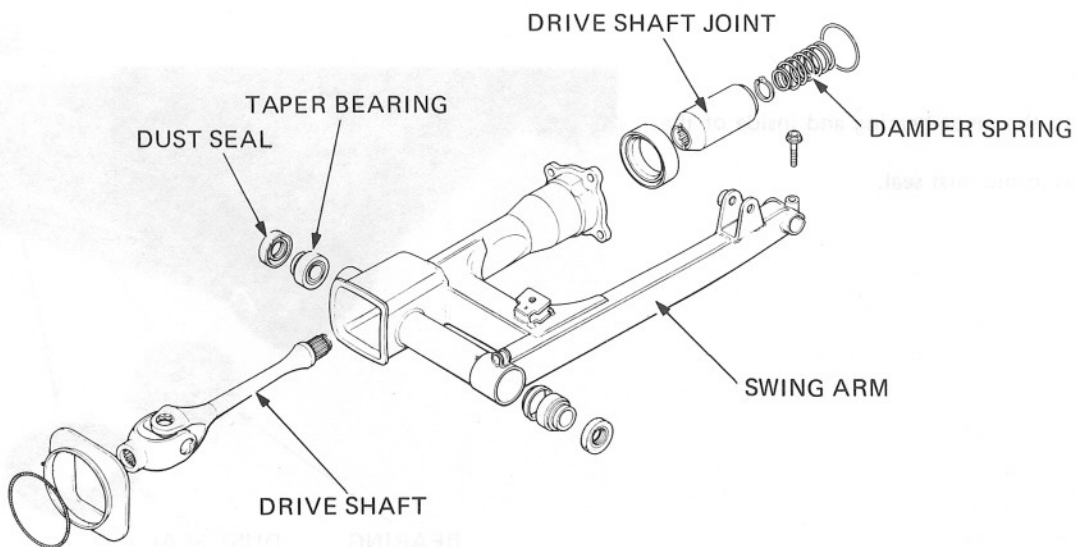



REAR WHEEL/SUSPENSION

PIVOT BEARING REPLACEMENT

Remove the bearing outer race.

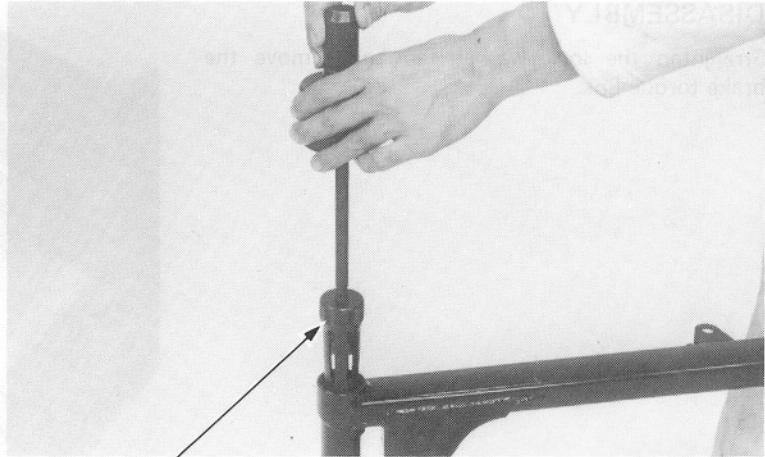

BEARING
REMOVER 07936-8890100

Drive in a new bearing outer race into the swing arm left pivot.

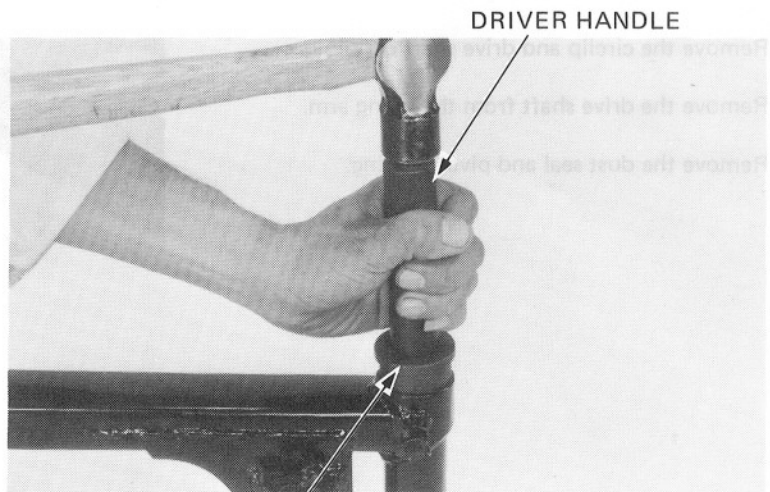

BEARING DRIVER, 37 x 40 mm

ASSEMBLY

Apply grease to the pivot bearing and inside of the dust seal.
Install the bearing and dust seal.

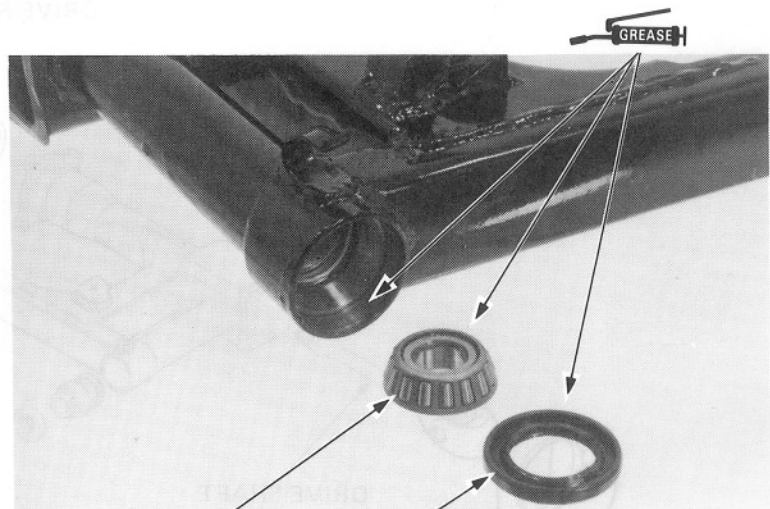

BEARING DUST SEAL



Apply Multipurpose NLGI No. 2 Grease (MoS₂-additive) to the drive shaft, dust seal and joint. Install the drive shaft, joint and circlip.

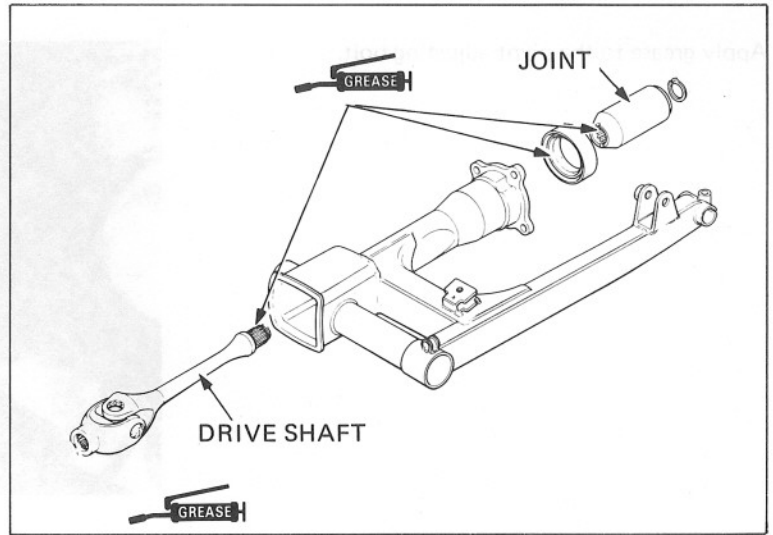

Apply grease to the brake torque link pivot collar. Install the brake torque link with a new lock washer.

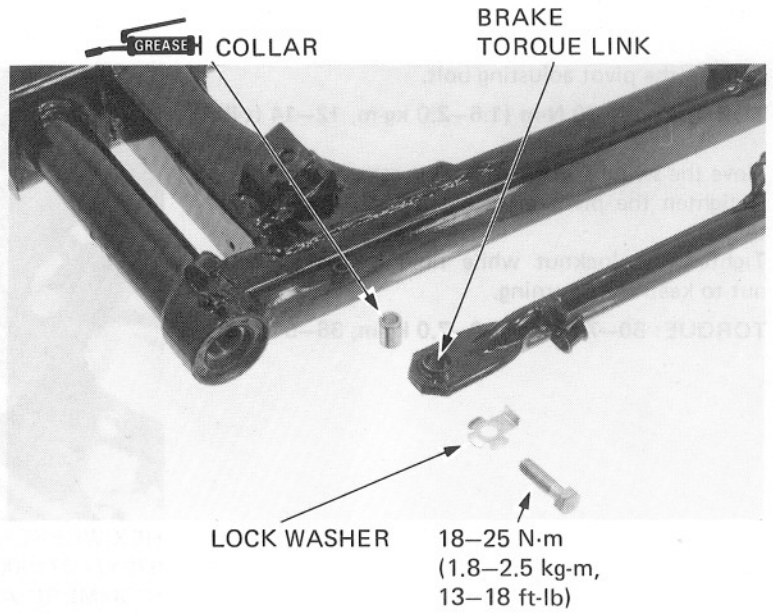

INSTALLATION

Apply grease to the pivot bolt tip. Align the universal joint and drive shaft before the swing arm is in position. Install the swing arm and pivot bolt.

TORQUE: 50-70 N-m (5.0-7.0 kg-m, 36-51 ft-lb)

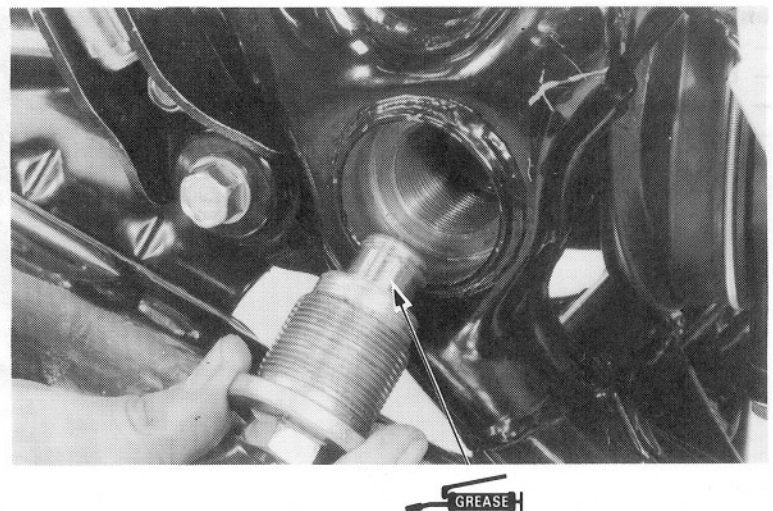



Apply grease to the pivot adjusting bolt.



ADJUSTING
BOLT

SWING ARM PIVOT
LOCK NUT WRENCH
07908-4690001
OR KS-HBA-08-469 (U.S.A. only)

Tighten the pivot adjusting bolt.

TORQUE: 16–20 N·m (1.6–2.0 kg·m, 12–14 ft·lb)

Move the swing arm up and down several times.
Retighten the pivot adjusting bolt to the specified torque.

Tighten the locknut while holding the adjusting nut to keep from turning.

TORQUE: 50–70 N·m (5.0–7.0 kg·m, 36–51 ft·lb)

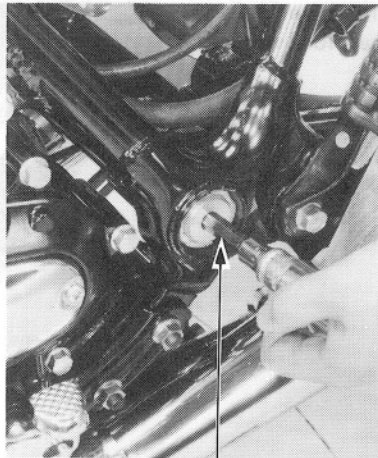

HEX WRENCH, 10 mm
07917-3710000 OR
(COMMERCIALY AVAILABLE)



Install the following:

- rear brake caliper.
- brake hose.
- rear shock absorber lower mounting bolt and nut.
- rear wheel (Page 15-6).

