

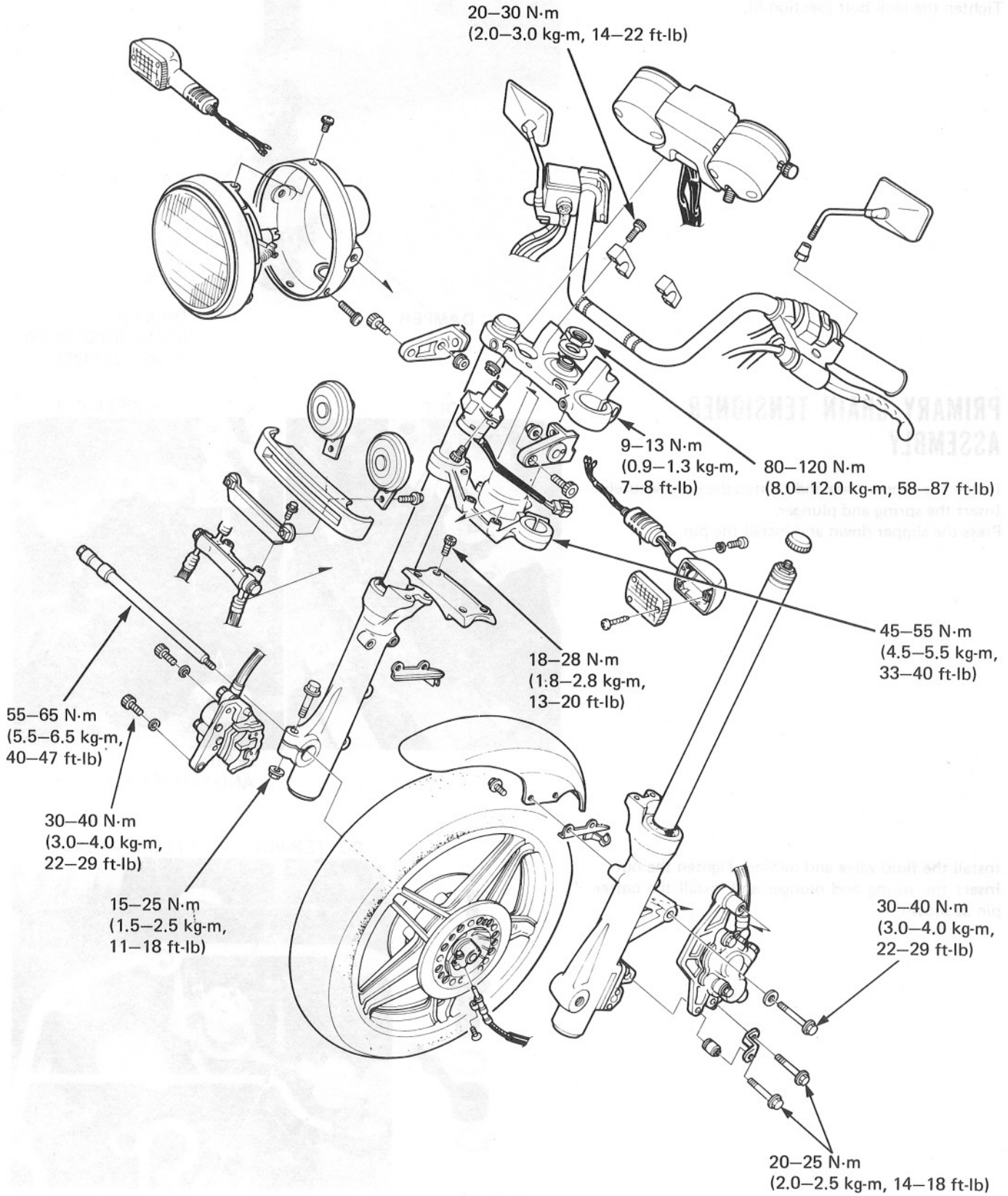

FRONT WHEEL/SUSPENSION





14. FRONT WHEEL/SUSPENSION

SERVICE INFORMATION	14- 1
TROUBLESHOOTING	14- 2
HEADLIGHT	14- 3
INSTRUMENTS	14- 4
HANDLEBAR	14- 6
FRONT WHEEL	14-11
FRONT FORK	14-16
STEERING STEM	14-26

SERVICE INFORMATION

GENERAL

- A jack or other support is required to support the motorcycle.
- Never ride on the rim or try to bend the wheel.
- Avoid damaging the cast wheel.

SPECIFICATIONS

		STANDARD	SERVICE LIMIT
Axle shaft runout		—————	0.2 mm (0.01 in)
Front wheel rim runout	Radial	0.3 mm (0.01 in) max.	2.0 mm (0.08 in)
	Axial	0.3 mm (0.01 in) max.	2.0 mm (0.08 in)
Wheel bearing play		—————	0.03 mm (0.001 in)
Fork spring free length		480.9 mm (18.9 in)	471.3 mm (18.6 in)
Fork tube runout		—————	0.2 mm (0.01 in)
Front fork fluid capacity		Right 455 cc (15.4 oz) Left 470 cc (15.9 oz)	—————
Front fork air pressure		40–100 kPa (0.4–1.0 kg/cm ² , 6–14 psi)	—————

TORQUE VALUES

Handlebar upper holder	20–30 N·m (2.0–3.0 kg·m, 14–22 ft·lb)
Caliper mounting bolt	30–40 N·m (3.0–4.0 kg·m, 22–29 ft·lb)
Front axle	55–65 N·m (5.5–6.5 kg·m, 40–47 ft·lb)
Axle pinch bolt	15–25 N·m (1.5–2.5 kg·m, 11–18 ft·lb)
Front fork socket bolt	15–25 N·m (1.5–2.5 kg·m, 11–18 ft·lb)
Fork tube cap	15–30 N·m (1.5–3.0 kg·m, 11–22 ft·lb)
Steering bearing adjustment nut	14–16 N·m (1.4–1.6 kg·m, 10–12 ft·lb)
Steering stem nut	80–120 N·m (8.0–12.0 kg·m, 58–87 ft·lb)
Brake disc	30–35 N·m (3.0–3.5 kg·m, 22–25 ft·lb)
Fork top bridge pinch bolt	9–13 N·m (0.9–1.3 kg·m, 7–9 ft·lb)
Fork bottom pinch bolt	45–55 N·m (4.5–5.5 kg·m, 33–40 ft·lb)

14



FRONT WHEEL/SUSPENSION

TOOLS

Special	
Hex. wrench, 6 mm	07917-3230000 or commercially available
Snap ring pliers	07914-3230001 or commercially available
Fork seal driver	07947-4630100
Steering stem socket	07916-3710100
Bearing race driver attachment	07946-3710701
Bearing race remover	07946-3710500
Bearing race remover	07953-4250002
Steering stem driver	07946-MB00000
Common	
Driver	07749-0010000
Attachment, 42 x 47 mm	07746-0010300
Pilot, 15 mm	07746-0040300
Lock nut wrench, 30 x 32 mm	07716-0020400 or commercially available
Extension bar	07716-0020500 or commercially available
Bearing driver outer, 52 x 55 mm	07746-0010400

TROUBLESHOOTING

Hard steering

1. Steering bearing adjustment nut too tight.
2. Faulty steering stem bearings.
3. Damaged steering stem bearings.
4. Insufficient tire pressure.

Steers to one side or does not track straight

1. Unevenly adjusted right and left shock absorbers.
2. Bent front forks.
3. Bent front axle; wheel installed incorrectly.

Front wheel wobbling

1. Bent rim.
2. Worn front wheel bearings.
3. Faulty tire.
4. Axle nut not tightened properly.

Soft suspension

1. Weak for springs.
2. Insufficient fluid in front forks.
3. Front fork air pressure incorrect.

Hard suspension

1. Incorrect fluid weight in front forks.
2. Front fork air pressure incorrect.
3. Bent fork tubes.
4. Clogged fluid passage.
5. Clogged anti-dive orifice.

Front suspension noise

1. Worn slider or guide bushings.
2. Insufficient fluid in forks.
3. Loose front fork fasteners.
4. Lack of grease in speedometer gearbox.



HEADLIGHT

Remove the three headlight mounting screws. Disconnect the wire coupler and remove the headlight.

HEADLIGHT MOUNTING SCREWS

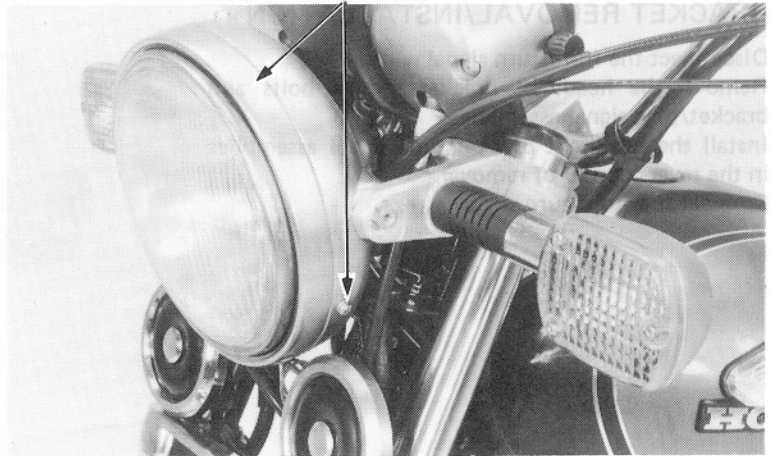

Remove the retaining screws and horizontal adjusting screw from the rim. Remove the two headlight unit retaining screws, and headlight.

Assembly and installation is essentially the reverse of disassembly; connect the wire coupler and install the headlight with the mounting screws.

After reinstalling the headlight, adjust the headlight beam aim (Page 3-18).

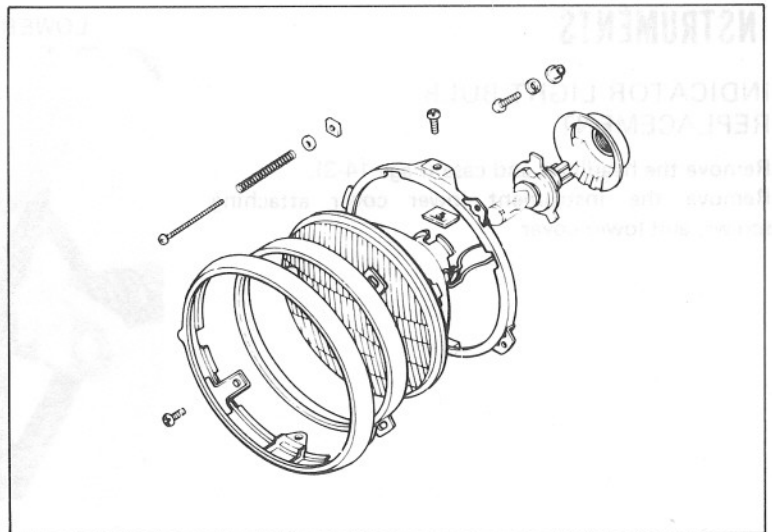

HEADLIGHT CASE

Remove the headlight case mounts and headlight case.

Install the headlight case in the reverse order of removal.

Align the index marks on the headlight case with the punch marks on the brackets.

PUNCH MARKS

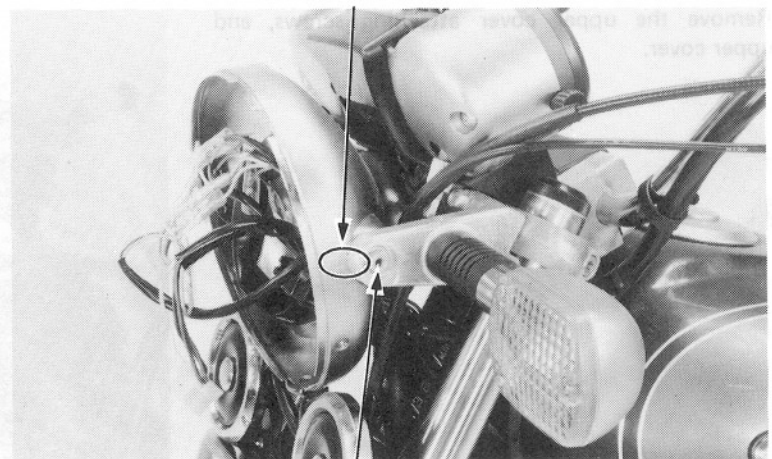

HEADLIGHT CASE MOUNT

FRONT WHEEL/SUSPENSION
BRACKET REMOVAL/INSTALLATION

Disconnect the front turn signal wires.
 Remove the headlight bracket mount bolts and bracket/turn signal assemblies.
 Install the headlight bracket/turn signal assemblies in the reverse order of removal.
 Connect the front turn signal wires.

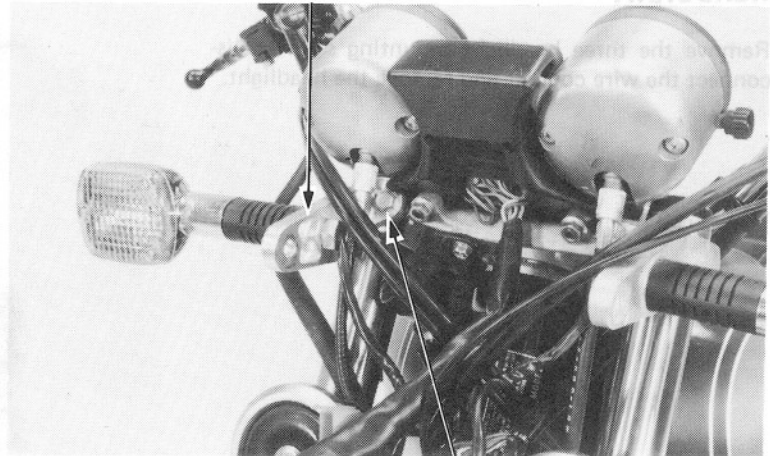
HEADLIGHT BRACKET

BOLT
INSTRUMENTS
INDICATOR LIGHT BULB REPLACEMENT

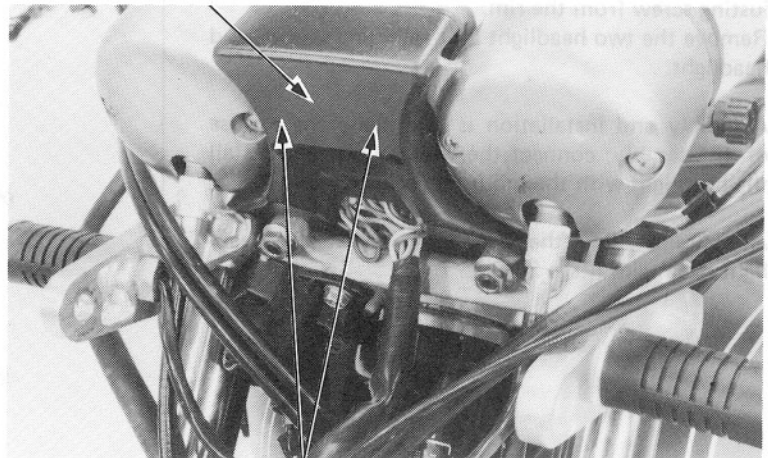
Remove the headlight and case (Page 14-3).
 Remove the instrument lower cover attaching screws, and lower cover.

LOWER COVER

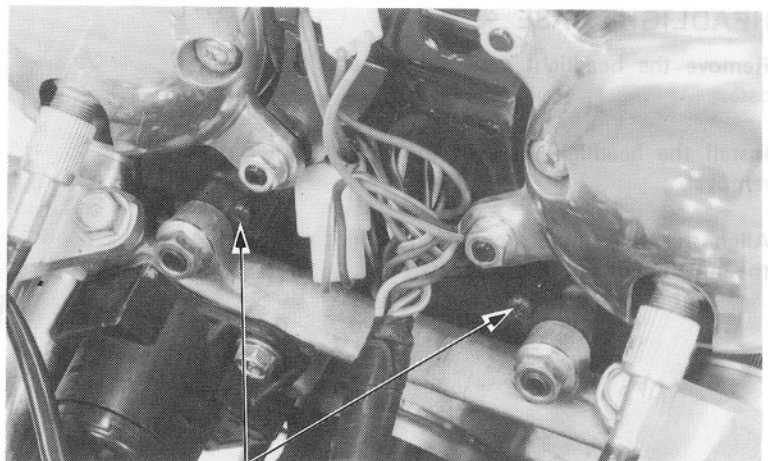
SCREWS

Remove the upper cover attaching screws, and upper cover.

SCREWS

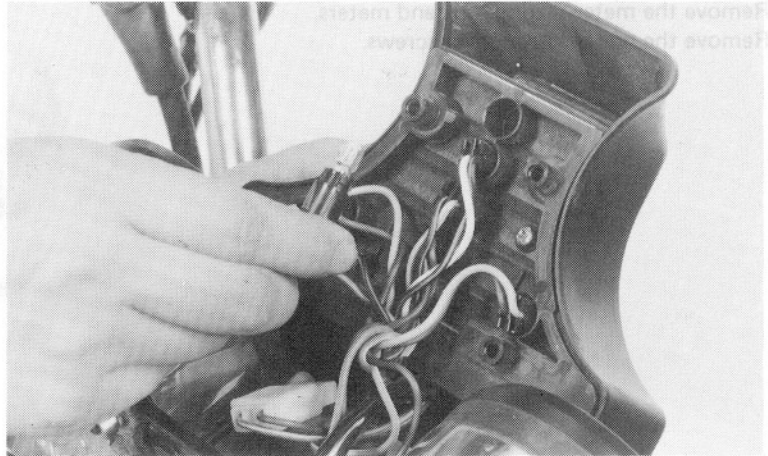

Replace the bulb.
After installing a new bulb, check for continuity. If the bulb does not light, inspect the wiring for an open or short circuit, or check for loose connections.



REMOVAL

Remove the headlight and case (Page 14-3).
Disconnect the speedometer cable and tachometer cable from the instruments.
Disconnect the instrument wire couplers.
Remove the instrument mounting nuts, and instruments.

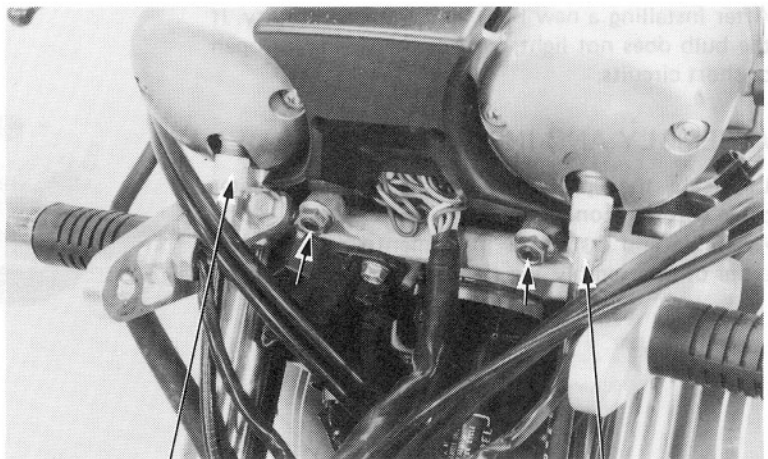

TACHOMETER CABLE

SPEEDOMETER CABLE

METER BULB REPLACEMENT

Remove the instrument lower cover.

CAUTION

Do not leave the instrument upside down for a long time.

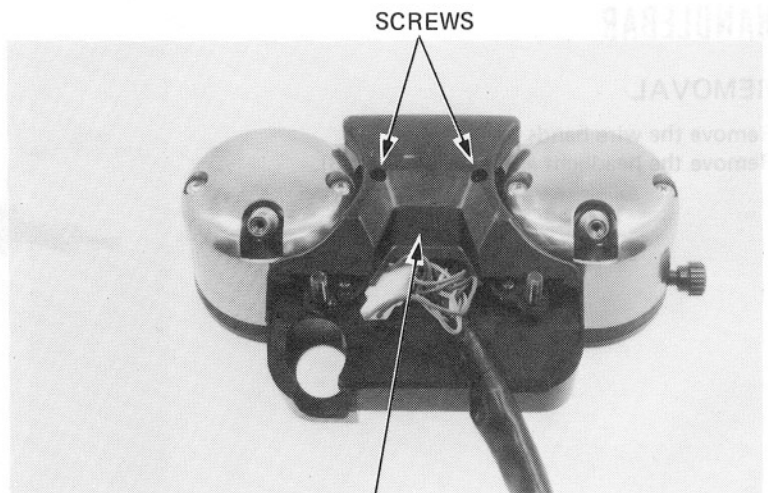

SCREWS

LOWER COVER

FRONT WHEEL/SUSPENSION

Remove the meter setting nuts and meters.
 Remove the meter lower cover screws.

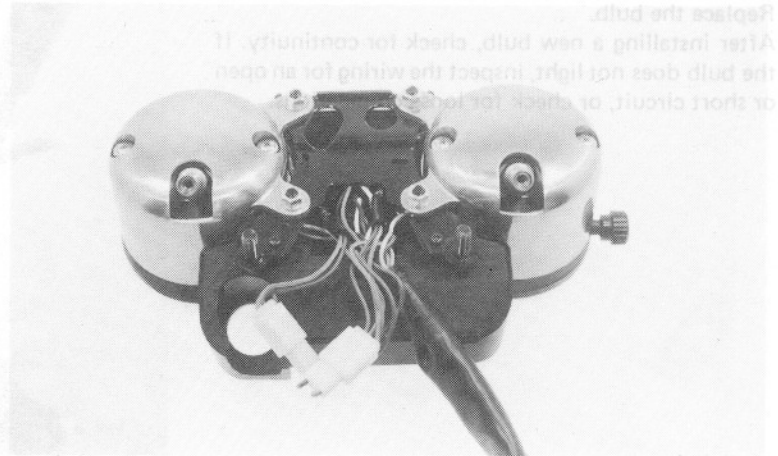

After installing a new bulb, check for continuity. If the bulb does not light, inspect the wiring for open or short circuits.

ASSEMBLY AND INSTALLATION

Lubricate the speedometer cable and tachometer cable before reconnecting.
 Assemble and install the instruments in the reverse order of disassembly and removal.

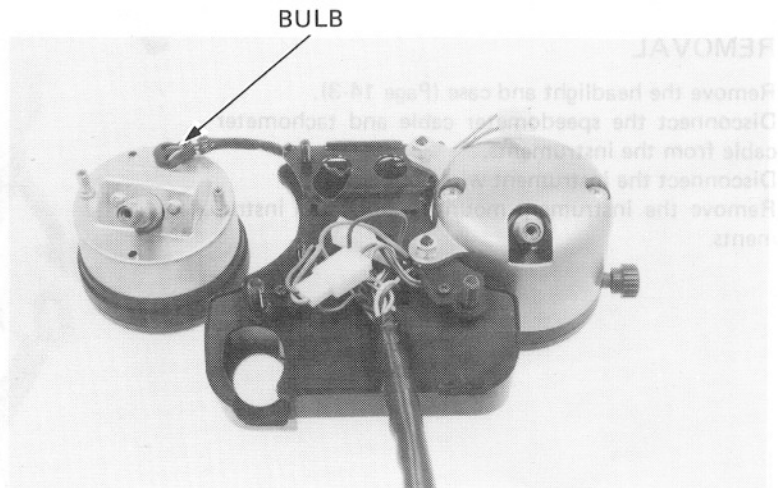

HANDLEBAR

REMOVAL

Remove the wire bands.
 Remove the headlight and case (Page 14-3).

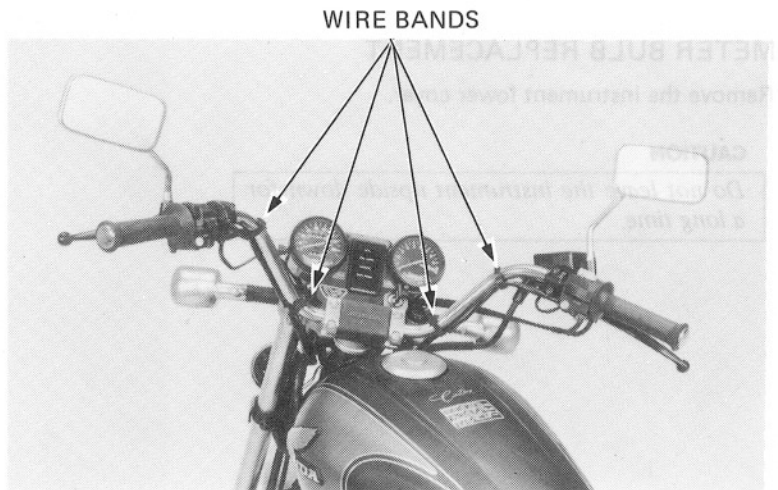



Disconnect the clutch switch wires.
Remove the left handlebar switch and disconnect
the clutch cable.

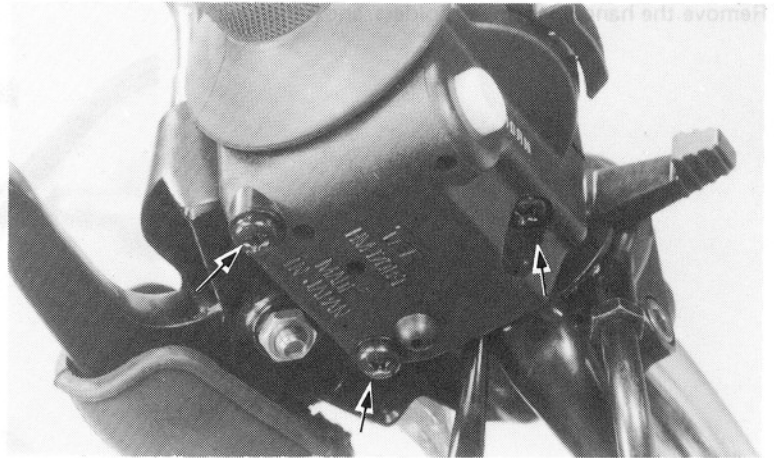

Remove the choke lever holder.
Disconnect the choke cable from the choke lever.

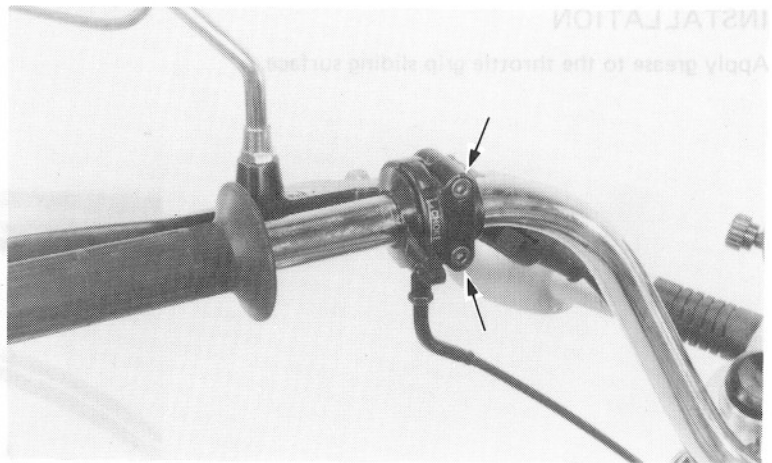

Disconnect the brakelight switch wires.
Remove the right handlebar switch and throttle
grip.
Remove the front master cylinder with the brake
lever.

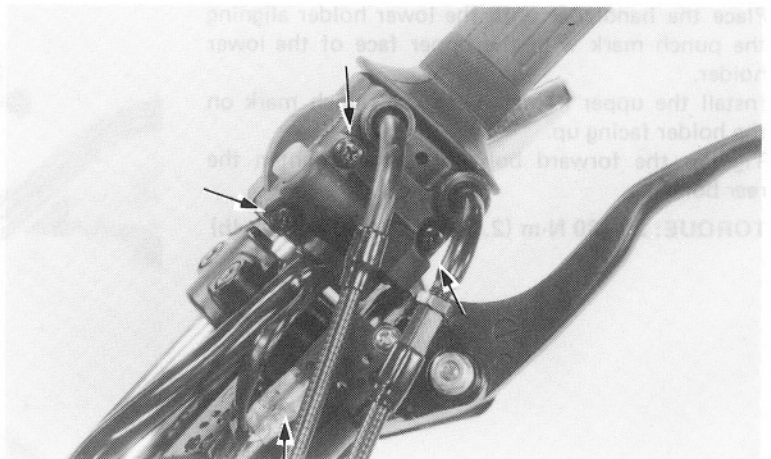

FRONT WHEEL/SUSPENSION

Remove the handlebar upper holders, and handlebar.

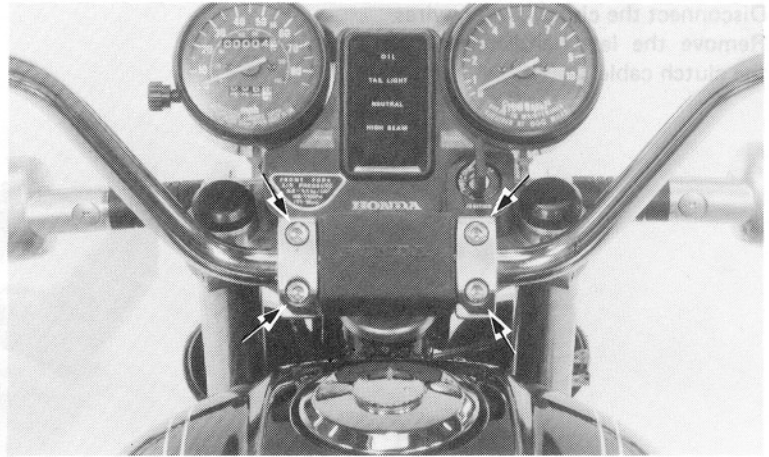

INSTALLATION

Apply grease to the throttle grip sliding surface.

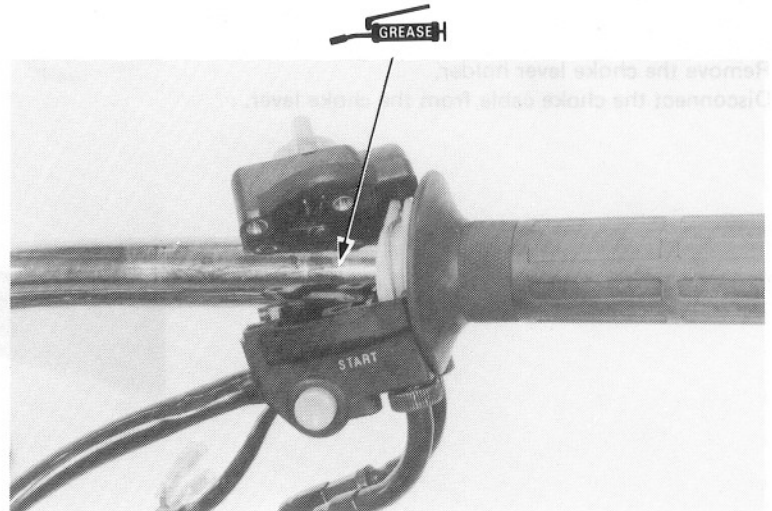

Place the handlebar onto the lower holder aligning the punch mark with the upper face of the lower holder.

Install the upper holders with the punch mark on the holder facing up.

Tighten the forward bolts first, then tighten the rear bolts.

TORQUE: 20–30 N·m (2.0–3.0 kg·m, 14–22 ft·lb)

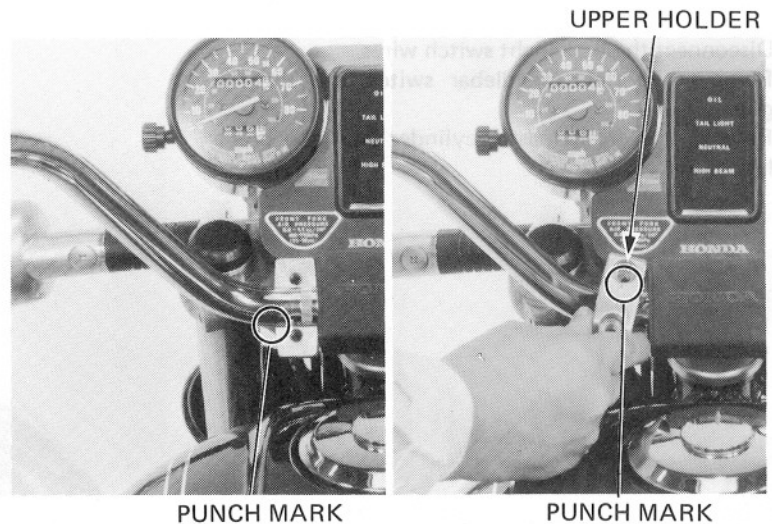

PUNCH MARK

PUNCH MARK

UPPER HOLDER



Install the front brake master cylinder with "UP" mark on the holder facing up. Align the end of the holder with the handlebar punch mark. Tighten the upper bolt first, then the lower bolt.

Install the right handlebar switch and connect the brake light switch wires.

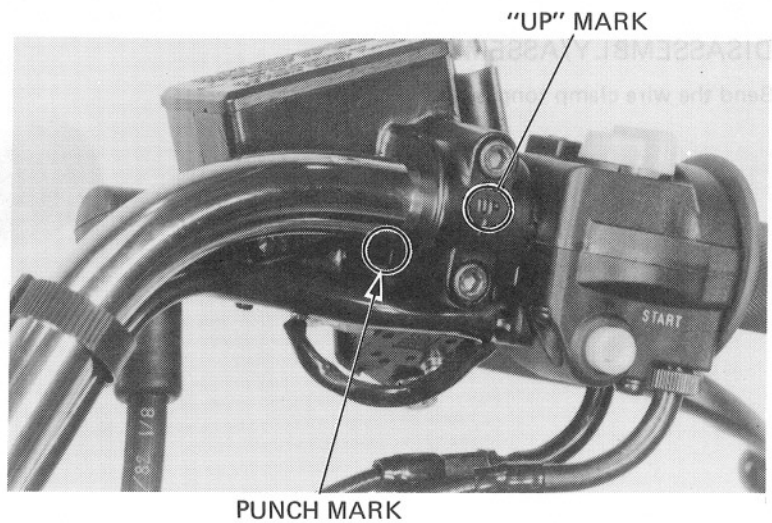

Connect the choke cable to the choke lever. Align the end of the holder with the punch mark on the handlebar. Tighten the upper bolt first, then the lower bolt.

Install the left handlebar switch and connect the clutch switch wires. Connect the clutch cable. Route the switch wires (Page 1-11) and install the headlight and case (Page 14-3).

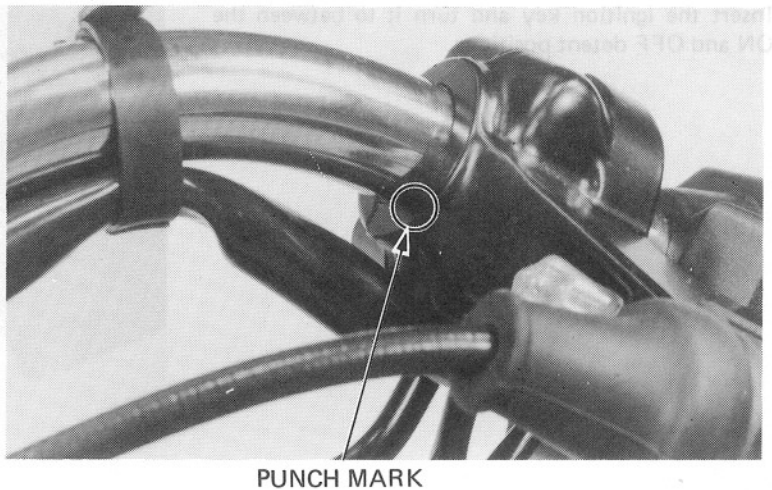

IGNITION SWITCH REPLACEMENT

Remove the headlight and headlight case (Page 14-3). Disconnect the ignition switch wire coupler. Remove the ignition switch mounting bolts, and ignition switch.

Install the ignition switch in the reverse order of removal.

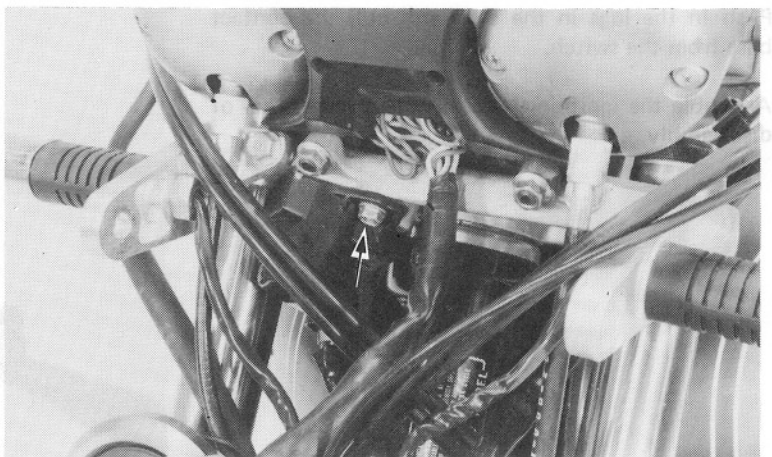

FRONT WHEEL/SUSPENSION
DISASSEMBLY/ASSEMBLY

Bend the wire clamp tongue up.

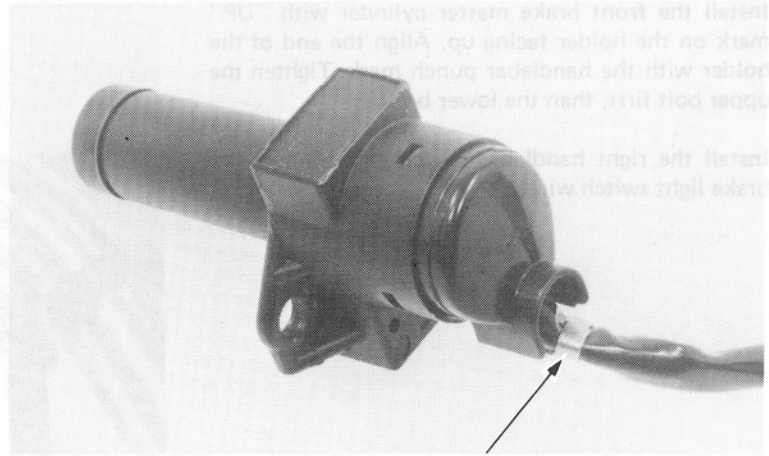

WIRE CLAMP

Insert the ignition key and turn it to between the ON and OFF detent positions.

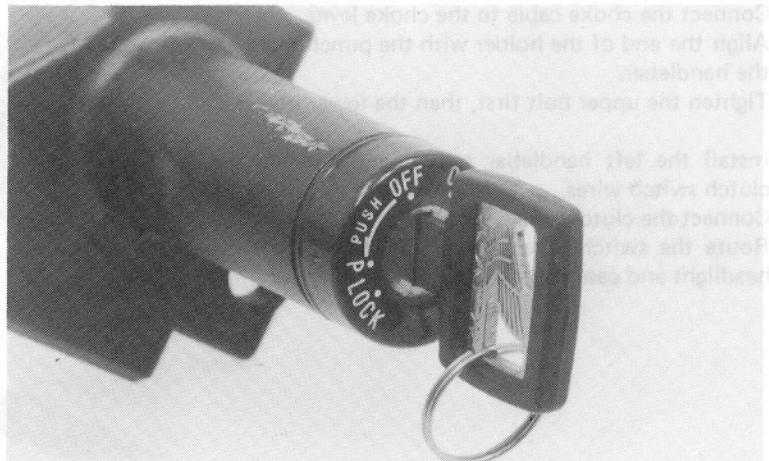

Push in the lugs in the slots and pull the contact base from the switch.

Assemble the ignition switch in the reverse order of disassembly.

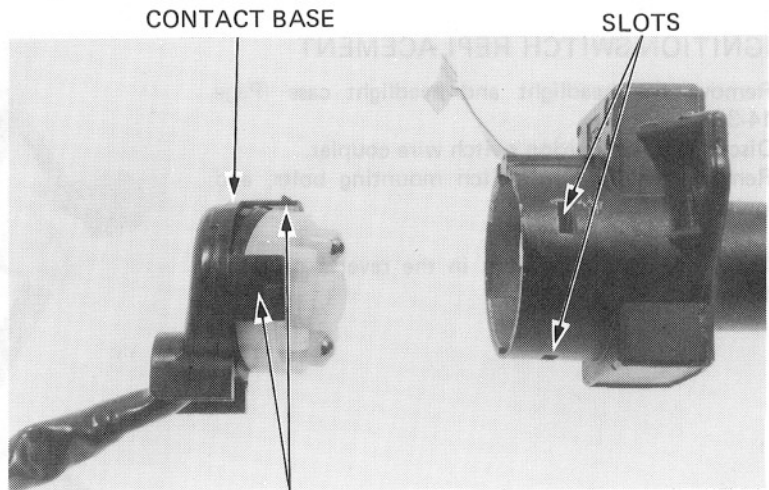

CONTACT BASE

SLOTS

LUGS



FRONT WHEEL

REMOVAL

Remove the speedometer cable set screw and the speedometer cable.

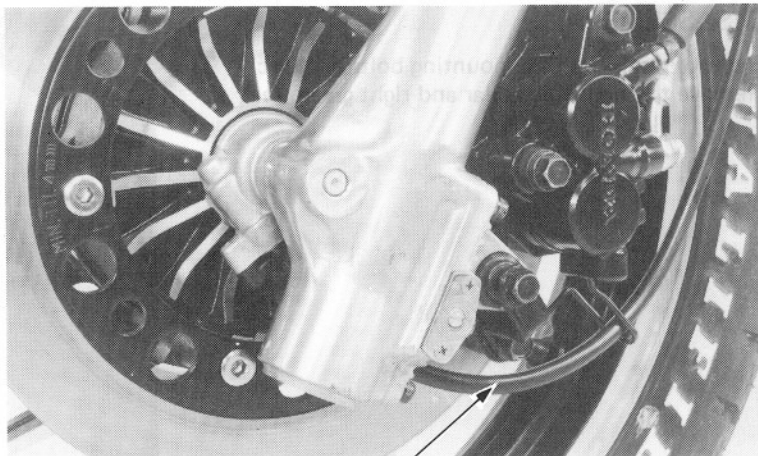

SPEEDOMETER CABLE

Remove the right caliper assemblies by loosening the bolts.

NOTE

Do not operate the front brake lever after removing the caliper. To do so will cause difficulty in refitting the brake disc between the brake pads.

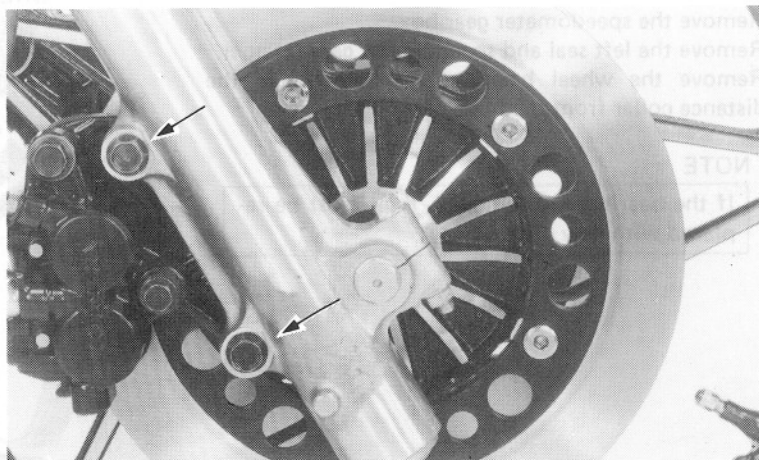

Loosen the axle pinch bolt.
Loosen and remove the front axle.
Remove the front wheel.

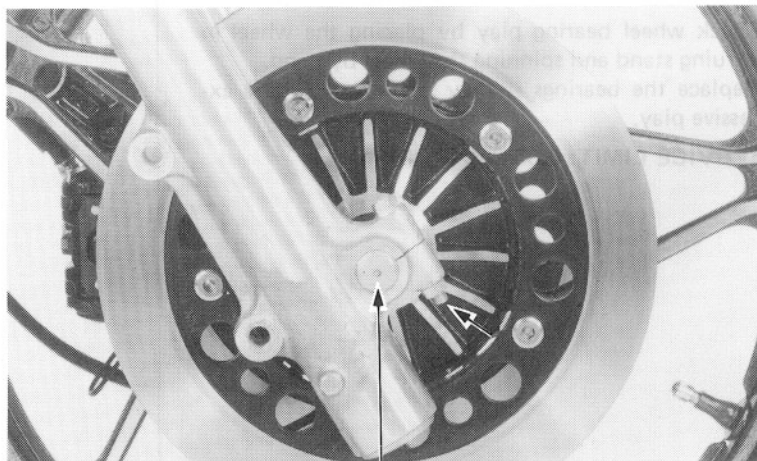

FRONT AXLE



FRONT WHEEL/SUSPENSION

DISASSEMBLY

Remove the brake disc mounting bolts and disc.
Remove the right side collar and right grease seal.

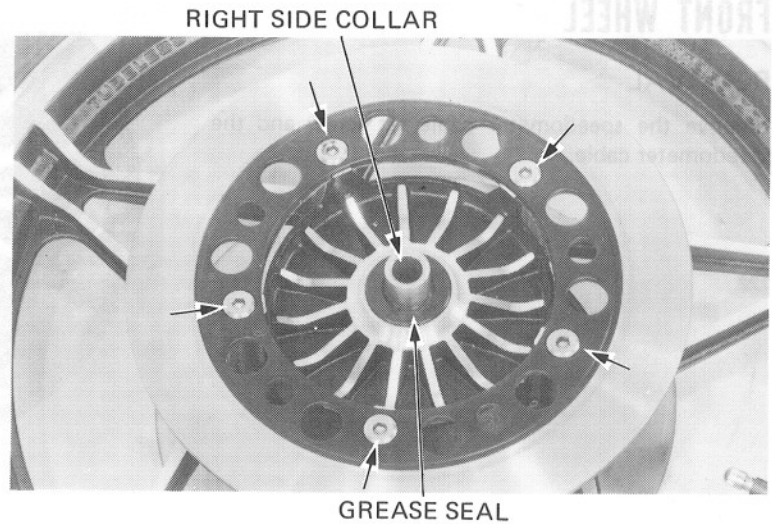

Remove the speedometer gear box.
Remove the left seal and speedometer gear retainer.
Remove the wheel bearings (see below) and the distance collar from the hub.

NOTE

If the bearings are removed, they must be replaced with new ones.

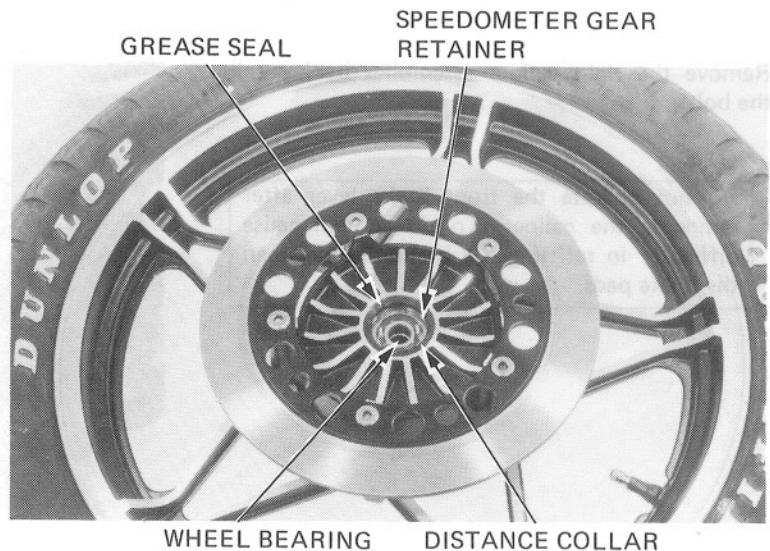

WHEEL BEARING INSPECTION

Check wheel bearing play by placing the wheel in a truing stand and spinning the wheel by hand.
Replace the bearings if they are noisy or have excessive play.

SERVICE LIMIT: 0.03 mm (0.001 in)

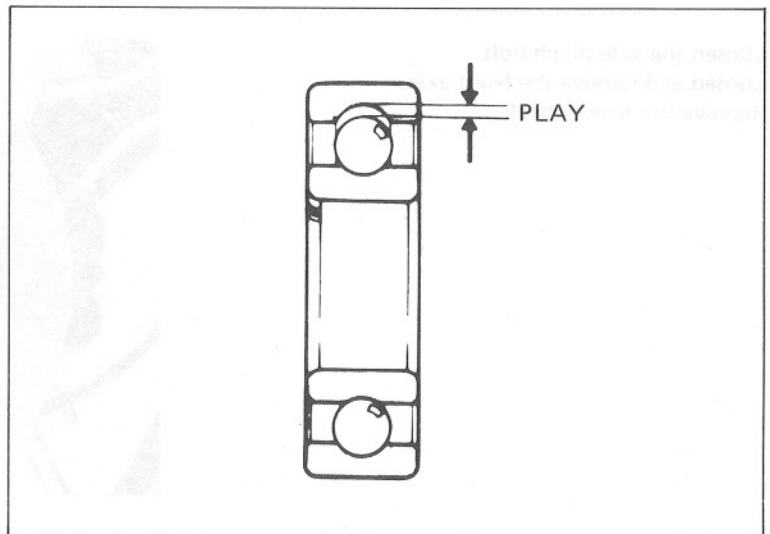



WHEEL INSPECTION

Check the rim runout by placing the wheel in a truing stand. Spin the wheel slowly and read the runout using a dial indicator.

SERVICE LIMITS:

RADIAL RUNOUT: 2.0 mm (0.08 in)

AXIAL RUNOUT: 2.0 mm (0.08 in)

NOTE

The wheel cannot be repaired and must be replaced with a new one if the service limits are exceeded.

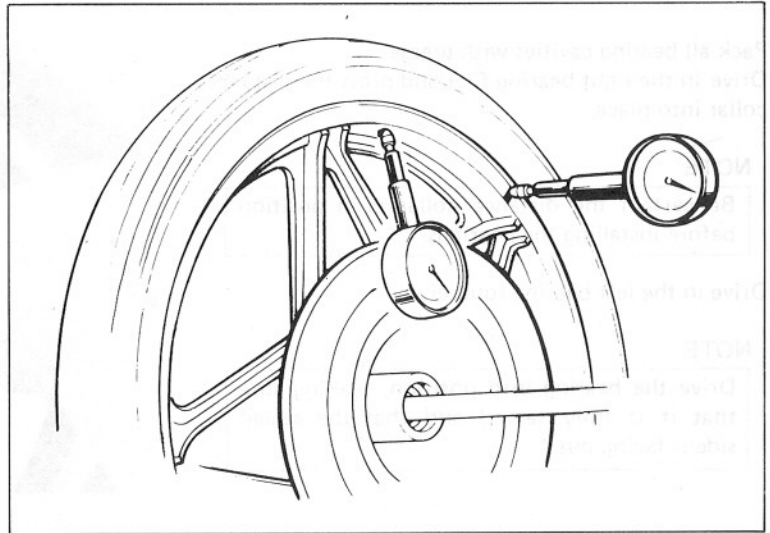

AXLE INSPECTION

Set the axle in V blocks and measure the runout. The actual runout is 1/2 of the total indicator reading.

SERVICE LIMIT: 0.2 mm (0.01 in)

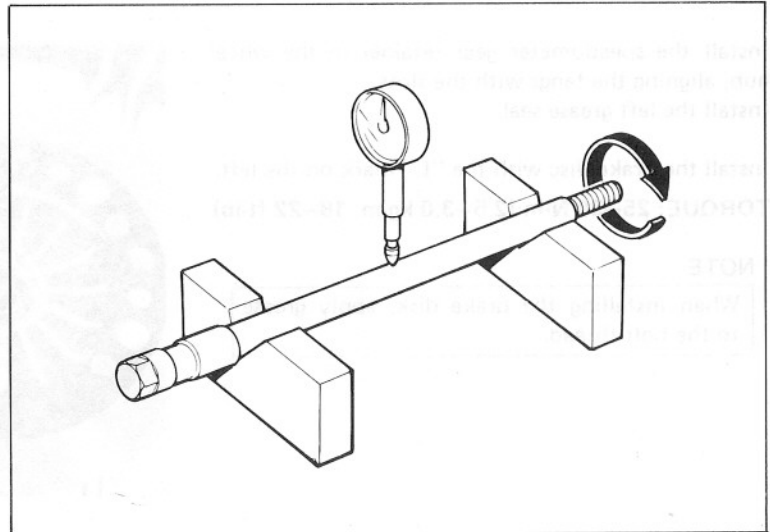

ASSEMBLY

WARNING

Do not get grease on the brake disc or stopping power will be reduced.

NOTE

The cast wheel has no rim band. The front wheel uses a tubeless tire. For tubeless tire repair, refer to the HONDA tubeless tire manual.

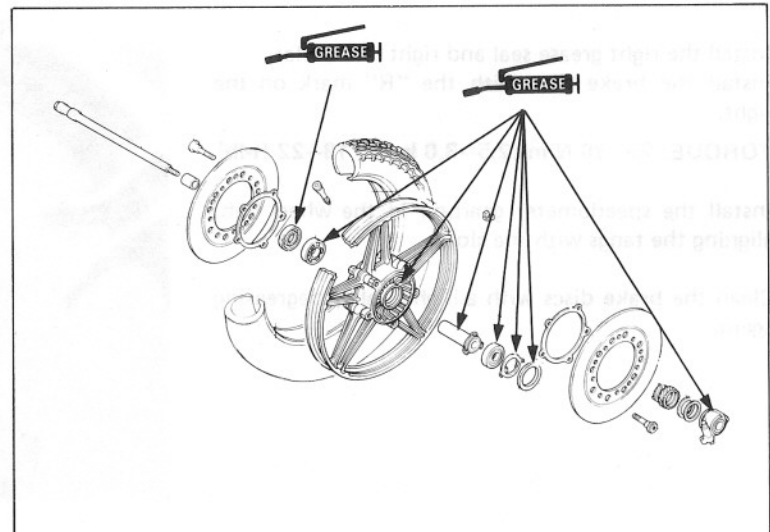



FRONT WHEEL/SUSPENSION

Pack all bearing cavities with grease.
Drive in the right bearing first and press the distance collar into place.

NOTE

Be certain the distance collar is in position before installing the bearings.

Drive in the left bearing squarely.

NOTE

Drive the bearing into position, making sure that it is fully seated and that the sealed side is facing out.

DRIVER
07749-0010000

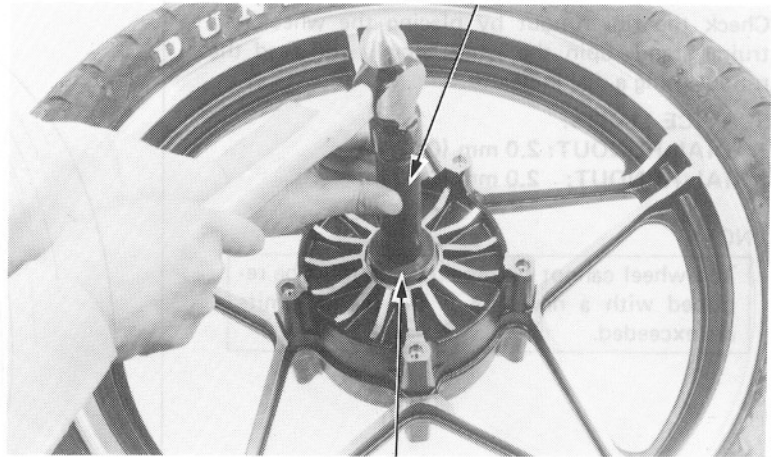

ATTACHMENT, 42 x 47 mm 07746-0010300
PILOT, 15 mm 07746-0040300

Install the speedometer gear retainer in the wheel hub, aligning the tangs with the slots.
Install the left grease seal.

Install the brake disc with the "L" mark on the left.
TORQUE: 25-30 N·m (2.5-3.0 kg-m, 18-22 ft-lb)

NOTE

When installing the brake disk, apply grease to the bolt thread.

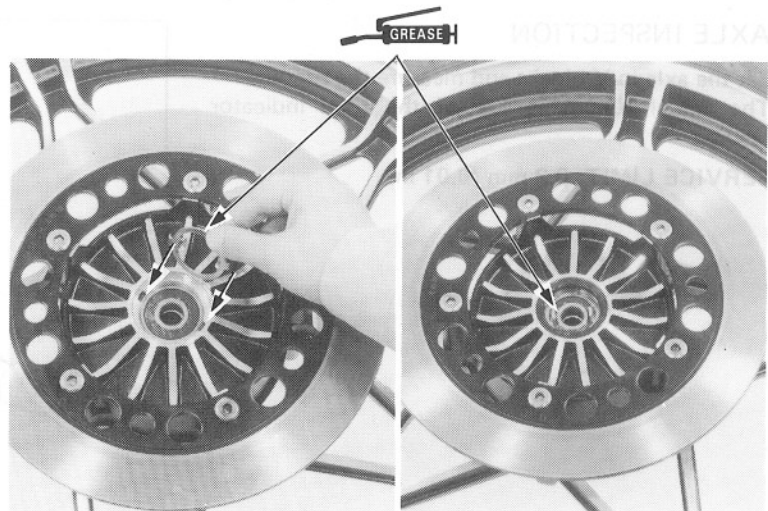

Install the right grease seal and right side collar.
Install the brake disc with the "R" mark on the right.

TORQUE: 25-30 N·m (2.5-3.0 kg-m, 18-22 ft-lb)

Install the speedometer gearbox in the wheel hub, aligning the tangs with the slots.

Clean the brake discs with a high quality degreasing agent.

RIGHT SIDE COLLAR

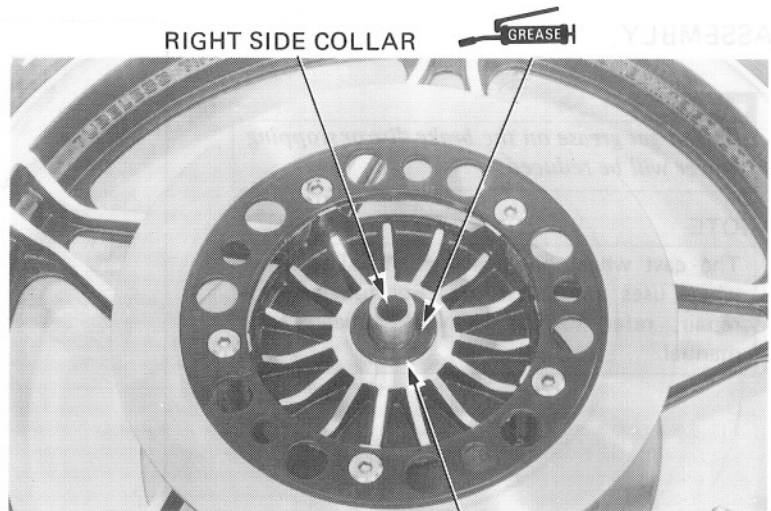

GREASE SEAL



INSTALLATION

Place the wheel between the fork tubes and align the speedometer gearbox with the tang on the left fork leg as shown.

Install the axle.

SPEEDOMETER GEARBOX

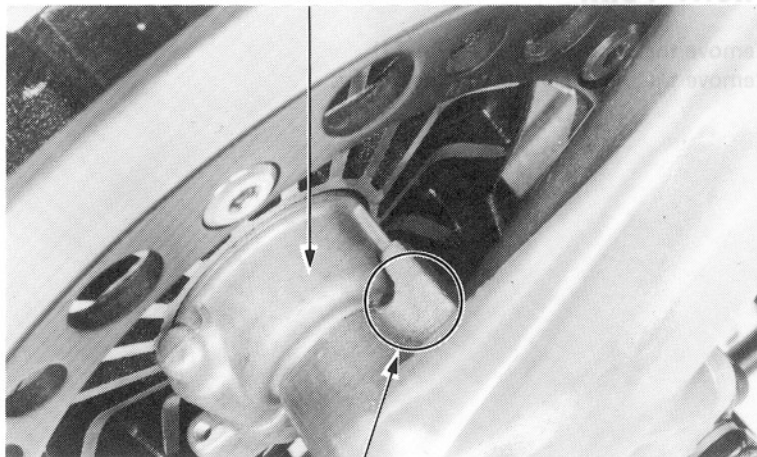

TANG ON FORK LEG

Install the right caliper assemblies, taking care not to damage the brake pads.

Tighten the caliper mounting bolts.

TORQUE: 30–40 N·m (3.0–4.0 kg-m, 22–29 ft-lb)

Tighten the axle to the specified torque.

TORQUE: 55–65 N·m (5.5–6.5 kg-m, 40–47 ft-lb)



Measure the distance between the outside surface of the right brake disc and the rear of the right caliper holder with a 0.7 mm (0.028 in) feeler gauge. If the gauge cannot be inserted, pull the right fork out until the gauge can be inserted.

Tighten the axle pinch bolt to the specified torque.

TORQUE: 15–25 N·m (1.5–2.5 kg-m, 11–18 ft-lb)

There should be at least 0.7 mm (0.028 in) clearance between the caliper holder and disc.

CAUTION:

After installing the wheel, apply the brakes several times and recheck the clearance on both sides. Failure to provide clearance will damage the brake discs and affect braking efficiency.

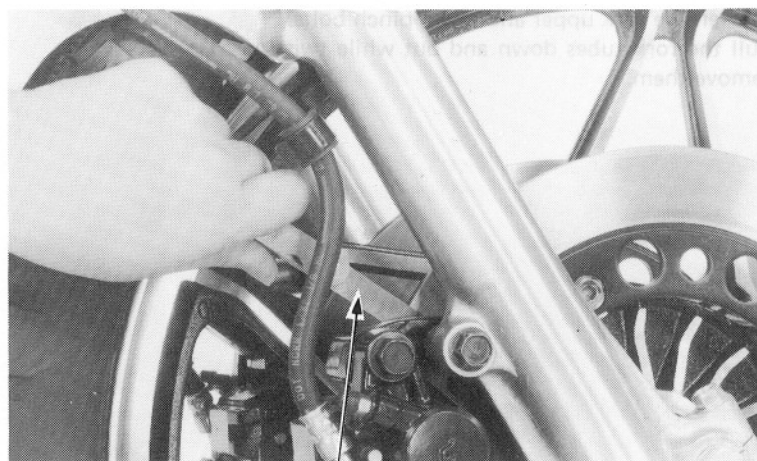

0.7 mm FEELER GAUGE

Install the speedometer cable.

FRONT WHEEL/SUSPENSION**FRONT FORK**

Remove the front wheel (Page 14-11).
Remove the brake caliper and the fender.

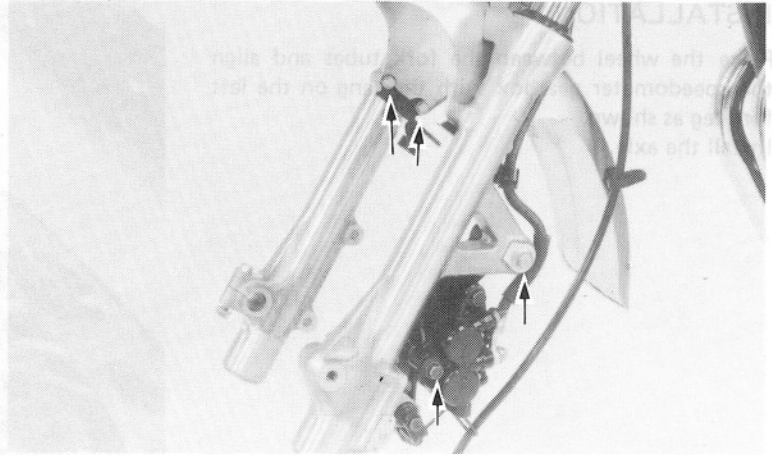

Remove the fork brace.

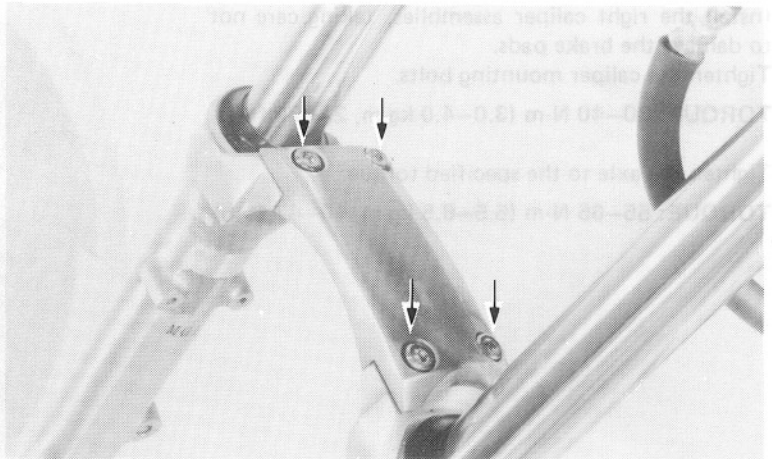

Loosen the fork upper and lower pinch bolts.
Pull the fork tubes down and out while twisting to
remove them.

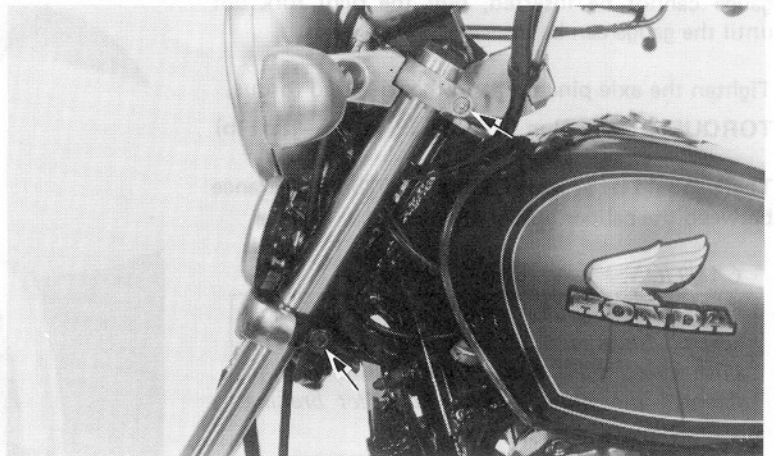



DISASSEMBLY

Depress the air valve and release front fork air pressure.

CAUTION

If air pressure is not released before disassembling, the fork cap may become a projectile.

The cap is also under spring pressure. Use care when removing and wear eye and face protection.

Hold the fork tube in a vise with soft jaws or a shop towel and remove the fork tube cap.

CAUTION

Do not damage the sliding surface.

Remove the collar, washer and fork spring.

Pour out the fork fluid by pumping the fork up and down several times.

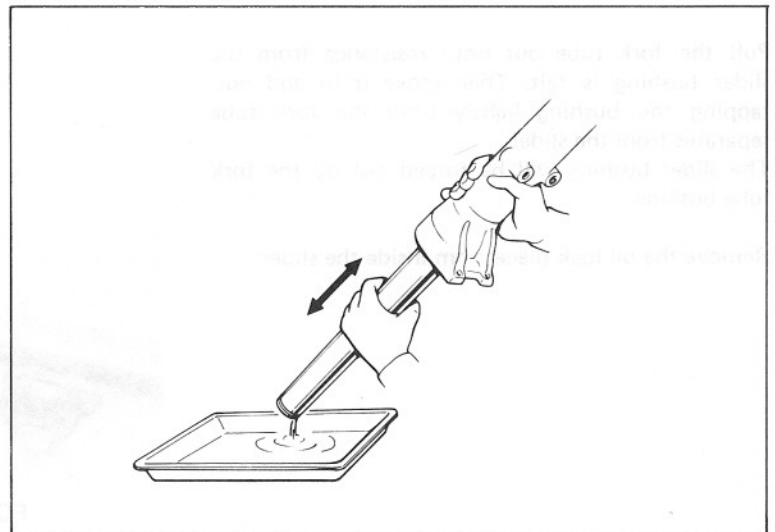
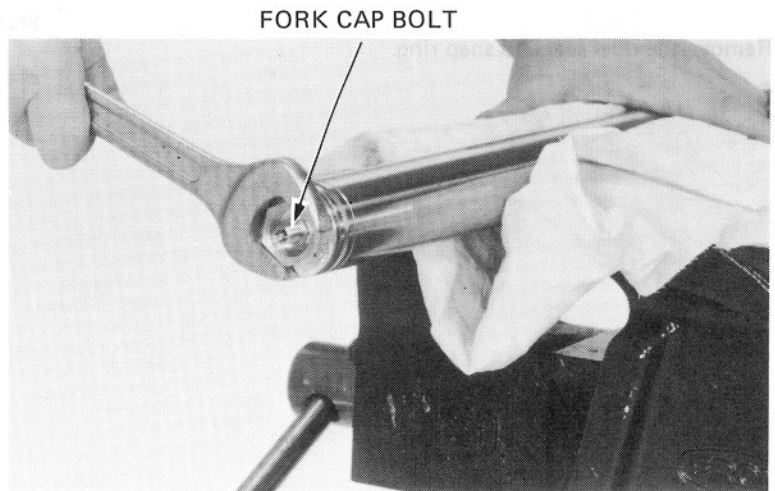

HEX WRENCH (6 mm) 07917-3230000
OR COMMERCIALY AVAILABLE

Hold the fork slider in a vise with soft jaws or a shop towel.

Remove the socket bolt with a hex wrench.

NOTE

Temporarily install the spring and fork bolt if the bolt is difficult to remove.

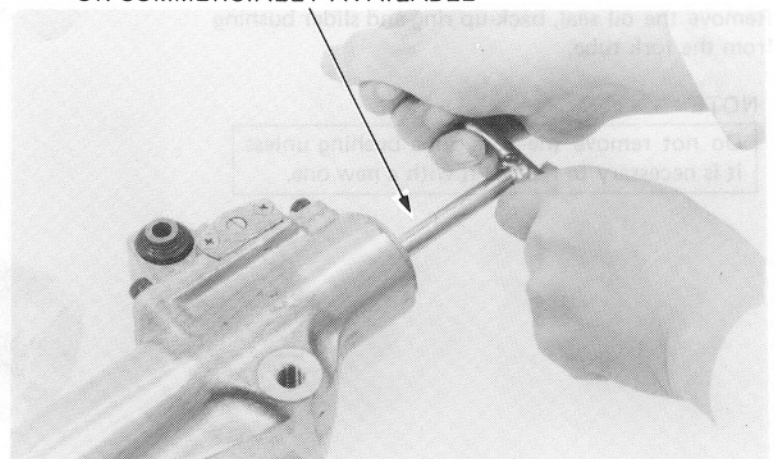



FRONT WHEEL/SUSPENSION

Remove the dust seal and snap ring.

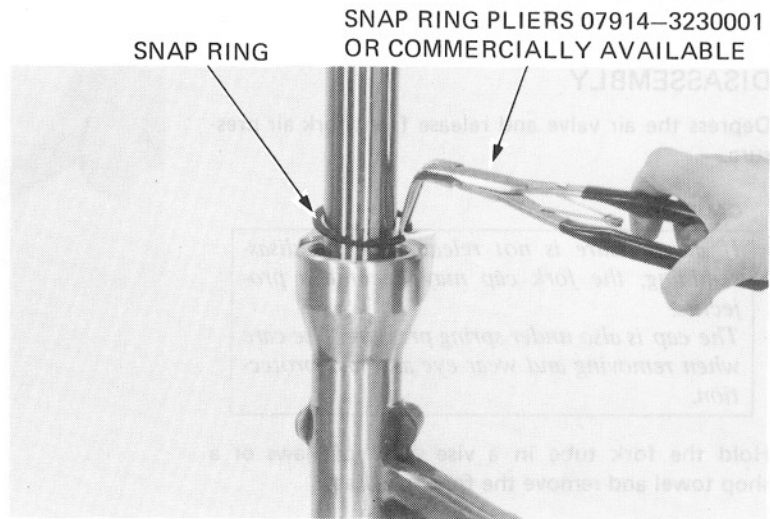

Pull the fork tube out until resistance from the slider bushing is felt. Then move it in and out, tapping the bushing lightly until the fork tube separates from the slider. The slider bushing will be forced out by the fork tube bushing.

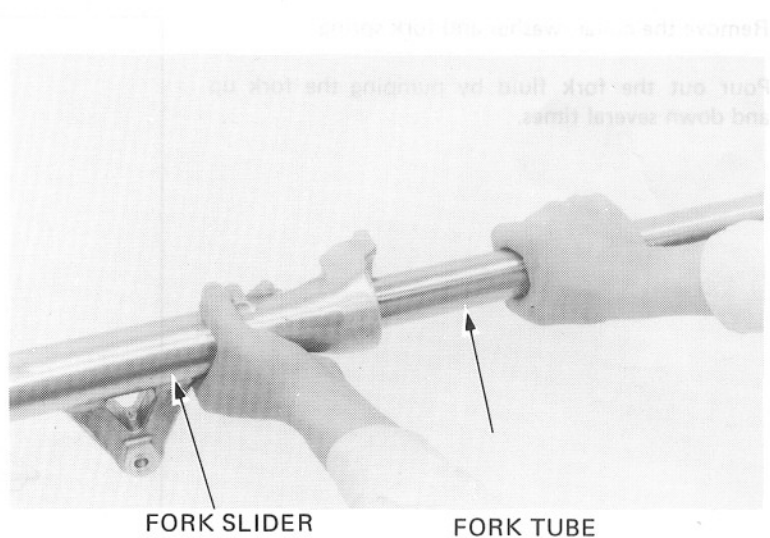

Remove the oil lock piece from inside the slider.

Remove the oil seal, back-up ring and slider bushing from the fork tube.

NOTE

Do not remove the fork tube bushing unless it is necessary to replace it with a new one.

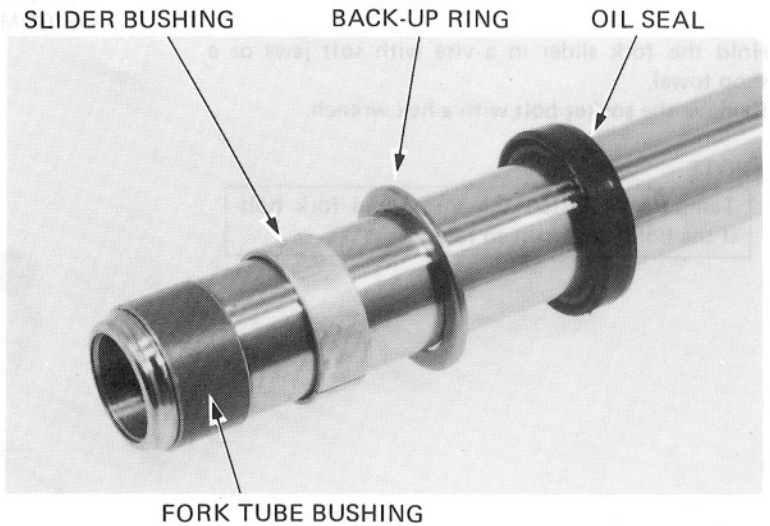



On the left fork, remove the circlip, oil lock valve spring, and spring seat from the piston. Remove the piston and rebound spring from the fork tube.

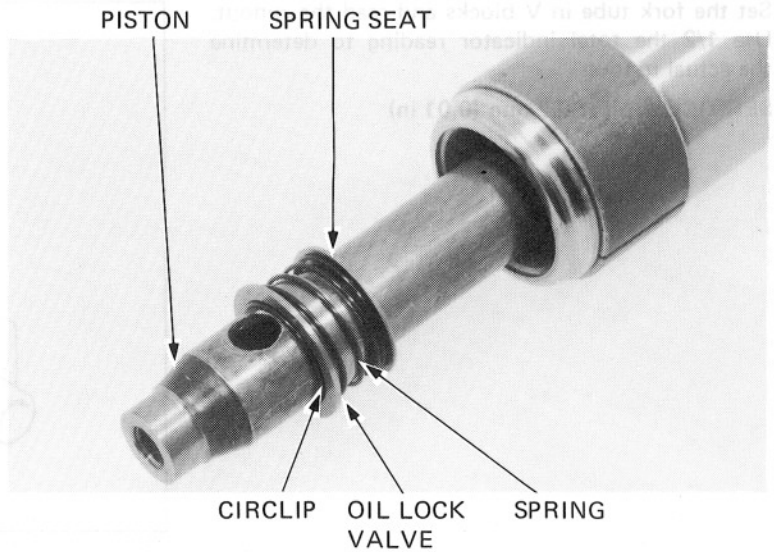

INSPECTION

Measure the fork spring free length.

SERVICE LIMIT: 471.3 mm (18.6 in)

Replace the spring if it is shorter than the service limit.

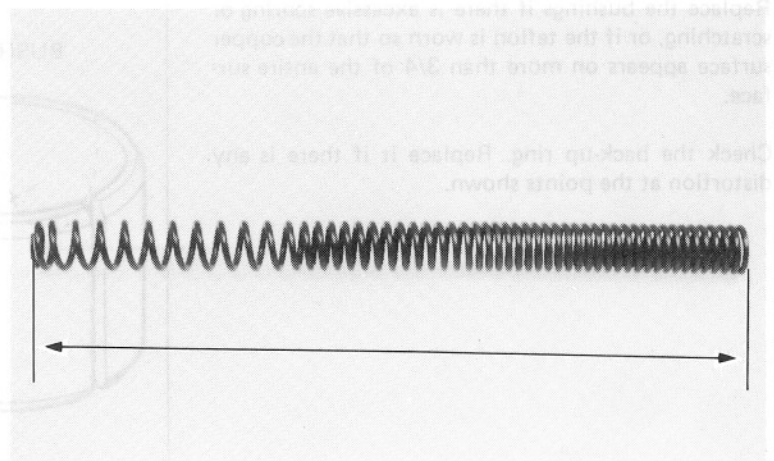

Check the fork tube, fork slider and piston for score marks, scratches, or excessive or abnormal wear. Replace any components which are worn or damaged.

Check the fork piston ring for wear or damage.

Check the rebound spring for fatigue or damage.

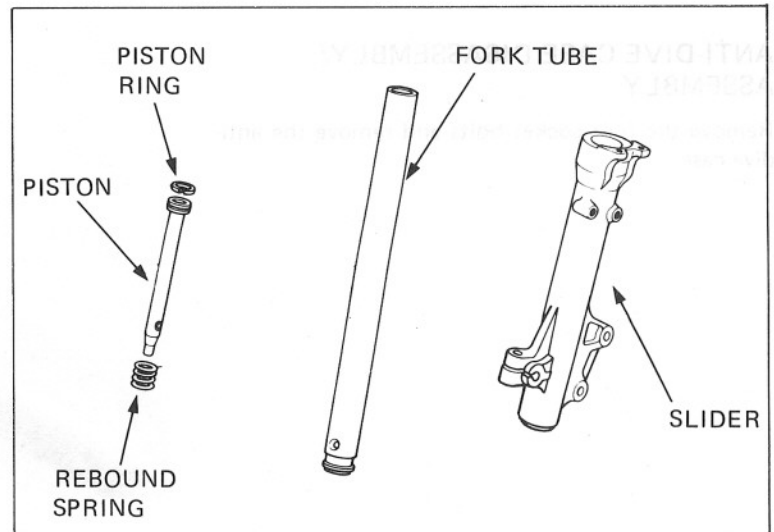



FRONT WHEEL/SUSPENSION

Set the fork tube in V blocks and read the runout. Use 1/2 the total indicator reading to determine the actual runout.

SERVICE LIMIT: 0.2 mm (0.01 in)

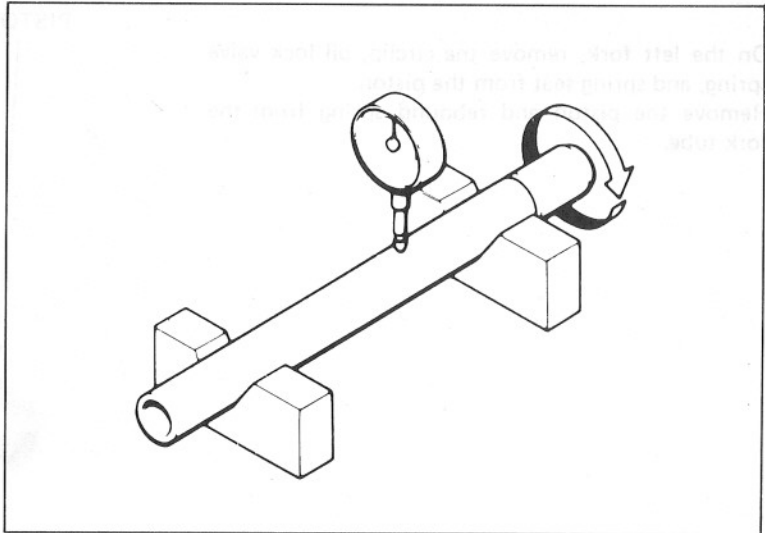

Visually inspect the slider and fork tube bushings. Replace the bushings if there is excessive scoring or scratching, or if the teflon is worn so that the copper surface appears on more than 3/4 of the entire surface.

Check the back-up ring. Replace it if there is any distortion at the points shown.

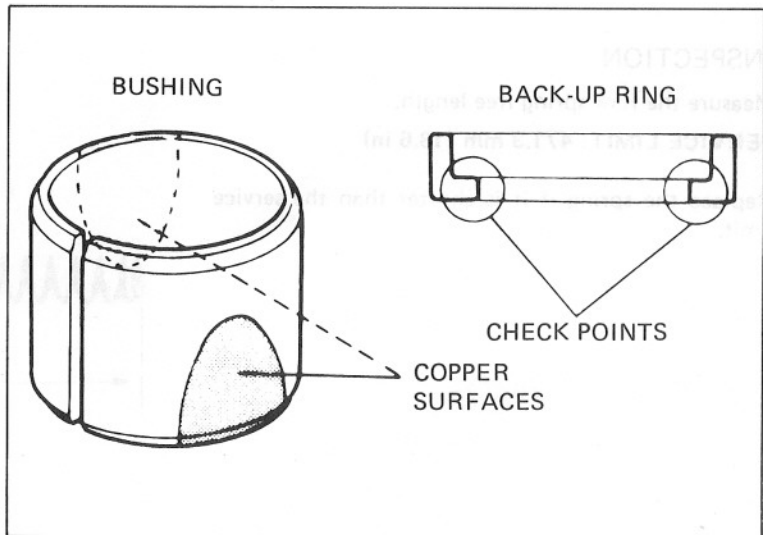

**ANTI-DIVE CASE DISASSEMBLY/
ASSEMBLY**

Remove the four socket bolts and remove the anti-dive case.

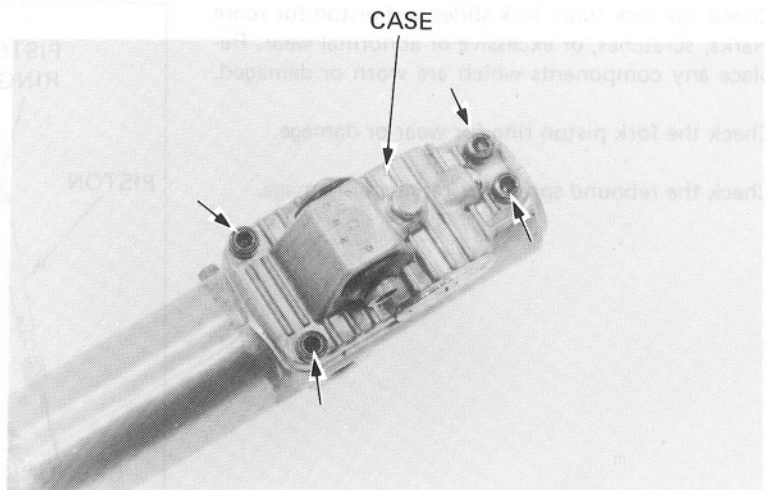



Remove the piston and spring.
Remove the boots, pivot bolt collar and stop rubber.

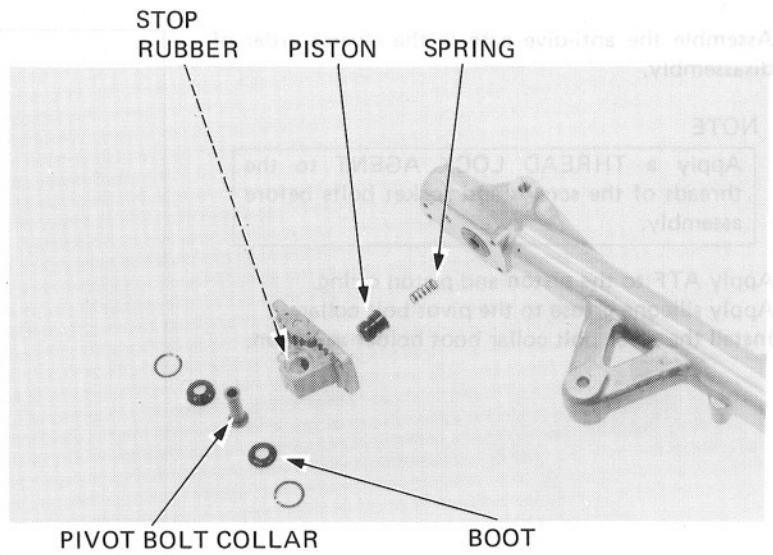

Check the spring and piston for wear or damage.

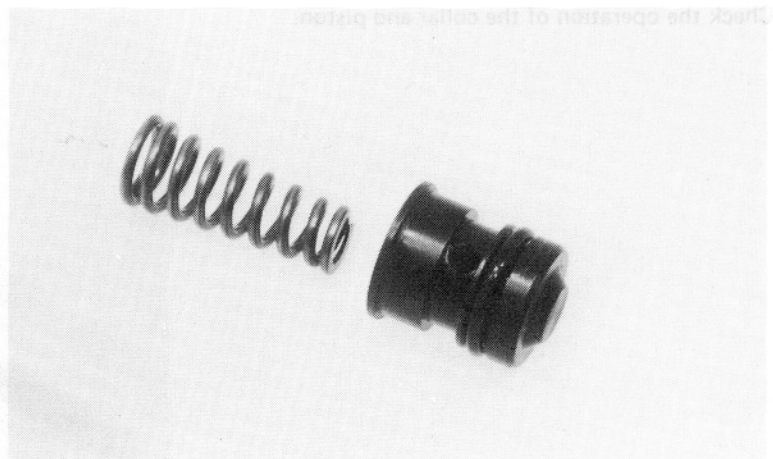

Remove the orifice setting plate screws, setting plate and orifice.
Check the orifice for clogging by applying compressed air. Also check the orifice for damage and replace if necessary.
Remove the check valve setting screw, valve spring and check ball.

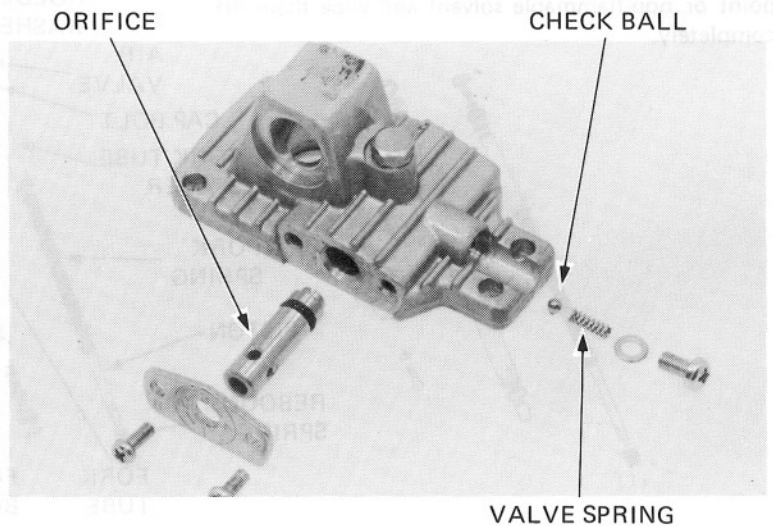



FRONT WHEEL/SUSPENSION

Assemble the anti-dive case in the reverse order of disassembly.

NOTE

Apply a **THREAD LOCK AGENT** to the threads of the screws and socket bolts before assembly.

Apply ATF to the piston and piston o-ring.
Apply silicone grease to the pivot bolt collar.
Install the pivot bolt collar boot holder as shown.

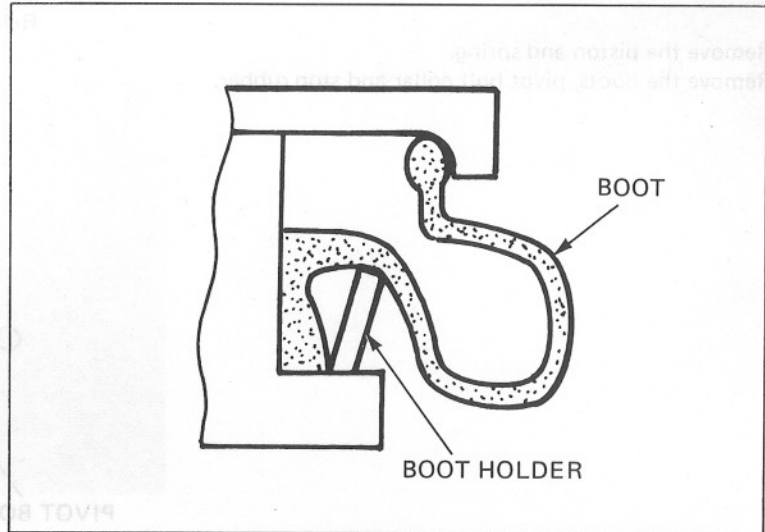

Check the operation of the collar and piston.

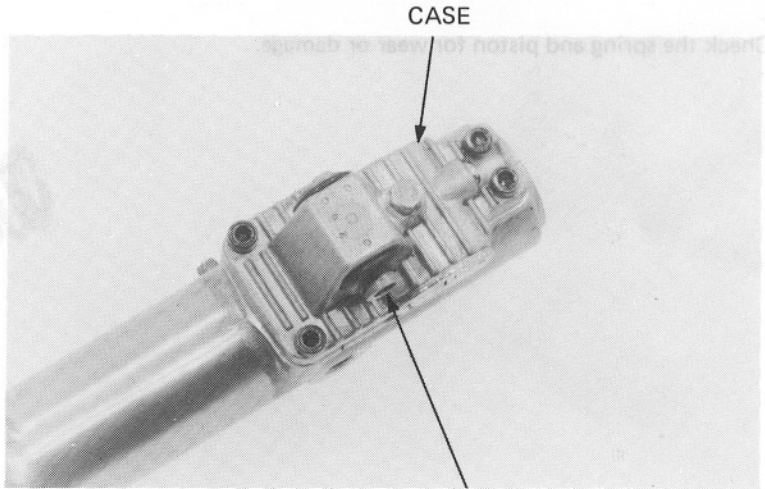

ASSEMBLY

Before assembly, wash all parts with a high flash point or non-flammable solvent and wipe them off completely.

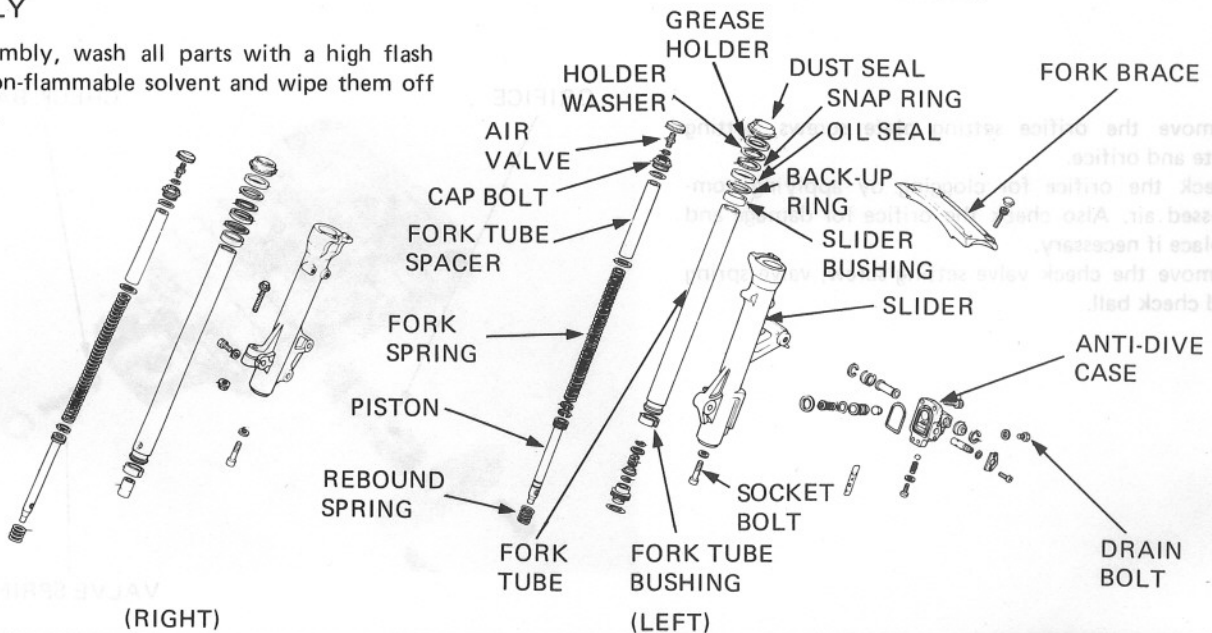



Insert the rebound spring and piston into the fork tube.

On the left fork, install the spring seat, valve spring, oil lock valve and circlip on the piston.

Place the oil lock piece on the end of the piston and insert the fork tube into the slider.

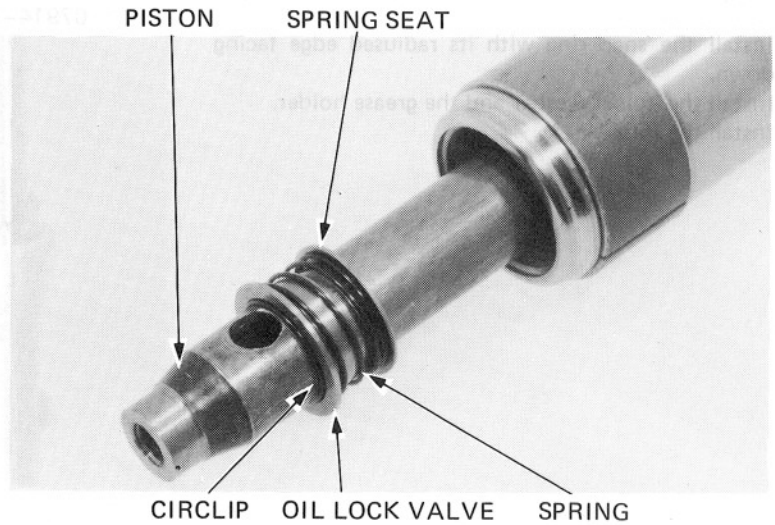

HEX WRENCH, 6 mm 07917-3230000
OR COMMERCIALY AVAILABLE

Place the fork slider in a vise with soft jaws or a shop towel.

Apply a locking agent to the socket bolt and thread it into the piston. Tighten with a 6 mm hex wrench.

TORQUE: 15-25 N·m (1.5-2.5 kg·m, 11-18 ft·lb)

NOTE

Temporarily install the fork spring and fork cap bolt to tighten the socket bolt.

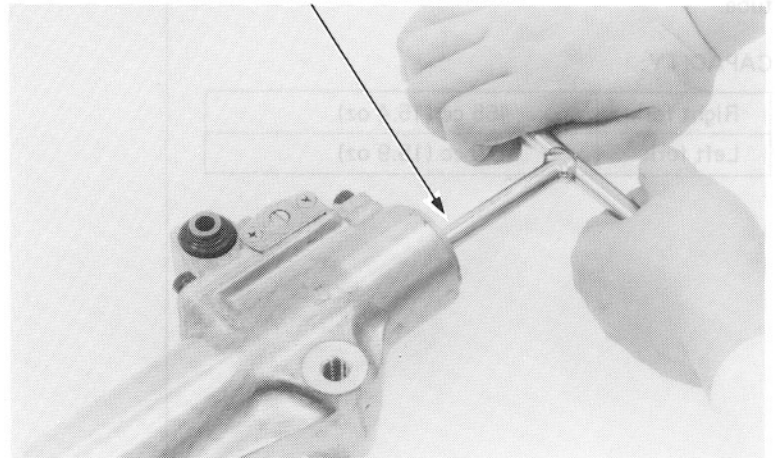

FORK SEAL DRIVER
07947-4630100

Place the slider bushing over the fork tube and rest it on the slider. Put the back-up ring and an old bushing or equivalent tool on top.

Drive the bushing into place with the seal driver and remove the old bushing or equivalent tool.

Coat a new oil seal with ATF and install it with the seal markings facing up.

Drive the seal in with the seal driver.

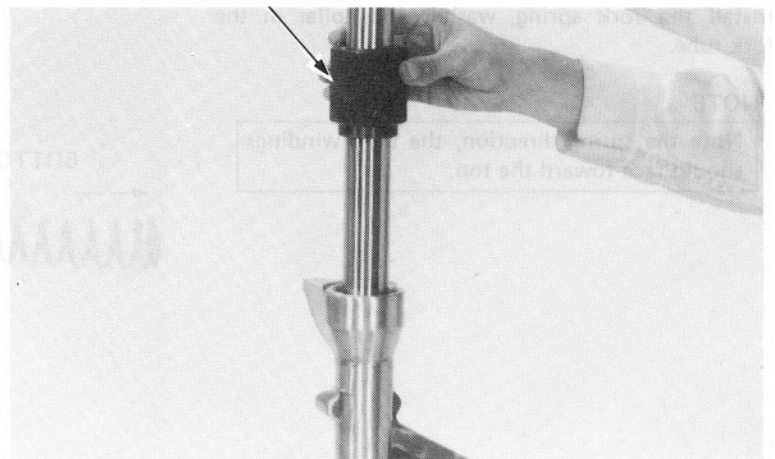



FRONT WHEEL/SUSPENSION

SNAP RING PLIERS
07914-3230001

Install the snap ring with its radiused edge facing down.
Install the holder washer and the grease holder.
Install the dust seal.

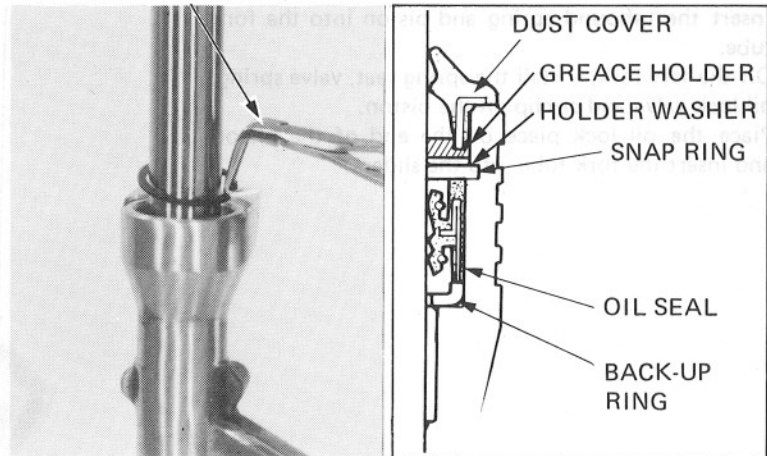

Pour the specified amount of ATF into the fork tube.

CAPACITY:

Right fork	455 cc (15.4 oz)
Left fork	470 cc (15.9 oz)

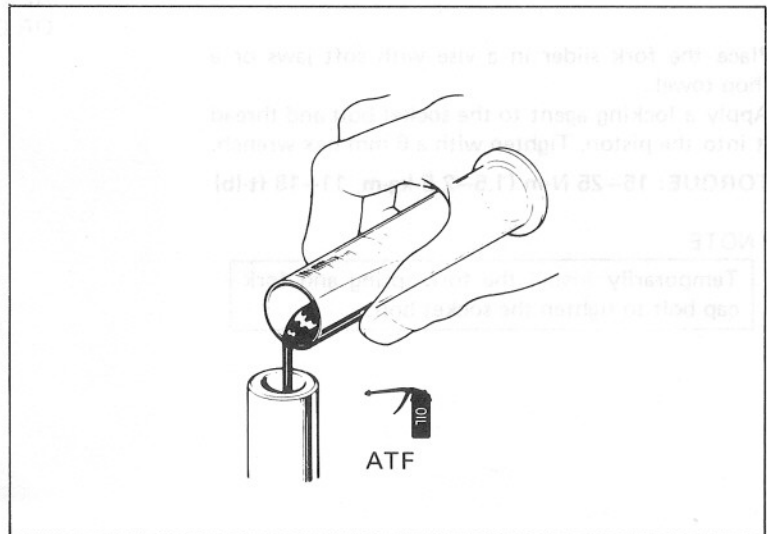

Install the fork spring, washer and collar in the fork tube.

NOTE

Note the spring direction, the tight windings should face toward the top.

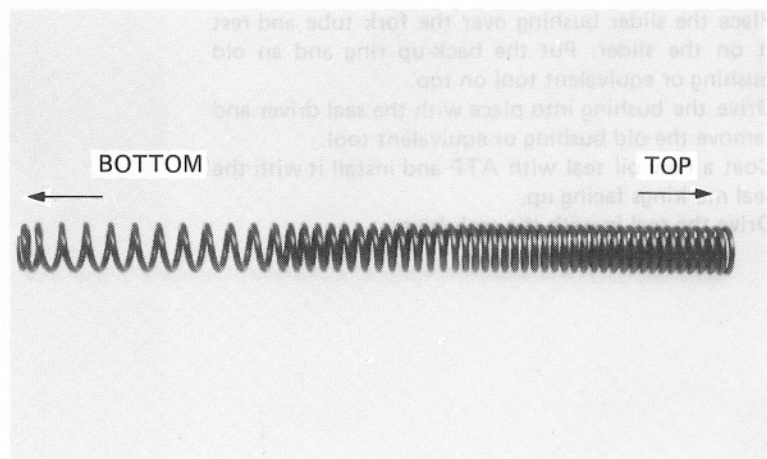



Install and torque the fork tube cap.

TORQUE: 15–30 N·m (1.5–3.0 kg-m, 11–22 ft-lb)

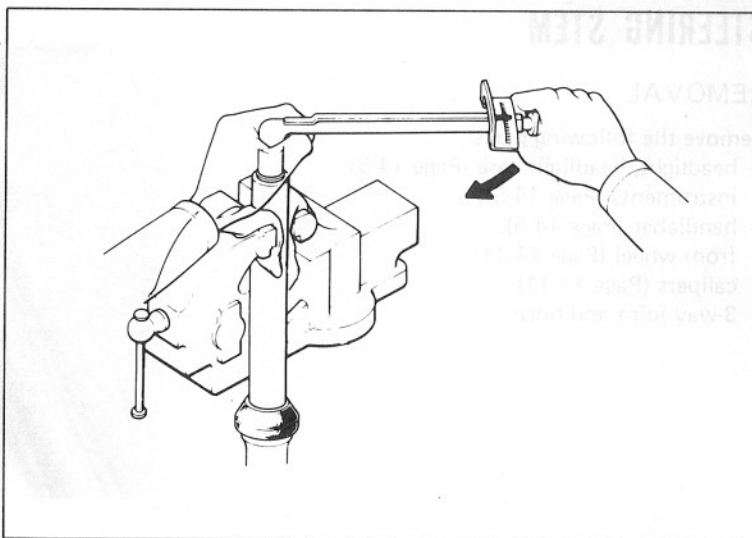

INSTALLATION

Install the left front fork with the groove on the fork flush with the top of the fork bridge.
Tighten the bottom pinch bolt.

TORQUE: 45–55 N·m (4.5–5.5 kg-m, 33–40 ft-lb)

Tighten the top pinch bolt.

TORQUE: 9–13 N·m (0.9–1.3 kg-m, 7–9 ft-lb)

Install the right front fork loosely.
Install the fork brace hex bolts loosely.
Tighten the bottom and top pinch bolts on the right fork to the specified torque values above.
Install the front fender and brake caliper.
Install the front wheel (Page 14-15).

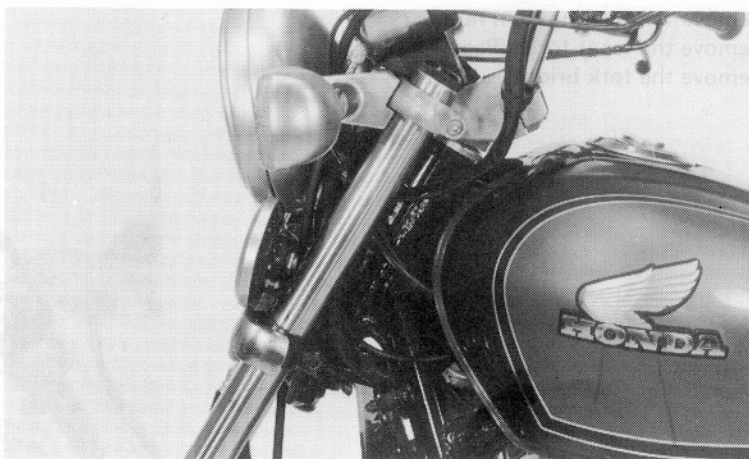

Tighten the fork brace bolts to the specified torque.

TORQUE: 18–28 N·m (1.8–2.8 kg-m, 13–20 ft-lb)

Fill the fork tubes with air to 40–100 kPa (0.4–1.0 kg/cm², 6–14 psi).

CAUTION

- Use only a hand operated air pump to fill to fork tubes. Do not use compressed air.
- Maximum pressure is 300 kPa (3 kg/cm², 43 psi). Do not exceed this or fork tube component damage may occur.

With the front brake applied, pump the front forks up and down several times. Place the motorcycle on its center stand. Check the air pressure and adjust if necessary.





FRONT WHEEL/SUSPENSION

STEERING STEM

REMOVAL

Remove the following parts:

- headlight, headlight case (Page 14-3).
- instruments (Page 14-5).
- handlebar (Page 14-6).
- front wheel (Page 14-11).
- calipers (Page 17-11).
- 3-way joint and horn.

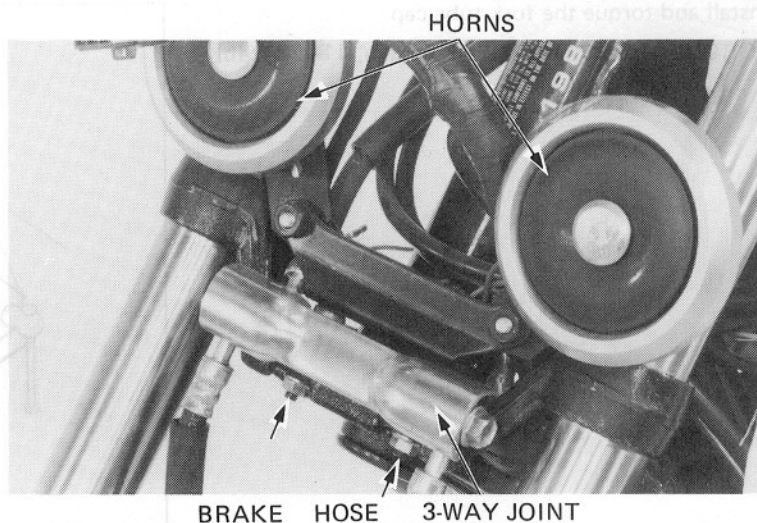

LOCK NUT WRENCH, 30 x 32 mm
(COMMERCIALLY AVAILABLE)

EXTENSION BAR
(COMMERCIALLY AVAILABLE)

Remove the steering stem nut.
Remove the front forks (Page 14-16).
Remove the fork bridge.

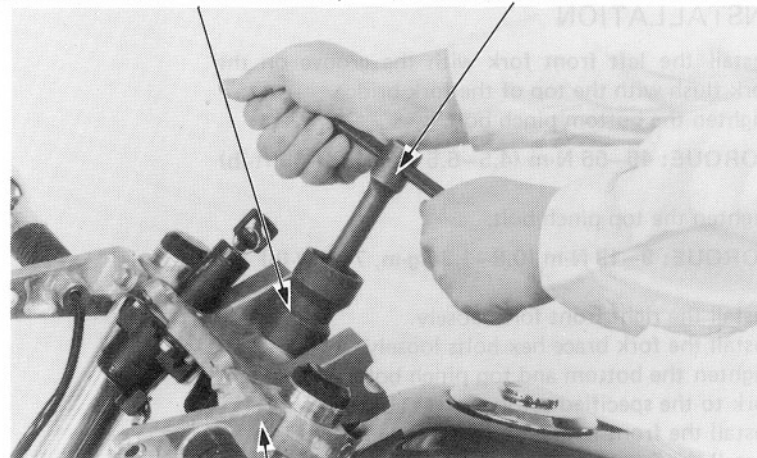

FORK BRIDGE

Bend the lock washer tab down and remove the lock nut and lock washer.

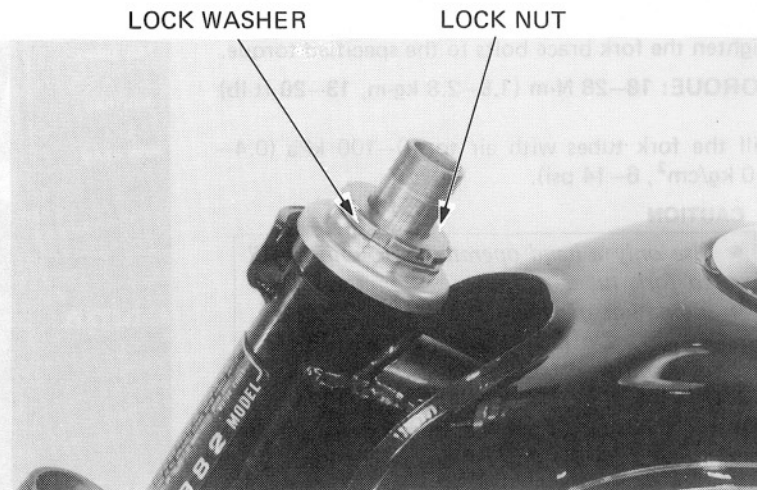

LOCK WASHER

LOCK NUT



Remove the bearing adjustment nut and the steering stem.



STEERING STEM SOCKET
07916-3710100

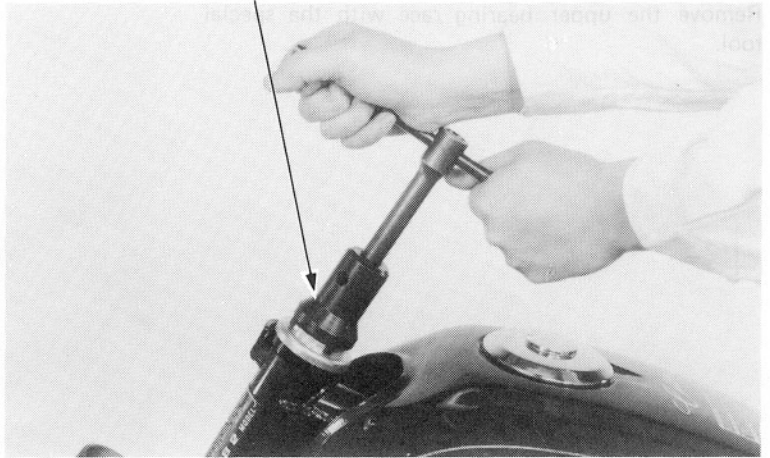

Check the steering stem bearing for damage or wear.

NOTE

Replace the bearing and bearing race as a set.

Remove the bearing from the steering stem.

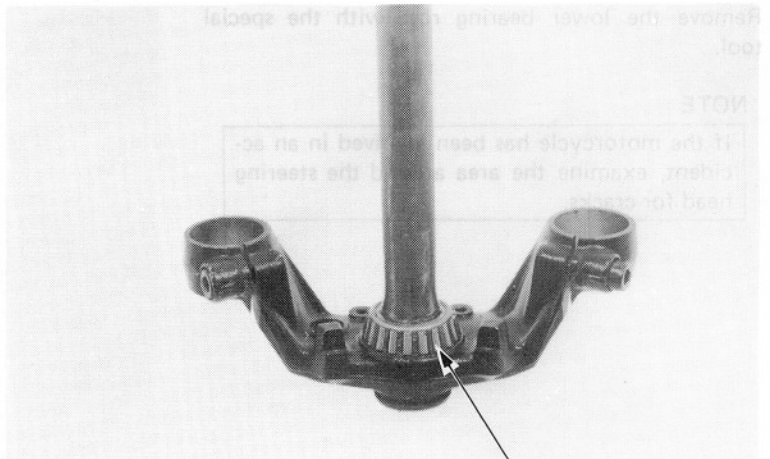

BEARING

Install a dust seal onto the steering stem and press the lower bearing inner race over the stem with the special tool.



STEERING STEM DRIVER
07946-MB00000

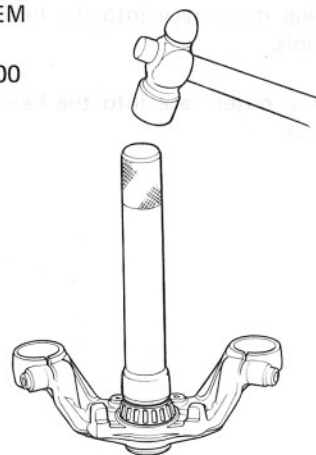



FRONT WHEEL/SUSPENSION

Remove the upper bearing race with the special tool.

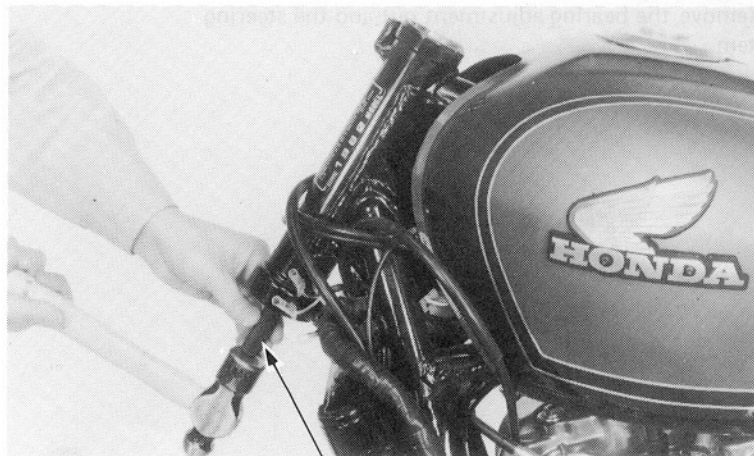

BEARING RACE REMOVER
07954-4250002

Remove the lower bearing race with the special tool.

NOTE

If the motorcycle has been involved in an accident, examine the area around the steering head for cracks.

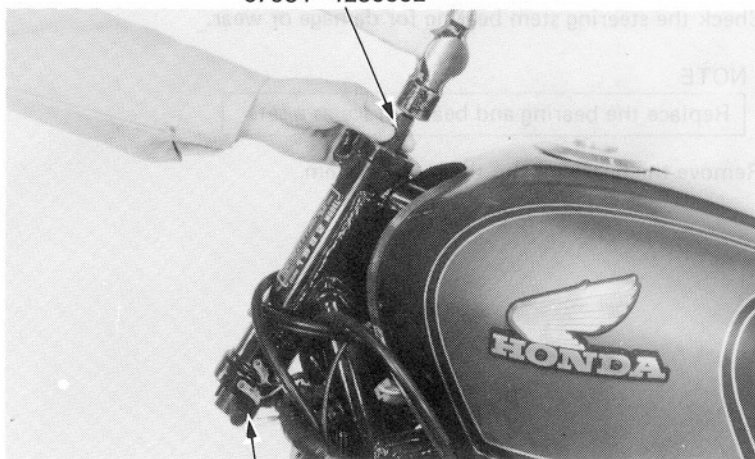

BEARING RACE REMOVER
07954-4250002

BEARING RACE REMOVER
07946-3710500

Drive the upper bearing outer race into the head pipe with the special tools.

Drive the lower bearing outer race into the head pipe with the special tool.

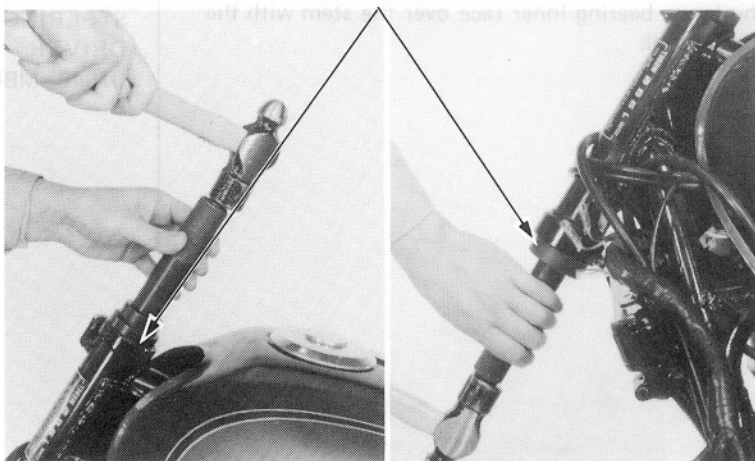

BEARING DRIVER ATTACHMENT
07946-3710701



INSTALLATION

Pack the bearing cavities with bearing grease.
Insert the steering stem into the steering head pipe and install the bearing retainer and upper bearing inner race.

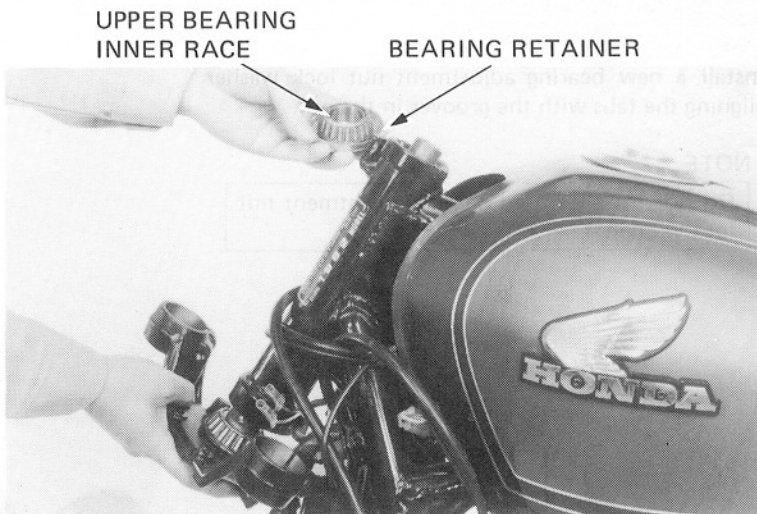

Install and tighten the adjustment nut.
TORQUE: 14–16 N·m (1.4–1.6 kg·m, 10–12 ft·lb)

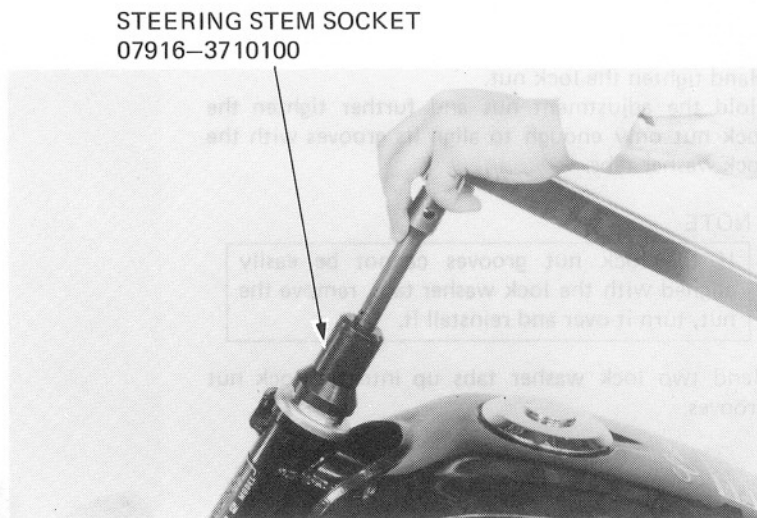

Turn the steering stem lock-to-lock 5 times to seat the bearing and tighten the adjusting nut again. Repeat the bearing tightening and steering stem turning sequence twice.
If the nut does not need tightening after turning the steering stem the first or second time, remove the nut and inspect it and the steering stem threads for dirt or burrs.

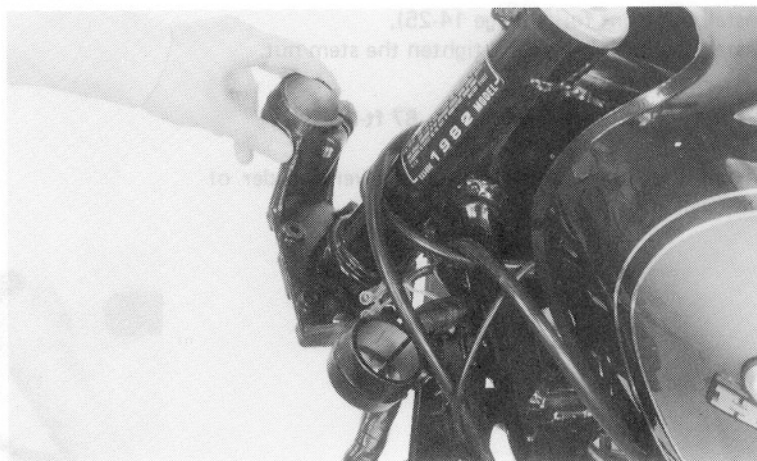



FRONT WHEEL/SUSPENSION

Install a new bearing adjustment nut lock washer aligning the tabs with the grooves in the nut.

NOTE

Do not install a used bearing adjustment nut lock washer.

LOCK WASHER

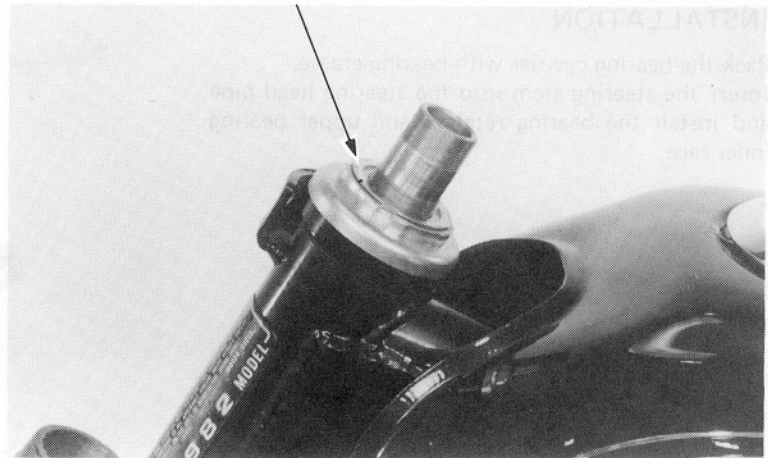

Hand tighten the lock nut.
Hold the adjustment nut and further tighten the lock nut only enough to align its grooves with the lock washer tabs.

NOTE

If the lock nut grooves cannot be easily aligned with the lock washer tabs, remove the nut, turn it over and reinstall it.

Bend two lock washer tabs up into the lock nut grooves.

LOCK WASHER

LOCK NUT

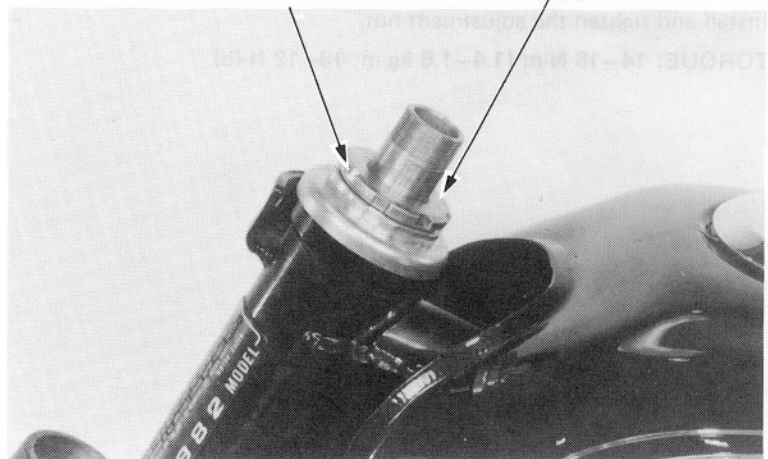

Install the front forks (Page 14-25).
Install the fork bridge and tighten the stem nut.

TORQUE: 80–120 N·m
(8.0–12.0 kg·m, 58–87 ft·lb)

Install the removed parts in the reverse order of removal.

LOCK NUT WRENCH, 30 x 32 mm
(COMMERCIALLY AVAILABLE)

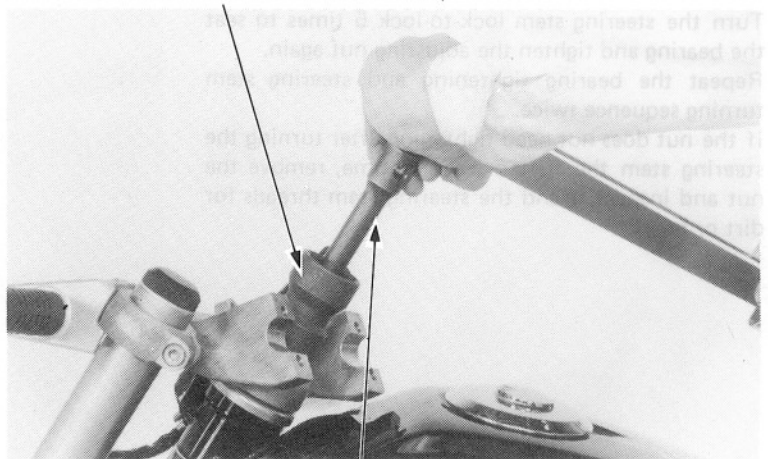

EXTENSION BAR (COMMERCIALLY AVAILABLE)