



11. CRANKCASE

SERVICE INFORMATION	11-1
CRANKCASE DISASSEMBLY	11-2
CRANKCASE ASSEMBLY	11-3

SERVICE INFORMATION

GENERAL

- To repair the crankshaft, connecting rod, primary shaft and the transmission including the shift fork and drum, it is necessary to separate the crankcase halves.
- The following parts must be removed before disassembling the crankcase.

- Oil pan See section 2
- Oil pump See section 2
- Cylinder head See section 6
- Cylinder/pistons See section 7
- Clutch and starter clutch See section 8
- Gearshift linkage See section 9
- Subtransmission See section 10
- Alternator See section 18
- Starter motor See section 20

TORQUE VALUES

8 mm bolt (Crankshaft)	21-25 N·m (2.1-2.5 kg-m, 15-18 ft-lb)
8 mm bolt (Crankcase)	21-25 N·m (2.1-2.5 kg-m, 15-18 ft-lb)
6 mm bolt	10-14 N·m (1.0-1.4 kg-m, 7-10 ft-lb)
10 mm bolt	45-50 N·m (4.5-5.0 kg-m, 33-36 ft-lb)

CRANKCASE DISASSEMBLY

Remove the upper crankcase bolts.

Turn the engine upside-down and remove the lower crankcase bolts.

NOTE

Remove the bolts in two or more steps and in a crisscross pattern to prevent warpage.

Separate the crankcase.

CAUTION

Do not pry between the upper and lower cases.

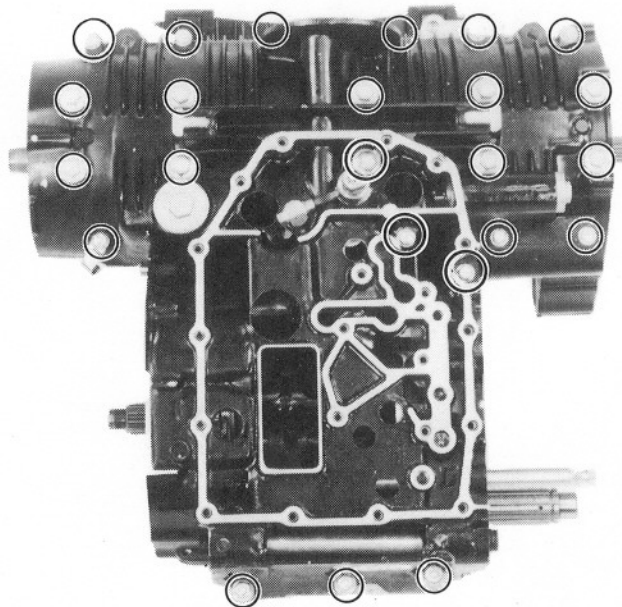
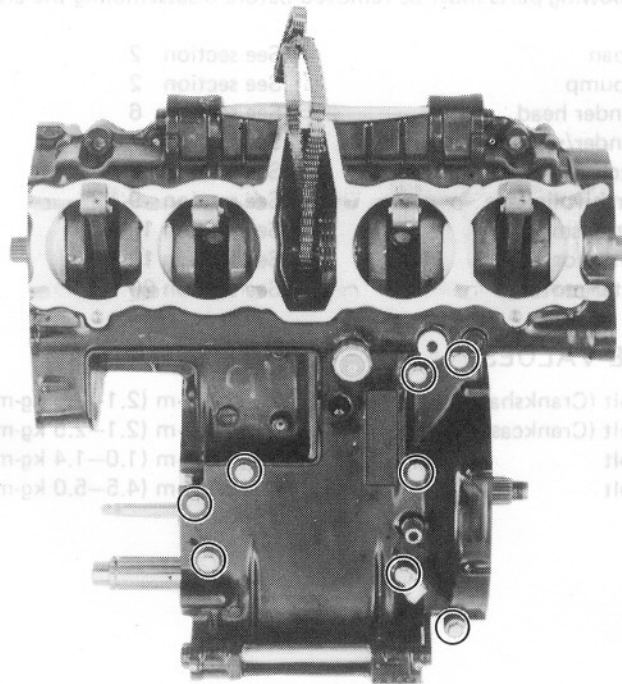



CRANKCASE ASSEMBLY

NOTE

When the gearshift linkage is installed in the lower crankcase, shift the transmission into first for easy crankcase assembly.

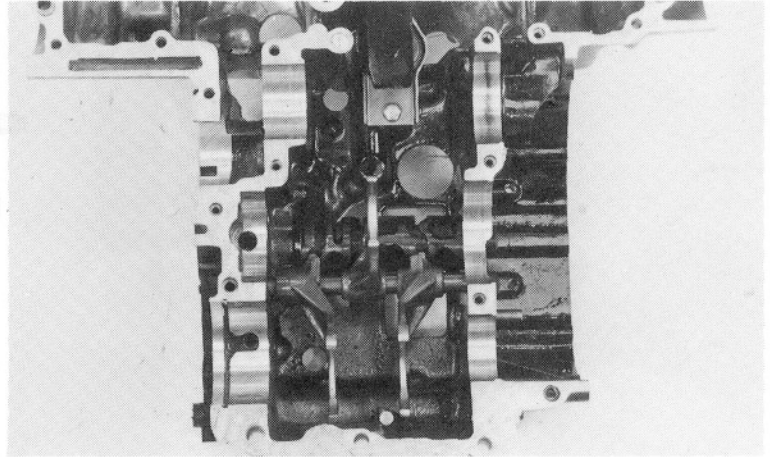

Slide the C4 gear into the C1 gear.
Make sure that the other gears are not engaged.

Apply molybdenum disulfide grease to the groove of the M3 gear and C4, C5 gears.

Apply molybdenum disulfide grease to the crankshaft main bearings.

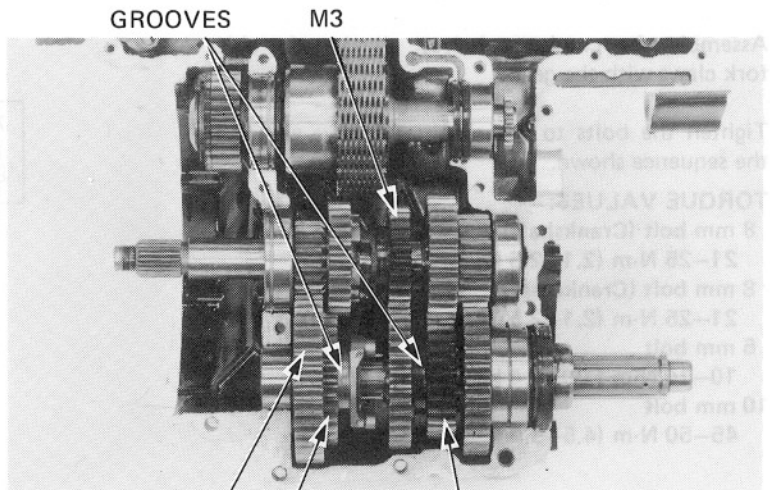

LOWER CRANKCASE

Clean the crankcase mating surfaces.
Apply liquid sealant to the mating surface of the lower and upper crankcase.

CAUTION

Do not apply sealant to the area near the main bearings.

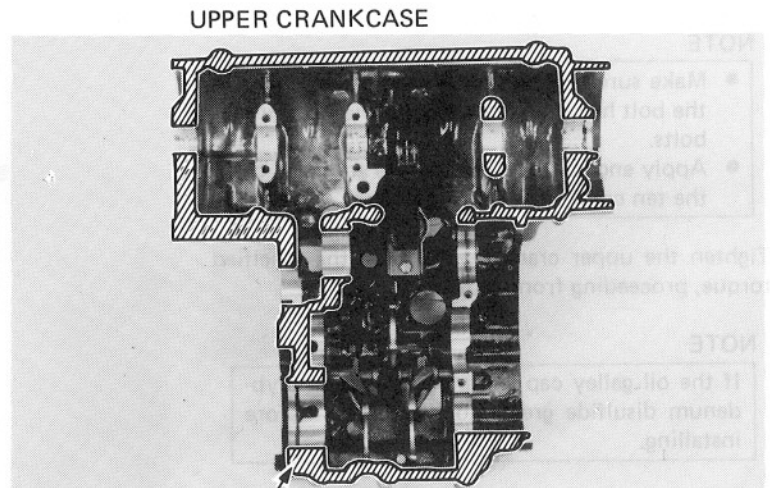

SEALANT

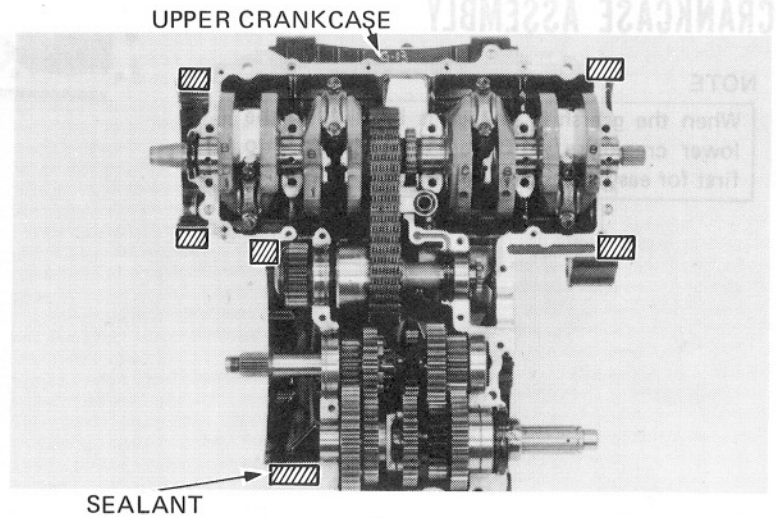

Assemble the crankcase halves, aligning the shift fork claws with the gears.

Tighten the bolts to the specified torque values in the sequence shown.

TORQUE VALUES:

- 8 mm bolt (Crankshaft)
21–25 N·m (2.1–2.5 kg-m, 15–18 ft-lb)
- 8 mm bolt (Crankcase)
21–25 N·m (2.1–2.5 kg-m, 15–18 ft-lb)
- 6 mm bolt
10–14 N·m (1.0–1.4 kg-m, 7–10 ft-lb)
- 10 mm bolt
45–50 N·m (4.5–5.0 kg-m, 33–36 ft-lb)

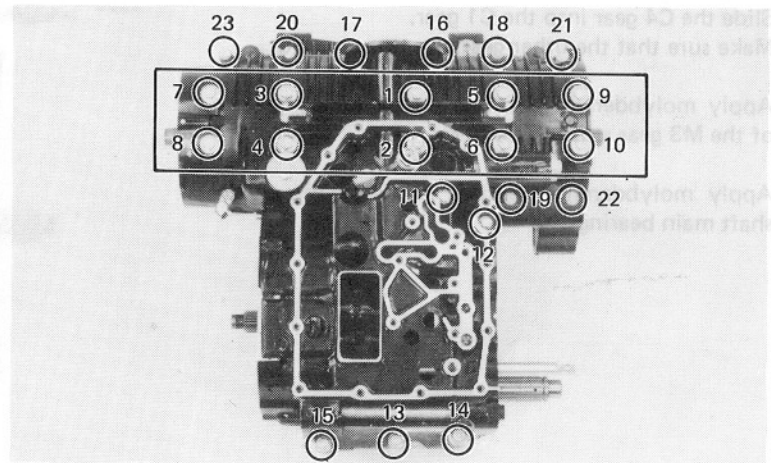

NOTE

- Make sure that the plain washers are under the bolt heads of the ten crankshaft bearing bolts.
- Apply engine oil to the threads and head of the ten crankshaft holding bolts.

Tighten the upper crankcase bolts to the specified torque, proceeding front to rear.

NOTE

If the oil galley cap is removed, apply molybdenum disulfide grease to the threads before installing.

